



## Crystal Can Welded • 4PDT Magnetic Latching Dry Circuit to 10 Amps

- **PATENTED CONTACT STRUCTURE?** for the most reliable 10-amp magnetic latching relay in the industry
- **AVAILABLE WITH BIFILAR WOUND COIL?** for inductive spike suppression
- **SPACE ENVIRONMENT VERSIONS?** can be manufactured under extreme high-reliability controls

## SPECIFICATIONS

### GENERAL

**Contact Arrangement** .....4PDT (4 Form C)  
Magnetic Latching

**Weight** .....3.0 oz approx.  
Designed to meet the requirements of MIL-PRF-39016.

### PERFORMANCE

#### Contact Rating (Note 1)

Resistive .....10 Amps @ 28 VDC or 115V 400 Hz  
(Case Ungrounded)

Inductive .....3.5 Amps @ 28 VDC

**Life** .....100,000 operations minimum  
@ rated load, 125°C

#### Latch/Reset Power:

BR23AX .....500 mv approx.

BR23BX .....250 mv approx.

**Latch/Reset Time** .....10 ms max, excluding  
bounce time at nominal coil voltage

**Contact Bounce Time** .....2 ms max  
@ 10 Amps 28 VDC

#### Contact Voltage Drop:

Before Life .....100 mv max @ rated current  
6 or 28 VDC

After Life .....200 mv max @ rated current  
6 or 28 VDC

### ENVIRONMENTAL

**Temperature Range** .....-65°C to +125°C

**Vibration** (Note 2) .....0.4" DA 10 - 38 Hz,  
20 G's 38 - 2,000 Hz

**Shock (Operating)** (Note 2) .....50 G's 11 ms

### ELECTRICAL CHARACTERISTICS

**Duty Cycle** .....Continuous

**Insulation Resistance**  
10,000 megohms @ 500V 25°C  
1,000 megohms @ 500V 125°C

#### Dielectric Strength:

Sea Level:  
Between Coils (BR23AX) .....500 VRMS  
Contact to Case .....1,250 VRMS  
Contact to Coil .....1,250 VRMS  
Coil to Case .....1,000 VRMS  
Across Open Contacts .....1,250 VRMS  
70,000 Feet  
All points .....500 VRMS

### Notes

1. For case grounded loads and other ratings, consult the factory.
2. For applications requiring other shock and vibration levels, consult the factory.
3. For other ratings consult the factory.
4. Relay contacts which have switched high level currents are no longer suitable for switching low level loads.
5. Contacts were placed in the position shown by placing voltage with the polarity shown on the indicated coil (reset). To switch contacts, a voltage of indicated polarity must be applied to the other coil (Latch).
6. Contacts were placed in position shown by placing voltage with the polarity indicated on the coil. To switch contacts a voltage of the reverse polarity must be applied to the coil.

## COIL DATA

PART NUMBER		BR23AX-( )-V1	BR23AX-( )-V2	BR23AX-( )-V3	BR23AX-( )-V4	BR23AX-( )-V5
MODEL BR23AX — 10 Amps (Each Coil, 500 MW)						
MODEL BR23BX — 10 Amps (Single Coil, 250 MW)						
NOMINAL COIL VOLTAGE		6 VDC	12 VDC	26 VDC	48 VDC	115 VDC
MAXIMUM COIL VOLTAGE		7.3 VDC	14.8 VDC	32 VDC	59 VDC	127 VDC
LATCH/RESET VOLTAGE (MAX at +125°C)		4.4 VDC	8.4 VDC	18 VDC	34.5 VDC	79 VDC
LATCH/RESET VOLTAGE (MAX)		3 VDC	6 VDC	13 VDC	24 VDC	57.5 VDC
COIL RESISTANCE ± 10% at 25°C	BR23AX	15 OHMS	60 OHMS	300 OHMS	1100 OHMS	5,000 OHMS
	BR23BX	37 OHMS	125 OHMS	600 OHMS	2200 OHMS	10,000 OHMS

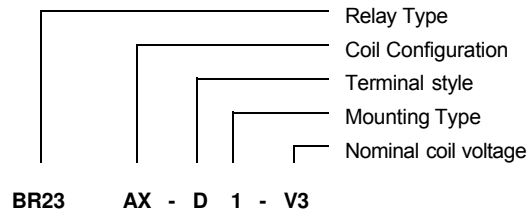

## SCHEMATIC TERMINAL VIEW

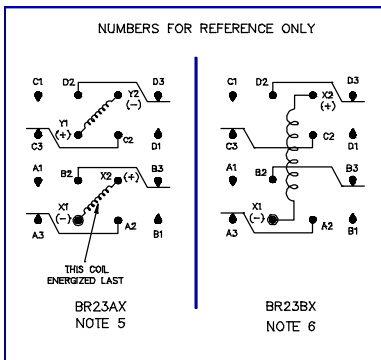

## MOUNTING CODES

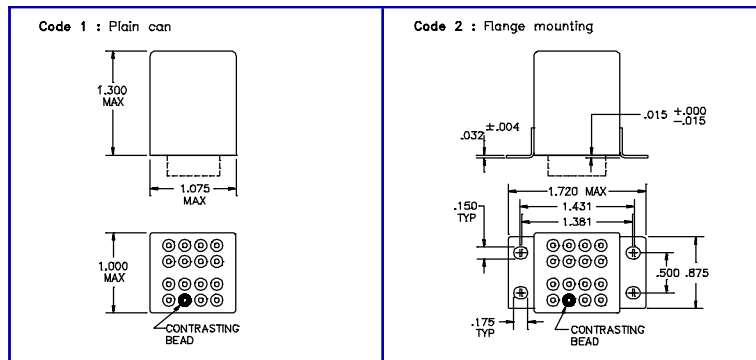

## TERMINAL STYLES

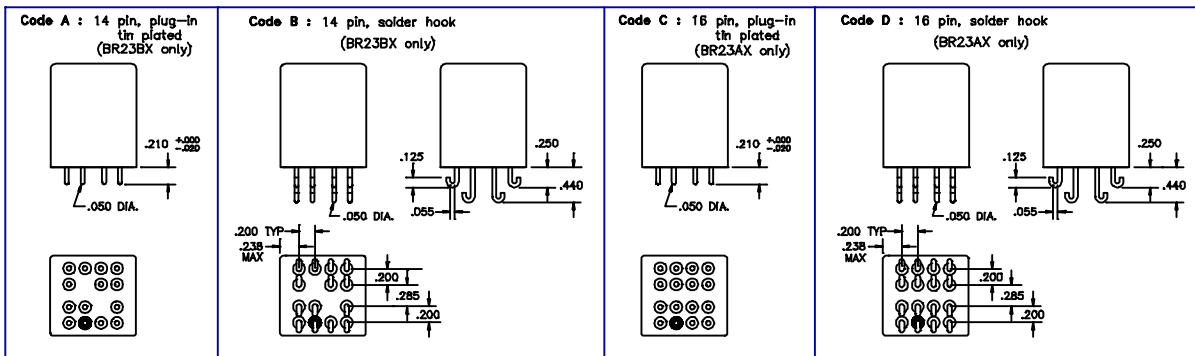

## GENERAL NOTES

- Unless otherwise specified, all tests made at nominal coil voltages, @ 25°C.
- For special coil variations, switching configurations, terminals styles and mounting types, consult the factory.
- Unless otherwise specified, tolerances on decimal dimensions are ± .010".
- Specifications contained herein are subject to change without notice.



**Microsemi Corporate Headquarters**  
One Enterprise, Aliso Viejo,  
CA 92656 USA

**Within the USA:** +1 (800) 713-4113  
**Outside the USA:** +1 (949) 380-6100  
**Sales:** +1 (949) 380-6136  
**Fax:** +1 (949) 215-4996

**E-mail:** [sales.support@microsemi.com](mailto:sales.support@microsemi.com)

© 2015 Microsemi Corporation. All rights reserved. Microsemi and the Microsemi logo are trademarks of Microsemi Corporation. All other trademarks and service marks are the property of their respective owners.

Microsemi Corporation (Nasdaq: MSCC) offers a comprehensive portfolio of semiconductor and system solutions for communications, defense & security, aerospace and industrial markets. Products include high-performance and radiation-hardened analog mixed-signal integrated circuits, FPGAs, SoCs and ASICs; power management products; timing and synchronization devices and precise time solutions, setting the world's standard for time; voice processing devices; RF solutions; discrete components; security technologies and scalable anti-tamper products; Power-over-Ethernet ICs and midspans; as well as custom design capabilities and services. Microsemi is headquartered in Aliso Viejo, Calif., and has approximately 3,400 employees globally. Learn more at [www.microsemi.com](http://www.microsemi.com).

Microsemi makes no warranty, representation, or guarantee regarding the information contained herein or the suitability of its products and services for any particular purpose, nor does Microsemi assume any liability whatsoever arising out of the application or use of any product or circuit. The products sold hereunder and any other products sold by Microsemi have been subject to limited testing and should not be used in conjunction with mission-critical equipment or applications. Any performance specifications are believed to be reliable but are not verified, and Buyer must conduct and complete all performance and other testing of the products, alone and together with, or installed in, any end-products. Buyer shall not rely on any data and performance specifications or parameters provided by Microsemi. It is the Buyer's responsibility to independently determine suitability of any products and to test and verify the same. The information provided by Microsemi hereunder is provided "as is, where is" and with all faults, and the entire risk associated with such information is entirely with the Buyer. Microsemi does not grant, explicitly or implicitly, to any party any patent rights, licenses, or any other IP rights, whether with regard to such information itself or anything described by such information. Information provided in this document is proprietary to Microsemi, and Microsemi reserves the right to make any changes to the information in this document or to any products and services at any time without notice.