



ST16SF41

Smartcard MCU

With 1344 Bytes EEPROM

DATA BRIEF

- 8 BIT ARCHITECTURE CPU
- 16 K Bytes of USER ROM, SECTOR COMBINATIVE
- 1.5 K Byte of SYSTEM ROM
- 384 Bytes of RAM
- 1344 Bytes of EEPROM, SECTOR COMBINATIVE
 - Highly reliable CMOS EEPROM technology
 - 10 year data retention
 - 300,000 Erase/Write cycle endurance
 - Protected One Time Programmable block (32 or 64 bytes)
 - 1 to bytes block either Erase or Write in single cycle programming
- EXTENDED VOLTAGE OPERATION
 - V_{CC} Range: 2.7V to 5.5V
- SERIAL ACCESS, ISO 7816-3 COMPATIBLE
- POWER SAVING STANDBY MODE
- UP TO 5 MHz INTERNAL OPERATING FREQUENCY
- VERY HIGH SECURITY FEATURES INCLUDING EEPROM FLASH ERASE
- CONTACT ASSIGNMENT COMPATIBLE ISO 7816-2
- ESD PROTECTION GREATER THAN 5000V
- MEETS GSM 11.11 AND 11.12 SPECIFICATIONS
- 2 OPERATING CONFIGURATIONS
 - ISSUER
 - USER
- UNIQUE SERIAL NUMBER ON EACH DIE

Figure 1. Delivery Form

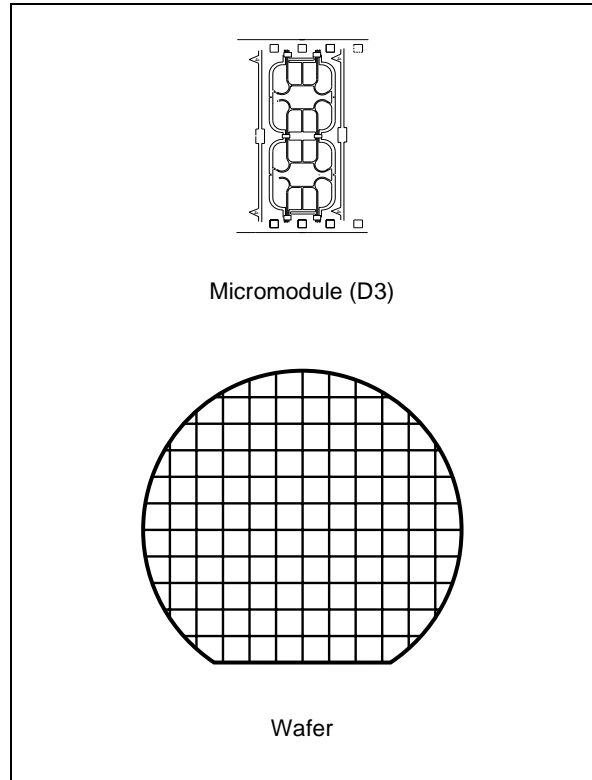

ST16SF41

DESCRIPTION

The ST16SF41, a member of the standard ST16 device family, is a serial access microcontroller especially designed for high volume and cost competitive Smartcard applications where firmware security algorithm must be implemented.

The ST16SF41 is based on 8 bit CPU core and includes on chip memories: 384 Bytes of RAM, 16 K Bytes of USER ROM, 1.5 K Byte of SYSTEM ROM, and 1344 Bytes of EEPROM.

Both ROM and EEPROM memories can be configured into two sectors. Access rules from any memory section or sector to any other are set-up by the User's defined Memory Access Control Matrix (MACM).

Reliability data related to the ST16SF41 product manufactured using STMicroelectronics advanced CMOS EEPROM technology confirm data retention up to 10 years and endurance up to 300,000 Erase/Write cycles.

As all other ST16 family members, the ST16SF41 is fully compatible with the ISO standards for Smartcard applications.

Software development (ROM code, options) can be completed by the ST16-19HDSE development system.

The ST16SF41 can be delivered either in unsawn or sawn wafers, 180 or 275 micron thickness as well as in micromodule package.

Figure 2. Block Diagram

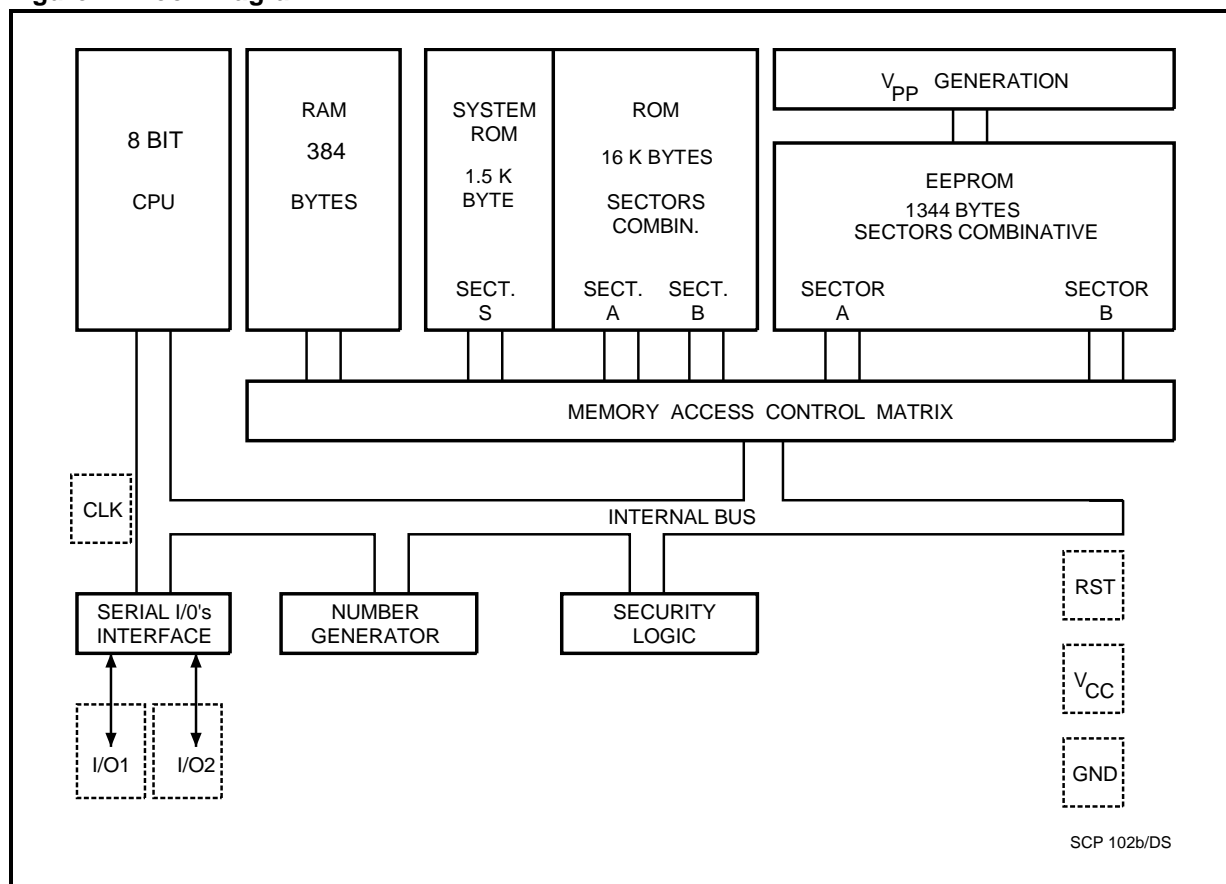

Information furnished is believed to be accurate and reliable. However, STMicroelectronics assumes no responsibility for the consequences of use of such information nor for any infringement of patents or other rights of third parties which may result from its use. No license is granted by implication or otherwise under any patent or patent rights of STMicroelectronics. Specifications mentioned in this publication are subject to change without notice. This publication supersedes and replaces all information previously supplied. STMicroelectronics products are not authorized for use as critical components in life support devices or systems without express written approval of STMicroelectronics.

The ST logo is a registered trademark of STMicroelectronics.
All other names are the property of their respective owners.

© 2000 STMicroelectronics - All rights reserved
BULL CP8 Patents

STMicroelectronics GROUP OF COMPANIES
Australia - Belgium - Brazil - Canada - China - Czech Republic - Finland - France - Germany -
Hong Kong - India - Israel - Italy - Japan - Malaysia - Malta - Morocco - Singapore -
Spain - Sweden - Switzerland - United Kingdom - United States
www.st.com