

SAW Filter 1590.1550MHz
Part No: MP06037

Model: TA1500A
Rev No: 2

A. MAXIMUM RATING:

Electrostatic Sensitive Device (ESD)

1. Input Power Level: 13dBm
2. DC Voltage: 3V
3. Operating Temperature: -20°C to +70°C
4. Storage Temperature: -40°C to +85°C

B. ELECTRICAL CHARACTERISTICS:

1. Terminating source impedance (single - ended): $Z_S = 50\Omega$
2. Terminating load impedance (single-ended): $Z_L = 50\Omega$

Item	Unit	Min.	Typ.	Max.	Note
Center Frequency Fc	MHz	-	1590.155	-	-
Insertion Loss (1574.42~1576.42MHz) IL	dB	-	0.85	1.3	-
Insertion Loss (1597.55~1605.89MHz) IL	dB	-	0.95	1.3	-
Amplitude ripple (1574.42~1605.89MHz)	dB	-	0.3	0.6	-
Group Delay ripple (1574.42~1605.89MHz)	ns	-	8	15	-
VSWR (1574.42~1605.89 MHz)		-	1.3	2.1	-
Attenuation (Reference level from 0dB)					
D.C. ~ 915MHz	dB	18	21	-	-
915 ~ 1525MHz	dB	17	19	-	-
1660 ~ 4500MHz	dB	17	20	-	-
4500 ~ 6000MHz	dB	12	32	-	-
Temperature Coefficient of Frequency	ppm/°C	-	-36	-	-

SAW Filter 1590.1550MHz
Part No: MP06037

Model: TA1500A
Rev No: 2

F. FREQUENCY CHARACTERISTICS:

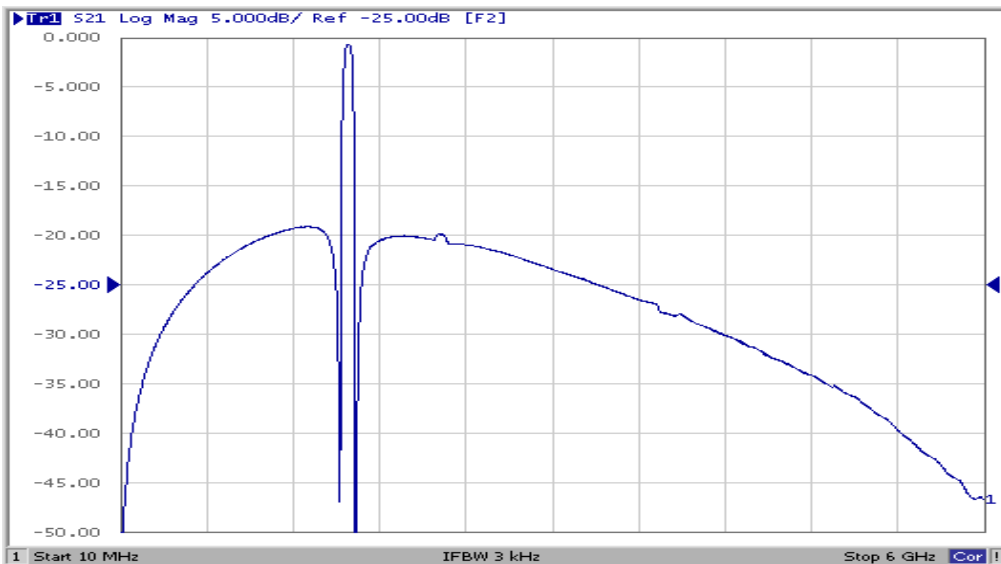
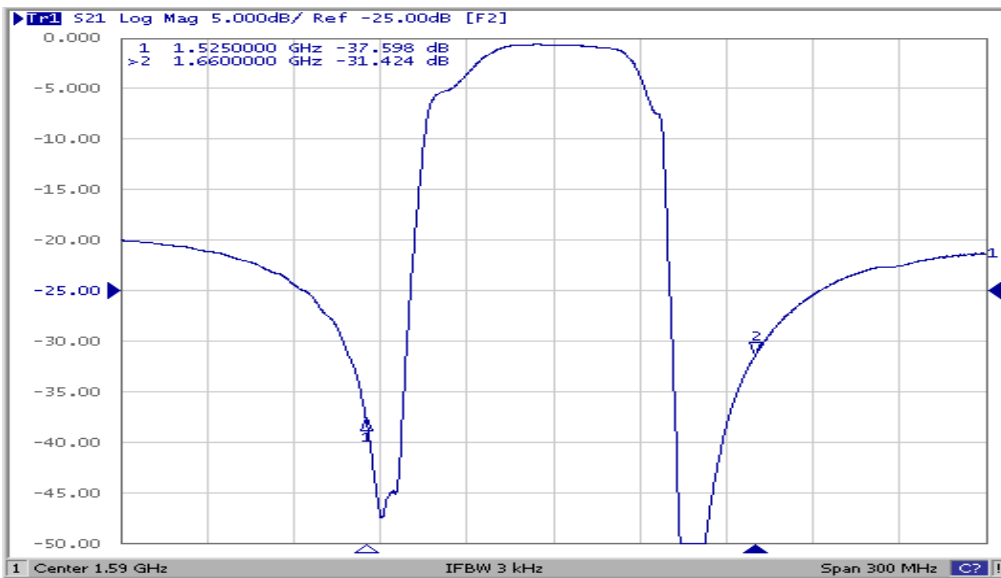
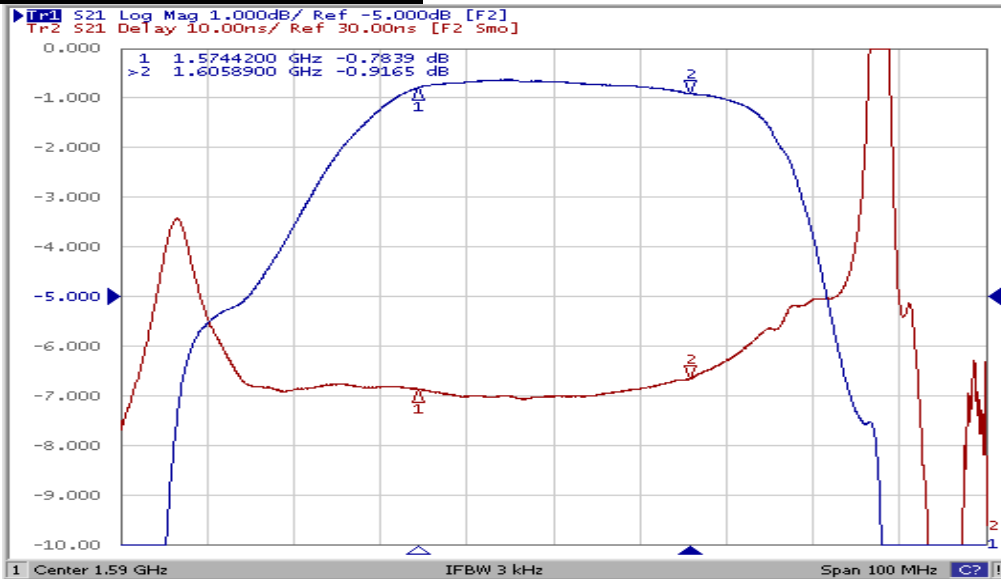

SAW Filter 1590.1550MHz
Part No: MP06037

Model: TA1500A
Rev No: 2

Reflection Functions

S11

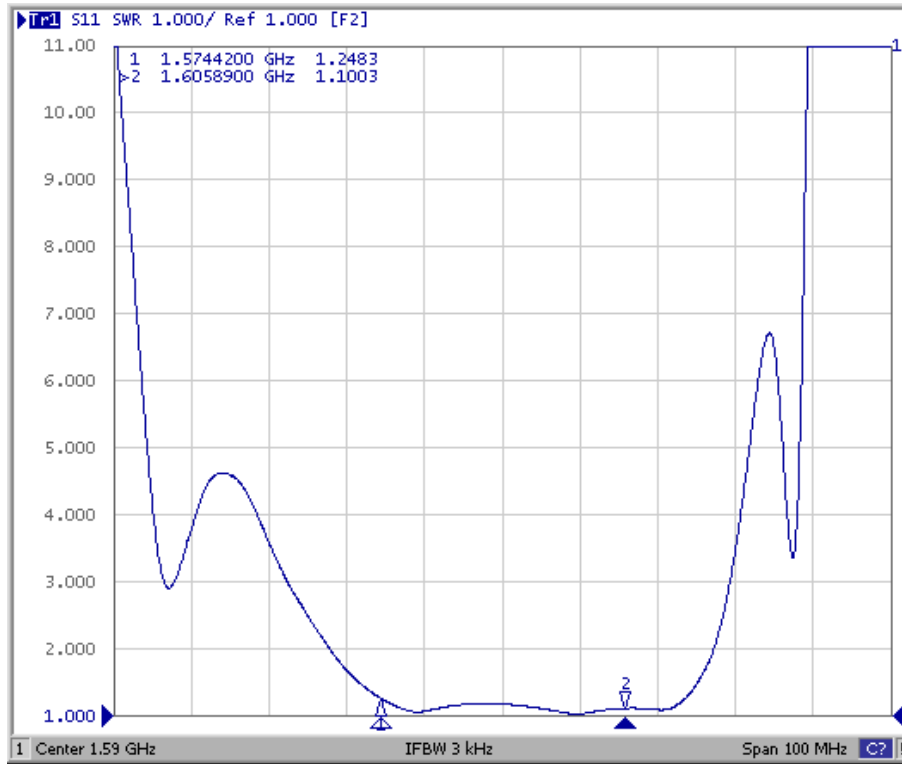

S22

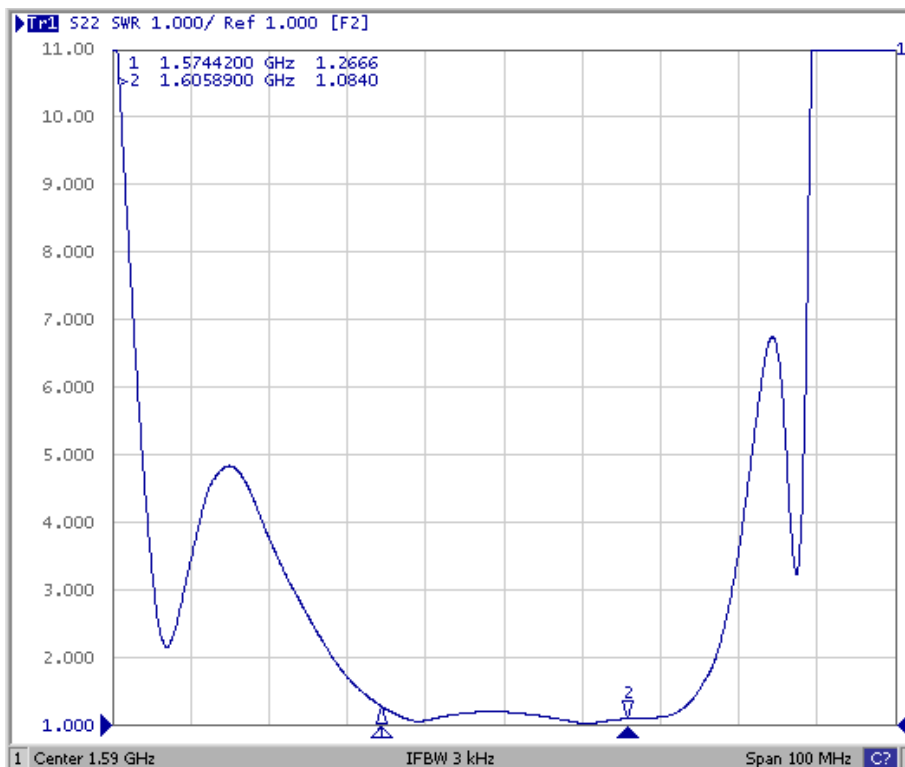

SAW Filter 1590.1550MHz
Part No: MP06037

Model: TA1500A
Rev No: 2

G. PACKING:

1. Reel Dimension (Please refer to FR-75D10 for packing quantity)

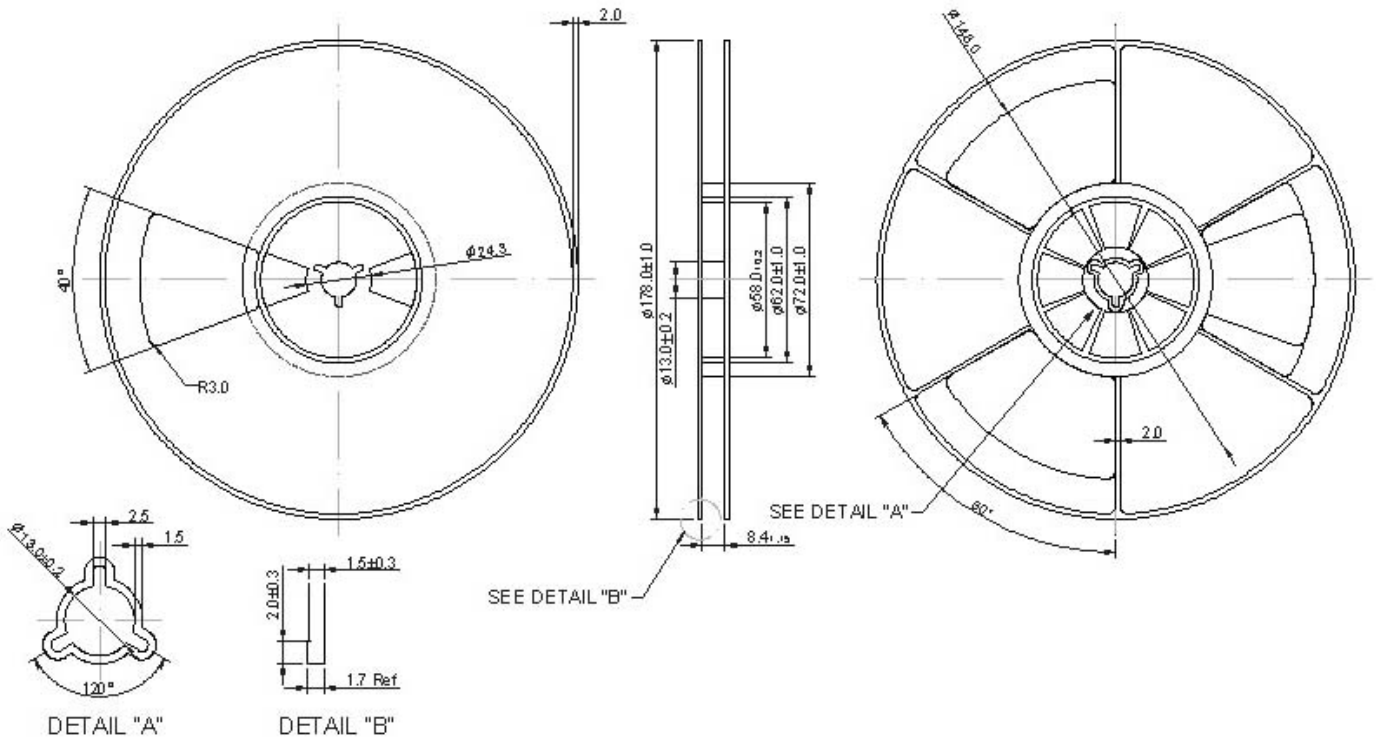

2. Tape Dimension

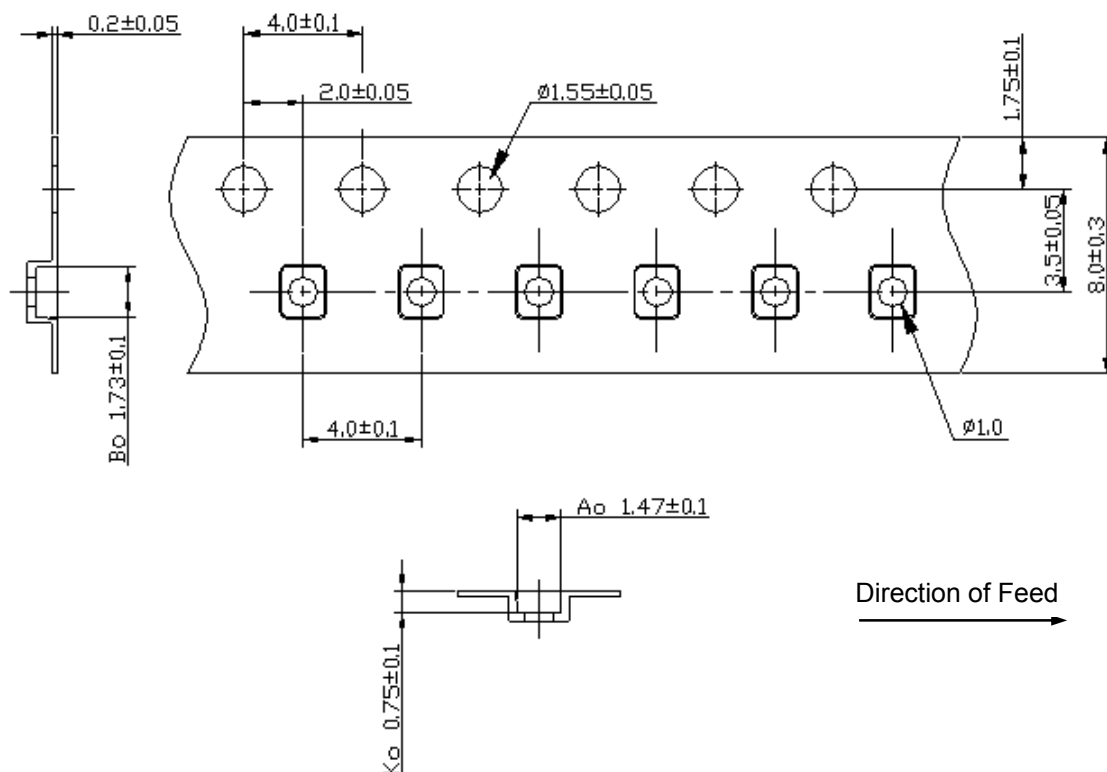

SAW Filter 1590.1550MHz
Part No: MP06037

Model: TA1500A
Rev No: 2

H. RECOMMENDED REFLOW PROFILE:

1. Preheating shall be fixed at 150 ~ 180°C for 60 ~ 90 seconds.
2. Ascending time to preheating temperature 150°C shall be 30 seconds min.
3. Heating shall be fixed at 220°C for 50 ~ 80 seconds and at 245 ~ 260°C peak (min. 10sec).
4. Time: 2 times.

