

3.2×2.5mm for Automotive

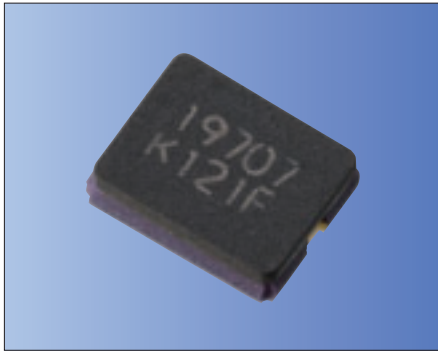

RoHS Compliant

Features

- Crystal unit for automotive electronics
- Improved solderability
- Small and low profile (3.2×2.5×0.85mm)
- Ceramic package
- Reflow compatible
- Acceptable heat cycle solder junction for 3000 cycle (-40 to +125°C)
- AEC-Q200 qualified

Applications

- ECU
- TPMS
- High-Speed Automotive Network

How to Order

CX3225GA 16000 DO P T V CC
 ① ② ③ ④ ⑤ ⑥ ⑦

- ① Series
- ② Frequency
- ③ Load Capacitance
- ④ Frequency Tolerance
- ⑤ Operating Temp. Range
- ⑥ Frequency Temp. Stability
- ⑦ Individual Specification (STD Specification is "CC")

DO	8 pF	P	±50×10 ⁻⁶
TV	-40 to +150°C		±150×10 ⁻⁶

Packaging (Tape & Reel 3000 pcs./ reel)

Specifications

Item	Symbol	Specification	Units	Remarks
Frequency Range	f _{nom}	8000 to 54000	kHz	
Overtone Order	OT	Fundamental	—	
Load Capacitance	CL	8	pF	Please contact us for other Load Capacitance.
Frequency Tolerance	f _{tol}	±50	×10 ⁻⁶	25°C±3°C
Motional Series Resistance	R1	Table 1	ohm	
Drive Level	DL	Table 2	μW	
Operating Temp. Range	T _{use}	-40 to +150	°C	
Storage Temp. Range	T _{stg}	-40 to +150	°C	
Frequency Temp. Characteristics	f _{tem}	±150	×10 ⁻⁶	Freq. deviation from the value at 25°C

Please contact us for other specifications.

Table1 Motional Series Resistance

Frequency Range	Motional Series Resistance
8000 ≤ f _{nom} < 9800kHz	500Ω max.
9800 ≤ f _{nom} < 13560kHz	200Ω max.
13560 ≤ f _{nom} < 16000kHz	120Ω max.
16000 ≤ f _{nom} ≤ 54000kHz	100Ω max.

Table2 Level of Drive

Frequency Range	Level of Drive
8000 ≤ f _{nom} ≤ 54000kHz	10μW (200μW max.)

Dimensions

(Unit: mm)

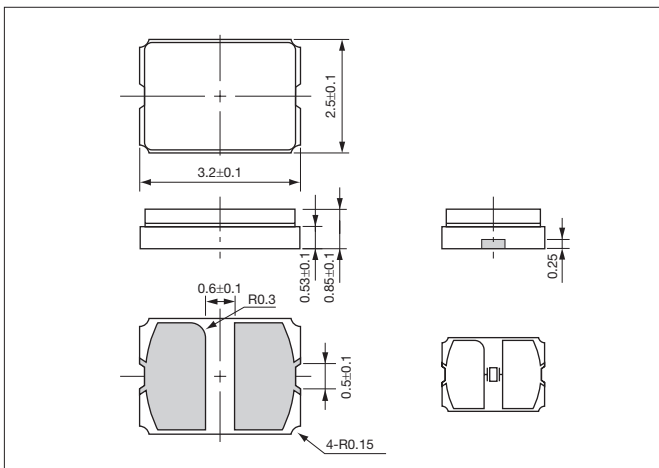

Recommended Land Pattern

(Unit: mm)

