

DIESEL GENERATOR SET

MTU 12V4000 DS1550

STANDBY POWER: 1550 kWel

380V/60 Hz/Water Charge Air Cooling/Fuel Consumption Optimized

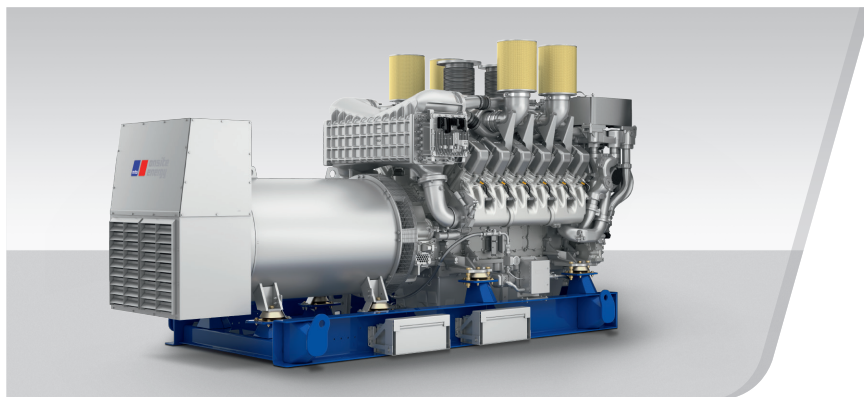

Optional equipment and finishing shown. Standard may vary.

PRODUCT HIGHLIGHTS

// Benefits

- Low fuel consumption
- Optimized system integration ability
- High reliability
- High availability of power
- Long maintenance intervals

// MTU Onsite Energy is a single-source supplier

// Support

- Global product support offered

// Standards

- Engine-generator set is designed and manufactured in facilities certified to standards ISO 2008:9001 and ISO 2004:14001
- Generator set complies to ISO 8528
- Generator meets NEMA MG1, BS5000, ISO, DIN EN and IEC standards
- NFPA 110

// Power Rating

- System rating: 650 kVA - 1700 kVA
- Accepts rated load in one step per NFPA 110
- Generator set complies to G3 according to ISO 8528-5
- Generator set exceeds load steps according to ISO 8528-5

// Performance Assurance Certification (PAC)

- Engine-generator set tested to ISO 8528-5 for transient response
- 85% load factor
- Verified product design, quality and performance integrity
- All engine systems are prototype and factory tested

// Complete range of accessories available

- Control panel
- Fuel system
- Fuel connections with shut-off valve mounted to base frame
- Starting/charging system

// Emissions

- Fuel consumption optimized

// Certifications

- CE certification option

APPLICATION DATA^①

// Engine

Manufacturer	MTU
Model	12V4000G43
Type	4-cycle
Arrangement	12V
Displacement: l	57.2
Bore: mm	170
Stroke: mm	210
Compression ratio	16.4
Rated speed: rpm	1800
Engine governor	ADEC (ECU 7)
Max power: kWm	1736
Air cleaner	Dry

// Fuel System

Maximum fuel lift: m	5
Total fuel flow: l/min	16

// Fuel Consumption^②

	l/hr	g/kwh
At 100% of power rating:	420.4	201
At 75% of power rating:	312.2	199
At 50% of power rating:	221.7	212

// Liquid Capacity (Lubrication)

Total oil system capacity: l	260
Engine jacket water capacity: l	160
Intercooler coolant capacity: l	40

// Combustion Air Requirements

Combustion air volume: m ³ /s	2.3
Max. air intake restriction: mbar	50

// Cooling/Radiator System

Coolant flow rate (HT circuit): m ³ /h	67
Coolant flow rate (LT circuit): m ³ /h	35
Heat rejection to coolant: kW	640
Heat radiated to charge air cooling: kW	410
Heat radiated to ambient: kW	75

// Exhaust System

Exhaust gas temp. (after turbocharger): °C	430
Exhaust gas volume: m ³ /s	5.4
Maximum allowable back pressure: mbar	85
Minimum allowable back pressure: mbar	30

① All data refers only to the engine and is based on ISO standard conditions (25°C and 100m above sea level).

② Values referenced are in accordance with ISO 3046-1. Conversion calculated with fuel density of 0.83 g/ml.
All fuel consumption values refer to rated engine power.

STANDARD AND OPTIONAL FEATURES

// System Ratings (kW/kVA)

	MTU 12V4000 DS1550
	Standby Power
Voltage: V	380
Phases	3
Frequency: Hz	60
Power output: kWel	1550
Power output: kVA*	1938
Rated AMPS	2944
Generator model	Marathon 744RSL7091

* $\cos \phi = 0,8$

// Engine

- 4-Cycle
- Standard single stage air filter
- Oil drain extension & shut-off valve
- Closed crankcase ventilation
- Governor-electronic isochronous
- Common rail fuel injection
- Fuel consumption optimized engine

// Generator

- NEMA MG1, BS5000, ISO, DIN EN and IEC standards
- Self-ventilated
- Superior voltage waveform
- Solid state, volts-per-Hertz regulator
- No load to full load regulation
- $\pm 0.25\%$ voltage regulation no load to full load
- Brushless alternator with brushless pilot exciter
- 4 pole, rotating field
- Sustained short circuit current of up to 300% of the rated current for up to 10 seconds
- Marathon low voltage generator

// Cooling System

- Jacket water pump
- Thermostat(s)
- Water charge air cooling
- Jacket water heater

STANDARD AND OPTIONAL FEATURES, CONTINUATION

// Control Panel

- Pre-wired control cabinet for easy application of customized controller (V1+)
- Island operation (V2)
- Automatic mains failure operation with ATS (V3a)
- Automatic mains failure operation incl. control of generator and mains breaker (V3b)
- Island parallel operation of multiple gensets (V4)
- Automatic mains failure operation with short (< 10s) mains parallel overlap synchronization (V5)
- Mains parallel operation of a single genset (V6)
- Mains parallel operation of multiple gensets (V7)
- Basler controller
- Deif controller
- Complete system metering
- Digital metering
- Engine parameters
- Generator protection functions
- Engine protection
- SAE J1939 engine ECU communications
- Parametrization software
- Multilingual capability
- Multiple programmable contact inputs
- Multiple contact outputs
- Event recording
- IP 54 front panel rating with integrated gasket
- Different expansion modules
- Remote annunciator
- Daytank control
- Generator winding temperature monitoring
- Generator bearing temperature monitoring
- Differential protection with multi-function protection relay
- Modbus RTU-TCP gateway

// Fuel System

- Flexible fuel connectors mounted to base frame
- Fuel filter with water separator
- Switchable fuel filter with water separator
- Separate fuel cooler

// Starting/Charging System

- 24V starter
- Starter batteries
- Battery rack & cables
- Battery charger

// Mounting System

- Welded base frame
- Resilient engine and generator mounting
- Modular base frame design

// Exhaust System

- Exhaust bellows with connection flange
- Y-connection-pipe

WEIGHTS AND DIMENSIONS

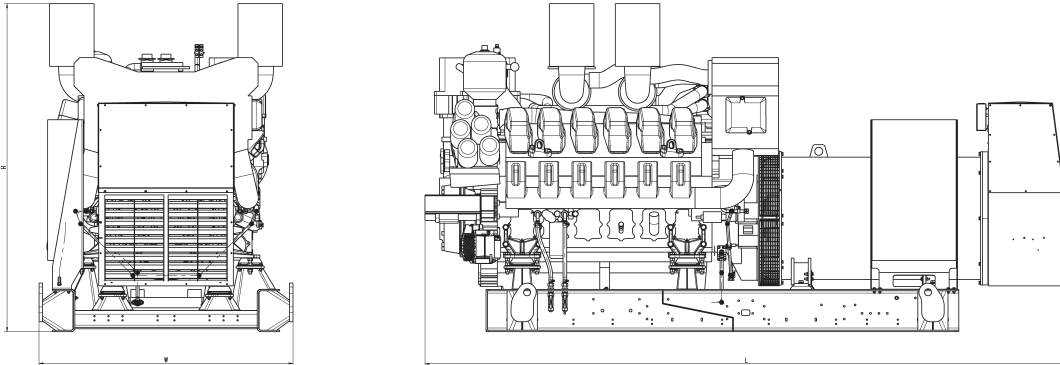

Drawing above for illustration purposes only, based on a standard open power 400 Volt engine-generator set. Lengths may vary with other voltages. Do not use for installation design. See website for unit specific template drawings.

System	Dimensions (LxWxH)	Weight (dry/less tank)
Open Power Unit (OPU)	4583 x 1836 x 2330 mm	10877 kg

Weights and dimensions are based on open power units and are estimates only. Consult the factory for accurate weights and dimensions for your specific engine-generator set.

SOUND DATA

// Consult your local MTU Onsite Energy distributor for sound data.

EMISSIONS DATA

// Consult your local MTU Onsite Energy distributor for emissions data.

RATING DEFINITIONS AND CONDITIONS

// Standby ratings apply to installations served by a reliable utility source. The standby rating is applicable to varying loads for the duration of a power outage. No overload capability for this rating. Ratings are in accordance with ISO 8528-1, ISO-3046-1, BS 5514 and AS 2789. Average Load Factor: $\leq 85\%$. Operating hours/year: max. 500.

// Deration factor:

Altitude: Consult your local MTU Onsite Energy Power Generation distributor for altitude derations.

Temperature: Consult your local MTU Onsite Energy Power Generation distributor for temperature derations.

Rated power is available up to 40°C and 400m above sea level.

Materials and specifications subject to change without notice.