

1. Mechanical Dimensions:

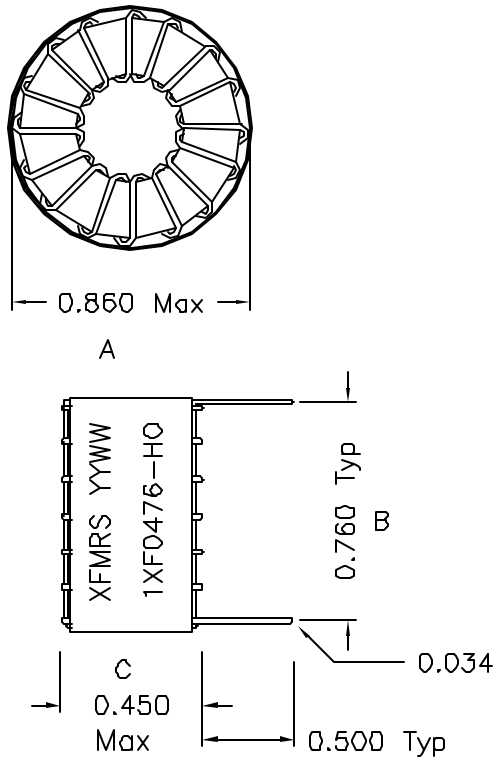

WINDING DETAIL:

STRIP AND TIN TO MOUNT PLAIN
VARNISH REQUIRED

DOC. REV: A/1

2. Schematic:

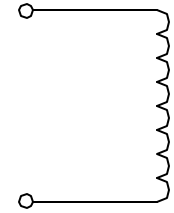

3. Electrical Specifications:

Inductance: 47.0uH ±20% @1.0KHz,1.0V

Inductance: 25.3uH±20% @1.0KHz,1.0V 5.2Adc

DC Resistance: 0.024 Ohms Max.

Notes:

1. Solderability: Leads shall meet MIL-STD-202G, Method 208H for solderability.
2. Flammability: UL94V-0
3. ASTM oxygen index: > 28%
4. Insulation System: Class F 155°C. UL file E151556
5. Operating Temperature Range: All listed parameters are to be within tolerance from -55°C to +125°C
6. Storage Temperature Range: -55°C to +125°C
7. Aqueous wash compatible
8. Electrical and mechanical specifications 100% tested
9. RoHS Compliant Component

PROPRIETARY Document is the property of XFMRS Group & is not allowed to be duplicated without authorization.

XFMRS Inc www.XFMRS.com		Title: HORIZONTAL OPEN TOROID	
UNLESS OTHERWISE SPECIFIED TOLERANCES: N/A	P/N: 1XF0476-H0		REV. A
	DWN.	李小锋	Jan-22-07
Dimensions in INCH	CHK.	廖玉坤	Jan-22-06
SHEET 1 OF 1	APP.	BW	Jan-22-07