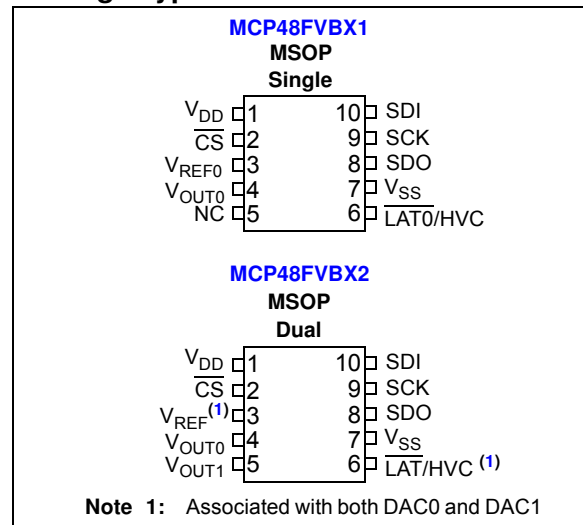


## 8-/10-/12-Bit Single/Dual Voltage Output Volatile Digital-to-Analog Converters with SPI Interface

### Features

- Operating Voltage Range:
  - 2.7V to 5.5V - full specifications
  - 1.8V to 2.7V - reduced device specifications
- Output Voltage Resolutions:
  - 8-bit: **MCP48FVB0X** (256 Steps)
  - 10-bit: **MCP48FVB1X** (1024 Steps)
  - 12-bit: **MCP48FVB2X** (4096 Steps)
- Rail-to-Rail Output
- Fast Settling Time of 7.8  $\mu$ s (typical)
- DAC Voltage Reference Source Options:
  - Device  $V_{DD}$
  - External  $V_{REF}$  pin (buffered or unbuffered)
  - Internal Band Gap (1.22V typical)
- Output Gain Options:
  - Unity (1x)
  - 2x
- Power-on/Brown-out Reset Protection
- Power-Down Modes:
  - Disconnects output buffer (High Impedance)
  - Selection of  $V_{OUT}$  pull-down resistors (100 k $\Omega$  or 1 k $\Omega$ )
- Low Power Consumption:
  - Normal operation: <180  $\mu$ A (Single), 380  $\mu$ A (Dual)
  - Power-down operation: 650 nA typical
- SPI Interface:
  - Supports '00' and '11' modes
  - Up to 20 MHz writes and 10 MHz reads
  - Input buffers support interfacing to low-voltage digital devices
- Package Types: 10-lead MSOP
- Extended Temperature Range: -40°C to +125°C

### Package Types



### General Description

The MCP48FVBXX are Single- and Dual-channel 8-bit, 10-bit, and 12-bit buffered voltage output Digital-to-Analog Converters (DAC) with volatile memory and an SPI serial interface.

The  $V_{REF}$  pin, the device  $V_{DD}$  or the internal band gap voltage can be selected as the DAC's reference voltage. When  $V_{DD}$  is selected,  $V_{DD}$  is connected internally to the DAC reference circuit. When the  $V_{REF}$  pin is used, the user can select the output buffer's gain to be 1 or 2. When the gain is 2, the  $V_{REF}$  pin voltage should be limited to a maximum of  $V_{DD}/2$ .

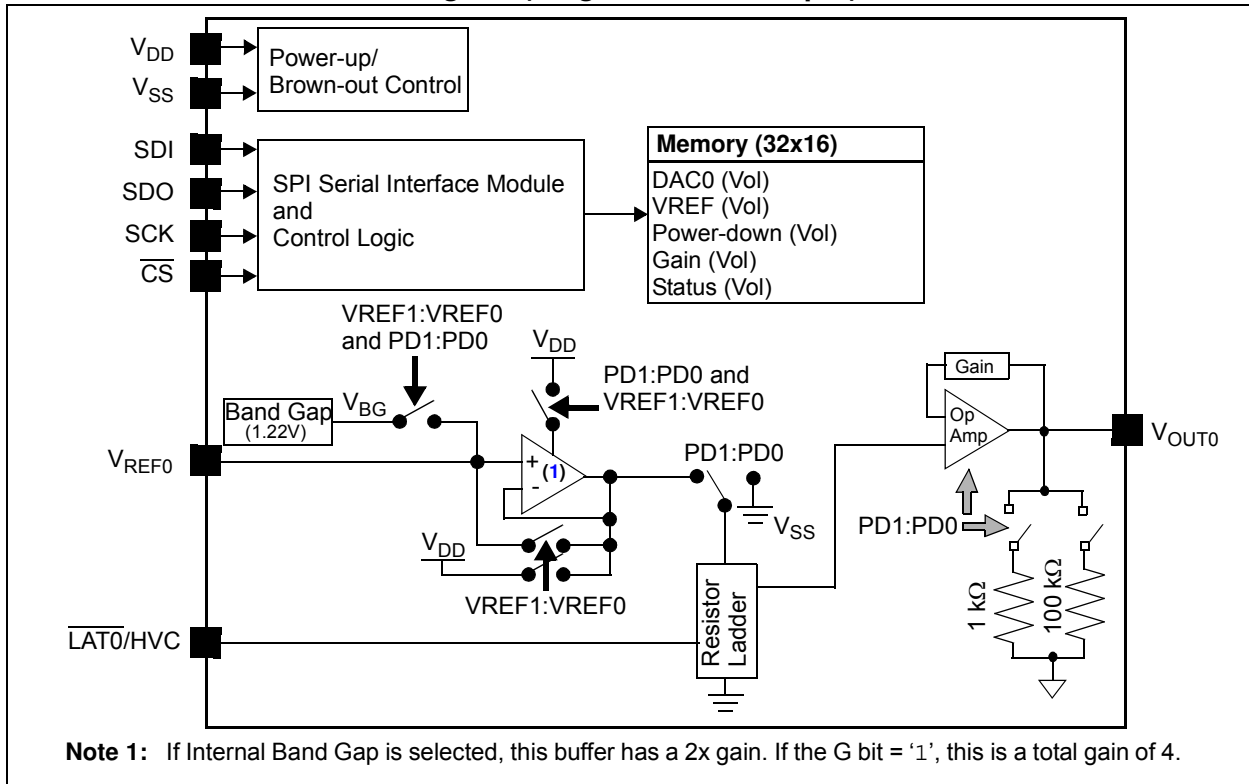
These devices have an SPI-compatible serial interface. Write commands are supported up to 20 MHz while read commands are supported up to 10 MHz.

### Applications

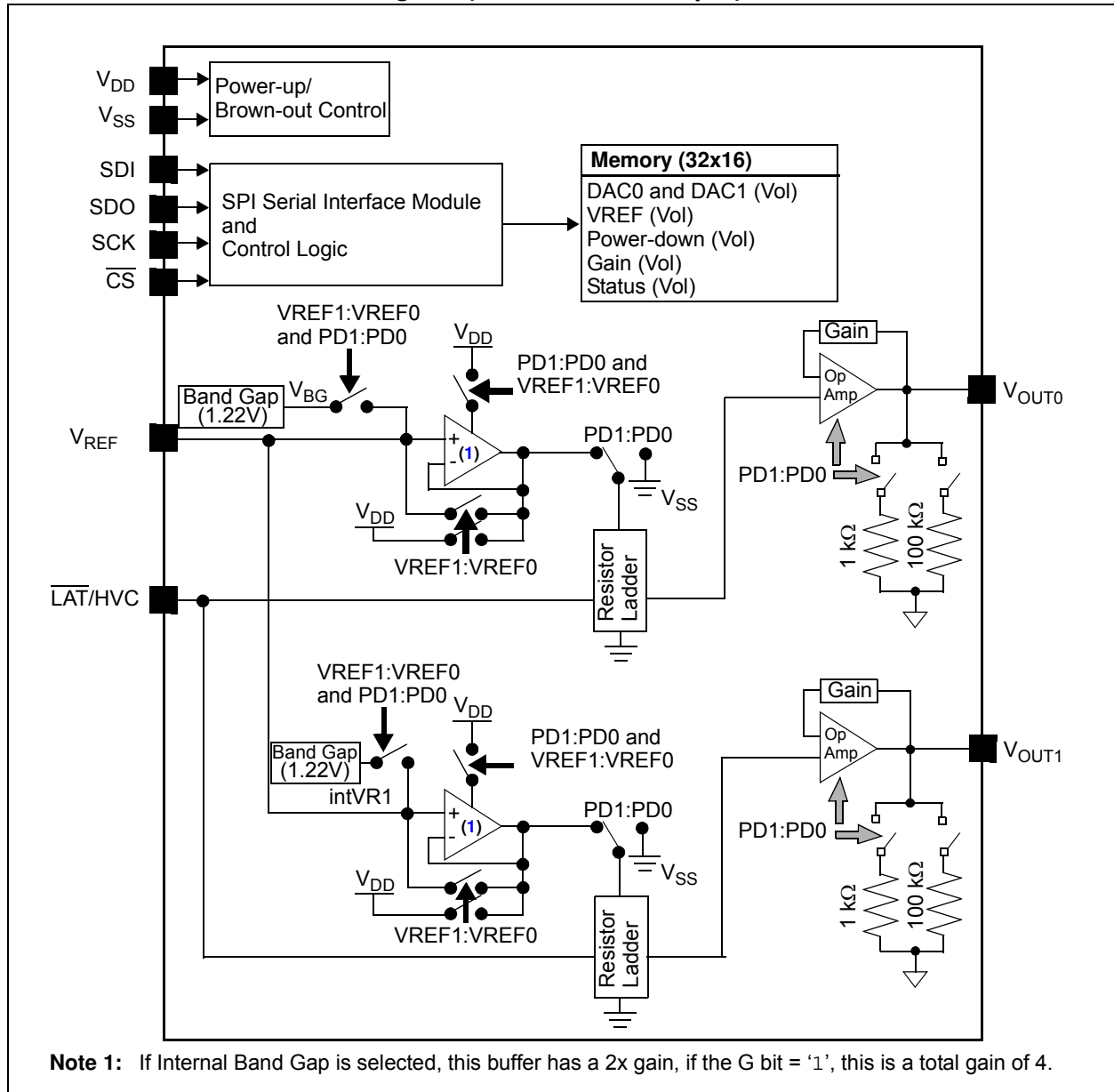
- Set Point or Offset Trimming
- Sensor Calibration
- Low-Power Portable Instrumentation
- PC Peripherals
- Data Acquisition Systems
- Motor Control

# MCP48FVBXX

## MCP48FVBX1 Device Block Diagram (Single-Channel Output)



## MCP48FVBX2 Device Block Diagram (Dual-Channel Output)



# MCP48FVBXX

## Device Features

Device	# of Channels	Resolution (bits)	Control Interface	DAC Output POR/BOR Setting <sup>(1)</sup>	# of V <sub>REF</sub> Inputs	Internal band gap ?	# of LAT Inputs	Memory	Specified Operating Range (V <sub>DD</sub> ) <sup>(2)</sup>
MCP48FVB01	1	8	SPI	7Fh	1	Yes	1	RAM	1.8V to 5.5V
MCP48FVB11	1	10	SPI	1FFh	1	Yes	1	RAM	1.8V to 5.5V
MCP48FVB21	1	12	SPI	7FFh	1	Yes	1	RAM	1.8V to 5.5V
MCP48FVB02	2	8	SPI	7Fh	1	Yes	1	RAM	1.8V to 5.5V
MCP48FVB12	2	10	SPI	1FFh	1	Yes	1	RAM	1.8V to 5.5V
MCP48FVB22	2	12	SPI	7FFh	1	Yes	1	RAM	1.8V to 5.5V
MCP48FEB01	1	8	SPI	7Fh	1	Yes	1	EEPROM	1.8V to 5.5V
MCP48FEB11	1	10	SPI	1FFh	1	Yes	1	EEPROM	1.8V to 5.5V
MCP48FEB21	1	12	SPI	7FFh	1	Yes	1	EEPROM	1.8V to 5.5V
MCP48FEB02	2	8	SPI	7Fh	1	Yes	1	EEPROM	1.8V to 5.5V
MCP48FEB12	2	10	SPI	1FFh	1	Yes	1	EEPROM	1.8V to 5.5V
MCP48FEB22	2	12	SPI	7FFh	1	Yes	1	EEPROM	1.8V to 5.5V
MCP47FVB01	1	8	I <sup>2</sup> C	7Fh	1	Yes	1	RAM	1.8V to 5.5V
MCP47FVB11	1	10	I <sup>2</sup> C	1FFh	1	Yes	1	RAM	1.8V to 5.5V
MCP47FVB21	1	12	I <sup>2</sup> C	7FFh	1	Yes	1	RAM	1.8V to 5.5V
MCP47FVB02	2	8	I <sup>2</sup> C	7Fh	1	Yes	1	RAM	1.8V to 5.5V
MCP47FVB12	2	10	I <sup>2</sup> C	1FFh	1	Yes	1	RAM	1.8V to 5.5V
MCP47FVB22	2	12	I <sup>2</sup> C	7FFh	1	Yes	1	RAM	1.8V to 5.5V
MCP47FEB01	1	8	I <sup>2</sup> C	7Fh	1	Yes	1	EEPROM	1.8V to 5.5V
MCP47FEB11	1	10	I <sup>2</sup> C	1FFh	1	Yes	1	EEPROM	1.8V to 5.5V
MCP47FEB21	1	12	I <sup>2</sup> C	7FFh	1	Yes	1	EEPROM	1.8V to 5.5V
MCP47FEB02	2	8	I <sup>2</sup> C	7Fh	1	Yes	1	EEPROM	1.8V to 5.5V
MCP47FEB12	2	10	I <sup>2</sup> C	1FFh	1	Yes	1	EEPROM	1.8V to 5.5V
MCP47FEB22	2	12	I <sup>2</sup> C	7FFh	1	Yes	1	EEPROM	1.8V to 5.5V

**Note 1:** Factory Default value. The DAC output POR/BOR value can be modified via the nonvolatile DAC output register(s) (available only on nonvolatile devices (MCP4XFEBXX)).

**2:** Analog output performance specified from 2.7V to 5.5V.

## 1.0 ELECTRICAL CHARACTERISTICS

### Absolute Maximum Ratings (†)

Voltage on $V_{DD}$ with respect to $V_{SS}$ .....	-0.6V to +6.5V
Voltage on all pins with respect to $V_{SS}$ .....	-0.6V to $V_{DD}+0.3V$
Input clamp current, $I_{IK}$ ( $V_I < 0$ , $V_I > V_{DD}$ , $V_I > V_{PP}$ on HV pins) .....	$\pm 20$ mA
Output clamp current, $I_{OK}$ ( $V_O < 0$ or $V_O > V_{DD}$ ).....	$\pm 20$ mA
Maximum current out of $V_{SS}$ pin (Single).....	50 mA
(Dual).....	100 mA
Maximum current into $V_{DD}$ pin (Single).....	50 mA
(Dual).....	100 mA
Maximum current sourced by the $V_{OUT}$ pin .....	20 mA
Maximum current sunk by the $V_{OUT}$ pin.....	20 mA
Maximum current sunk by the $V_{REF}$ pin .....	125 $\mu$ A
Maximum input current source/sunk by SDI, SCK, and $\overline{CS}$ pins .....	2 mA
Maximum output current sunk by SDO Output pin .....	25 mA
Total power dissipation <sup>(1)</sup> .....	400 mW
Package power dissipation ( $T_A = +50^\circ\text{C}$ , $T_J = +150^\circ\text{C}$ )	
MSOP-10 .....	490 mW
ESD protection on all pins .....	$\geq \pm 4$ kV (HBM)
.....	$\geq \pm 400$ V (MM)
.....	$\geq \pm 1.5$ kV (CDM)
Latch-Up (per JEDEC JESD78A) @ $+125^\circ\text{C}$ .....	$\pm 100$ mA
Storage temperature .....	$-65^\circ\text{C}$ to $+150^\circ\text{C}$
Ambient temperature with power applied .....	$-55^\circ\text{C}$ to $+125^\circ\text{C}$
Soldering temperature of leads (10 seconds).....	$+300^\circ\text{C}$
Maximum Junction Temperature ( $T_J$ ).....	$+150^\circ\text{C}$

† **Notice:** Stresses above those listed under “Maximum Ratings” may cause permanent damage to the device. This is a stress rating only and functional operation of the device at those or any other conditions above those indicated in the operational listings of this specification is not implied. Exposure to maximum rating conditions for extended periods may affect device reliability.

**Note 1:** Power dissipation is calculated as follows:

$$P_{DIS} = V_{DD} \times \{I_{DD} - \sum I_{OH}\} + \sum \{(V_{DD} - V_{OH}) \times I_{OH}\} + \sum (V_{OL} \times I_{OL})$$

# MCP48FVBXX

## DC CHARACTERISTICS

Parameters	Sym.	Min.	Typ.	Max.	Units	Conditions
Supply Voltage	$V_{DD}$	2.7	—	5.5	V	
		1.8	—	2.7	V	DAC operation (reduced analog specifications) and Serial Interface
$V_{DD}$ Voltage (rising) to ensure device Power-on Reset	$V_{POR/BOR}$	—	—	1.7	V	RAM retention voltage ( $V_{RAM}$ ) < $V_{POR}$ $V_{DD}$ voltages greater than $V_{POR/BOR}$ limit Ensure that device is out of reset.
$V_{DD}$ Rise Rate to ensure Power-on Reset	$V_{DDRR}$	(Note 3)			V/ms	
High-Voltage Commands Voltage Range (HVC pin)	$V_{HV}$	$V_{SS}$	—	12.5	V	The HVC pin will be at one of three input levels ( $V_{IL}$ , $V_{IH}$ or $V_{IHH}$ ) <sup>(1)</sup>
High-Voltage Input Entry Voltage	$V_{IHHEN}$	9.0	—	—	V	Threshold for Entry into WiperLock Technology - for compatibility with MCP48FEBxx devices
High-Voltage Input Exit Voltage	$V_{IHHEX}$	—	—	$V_{DD} + 0.8\text{V}$	V	(Note 2)
Power-on Reset to Output-Driven Delay	$T_{PORD}$	—	25	50	$\mu\text{s}$	$V_{DD}$ rising, $V_{DD} > V_{POR}$

**Note 1** This parameter is ensured by design.

**Note 2** This parameter is ensured by characterization.

**Note 3** POR/BOR voltage trip point is not slope dependent. Hysteresis implemented with time delay.

## DC CHARACTERISTICS (CONTINUED)

Parameters	Sym.	Min.	Typ.	Max.	Units	Conditions		
<b>Standard Operating Conditions (unless otherwise specified):</b> Operating Temperature: $-40^{\circ}\text{C} \leq T_A \leq +125^{\circ}\text{C}$ (Extended) Unless otherwise noted, all parameters apply across these specified operating ranges: $V_{DD} = +2.7\text{V to } 5.5\text{V}$ , $V_{REF} = +2.048\text{V to } V_{DD}$ , $V_{SS} = 0\text{V}$ $G_x = '0'$ , $R_L = 5\text{ k}\Omega$ from $V_{OUT}$ to $V_{SS}$ , $C_L = 100\text{ pF}$ Typical specifications represent values for $V_{DD} = 5.5\text{V}$ , $T_A = +25^{\circ}\text{C}$ .								
Supply Current	$I_{DD}$	—	—	320	$\mu\text{A}$	Single	1MHz <sup>(2)</sup>	Serial Interface Active (Not High-Voltage Command) $VRxB:VRxA = '01'$ <sup>(6)</sup> $V_{OUT}$ is unloaded, $V_{DD} = 5.5\text{V}$ Volatile DAC Register = 000h
		—	—	910	$\mu\text{A}$		10 MHz <sup>(2)</sup>	
		—	—	1.7	mA		20 MHz	
		—	—	510	$\mu\text{A}$	Dual	1 MHz <sup>(2)</sup>	
		—	—	1.1	mA		10 MHz <sup>(2)</sup>	
		—	—	1.85	mA		20 MHz	
		—	—	250	$\mu\text{A}$	Single	1 MHz <sup>(2)</sup>	Serial Interface Active (Not High-Voltage Command) $VRxB:VRxA = '10'$ <sup>(4)</sup> $V_{OUT}$ is unloaded. $V_{REF} = V_{DD} = 5.5\text{V}$ Volatile DAC Register = 000h
		—	—	840	$\mu\text{A}$		10 MHz <sup>(2)</sup>	
		—	—	1.65	mA		20 MHz <sup>(2)</sup>	
		—	—	380	$\mu\text{A}$	Dual	1 MHz <sup>(2)</sup>	
		—	—	970	$\mu\text{A}$		10 MHz <sup>(2)</sup>	
		—	—	1.75	mA		20 MHz <sup>(2)</sup>	
		—	—	180	$\mu\text{A}$	Single	Serial Interface Inactive <sup>(2)</sup> (Not High-Voltage Command) $VRxB:VRxA = '00'$ $SCK = SDI = V_{SS}$ $V_{OUT}$ is unloaded. Volatile DAC Register = 000h	
		—	—	380	$\mu\text{A}$	Dual		
		—	—	180	$\mu\text{A}$	Single	Serial Interface Inactive <sup>(2)</sup> (Not High-Voltage Command) $VRxB:VRxA = '11'$ , $V_{REF} = V_{DD}$ $SCK = SDI = V_{SS}$ $V_{OUT}$ is unloaded. Volatile DAC Register = 000h	
—	—	380	$\mu\text{A}$	Dual				
—	145	180	$\mu\text{A}$	Single	HVC = 12.5V (High-Voltage Command) Serial Interface Inactive			
—	260	400	$\mu\text{A}$	Dual	$V_{REF} = V_{DD} = 5.5\text{V}$ , $\overline{LAT}/HVC = V_{IH}$ DAC registers = 000h $V_{OUT}$ pins are unloaded			
Power-Down Current	$I_{DDP}$	—	0.65	3.8	$\mu\text{A}$	$PDxB:PDxA = '01'$ <sup>(5)</sup> $V_{OUT}$ not connected		

**Note 2** This parameter is ensured by characterization.

**Note 4** Supply current is independent of current through the resistor ladder in mode  $VRxB:VRxA = '10'$ .

**Note 5** The  $PDxB:PDxA = '01'$ ,  $'10'$ , and  $'11'$  configurations should have the same current.

**Note 6** By design, this is the worst-case current mode.

# MCP48FVBXX

## DC CHARACTERISTICS (CONTINUED)

Parameters	Sym.	Min.	Typ.	Max.	Units	Conditions	
<b>Standard Operating Conditions (unless otherwise specified):</b> Operating Temperature: $-40^{\circ}\text{C} \leq T_A \leq +125^{\circ}\text{C}$ (Extended) Unless otherwise noted, all parameters apply across these specified operating ranges: $V_{DD} = +2.7\text{V}$ to $5.5\text{V}$ , $V_{REF} = +2.048\text{V}$ to $V_{DD}$ , $V_{SS} = 0\text{V}$ $Gx = '0'$ , $R_L = 5\text{ k}\Omega$ from $V_{OUT}$ to $V_{SS}$ , $C_L = 100\text{ pF}$ Typical specifications represent values for $V_{DD} = 5.5\text{V}$ , $T_A = +25^{\circ}\text{C}$ .							
Resistor Ladder Resistance	$R_L$	100	140	180	$\text{k}\Omega$	$1.8\text{V} \leq V_{DD} \leq 5.5\text{V}$ $V_{REF} \geq 1.0\text{V}$ (7)	
Resolution (# of Resistors and # of Taps) (see B.1 "Resolution")	N	256			Taps	8-bit	No Missing Codes
		1024			Taps	10-bit	No Missing Codes
		4096			Taps	12-bit	No Missing Codes
Nominal $V_{OUT}$ Match (11)	$ V_{OUT} - V_{OUTMEAN}  / V_{OUTMEAN}$	—	0.5	1.0	%	$2.7\text{V} \leq V_{DD} \leq 5.5\text{V}$ (2)	
		—	—	1.2	%	1.8V (2)	
$V_{OUT}$ Tempco (See B.19 " $V_{OUT}$ Temperature Coefficient")	$\Delta V_{OUT} / \Delta T$	—	15	—	$\text{ppm}/^{\circ}\text{C}$	Code = Mid-scale (7Fh, 1FFh or 7FFh)	
$V_{REF}$ pin Input Voltage Range	$V_{REF}$	$V_{SS}$	—	$V_{DD}$	V	$1.8\text{V} \leq V_{DD} \leq 5.5\text{V}$ (1)	

**Note 1** This parameter is ensured by design.

**Note 2** This parameter is ensured by characterization.

**Note 7** Resistance is defined as the resistance between the  $V_{REF}$  pin (mode  $VRxB:VRxA = '10'$ ) to  $V_{SS}$  pin. For dual-channel devices (MCP48FVBX2), this is the effective resistance of the each resistor ladder. The resistance measurement is that of the two resistor ladders measured in parallel.

**Note 11** Variation of one output voltage to mean output voltage.

## DC CHARACTERISTICS (CONTINUED)

Parameters	Sym.	Min.	Typ.	Max.	Units	Conditions	
<b>Standard Operating Conditions (unless otherwise specified):</b> Operating Temperature: $-40^{\circ}\text{C} \leq T_A \leq +125^{\circ}\text{C}$ (Extended) Unless otherwise noted, all parameters apply across these specified operating ranges: $V_{DD} = +2.7\text{V}$ to $5.5\text{V}$ , $V_{REF} = +2.048\text{V}$ to $V_{DD}$ , $V_{SS} = 0\text{V}$ $G_x = '0'$ , $R_L = 5\text{ k}\Omega$ from $V_{OUT}$ to $V_{SS}$ , $C_L = 100\text{ pF}$ Typical specifications represent values for $V_{DD} = 5.5\text{V}$ , $T_A = +25^{\circ}\text{C}$ .							
Zero-Scale Error (see <a href="#">B.5 "Zero-Scale Error (<math>E_{ZS})</math>"</a> ) (Code = 000h)	$E_{ZS}$	—	—	0.75	LSb	8-bit	VRxB:VRxA = '11', $G_x = '0'$ $V_{REF} = V_{DD}$ , No Load
		See <a href="#">Section 2.0, "Typical Performance Curves" (2)</a>			LSb		VRxB:VRxA = '00', $G_x = '0'$ $V_{DD} = 5.5\text{V}$ , No Load
		See <a href="#">Section 2.0, "Typical Performance Curves" (2)</a>			LSb		$V_{DD} = 1.8\text{V}$ , $V_{REF} = 1.0\text{V}$ VRxB:VRxA = '10', $G_x = '0'$ , No Load
		See <a href="#">Section 2.0, "Typical Performance Curves" (2)</a>			LSb		$V_{DD} = 1.8\text{V}$ , $V_{REF} = 1.0\text{V}$ VRxB:VRxA = '11', $G_x = '0'$ , No Load
		See <a href="#">Section 2.0, "Typical Performance Curves" (2)</a>			LSb		VRxB:VRxA = '01', $G_x = '0'$ , No Load
		—	—	3	LSb	10-bit	VRxB:VRxA = '11', $G_x = '0'$ $V_{REF} = V_{DD}$ , No Load
		See <a href="#">Section 2.0, "Typical Performance Curves" (2)</a>			LSb		VRxB:VRxA = '00', $G_x = '0'$ $V_{DD} = 5.5\text{V}$ , No Load
		See <a href="#">Section 2.0, "Typical Performance Curves" (2)</a>			LSb		$V_{DD} = 1.8\text{V}$ , $V_{REF} = 1.0\text{V}$ VRxB:VRxA = '10', $G_x = '0'$ , No Load
		See <a href="#">Section 2.0, "Typical Performance Curves" (2)</a>			LSb		$V_{DD} = 1.8\text{V}$ , $V_{REF} = 1.0\text{V}$ VRxB:VRxA = '11', $G_x = '0'$ , No Load
		See <a href="#">Section 2.0, "Typical Performance Curves" (2)</a>			LSb		VRxB:VRxA = '01', $G_x = '0'$ No Load
		—	—	12	LSb	12-bit	VRxB:VRxA = '11', $G_x = '0'$ $V_{REF} = V_{DD}$ , No Load
		See <a href="#">Section 2.0, "Typical Performance Curves" (2)</a>			LSb		VRxB:VRxA = '00', $G_x = '0'$ $V_{DD} = 5.5\text{V}$ , No Load
		See <a href="#">Section 2.0, "Typical Performance Curves" (2)</a>			LSb		$V_{DD} = 1.8\text{V}$ , $V_{REF} = 1.0\text{V}$ VRxB:VRxA = '10', $G_x = '0'$ , No Load
		See <a href="#">Section 2.0, "Typical Performance Curves" (2)</a>			LSb		$V_{DD} = 1.8\text{V}$ , $V_{REF} = 1.0\text{V}$ VRxB:VRxA = '11', $G_x = '0'$ , No Load
		See <a href="#">Section 2.0, "Typical Performance Curves" (2)</a>			LSb		VRxB:VRxA = '01', $G_x = '0'$ No Load
Offset Error (see <a href="#">B.8 "Offset Error Drift (<math>E_{OSD})</math>"</a> )	$E_{OSD}$	-15	$\pm 1.5$	+15	mV	VRxB:VRxA = '00' $G_x = '0'$ No Load	
Offset Voltage Temperature Coefficient	$V_{OSTC}$	—	$\pm 10$	—	$\mu\text{V}/^{\circ}\text{C}$		

**Note 2** This parameter is ensured by characterization.

# MCP48FVBXX

## DC CHARACTERISTICS (CONTINUED)

Parameters	Sym.	Min.	Typ.	Max.	Units	Conditions	
<b>Standard Operating Conditions (unless otherwise specified):</b> Operating Temperature: $-40^{\circ}\text{C} \leq T_A \leq +125^{\circ}\text{C}$ (Extended) Unless otherwise noted, all parameters apply across these specified operating ranges: $V_{DD} = +2.7\text{V}$ to $5.5\text{V}$ , $V_{REF} = +2.048\text{V}$ to $V_{DD}$ , $V_{SS} = 0\text{V}$ $G_x = '0'$ , $R_L = 5\text{ k}\Omega$ from $V_{OUT}$ to GND, $C_L = 100\text{ pF}$ Typical specifications represent values for $V_{DD} = 5.5\text{V}$ , $T_A = +25^{\circ}\text{C}$ .							
Full-Scale Error (see <a href="#">B.4 "Full-Scale Error (<math>E_{FS}</math>)"</a> )	$E_{FS}$	—	—	4.5	LSb	8-bit	Code = FFh, VRxB:VRxA = '11' Gx = '0', $V_{REF} = 2.048\text{V}$ , No Load
		See <a href="#">Section 2.0, "Typical Performance Curves" (2)</a>			LSb		Code = FFh, VRxB:VRxA = '10' Gx = '0', $V_{REF} = 2.048\text{V}$ , No Load
		See <a href="#">Section 2.0, "Typical Performance Curves" (2)</a>			LSb		Code = FFh, VRxB:VRxA = '01' Gx = '0', $V_{REF} = 2.048\text{V}$ , No Load
		See <a href="#">Section 2.0, "Typical Performance Curves" (2)</a>			LSb		Code = FFh, VRxB:VRxA = '00' No Load
		—	—	18	LSb	10-bit	Code = 3FFh, VRxB:VRxA = '11' Gx = '0', $V_{REF} = 2.048\text{V}$ , No Load
		See <a href="#">Section 2.0, "Typical Performance Curves" (2)</a>			LSb		Code = 3FFh, VRxB:VRxA = '10' Gx = '0', $V_{REF} = 2.048\text{V}$ , No Load
		See <a href="#">Section 2.0, "Typical Performance Curves" (2)</a>			LSb		Code = 3FFh, VRxB:VRxA = '01' Gx = '0', $V_{REF} = 2.048\text{V}$ , No Load
		See <a href="#">Section 2.0, "Typical Performance Curves" (2)</a>			LSb		Code = 3FFh, VRxB:VRxA = '00' No Load
		—	—	70	LSb	12-bit	Code = FFFh, VRxB:VRxA = '11' Gx = '0', $V_{REF} = 2.048\text{V}$ , No Load
		See <a href="#">Section 2.0, "Typical Performance Curves" (2)</a>			LSb		Code = FFFh, VRxB:VRxA = '10' Gx = '0', $V_{REF} = 2.048\text{V}$ , No Load
		See <a href="#">Section 2.0, "Typical Performance Curves" (2)</a>			LSb		Code = FFFh, VRxB:VRxA = '01' Gx = '0', $V_{REF} = 2.048\text{V}$ , No Load
		See <a href="#">Section 2.0, "Typical Performance Curves" (2)</a>			LSb		Code = FFFh, VRxB:VRxA = '00' No Load

**Note 2** This parameter is ensured by characterization.

## DC CHARACTERISTICS (CONTINUED)

DC Characteristics		Standard Operating Conditions (unless otherwise specified):					
		Operating Temperature: $-40^{\circ}\text{C} \leq T_A \leq +125^{\circ}\text{C}$ (Extended) Unless otherwise noted, all parameters apply across these specified operating ranges: $V_{DD} = +2.7\text{V to } 5.5\text{V}$ , $V_{REF} = +2.048\text{V to } V_{DD}$ , $V_{SS} = 0\text{V}$ $G_x = '0'$ , $R_L = 5\text{ k}\Omega$ from $V_{OUT}$ to GND, $C_L = 100\text{ pF}$ Typical specifications represent values for $V_{DD} = 5.5\text{V}$ , $T_A = +25^{\circ}\text{C}$ .					
Parameters	Sym.	Min.	Typ.	Max.	Units	Conditions	
Gain Error (see B.9 "Gain Error ( $E_G$ )") <sup>(8)</sup>	$E_G$	-1.0	$\pm 0.1$	+1.0	% of FSR	8-bit	Code = 250, No Load VRxB:VRxA = '00' Gx = '0'
		-1.0	$\pm 0.1$	+1.0	% of FSR	10-bit	Code = 1000, No Load VRxB:VRxA = '00' Gx = '0'
		-1.0	$\pm 0.1$	+1.0	% of FSR	12-bit	Code = 4000, No Load VRxB:VRxA = '00' Gx = '0'
Gain-Error Drift (see B.10 "Gain-Error Drift ( $E_{GD}$ )")	$\Delta G/^{\circ}\text{C}$	—	-3	—	ppm/ $^{\circ}\text{C}$		

**Note 8** This gain error does not include offset error.

# MCP48FVBXX

## DC CHARACTERISTICS (CONTINUED)

Parameters	Sym.	Min.	Typ.	Max.	Units	Conditions	
<b>Standard Operating Conditions (unless otherwise specified):</b> Operating Temperature: $-40^{\circ}\text{C} \leq T_A \leq +125^{\circ}\text{C}$ (Extended) Unless otherwise noted, all parameters apply across these specified operating ranges: $V_{DD} = +2.7\text{V}$ to $5.5\text{V}$ , $V_{REF} = +2.048\text{V}$ to $V_{DD}$ , $V_{SS} = 0\text{V}$ $G_x = '0'$ , $R_L = 5\text{ k}\Omega$ from $V_{OUT}$ to GND, $C_L = 100\text{ pF}$ Typical specifications represent values for $V_{DD} = 5.5\text{V}$ , $T_A = +25^{\circ}\text{C}$ .							
Integral Nonlinearity (see B.11 "Integral Nonlinearity (INL)") (10)	INL	-0.5	$\pm 0.1$	+0.5	LSb	8-bit	VRxB:VRxA = '10' (codes: 6 to 250) $V_{DD} = V_{REF} = 5.5\text{V}$
		See Section 2.0, "Typical Performance Curves" (2)			LSb		VRxB:VRxA = '00', '01', '11'
		See Section 2.0, "Typical Performance Curves" (2)			LSb		VRxB:VRxA = '01' $V_{DD} = 5.5\text{V}$ , $G_x = '1'$
		See Section 2.0, "Typical Performance Curves" (2)			LSb		VRxB:VRxA = '10', '11' $V_{REF} = 1.0\text{V}$ , $G_x = '1'$
		See Section 2.0, "Typical Performance Curves" (2)			LSb		$V_{DD} = 1.8\text{V}$ $V_{REF} = 1.0\text{V}$
		-1.5	$\pm 0.4$	+1.5	LSb	10-bit	VRxB:VRxA = '10' (codes: 25 to 1000) $V_{DD} = V_{REF} = 5.5\text{V}$
		See Section 2.0, "Typical Performance Curves" (2)			LSb		VRxB:VRxA = '00', '01', '11'
		See Section 2.0, "Typical Performance Curves" (2)			LSb		VRxB:VRxA = '01' $V_{DD} = 5.5\text{V}$ , $G_x = '1'$
		See Section 2.0, "Typical Performance Curves" (2)			LSb		VRxB:VRxA = '10', '11' $V_{REF} = 1.0\text{V}$ , $G_x = '1'$
		See Section 2.0, "Typical Performance Curves" (2)			LSb		$V_{DD} = 1.8\text{V}$ $V_{REF} = 1.0\text{V}$
		-6	$\pm 1.5$	+6	LSb	12-bit	VRxB:VRxA = '10' (codes: 100 to 4000) $V_{DD} = V_{REF} = 5.5\text{V}$ .
		See Section 2.0, "Typical Performance Curves" (2)			LSb		VRxB:VRxA = '00', '01', '11'
		See Section 2.0, "Typical Performance Curves" (2)			LSb		VRxB:VRxA = '01' $V_{DD} = 5.5\text{V}$ , $G_x = '1'$
		See Section 2.0, "Typical Performance Curves" (2)			LSb		VRxB:VRxA = '10', '11' $V_{REF} = 1.0\text{V}$ , $G_x = '1'$
		See Section 2.0, "Typical Performance Curves" (2)			LSb		$V_{DD} = 1.8\text{V}$ $V_{REF} = 1.0\text{V}$

**Note 2** This parameter is ensured by characterization.

**Note 10** Code range dependent on resolution: 8-bit, codes 6 to 250; 10-bit, codes 25 to 1000; 12-bit, codes 100 to 4000.

## DC CHARACTERISTICS (CONTINUED)

Parameters	Sym.	Min.	Typ.	Max.	Units	Conditions			
Differential Nonlinearity (see <a href="#">B.12 “Differential Nonlinearity (DNL)”</a> <sup>(10)</sup> )	DNL	<b>Standard Operating Conditions (unless otherwise specified):</b> Operating Temperature: $-40^{\circ}\text{C} \leq T_A \leq +125^{\circ}\text{C}$ (Extended) Unless otherwise noted, all parameters apply across these specified operating ranges: $V_{DD} = +2.7\text{V}$ to $5.5\text{V}$ , $V_{REF} = +2.048\text{V}$ to $V_{DD}$ , $V_{SS} = 0\text{V}$ $G_x = '0'$ , $R_L = 5\text{ k}\Omega$ from $V_{OUT}$ to GND, $C_L = 100\text{ pF}$ Typical specifications represent values for $V_{DD} = 5.5\text{V}$ , $T_A = +25^{\circ}\text{C}$ .							
		-0.25	$\pm 0.0125$	+0.25	LSb	8-bit	VRxB:VRxA = '10' (codes: 6 to 250) $V_{DD} = V_{REF} = 5.5\text{V}$		
		See <a href="#">Section 2.0, “Typical Performance Curves”</a> (2)			LSb		VRxB:VRxA = '00', '01', '11'		
		See <a href="#">Section 2.0, “Typical Performance Curves”</a> (2)			LSb		VRxB:VRxA = '01' $V_{DD} = 5.5\text{V}$ , $G_x = '1'$		
		See <a href="#">Section 2.0, “Typical Performance Curves”</a> (2)			LSb		VRxB:VRxA = '10', '11' $V_{REF} = 1.0\text{V}$ , $G_x = '1'$		
		See <a href="#">Section 2.0, “Typical Performance Curves”</a> (2)			LSb		$V_{DD} = 1.8\text{V}$		
		-0.5	$\pm 0.05$	+0.5	LSb	10-bit	VRxB:VRxA = '10' (codes: 25 to 1000) $V_{DD} = V_{REF} = 5.5\text{V}$		
		See <a href="#">Section 2.0, “Typical Performance Curves”</a> (2)			LSb		VRxB:VRxA = '00', '01', '11'		
		See <a href="#">Section 2.0, “Typical Performance Curves”</a> (2)			LSb		VRxB:VRxA = '01' $V_{DD} = 5.5\text{V}$ , $G_x = '1'$		
		See <a href="#">Section 2.0, “Typical Performance Curves”</a> (2)			LSb		VRxB:VRxA = '10', '11' $V_{REF} = 1.0\text{V}$ , $G_x = '1'$		
		See <a href="#">Section 2.0, “Typical Performance Curves”</a> (2)			LSb		$V_{DD} = 1.8\text{V}$		
		-1.0	$\pm 0.2$	+1.0	LSb	12-bit	VRxB:VRxA = '10' (codes: 100 to 4000) $V_{DD} = V_{REF} = 5.5\text{V}$		
		See <a href="#">Section 2.0, “Typical Performance Curves”</a> (2)			LSb		VRxB:VRxA = '00', '01', '11'		
		See <a href="#">Section 2.0, “Typical Performance Curves”</a> (2)			LSb		VRxB:VRxA = '01' $V_{DD} = 5.5\text{V}$ , $G_x = '1'$		
		See <a href="#">Section 2.0, “Typical Performance Curves”</a> (2)			LSb		VRxB:VRxA = '10', '11' $V_{REF} = 1.0\text{V}$ , $G_x = '1'$		
		See <a href="#">Section 2.0, “Typical Performance Curves”</a> (2)			LSb		$V_{DD} = 1.8\text{V}$		

**Note 2** This parameter is ensured by characterization.

**Note 10** Code range dependent on resolution: 8-bit, codes 6 to 250; 10-bit, codes 25 to 1000; 12-bit, codes 100 to 4000.

# MCP48FVBXX

## DC CHARACTERISTICS (CONTINUED)

Parameters	Sym.	Min.	Typ.	Max.	Units	Conditions
-3 dB Bandwidth (see B.16 “-3 dB Bandwidth”)	BW	—	200	—	kHz	$V_{REF} = 2.048\text{V} \pm 0.1\text{V}$ $VRxB:VRxA = '10'$ , $G_x = '0'$
		—	100	—	kHz	$V_{REF} = 2.048\text{V} \pm 0.1\text{V}$ $VRxB:VRxA = '10'$ , $G_x = '1'$
<b>Output Amplifier</b>						
Minimum Output Voltage	$V_{OUT(MIN)}$	—	0.01	—	V	$1.8\text{V} \leq V_{DD} < 5.5\text{V}$ Output Amplifier's minimum drive
Maximum Output Voltage	$V_{OUT(MAX)}$	—	$V_{DD} - 0.04$	—	V	$1.8\text{V} \leq V_{DD} < 5.5\text{V}$ Output Amplifier's maximum drive
Phase Margin	PM	—	66	—	Degree (°)	$C_L = 400\text{ pF}$ $R_L = \infty$
Slew Rate (9)	SR	—	0.44	—	V/ $\mu\text{s}$	$R_L = 5\text{ k}\Omega$
Short-Circuit Current	$I_{SC}$	3	9	14	mA	DAC code = Full Scale
<b>Internal Band Gap</b>						
Band Gap Voltage	$V_{BG}$	1.18	1.22	1.26	V	
Band Gap Voltage Temperature Coefficient	$V_{BGTC}$	—	15	—	ppm/ $^{\circ}\text{C}$	
Operating Range ( $V_{DD}$ )		2.0	—	5.5	V	$V_{REF}$ pin voltage stable
		2.2	—	5.5	V	$V_{OUT}$ output linear
<b>External Reference (<math>V_{REF}</math>)</b>						
Input Range (1)	$V_{REF}$	$V_{SS}$	—	$V_{DD} - 0.04$	V	$VRxB:VRxA = '11'$ (Buffered mode)
		$V_{SS}$	—	$V_{DD}$	V	$VRxB:VRxA = '10'$ (Unbuffered mode)
Input Capacitance	$C_{REF}$	—	1	—	pF	$VRxB:VRxA = '10'$ (Unbuffered mode)
Total Harmonic Distortion (1)	THD	—	-64	—	dB	$V_{REF} = 2.048\text{V} \pm 0.1\text{V}$ $VRxB:VRxA = '10'$ , $G_x = '0'$ Frequency = 1 kHz
<b>Dynamic Performance</b>						
Major Code Transition Glitch (see B.14 “Major-Code Transition Glitch”)		—	45	—	nV-s	1 LSb change around major carry 7FFh to 800h for 12-bit devices 1FFh to 200h for 10-bit devices 7Fh to 80h for 8-bit devices
Digital Feedthrough (see B.15 “Digital Feedthrough”)		—	<10	—	nV-s	

**Note 1** This parameter is ensured by design.

**Note 9** Within 1/2 LSb of final value when code changes from 1/4 to 3/4 of FSR. (Example: 400h to C00h in 12-bit device).

## DC CHARACTERISTICS (CONTINUED)

Parameters	Sym.	Min.	Typ.	Max.	Units	Conditions
<b>Standard Operating Conditions (unless otherwise specified):</b> Operating Temperature: $-40^{\circ}\text{C} \leq T_A \leq +125^{\circ}\text{C}$ (Extended) Unless otherwise noted, all parameters apply across these specified operating ranges: $V_{DD} = +2.7\text{V}$ to $5.5\text{V}$ , $V_{REF} = +2.048\text{V}$ to $V_{DD}$ , $V_{SS} = 0\text{V}$ $G_x = '0'$ , $R_L = 5\text{ k}\Omega$ from $V_{OUT}$ to GND, $C_L = 100\text{ pF}$ Typical specifications represent values for $V_{DD} = 5.5\text{V}$ , $T_A = +25^{\circ}\text{C}$ .						
Digital Inputs/Outputs (CS, SCK, SDI, SDO, LAT0/HVC)						
Schmitt Trigger High-Input Threshold	$V_{IH}$	$0.45 V_{DD}$	—	—	V	$2.7\text{V} \leq V_{DD} \leq 5.5\text{V}$
		$0.5 V_{DD}$	—	—	V	$1.8\text{V} \leq V_{DD} \leq 2.7\text{V}$
Schmitt Trigger Low-Input Threshold	$V_{IL}$	—	—	$0.2 V_{DD}$	V	
Hysteresis of Schmitt Trigger Inputs	$V_{HYS}$	—	$0.1 V_{DD}$	—	V	
Output Low Voltage	$V_{OL}$	$V_{SS}$	—	$0.3 V_{DD}$	V	$I_{OL} = 5\text{ mA}$ , $V_{DD} = 5.5\text{V}$
		$V_{SS}$	—	$0.3 V_{DD}$	V	$I_{OL} = 1\text{ mA}$ , $V_{DD} = 1.8\text{V}$
Output High Voltage	$V_{OH}$	$0.7V_{DD}$	—	$V_{DD}$	V	$I_{OH} = -2.5\text{ mA}$ , $V_{DD} = 5.5\text{V}$
		$0.7V_{DD}$	—	$V_{DD}$	V	$I_{OH} = -1\text{ mA}$ , $V_{DD} = 1.8\text{V}$
Input Leakage Current	$I_{IL}$	-1	—	1	$\mu\text{A}$	$V_{IN} = V_{DD}$ and $V_{IN} = V_{SS}$
Pin Capacitance	$C_{IN}$ , $C_{OUT}$	—	10	—	pF	$f_C = 20\text{ MHz}$

# MCP48FVBXX

## DC CHARACTERISTICS (CONTINUED)

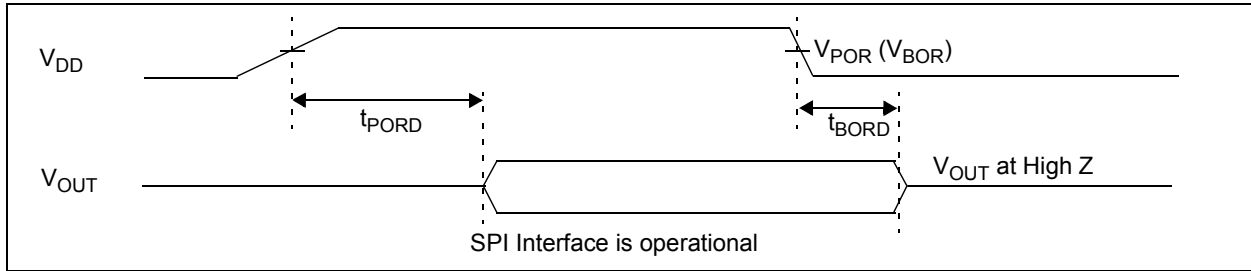
Parameters	Sym.	Min.	Typ.	Max.	Units	Conditions	
<b>DC Characteristics</b>							
<b>Standard Operating Conditions (unless otherwise specified):</b> Operating Temperature: $-40^{\circ}\text{C} \leq T_A \leq +125^{\circ}\text{C}$ (Extended) Unless otherwise noted, all parameters apply across these specified operating ranges: $V_{DD} = +2.7\text{V}$ to $5.5\text{V}$ , $V_{REF} = +2.048\text{V}$ to $V_{DD}$ , $V_{SS} = 0\text{V}$ $G_x = '0'$ , $R_L = 5\text{ k}\Omega$ from $V_{OUT}$ to GND, $C_L = 100\text{ pF}$ Typical specifications represent values for $V_{DD} = 5.5\text{V}$ , $T_A = +25^{\circ}\text{C}$ .							
<b>RAM Value</b>							
Value Range	N	0h	—	FFh	hex	8-bit	
		0h	—	3FFh	hex	10-bit	
		0h	—	FFFh	hex	12-bit	
DAC Register POR/BOR Value	N	See <a href="#">Table 4-2</a>			hex	8-bit	
		See <a href="#">Table 4-2</a>			hex	10-bit	
		See <a href="#">Table 4-2</a>			hex	12-bit	
PDCON Initial Factory Setting		See <a href="#">Table 4-2</a>			hex		
<b>Power Requirements</b>							
Power Supply Sensitivity (see <a href="#">B.17 "Power-Supply Sensitivity (PSS)"</a> )	PSS	—	0.002	0.005	%/%	8-bit	Code = 7Fh
		—	0.002	0.005	%/%	10-bit	Code = 1FFh
		—	0.002	0.005	%/%	12-bit	Code = 7FFh

## DC Notes:

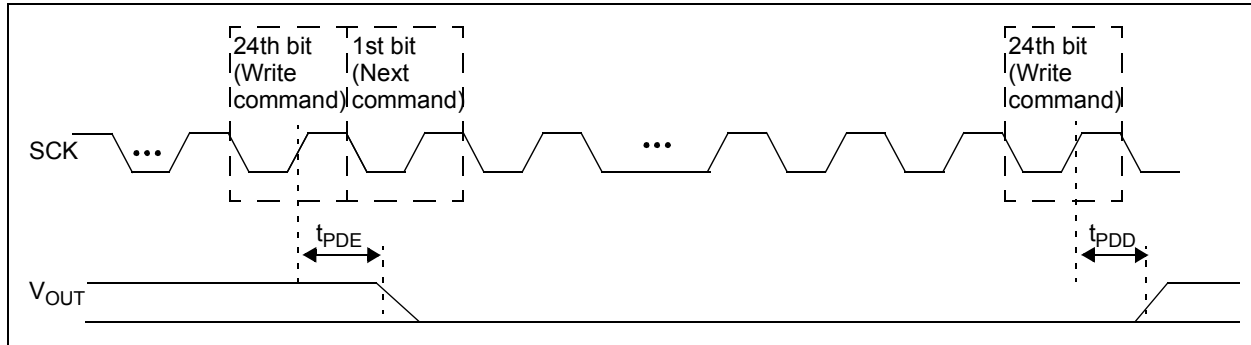
1. This parameter is ensured by design.
2. This parameter is ensured by characterization.
3. POR/BOR voltage trip point is not slope dependent. Hysteresis implemented with time delay.
4. Supply current is independent of current through the resistor ladder in mode VRxB:VRxA = '10'.
5. The PDxB:PDxA = '01', '10', and '11' configurations should have the same current.
6. By design, this is the worst-case current mode.
7. Resistance is defined as the resistance between the VREF pin (mode VRxB:VRxA = '10') to VSS pin. For dual-channel devices (MCP48FVBX2), this is the effective resistance of the each resistor ladder. The resistance measurement is that of the two resistor ladders measured in parallel.
8. This gain error does not include offset error.
9. Within 1/2 LSb of final value when code changes from 1/4 to 3/4 of FSR. (Example: 400h to C00h in 12-bit device).
10. Code range dependent on resolution: 8-bit, codes 6 to 250; 10-bit, codes 25 to 1000; 12-bit, codes 100 to 4000.
11. Variation of one output voltage to mean output voltage.

# MCP48FVBXX

## 1.1 Reset, Power-Down, and SPI Mode Timing Waveforms and Requirements



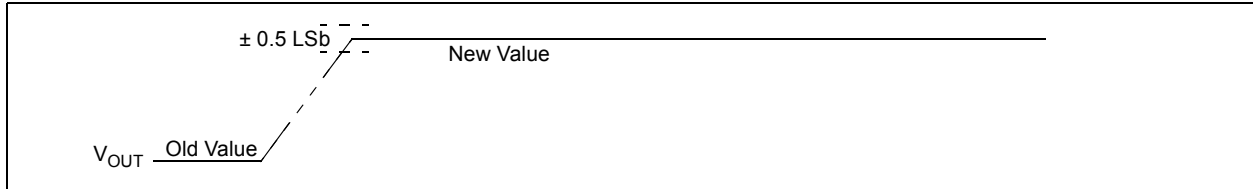
**FIGURE 1-1:** Power-on and Brown-out Reset Waveforms.



**FIGURE 1-2:** SPI Power-Down Command Waveforms.

**TABLE 1-1: RESET AND POWER-DOWN TIMING**

Parameters	Standard Operating Conditions (unless otherwise specified): Operating Temperature: $-40^{\circ}\text{C} \leq T_A \leq +125^{\circ}\text{C}$ (Extended) Unless otherwise noted, all parameters apply across these specified operating ranges: $V_{DD} = +1.8\text{V to } 5.5\text{V}$ , $V_{SS} = 0\text{V}$ $R_L = 5\text{ k}\Omega$ from $V_{OUT}$ to $V_{SS}$ , $C_L = 100\text{ pF}$ Typical specifications represent values for $V_{DD} = 5.5\text{V}$ , $T_A = +25^{\circ}\text{C}$ .					Conditions
	Sym.	Min.	Typ.	Max.	Units	
Power-on Reset Delay	$t_{PORD}$	—	60	—	$\mu\text{s}$	
Brown-out Reset Delay	$t_{BORD}$	—	45	—	$\mu\text{s}$	$V_{DD}$ transitions from $V_{DD(MIN)} \rightarrow > V_{POR}$ $V_{OUT}$ driven to $V_{OUT}$ disabled
Power-Down Output Disable Time Delay	$T_{PDD}$	—	10.5	—	$\mu\text{s}$	$\text{PDxB:PDxA} = '11', '10', \text{ or } '01' \rightarrow '00'$ started from falling edge of the SCK at the end of the 24th clock cycle. Volatile DAC Register = FFh, $V_{OUT} = 10\text{ mV}$ $V_{OUT}$ not connected
Power-Down Output Enable Time Delay	$T_{PDE}$	—	1	—	$\mu\text{s}$	$\text{PDxB:PDxA} = '00' \rightarrow '11', '10', \text{ or } '01'$ started from falling edge of the SCK at the end of the 24th clock cycle $V_{OUT} = V_{OUT} - 10\text{ mV}$ . $V_{OUT}$ not connected



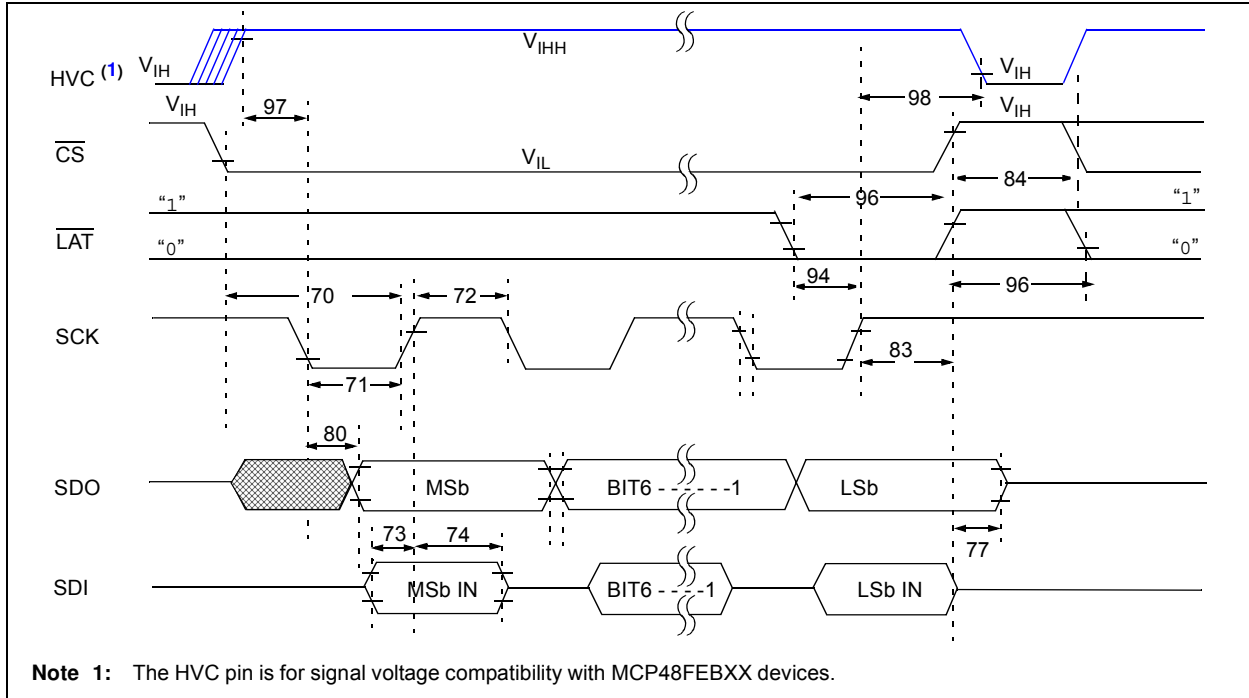
**FIGURE 1-3:**  $V_{OUT}$  Settling Time Waveform.

**TABLE 1-2:  $V_{OUT}$  SETTling TIMING**

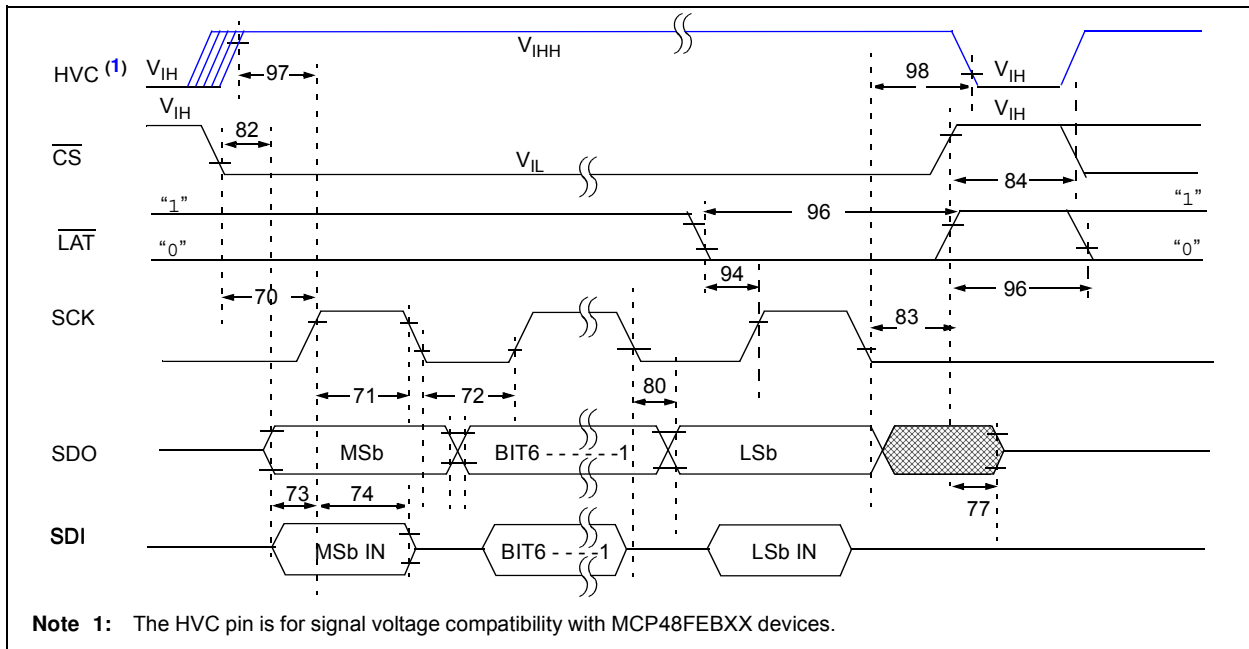
Parameters	Sym.	Min.	Typ.	Max.	Units	Conditions	
						8-bit	10-bit
$V_{OUT}$ Settling Time ( $\pm 0.5\text{LSb}$ error band, $C_L = 100\text{ pF}$ ) (see B.13 “Settling Time”)	$t_s$	—	7.8	—	$\mu\text{s}$	8-bit	Code = 40h $\rightarrow$ C0h; C0h $\rightarrow$ 40h <sup>(3)</sup>
		—	7.8	—	$\mu\text{s}$	10-bit	Code = 100h $\rightarrow$ 300h; 300h $\rightarrow$ 100h <sup>(3)</sup>
		—	7.8	—	$\mu\text{s}$	12-bit	Code = 400h $\rightarrow$ C00h; C00h $\rightarrow$ 400h <sup>(3)</sup>

**Note 3** Within 1/2 LSB of final value when code changes from 1/4 to 3/4 of FSR. (Example: 400h to C00h in 12-bit device).

# MCP48FVBXX



**FIGURE 1-4:** SPI Timing (Mode = 11) Waveforms.



**FIGURE 1-5:** SPI Timing (Mode = 00) Waveforms.

**TABLE 1-3: SPI REQUIREMENTS (MODE = 11)**

SPI AC Characteristics		Standard Operating Conditions (unless otherwise specified): Operating Temperature: $-40^{\circ}\text{C} \leq T_A \leq +125^{\circ}\text{C}$ (Extended) Operating Voltage range is described in <a href="#">DC Characteristics</a> .				
Param. No.	Sym.	Characteristic	Min.	Max.	Units	Conditions
	$F_{\text{SCK}}$	SCK input frequency	—	10	MHz	$V_{\text{DD}} = 2.7\text{V to } 5.5\text{V}$ (Read command)
			—	20	MHz	$V_{\text{DD}} = 2.7\text{V to } 5.5\text{V}$ (All other commands)
			—	1	MHz	$V_{\text{DD}} = 1.8\text{V to } 2.7\text{V}$
70	TcsA2sch	$\overline{\text{CS}}$ Active ( $V_{\text{IL}}$ ) to command's 1st SCK $\uparrow$ input	60	—	ns	
71	Tsch	SCK input high time	20	—	ns	$V_{\text{DD}} = 2.7\text{V to } 5.5\text{V}$
			400	—	ns	$V_{\text{DD}} = 1.8\text{V to } 2.7\text{V}$
72	TscL	SCK input low time	20	—	ns	$V_{\text{DD}} = 2.7\text{V to } 5.5\text{V}$
			400	—	ns	$V_{\text{DD}} = 1.8\text{V to } 2.7\text{V}$
73	TdiV2sch	Setup time of SDI input to SCK $\uparrow$ edge	10	—	ns	
74	Tsch2diL	Hold time of SDI input from SCK $\uparrow$ edge	20	—	ns	
77	TcsH2doZ	$\overline{\text{CS}}$ Inactive ( $V_{\text{IH}}$ ) to SDO output hi-impedance	—	50	ns	<a href="#">Note 1</a>
80	TscL2doV	SDO data output valid after SCK $\downarrow$ edge	—	45	ns	$V_{\text{DD}} = 2.7\text{V to } 5.5\text{V}$
			—	170	ns	$V_{\text{DD}} = 1.8\text{V to } 2.7\text{V}$
83	Tsch2csL	$\overline{\text{CS}}$ Inactive ( $V_{\text{IH}}$ ) after SCK $\uparrow$ edge	100	—	ns	$V_{\text{DD}} = 2.7\text{V to } 5.5\text{V}$
			1	—	$\mu\text{s}$	$V_{\text{DD}} = 1.8\text{V to } 2.7\text{V}$
84	TcsH	$\overline{\text{CS}}$ high time ( $V_{\text{IH}}$ )	50	—	ns	
94	$T_{\text{LATSU}}$	$\overline{\text{LAT}} \downarrow$ to SCK $\uparrow$ (write data 24th bit) setup time	20	—	ns	Write Data transferred <sup>(4)</sup>
96	$T_{\text{LAT}}$	$\overline{\text{LAT}}$ high or low time	20	—	ns	
97	$T_{\text{HVCSU}}$	HVC $\uparrow$ to SCK $\downarrow$ (1st data bit) (HVC setup time)	0	—	ns	High-Voltage Commands <sup>(1)</sup> (MCP48FEBxx only)
98	$T_{\text{HVCHD}}$	SCK $\uparrow$ (last bit of command (8th or 24th bit)) to HVC $\downarrow$ (HVC hold time)	25	—	ns	High-Voltage Commands <sup>(1)</sup> (MCP48FEBxx only)

**Note 1** This parameter is ensured by design.

**Note 4** The transition of the LAT signal must occur 10 ns before the rising edge of the 24th SCK signal (Spec 94) or the current register data value may not be transferred to the output latch ( $V_{\text{OUT}}$ ) before the register is overwritten with the new value.

# MCP48FVBXX

TABLE 1-4: SPI REQUIREMENTS (MODE = 00)

SPI AC Characteristics		Standard Operating Conditions (unless otherwise specified): Operating Temperature: $-40^{\circ}\text{C} \leq T_A \leq +125^{\circ}\text{C}$ (Extended) Operating Voltage range is described in <a href="#">DC Characteristics</a> .				
Param. No.	Sym.	Characteristic	Min.	Max.	Units	Conditions
	F <sub>SCK</sub>	SCK input frequency	—	10	MHz	V <sub>DD</sub> = 2.7V to 5.5V (Read command)
			—	20	MHz	V <sub>DD</sub> = 2.7V to 5.5V (All other commands)
			—	1	MHz	V <sub>DD</sub> = 1.8V to 2.7V
70	TcsA2sch	$\overline{\text{CS}}$ Active (V <sub>IL</sub> ) to SCK $\uparrow$ input	60	—	ns	
71	Tsch	SCK input high time	20	—	ns	V <sub>DD</sub> = 2.7V to 5.5V
			400	—	ns	V <sub>DD</sub> = 1.8V to 2.7V
72	TscL	SCK input low time	20	—	ns	V <sub>DD</sub> = 2.7V to 5.5V
			400	—	ns	V <sub>DD</sub> = 1.8V to 2.7V
73	TdIV2sch	Setup time of SDI input to SCK $\uparrow$ edge	10	—	ns	
74	Tsch2dIL	Hold time of SDI input from SCK $\uparrow$ edge	20	—	ns	
77	TcsH2doZ	$\overline{\text{CS}}$ Inactive (V <sub>IH</sub> ) to SDO output hi-impedance	—	50	ns	<a href="#">Note 1</a>
80	TscL2doV	SDO data output valid after SCK $\downarrow$ edge	—	45	ns	V <sub>DD</sub> = 2.7V to 5.5V
			—	170	ns	V <sub>DD</sub> = 1.8V to 2.7V
82	TssL2doV	SDO data output valid after $\overline{\text{CS}}$ Active (V <sub>IL</sub> )	—	70	ns	
83	Tsch2csl	$\overline{\text{CS}}$ Inactive (V <sub>IH</sub> ) after SCK $\downarrow$ edge	100	—	ns	V <sub>DD</sub> = 2.7V to 5.5V
			1		$\mu\text{s}$	V <sub>DD</sub> = 1.8V to 2.7V
84	TcsH	$\overline{\text{CS}}$ high time (V <sub>IH</sub> )	50	—	ns	
94	T <sub>LATSU</sub>	$\overline{\text{LAT}} \downarrow$ to SCK $\uparrow$ (write data 24th bit) setup time	10	—	ns	Write Data transferred <sup>(4)</sup>
96	T <sub>LAT</sub>	$\overline{\text{LAT}}$ high or low time	50	—	ns	
97	T <sub>HVCSU</sub>	HVC $\uparrow$ to SCK $\uparrow$ (1st data bit) (HVC setup time)	0	—	ns	High-Voltage Commands <sup>(1)</sup> (MCP48FEBXX only)
98	T <sub>HVCHD</sub>	SCK $\downarrow$ (last bit of command (8th or 24th bit)) to HVC $\downarrow$ (HVC hold time)	25	—	ns	High-Voltage Commands <sup>(1)</sup> (MCP48FEBXX only)

**Note 1** This parameter is ensured by design.

**Note 4** The transition of the LAT signal must occur 10 ns before the rising edge of the 24th SCK signal (Spec 94) or the current register data value may not be transferred to the output latch (V<sub>OUT</sub>) before the register is overwritten with the new value.

## Timing Table Notes:

1. This parameter is ensured by design.
2. This parameter ensured by characterization.
3. Within 1/2 LSB of final value when code changes from 1/4 to 3/4 of FSR. (Example: 400h to C00h in 12-bit device).
4. The transition of the  $\overline{\text{LAT}}$  signal must occur 10 ns before the rising edge of the 24th SCK signal (Spec 94) or the current register data value may not be transferred to the output latch ( $V_{\text{OUT}}$ ) before the register is overwritten with the new value.

# MCP48FVBXX

## Temperature Specifications

Electrical Specifications: Unless otherwise indicated, $V_{DD} = +2.7V$ to $+5.5V$ , $V_{SS} = GND$ .						
Parameters	Sym.	Min.	Typ.	Max.	Units	Conditions
<b>Temperature Ranges</b>						
Specified Temperature Range	$T_A$	-40	—	+125	°C	
Operating Temperature Range	$T_A$	-40	—	+125	°C	Note 1
Storage Temperature Range	$T_A$	-65	—	+150	°C	
<b>Thermal Package Resistances</b>						
Thermal Resistance, 10LD-MSOP	$\theta_{JA}$	—	202	—	°C/W	

**Note 1:** The MCP48FVBXX devices operate over this extended temperature range, but with reduced performance. Operation in this range must not cause  $T_J$  to exceed the Maximum Junction Temperature of  $+150^\circ\text{C}$ .

## 2.0 TYPICAL PERFORMANCE CURVES

**Note:** The device Performance Curves are available in a separate document. This is done to keep the file size of this PDF document less than the 10 MB file attachment limit of many mail servers.  
The MCP48FVBXX Performance Curves document is literature number **DS20005440**, and can be found on the Microchip website. Look on the MCP48FVBXX product page under “Documentation and Software”, in the Data Sheets category.

# MCP48FVBXX

---

NOTES:

## 3.0 PIN DESCRIPTIONS

Overviews of the pin functions are provided in [Sections 3.1, “Positive Power Supply Input \(VDD\)”](#) through [3.10, “SPI - Serial Clock Pin \(SCK\)”](#). The descriptions of the pins for the single-DAC output device are listed in [Table 3-1](#), and descriptions for the dual-DAC output device are listed in [Table 3-2](#).

**TABLE 3-1: MCP48FVBX1 (SINGLE-DAC) PINOUT DESCRIPTION**

Pin				Standard Function
MSOP-10LD	Symbol	I/O	Buffer Type	
1	V <sub>DD</sub>	—	P	Supply Voltage Pin
2	$\overline{CS}$	I	ST	SPI Chip Select Pin
3	V <sub>REF0</sub>	A	Analog	Voltage Reference Input Pin
4	V <sub>OUT0</sub>	A	Analog	Buffered Analog Voltage Output Pin
5	NC	—	—	Not Internally Connected
6	LAT0/HVC	I	HV ST	DAC Register Latch/High-Voltage Command Pin. Latch Pin allows the value in the Serial Shift Register to transfer to the volatile DAC register. (The HVC signal is present to indicate voltage level compatibility with the nonvolatile device family (MCP48FEBXX)).
7	V <sub>SS</sub>	—	P	Ground Reference Pin for all circuitries on the device
8	SDO	O	—	SPI Serial Data Output Pin
9	SCK	I	ST	SPI Serial Clock Pin
10	SDI	I	ST	SPI Serial Data Input Pin

**Legend:** A = Analog      ST = Schmitt Trigger      HV = High Voltage  
 I = Input                  O = Output                  I/O = Input/Output                  P = Power

**TABLE 3-2: MCP48FVBX2 (DUAL-DAC) PINOUT DESCRIPTION**

Pin				Standard Function
MSOP-10LD	Symbol	I/O	Buffer Type	
1	V <sub>DD</sub>	—	P	Supply Voltage Pin
2	$\overline{CS}$	I	ST	SPI Chip Select Pin
3	V <sub>REF</sub>	A	Analog	Voltage Reference Input Pin (for DAC0 and DAC1)
4	V <sub>OUT0</sub>	A	Analog	Buffered Analog Voltage Output 0 Pin
5	V <sub>OUT1</sub>	A	Analog	Buffered Analog Voltage Output 1 Pin
6	LAT/HVC	I	HV ST	DAC Register Latch/High-Voltage Command Pin. Latch Pin allows the value in the Serial Shift Register to transfer to the volatile DAC register (for DAC0 and DAC1). (The HVC signal is present to indicate voltage level compatibility with the nonvolatile device family (MCP48FEBXX)).
7	V <sub>SS</sub>	—	P	Ground Reference Pin for all circuitries on the device
8	SDO	O	—	SPI Serial Data Output Pin
9	SCK	I	ST	SPI Serial Clock Pin
10	SDI	I	ST	SPI Serial Data Input Pin

**Legend:** A = Analog      ST = Schmitt Trigger      HV = High Voltage  
 I = Input                  O = Output                  I/O = Input/Output                  P = Power

# MCP48FVBXX

## 3.1 Positive Power Supply Input ( $V_{DD}$ )

$V_{DD}$  is the positive supply voltage input pin. The input supply voltage is relative to  $V_{SS}$ .

The power supply at the  $V_{DD}$  pin should be as clean as possible for a good DAC performance. It is recommended to use an appropriate bypass capacitor of about 0.1  $\mu\text{F}$  (ceramic) to ground. An additional 10  $\mu\text{F}$  capacitor (tantalum) in parallel is also recommended to further attenuate noise present in application boards.

## 3.2 Voltage Reference Pin ( $V_{REF}$ )

The  $V_{REF}$  pin is either an input or an output. When the DAC's voltage reference is configured as the  $V_{REF}$  pin, the pin is an input. When the DAC's voltage reference is configured as the internal band gap, the pin is an output.

When the DAC's voltage reference is configured as the  $V_{REF}$  pin, there are two options for this voltage input:

- $V_{REF}$  pin voltage buffered
- $V_{REF}$  pin voltage unbuffered

The buffered option is offered in cases where the external reference voltage does not have sufficient current capability to not drop its voltage when connected to the internal resistor ladder circuit.

When the DAC's voltage reference is configured as the device  $V_{DD}$ , the  $V_{REF}$  pin is disconnected from the internal circuit.

When the DAC's voltage reference is configured as the internal band gap, the  $V_{REF}$  pin's drive capability is minimal, so the output signal should be buffered.

See [Section 5.2, "Voltage Reference Selection"](#) and [Register 4-2](#) for more details on the configuration bits.

## 3.3 Analog Output Voltage Pin ( $V_{OUT}$ )

$V_{OUT}$  is the DAC analog voltage output pin. The DAC output has an output amplifier. The DAC output range is dependent on the selection of the voltage reference source (and potential Output Gain selection). These are:

- Device  $V_{DD}$  - The full-scale range of the DAC output is from  $V_{SS}$  to approximately  $V_{DD}$ .
- $V_{REF}$  pin - The full-scale range of the DAC output is from  $V_{SS}$  to  $G * V_{RL}$ , where G is the gain selection option (1x or 2x).
- Internal Band Gap - The full-scale range of the DAC output is from  $V_{SS}$  to  $G * (2 * V_{BG})$ , where G is the gain selection option (1x or 2x).

In Normal mode, the DC impedance of the output pin is about 1 $\Omega$ . In Power-Down mode, the output pin is internally connected to a known pull-down resistor of 1 k $\Omega$ , 100 k $\Omega$ , or open. The Power-Down Selection bits settings are shown in [Register 4-3](#) and [Table 5-5](#).

## 3.4 No Connect (NC)

The NC pin is not connected to the device.

## 3.5 Ground ( $V_{SS}$ )

The  $V_{SS}$  pin is the device ground reference.

The user must connect the  $V_{SS}$  pin to a ground plane through a low-impedance connection. If an analog ground path is available in the application PCB (printed circuit board), it is highly recommended that the  $V_{SS}$  pin be tied to the analog ground path or isolated within an analog ground plane of the circuit board.

## 3.6 Latch Pin ( $\overline{\text{LAT}}$ )/High-Voltage Command (HVC)

The  $\overline{\text{LAT}}$  pin is used to force the transfer of the DAC register's shift register to the DAC output register. This allows DAC outputs to be updated at the same time.

The update of the VRxB:VRxA, PDxB:PDxA and Gx bits are also controlled by the  $\overline{\text{LAT}}$  pin state.

The pin is compatible with HVC voltage levels that are used for the nonvolatile MCP48FEBXX devices.

## 3.7 SPI - Chip Select Pin ( $\overline{\text{CS}}$ )

The  $\overline{\text{CS}}$  pin enables/disables the serial interface. The serial interface must be enabled for the SPI commands to be received by the device.

Refer to [Section 6.2, "SPI Serial Interface"](#) for more details of SPI Serial Interface communication.

## 3.8 SPI - Serial Data In Pin (SDI)

The SDI pin is the serial data input pin of the SPI interface. The SDI pin is used to write the DAC registers and configuration bits.

Refer to [Section 6.2, "SPI Serial Interface"](#) for more details on SPI Serial Interface communication.

## 3.9 SPI - Serial Data Out Pin (SDO)

The SDO pin is the serial data output pin of the SPI interface. The SDO pin is used to read the DAC registers and configuration bits.

Refer to [Section 6.2, "SPI Serial Interface"](#) for more details on SPI Serial Interface communication.

## 3.10 SPI - Serial Clock Pin (SCK)

The SCK pin is the serial clock pin of the SPI interface. The MCP48FVBXX SPI Interface only accepts external serial clocks.

Refer to [Section 6.2, "SPI Serial Interface"](#) for more details on SPI Serial Interface communication.

## 4.0 GENERAL DESCRIPTION

The MCP48FVBX1 (MCP48FVB01, MCP48FVB11, and MCP48FVB21) devices are single-channel voltage output devices. The MCP48FVBX2 (MCP48FVB02, MCP48FVB12, and MCP48FVB22) devices are dual-channel voltage output devices.

These devices are offered with 8-bit (MCP48FVB0X), 10-bit (MCP48FVB1X) and 12-bit (MCP48FVB2X) resolution and include volatile memory, an SPI serial interface and a write latch ( $\overline{\text{LAT}}$ ) pin to control the update of the written DAC value to the DAC output pin.

The devices use a resistor ladder architecture. The resistor ladder DAC is driven from a software-selectable voltage reference source. The source can be either the device's internal  $V_{DD}$ , an external  $V_{REF}$  pin voltage (buffered or unbuffered) or an internal band gap voltage source.

The DAC output is buffered with a low-power, precision output amplifier (op amp). This output amplifier provides a rail-to-rail output with low offset voltage and low noise. The gain (1x or 2x) of the output buffer is software configurable.

The devices operate from a single supply voltage. This voltage is specified from 2.7V to 5.5V for full specified operation, and from 1.8V to 5.5V for digital operation. The devices operate between 1.8V and 2.7V, but some device parameters are not specified.

The main functional blocks are:

- [Power-on Reset/Brown-out Reset \(POR/BOR\)](#)
- [Device Memory](#)
- [Resistor Ladder](#)
- [Output Buffer/ \$V\_{OUT}\$  Operation](#)
- [Internal Band Gap](#) (as a voltage reference)
- [SPI Serial Interface Module](#)

## 4.1 Power-on Reset/Brown-out Reset (POR/BOR)

The internal Power-on Reset (POR)/Brown-out Reset (BOR) circuit monitors the power supply voltage ( $V_{DD}$ ) during operation. This circuit ensures correct device start-up at system power-up and power-down events. The device's RAM retention voltage ( $V_{RAM}$ ) is lower than the POR/BOR voltage trip point ( $V_{POR}/V_{BOR}$ ). The maximum  $V_{POR}/V_{BOR}$  voltage is less than 1.8V.

POR occurs as the voltage is rising (typically from 0V), while BOR occurs as the voltage is falling (typically from  $V_{DD(MIN)}$  or higher).

The POR and BOR trip points are at the same voltage, and the condition is determined by whether the  $V_{DD}$  voltage is rising or falling (see [Figure 4-1](#)). What occurs is different depending on whether the reset is a POR or a BOR.

When  $V_{POR}/V_{BOR} < V_{DD} < 2.7V$ , the electrical performance may not meet the data sheet specifications. In this region, the device is capable of reading and writing to its volatile memory if the proper serial command is executed.

# MCP48FVBXX

## 4.1.1 POWER-ON RESET

The Power-on Reset is the case where the device  $V_{DD}$  is having power applied to it from the  $V_{SS}$  voltage level. As the device powers up, the  $V_{OUT}$  pin will float to an unknown value. When the device's  $V_{DD}$  is above the transistor threshold voltage of the device, the output will start being pulled low. After the  $V_{DD}$  is above the POR/BOR trip point ( $V_{BOR}/V_{POR}$ ), the resistor network's wiper will be loaded with the POR value (mid-scale). The volatile memory determines the analog output ( $V_{OUT}$ ) pin voltage. After the device is powered-up, the user can update the device memory.

When the rising  $V_{DD}$  voltage crosses the  $V_{POR}$  trip point (a Power-on Reset event), the following occurs:

- The default DAC register value is latched into volatile DAC register
- The default configuration bit values are latched into volatile configuration bits
- POR Status bit is set ('1')
- The Reset Delay Timer ( $t_{POR}$ ) starts; when the reset delay timer ( $t_{POR}$ ) times out, the SPI serial interface is operational. During this delay time, the SPI interface will not accept commands.
- The Device Memory Address pointer is forced to 00h.

The analog output ( $V_{OUT}$ ) state will be determined by the state of the volatile configuration bits and the DAC register.

Figure 4-1 illustrates the conditions for power-up and power-down events under typical conditions.

## 4.1.2 BROWN-OUT RESET

The Brown-out Reset occurs when a device had power applied to it and that power (voltage) drops below the specified range.

When the falling  $V_{DD}$  voltage crosses the  $V_{POR}$  trip point (BOR event), the following occurs:

- Serial Interface is disabled
- Device is forced into a Power-Down state ( $PDXB:PDxA = '11'$ ). Analog circuitry is turned off
- Volatile DAC Register is forced to 000h
- Volatile configuration bits  $VRxB:VRxA$  and  $Gx$  are forced to '0'

If the  $V_{DD}$  voltage decreases below the  $V_{RAM}$  voltage, all volatile memory may become corrupted.

As the voltage recovers above the  $V_{POR}/V_{BOR}$  voltage, see Section 4.1.1, "Power-on Reset".

Serial commands not completed due to a brown-out condition may cause the memory location to become corrupted.

Figure 4-1 illustrates the conditions for power-up and power-down events under typical conditions.

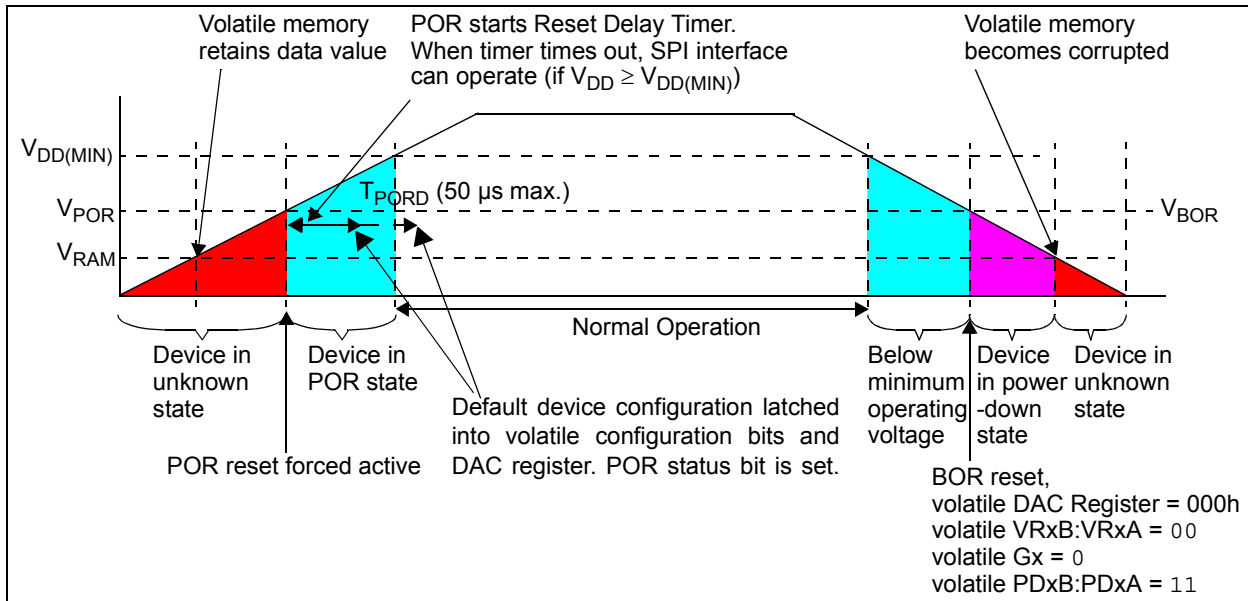


FIGURE 4-1: Power-on Reset Operation.

## 4.2 Device Memory

User memory includes two types of memory:

- **Volatile Register Memory (RAM)**
- **Device Configuration Memory**

Each memory address is 16 bits wide. The memory mapped register space is shown in [Table 4-1](#). (see [Section 4.2.2, “Device Configuration Memory”](#)).

### 4.2.1 VOLATILE REGISTER MEMORY (RAM)

There are up to five volatile memory locations:

- DAC0 and DAC1 Output Value Registers
- V<sub>REF</sub> Select Register
- Power-Down Configuration Register
- Gain and Status Register

The volatile memory starts functioning when the device V<sub>DD</sub> is at (or above) the RAM retention voltage (V<sub>RAM</sub>). The volatile memory will be loaded with the default device values when the V<sub>DD</sub> rises across the V<sub>POR</sub>/V<sub>BOR</sub> voltage trip point.

**TABLE 4-1: MEMORY MAP (X16)**

Address	Function
00h	Volatile DAC0 Register
01h	Volatile DAC1 Register
02h	Reserved (1)
03h	Reserved (1)
04h	Reserved (1)
05h	Reserved (1)
06h	Reserved (1)
07h	Reserved (1)
08h	V <sub>REF</sub> Register
09h	Power-Down Register
0Ah	Gain and Status Register
0Bh	Reserved (1)
0Ch	Reserved (1)
0Dh	Reserved (1)
0Eh	Reserved (1)
0Fh	Reserved (1)

Address	Function
10h	Reserved (1, 2)
11h	Reserved (1, 2)
12h	Reserved (1, 2)
13h	Reserved (1, 2)
14h	Reserved (1, 2)
15h	Reserved (1, 2)
16h	Reserved (1, 2)
17h	Reserved (1, 2)
18h	Reserved (1, 2)
19h	Reserved (1, 2)
1Ah	Reserved (1, 2)
1Bh	Reserved (1, 2)
1Ch	Reserved (1, 2)
1Dh	Reserved (1, 2)
1Eh	Reserved (1, 2)
1Fh	Reserved (1, 2)

 Volatile Memory address range

 Nonvolatile Memory address range

- Note 1:** Reading a reserved memory location will result in the SPI command Command Error condition. The SDO pin will output all '0's. Forcing the CS pin to the V<sub>IH</sub> state will reset the SPI interface.
- 2:** Nonvolatile memory address range is shown to reflect memory map compatibility with the MCP48FEBXX family of devices.

# MCP48FVBXX

## 4.2.2 DEVICE CONFIGURATION MEMORY

The STATUS register is described in [Register 4-4](#).

## 4.2.3 UNIMPLEMENTED REGISTER BITS

Read commands of a valid location will read unimplemented bits as '0'.

## 4.2.4 UNIMPLEMENTED (RESERVED) LOCATIONS


Normal (voltage) commands (read or write) to any unimplemented memory address (reserved) will result in a command error condition (CMDERR). Read commands of a reserved location will read bits as '1'.

### 4.2.4.1 Default Factory POR Memory State

[Table 4-2](#) shows the default factory POR initialization of the device memory map for the 8-, 10- and 12-bit devices.

**TABLE 4-2: FACTORY DEFAULT POR / BOR VALUES**

Address	Function	POR/BOR Value			Address	Function	POR/BOR Value		
		8-bit	10-bit	12-bit			8-bit	10-bit	12-bit
00h	Volatile DAC0 Register	7Fh	1FFh	7FFh	10h	Reserved (1, 2)	FFh	3FFh	FFFh
01h	Volatile DAC1 Register	7Fh	1FFh	7FFh	11h	Reserved (1, 2)	FFh	3FFh	FFFh
02h	Reserved (1)	FFh	3FFh	FFFh	12h	Reserved (1, 2)	FFh	3FFh	FFFh
03h	Reserved (1)	FFh	3FFh	FFFh	13h	Reserved (1, 2)	FFh	3FFh	FFFh
04h	Reserved (1)	FFh	3FFh	FFFh	14h	Reserved (1, 2)	FFh	3FFh	FFFh
05h	Reserved (1)	FFh	3FFh	FFFh	15h	Reserved (1, 2)	FFh	3FFh	FFFh
06h	Reserved (1)	FFh	3FFh	FFFh	16h	Reserved (1, 2)	FFh	3FFh	FFFh
07h	Reserved (1)	FFh	3FFh	FFFh	17h	Reserved (1, 2)	FFh	3FFh	FFFh
08h	V <sub>REF</sub> Register	0000h	0000h	0000h	18h	Reserved (1, 2)	FFh	3FFh	FFFh
09h	Power-Down Register	0000h	0000h	0000h	19h	Reserved (1, 2)	FFh	3FFh	FFFh
0Ah	Gain and Status Register	0080h	0080h	0080h	1Ah	Reserved (1, 2)	FFh	3FFh	FFFh
0Bh	Reserved (1)	FFh	3FFh	FFFh	1Bh	Reserved (1, 2)	FFh	3FFh	FFFh
0Ch	Reserved (1)	FFh	3FFh	FFFh	1Ch	Reserved (1, 2)	FFh	3FFh	FFFh
0Dh	Reserved (1)	FFh	3FFh	FFFh	1Dh	Reserved (1, 2)	FFh	3FFh	FFFh
0Eh	Reserved (1)	FFh	3FFh	FFFh	1Eh	Reserved (1, 2)	FFh	3FFh	FFFh
0Fh	Reserved (1)	FFh	3FFh	FFFh	1Fh	Reserved (1, 2)	FFh	3FFh	FFFh

 Volatile Memory address range

 Nonvolatile Memory address range

**Note 1:** Reading a reserved memory location will result in the SPI command Command Error condition. The SDO pin will output all '0's. Forcing the  $\overline{CS}$  pin to the V<sub>IH</sub> state will reset the SPI interface.

**2:** Nonvolatile memory address range is shown to reflect memory map compatibility with the MCP48FEBXX family of devices.

## 4.2.5 DEVICE REGISTERS

Register 4-1 shows the format of the DAC Output Value registers. These registers will be either 8 bits, 10 bits, or 12 bits wide. The values are right justified.

### REGISTER 4-1: DAC0 AND DAC1 REGISTERS

	U-0	U-0	U-0	U-0	R/W-0	R/W-0	R/W-0	R/W-0	R/W-0	R/W-0	R/W-0	R/W-0	R/W-0	R/W-0	R/W-0	
12-bit	—	—	—	—	D11	D10	D09	D08	D07	D06	D05	D04	D03	D02	D01	D00
10-bit	—	—	—	—	—(1)	—(1)	D09	D08	D07	D06	D05	D04	D03	D02	D01	D00
8-bit	—	—	—	—	—(1)	—(1)	—(1)	—(1)	D07	D06	D05	D04	D03	D02	D01	D00
	bit 15															bit 0

#### Legend:

R = Readable bit      W = Writable bit      U = Unimplemented bit, read as '0'  
 -n = Value at POR      '1' = Bit is set      '0' = Bit is cleared      x = Bit is unknown  
 = 12-bit device       = 10-bit device       = 8-bit device

12-bit	10-bit	8-bit	
bit 15-12	bit 15-10	bit 15-8	<b>Unimplemented:</b> Read as '0'
bit 11-0	—	—	<b>D11-D00:</b> DAC Output value - 12-bit devices FFFh =Full-Scale output value 7FFh =Mid-Scale output value 000h =Zero-Scale output value
—	bit 9-0	—	<b>D09-D00:</b> DAC Output value - 10-bit devices 3FFh =Full-Scale output value 1FFh =Mid-Scale output value 000h =Zero-Scale output value
—	—	bit 7-0	<b>D07-D00:</b> DAC Output value - 8-bit devices FFh =Full-Scale output value 7Fh =Mid-Scale output value 000h =Zero-Scale output value

**Note 1:** Unimplemented bit, read as '0'.

# MCP48FVBXX

Register 4-2 shows the format of the Voltage Reference Control Register. Each DAC has two bits to control the source of the voltage reference of the DAC.

**REGISTER 4-2: VOLTAGE REFERENCE (VREF) CONTROL REGISTER (ADDRESS 08h)**

	U-0	U-0	U-0	U-0	U-0	U-0	U-0	U-0	U-0	U-0	U-0	R/W-0	R/W-0	R/W-0	R/W-0
Single	—	—	—	—	—	—	—	—	—	—	—	— <sup>(1)</sup>	— <sup>(1)</sup>	VR0B	VR0A
Dual	—	—	—	—	—	—	—	—	—	—	—	VR1B	VR1A	VR0B	VR0A
	bit 15														bit 0

**Legend:**

R = Readable bit                      W = Writable bit                      U = Unimplemented bit, read as '0'  
 -n = Value at POR                      '1' = Bit is set                      '0' = Bit is cleared                      x = Bit is unknown  
 = Single-channel device                       = Dual-channel device

Single	Dual	
bit 15-2	bit 15-4	<b>Unimplemented:</b> Read as '0'
bit 1-0	bit 3-0	<b>VRxB-VRxA:</b> DAC Voltage Reference Control bits
		11 =V <sub>REF</sub> pin (Buffered); V <sub>REF</sub> buffer enabled
		10 =V <sub>REF</sub> pin (Unbuffered); V <sub>REF</sub> buffer disabled
		01 =Internal Band Gap (1.22V typical); V <sub>REF</sub> buffer enabled
		V <sub>REF</sub> voltage driven when powered-down
		00 =V <sub>DD</sub> (Unbuffered); V <sub>REF</sub> buffer disabled.
		Use this state with Power-Down bits for lowest current.

**Note 1:** Unimplemented bit, read as '0'.

Register 4-3 shows the format of the Power-Down Control Register. Each DAC has two bits to control the Power-Down state of the DAC.

## REGISTER 4-3: POWER-DOWN CONTROL REGISTER (ADDRESS 09h)

	U-0	U-0	U-0	U-0	U-0	U-0	U-0	U-0	U-0	U-0	U-0	U-0	R/W-0	R/W-0	R/W-0	R/W-0
Single	—	—	—	—	—	—	—	—	—	—	—	—	— <sup>(1)</sup>	— <sup>(1)</sup>	PD0B	PD0A
Dual	—	—	—	—	—	—	—	—	—	—	—	—	PD1B	PD1A	PD0B	PD0A
	bit 15												bit 0			

### Legend:

R = Readable bit

W = Writable bit

U = Unimplemented bit, read as '0'

-n = Value at POR

'1' = Bit is set

'0' = Bit is cleared

x = Bit is unknown

= Single-channel device

= Dual-channel device

Single      Dual

bit 15-2      bit 15-4      **Unimplemented:** Read as '0'

bit 1-0      bit 3-0      **PDxB-PDxA:** DAC Power-Down Control bits <sup>(2)</sup>

11 =Powered Down -  $V_{OUT}$  is open circuit.

10 =Powered Down -  $V_{OUT}$  is loaded with a 100 k $\Omega$  resistor to ground.

01 =Powered Down -  $V_{OUT}$  is loaded with a 1 k $\Omega$  resistor to ground.

00 =Normal Operation (Not powered-down)

**Note 1:** Unimplemented bit, read as '0'.

**2:** See [Table 5-5](#) and [Figure 5-10](#) for more details.

# MCP48FVBXX

Register 4-4 shows the format of the volatile Gain Control and System Status Register. Each DAC has one bit to control the gain of the DAC and three Status bits.

**REGISTER 4-4: GAIN CONTROL AND SYSTEM STATUS REGISTER (ADDRESS 0Ah)**

	U-0	U-0	U-0	U-0	U-0	U-0	R/W-0	R/W-0	R/C-1	U-0	U-0	U-0	U-0	U-0	U-0
Single	—	—	—	—	—	—	— <sup>(1)</sup>	G0	POR	—	—	—	—	—	—
Dual	—	—	—	—	—	—	G1	G0	POR	—	—	—	—	—	—
	bit 15														bit 0

**Legend:**

R = Readable bit      W = Writable bit      C = Clearable bit      U = Unimplemented bit, read as '0'  
 -n = Value at POR      '1' = Bit is set      '0' = Bit is cleared      x = Bit is unknown  
 = Single-channel device       = Dual-channel device

Single	Dual	
bit 15-9	bit 15-10	<b>Unimplemented:</b> Read as '0'
—	bit 9	<b>G1:</b> DAC1 Output Driver Gain control bits ( <b>Dual-channel device only</b> ) 1 =2x Gain 0 =1x Gain
bit 8	bit 8	<b>G0:</b> DAC0 Output Driver Gain control bits 1 =2x Gain 0 =1x Gain
bit 7	bit 7	<b>POR:</b> Power-on Reset (Brown-out Reset) Status bit This bit indicates if a Power-on Reset (POR) or Brown-out Reset (BOR) event has occurred since the last read command of this register. Reading this register clears the state of the POR Status bit. 1 = A POR (BOR) event occurred since the last read of this register. Reading this register clears this bit. 0 = A POR (BOR) event has not occurred since the last read of this register.
bit 6-0	bit 6-0	<b>Unimplemented:</b> Read as '0'

**Note 1:** Unimplemented bit, read as '0'.

## 5.0 DAC CIRCUITRY

The Digital-to-Analog Converter circuitry converts a digital value into its analog representation. The description details the functional operation of the device.

The DAC Circuit uses a resistor ladder implementation. Devices have up to two DACs.

Figure 5-1 shows the functional block diagram for the MCP48FVBXX DAC circuitry.

The functional blocks of the DAC include:

- Resistor Ladder
- Voltage Reference Selection
- Output Buffer/V<sub>OUT</sub> Operation
- Internal Band Gap (as a voltage reference)
- Latch Pin (LAT)
- Power-Down Operation

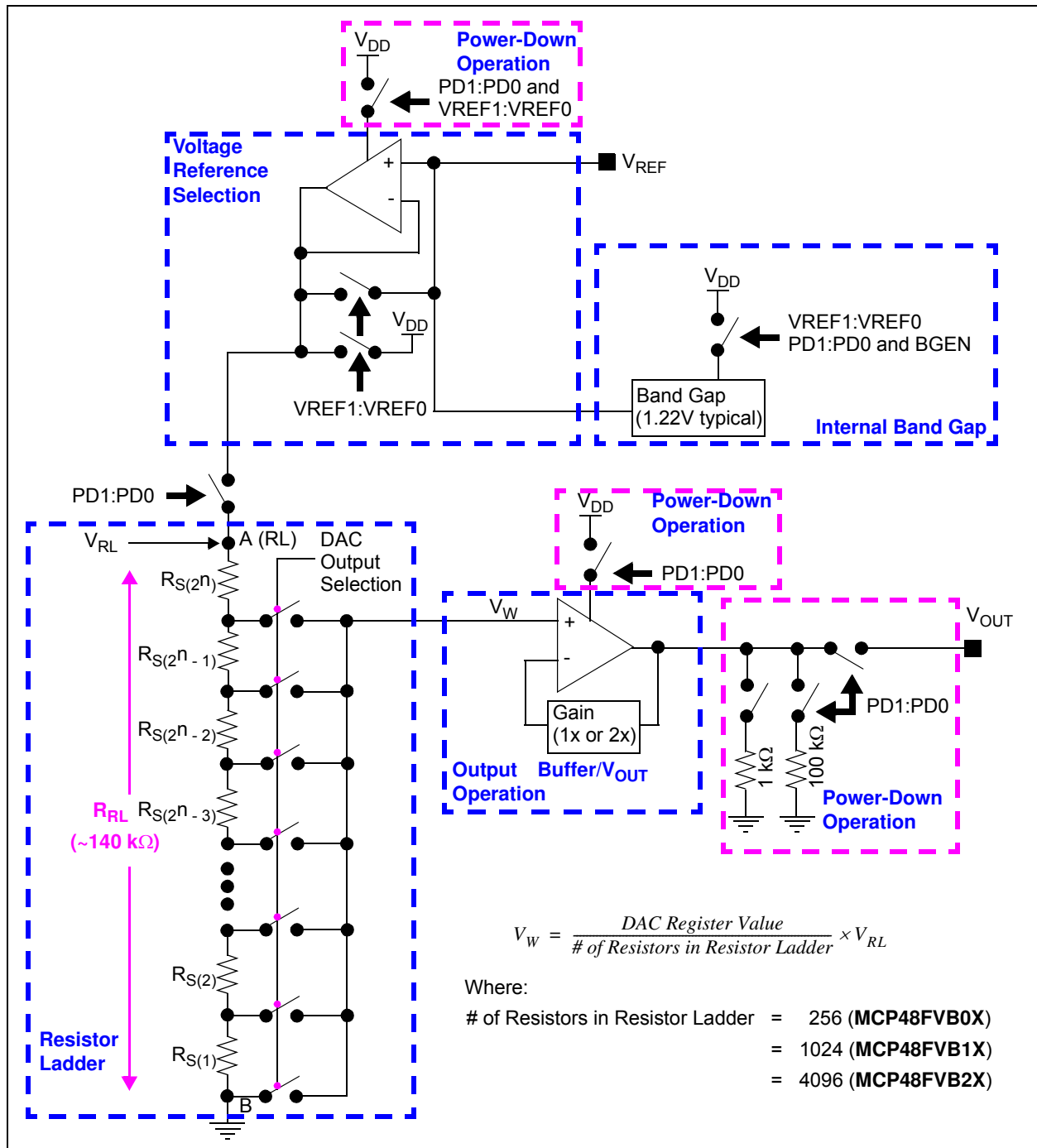


FIGURE 5-1: MCP48FVBXX DAC Module Block Diagram.

# MCP48FVBXX

## 5.1 Resistor Ladder

The Resistor Ladder is a digital potentiometer with the B terminal internally grounded and the A terminal connected to the selected reference voltage (see Figure 5-2). The volatile DAC register controls the wiper position. The wiper voltage ( $V_W$ ) is proportional to the DAC register value divided by the number of resistor elements ( $R_S$ ) in the ladder (256, 1024 or 4096) related to the  $V_{RL}$  voltage.

The output of the resistor network will drive the input of an output buffer.

The Resistor Network is made up of these three parts:

- Resistor Ladder (string of  $R_S$  elements)
- Wiper switches
- DAC Register decode

The resistor ladder ( $R_{RL}$ ) has a typical impedance of approximately 140 k $\Omega$ . This resistor ladder resistance ( $R_{RL}$ ) may vary from device to device by up to  $\pm 20\%$ . Since this is a voltage divider configuration, the actual  $R_{RL}$  resistance does not affect the output given a fixed voltage at  $V_{RL}$ .

Equation 5-1 shows the calculation for the step resistance:

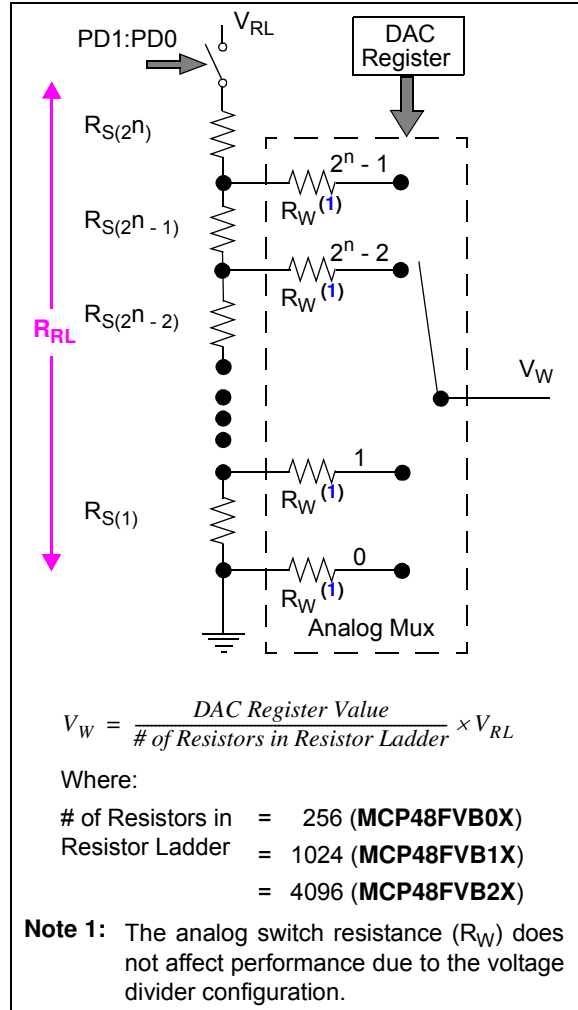
### EQUATION 5-1: $R_S$ CALCULATION

$R_S = \frac{R_{RL}}{(256)}$	8-bit device
-----	
$R_S = \frac{R_{RL}}{(1024)}$	10-bit device
-----	
$R_S = \frac{R_{RL}}{(4096)}$	12-bit device

**Note:** The maximum wiper position is  $2^n - 1$ , while the number of resistors in the resistor ladder is  $2^n$ . This means that when the DAC register is at full-scale, there is one resistor element ( $R_S$ ) between the wiper and the  $V_{RL}$  voltage.

If the unbuffered  $V_{REF}$  pin is used as the  $V_{RL}$  voltage source, this voltage source should have a low output impedance.

When the DAC is powered-down, the resistor ladder is disconnected from the selected reference voltage.



**FIGURE 5-2:** Resistor Ladder Model Block Diagram.

## 5.2 Voltage Reference Selection

The resistor ladder has up to four sources for the reference voltage. Two User Control bits (VREF1:VREF0) are used to control the selection, with the selection connected to the  $V_{RL}$  node (see Figures 5-3 and 5-4). The four voltage source options for the Resistor Ladder are:

1.  $V_{DD}$  pin voltage
2. Internal Voltage Reference ( $V_{BG}$ )
3.  $V_{REF}$  pin voltage unbuffered
4.  $V_{REF}$  pin voltage internally buffered

The selection of the voltage is specified with the volatile VREF1:VREF0 configuration bits (see Register 4-2). On a POR/BOR event, the default state of the configuration bits is latched into the volatile VREF1:VREF0 configuration bits.

When the user selects the  $V_{DD}$  as reference, the  $V_{REF}$  pin voltage is not connected to the resistor ladder.

If the  $V_{REF}$  pin is selected, then a selection has to be made between the Buffered or Unbuffered mode.

### 5.2.1 UNBUFFERED MODE

The  $V_{REF}$  pin voltage may be from  $V_{SS}$  to  $V_{DD}$ .

**Note 1:** The voltage source should have a low output impedance. If the voltage source has a high output impedance, then the voltage on the  $V_{REF}$  pin would be lower than expected. The resistor ladder has a typical impedance of 140 k $\Omega$  and a typical capacitance of 29 pF.

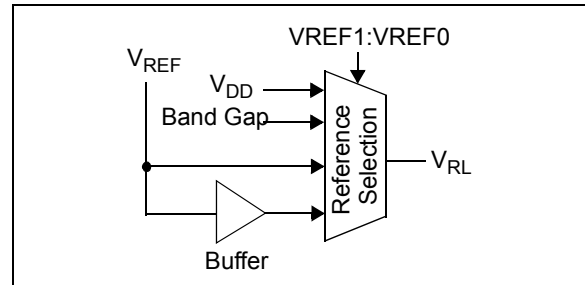
- 2: If the  $V_{REF}$  pin is tied to the  $V_{DD}$  voltage,  $V_{DD}$  mode (VREF1:VREF0 = '00') is recommended.

### 5.2.2 BUFFERED MODE

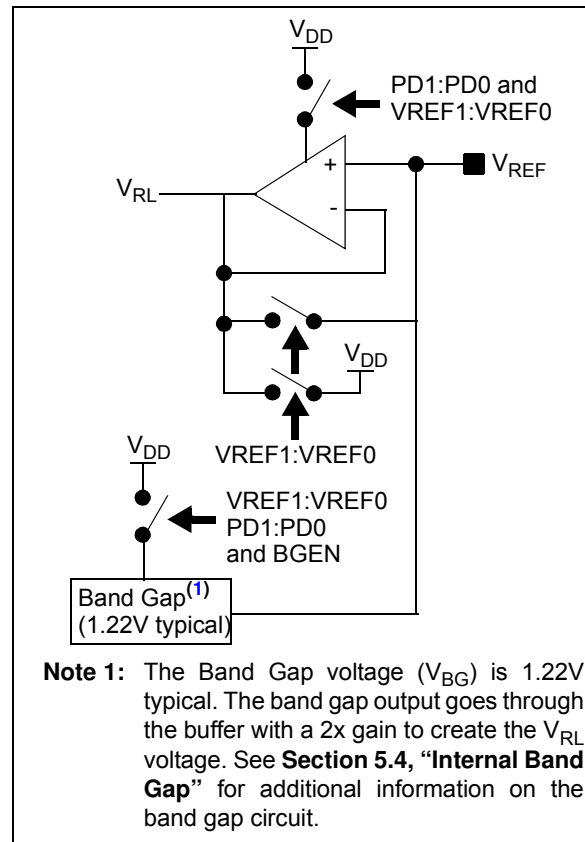
The  $V_{REF}$  pin voltage may be from 0.01V to  $V_{DD} - 0.04V$ . The input buffer (amplifier) provides low offset voltage, low noise, and a very high input impedance, with only minor limitations on the input range and frequency response.

**Note 1:** Any variation or noises on the reference source can directly affect the DAC output. The reference voltage needs to be as clean as possible for accurate DAC performance.

- 2: If the  $V_{REF}$  pin is tied to the  $V_{DD}$  voltage,  $V_{DD}$  mode (VREF1:VREF0 = '00') is recommended.



**FIGURE 5-3:** Resistor Ladder Reference Voltage Selection Block Diagram.



**Note 1:** The Band Gap voltage ( $V_{BG}$ ) is 1.22V typical. The band gap output goes through the buffer with a 2x gain to create the  $V_{RL}$  voltage. See Section 5.4, "Internal Band Gap" for additional information on the band gap circuit.

**FIGURE 5-4:** Reference Voltage Selection Implementation Block Diagram.

### 5.2.3 BAND GAP MODE

If the Internal Band Gap is selected, then the external  $V_{REF}$  pin should not be driven and only use high-impedance loads. Decoupling capacitors are recommended for optimal operation.

The band gap output is buffered, but the internal switches limit the current that the output should source to the  $V_{REF}$  pin. The resistor ladder buffer is used to drive the Band Gap voltage for the cases of multiple DAC outputs. This ensures that the resistor ladders are always properly sourced when the band gap is selected.

# MCP48FVBXX

## 5.3 Output Buffer/ $V_{OUT}$ Operation

The Output Driver buffers the wiper voltage ( $V_W$ ) of the Resistor Ladder.

The DAC output is buffered with a low-power, precision output amplifier (op amp). This amplifier provides a rail-to-rail output with low offset voltage and low noise. The amplifier's output can drive the resistive and high-capacitive loads without oscillation. The amplifier provides a maximum load current which is enough for most programmable voltage reference applications. Refer to [Section 1.0, "Electrical Characteristics"](#) for the specifications of the output amplifier.

**Note:** The load resistance must be kept higher than 5 k $\Omega$  for stable and expected analog output (to meet electrical specifications).

[Figure 5-5](#) shows the block diagram of the output driver circuit.

The user can select the output gain of the output amplifier. The gain options are:

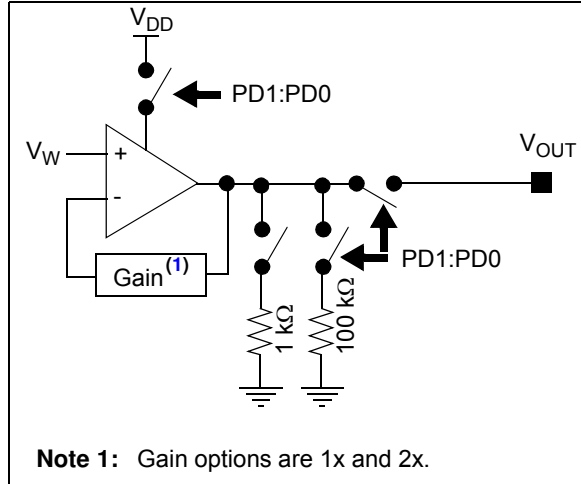
- a) Gain of 1, with either the  $V_{DD}$  or  $V_{REF}$  pin used as reference voltage.
- b) Gain of 2.

Power-down logic also controls the output buffer operation (see [Section 5.6, "Power-Down Operation"](#)) for additional information on Power-Down. In any of the three power-down modes, the op amp is powered-down and its output becomes a high impedance to the  $V_{OUT}$  pin.

[Table 5-1](#) shows the gain bit operation.

**TABLE 5-1: OUTPUT DRIVER GAIN**

Gain Bit	Gain	Comment
0	1	—
1	2	Limits $V_{REF}$ pin voltages relative to device $V_{DD}$ voltage.



**FIGURE 5-5:** Output Driver Block Diagram.

### 5.3.1 PROGRAMMABLE GAIN

The amplifier's gain is controlled by the Gain (G) configuration bit (see [Register 4-4](#)) and the  $V_{RL}$  reference selection (see [Section 5.2, "Voltage Reference Selection"](#)).

The volatile G bit value can be modified by:

- POR events
- BOR events
- SPI write commands

## 5.3.2 OUTPUT VOLTAGE

The volatile DAC Register values, along with the device configuration bits, control the analog  $V_{OUT}$  voltage. The volatile DAC Register's value is unsigned binary. The formula for the output voltage is given in Equation 5-2. Table 5-3 shows examples of volatile DAC register values and the corresponding theoretical  $V_{OUT}$  voltage for the MCP48FVBXX devices.

### EQUATION 5-2: CALCULATING OUTPUT VOLTAGE ( $V_{OUT}$ )

$$V_{OUT} = \frac{V_{RL} \times \text{DAC Register Value}}{\# \text{ of Resistors in Resistor Ladder}} \times \text{Gain}$$

Where:

# of Resistors in Resistor Ladder = 4096 (MCP48FVB2X)  
 = 1024 (MCP48FVB1X)  
 = 256 (MCP48FVB0X)

**Note:** When Gain = 2 ( $V_{RL} = V_{REF}$ ) and if  $V_{REF} > V_{DD} / 2$ , the  $V_{OUT}$  voltage will be limited to  $V_{DD}$ . So if  $V_{REF} = V_{DD}$ , then the  $V_{OUT}$  voltage will not change for volatile DAC Register values mid-scale and greater, since the op amp is at full-scale output.

The following events update the DAC register value and therefore the analog voltage output ( $V_{OUT}$ ):

- Power-on Reset
- Brown-out Reset
- Write command

The  $V_{OUT}$  voltage will start driving to the new value after any of these events has occurred.

## 5.3.3 STEP VOLTAGE ( $V_S$ )

The Step Voltage is dependent on the device resolution and the calculated output voltage range. 1 LSB is defined as the ideal voltage difference between two successive codes. The step voltage can easily be calculated by using Equation 5-3. Theoretical step voltages are shown in Table 5-2 for several  $V_{REF}$  voltages.

### EQUATION 5-3: $V_S$ CALCULATION

$$V_S = \frac{V_{RL}}{\# \text{ of Resistors in Resistor Ladder}} \times \text{Gain}$$

Where:

# of Resistors in Resistor Ladder = 4096 (12-bit)  
 = 1024 (10-bit)  
 = 256 (8-bit)

**TABLE 5-2: THEORETICAL STEP VOLTAGE ( $V_S$ )<sup>(1)</sup>**

	$V_{REF}$					
	5.0	2.7	1.8	1.5	1.0	
$V_S$	1.22 mV	659 $\mu$ V	439 $\mu$ V	366 $\mu$ V	244 $\mu$ V	12-bit
	4.88 mV	2.64 mV	1.76 mV	1.46 mV	977 $\mu$ V	10-bit
	19.5 mV	10.5 mV	7.03 mV	5.86 mV	3.91 mV	8-bit

**Note 1:** When Gain = 1x,  $V_{FS} = V_{RL}$ , and  $V_{ZS} = 0V$ .

# MCP48FVBXX

## 5.3.4 OUTPUT SLEW RATE

Figure 5-6 shows an example of the slew rate of the  $V_{OUT}$  pin. The slew rate can be affected by the characteristics of the circuit connected to the  $V_{OUT}$  pin.

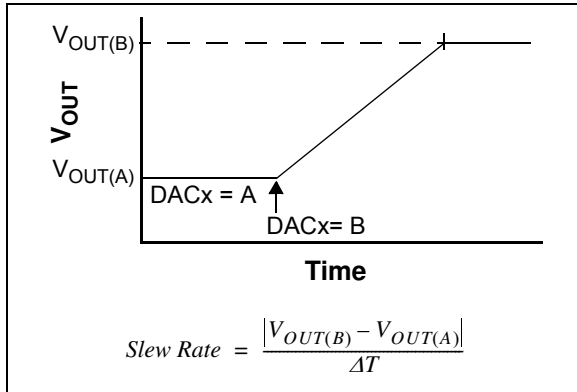


FIGURE 5-6:  $V_{OUT}$  Pin Slew Rate.

### 5.3.4.1 Small Capacitive Load

With a small capacitive load, the output buffer's current is not affected by the capacitive load ( $C_L$ ). But still, the  $V_{OUT}$  pin's voltage is not a step transition from one output value (DAC register value) to the next output value. The change of the  $V_{OUT}$  voltage is limited by the output buffer's characteristics, so the  $V_{OUT}$  pin voltage will have a slope from the initial voltage to the new voltage. This slope is fixed for the output buffer, and is referred to as the buffer slew rate ( $SR_{BUF}$ ).

### 5.3.4.2 Large Capacitive Load

With a larger capacitive load, the slew rate is determined by two factors:

- The output buffer's short-circuit current ( $I_{SC}$ )
- The  $V_{OUT}$  pin's external load

$I_{OUT}$  cannot exceed the output buffer's short-circuit current ( $I_{SC}$ ), which fixes the output buffer slew rate ( $SR_{BUF}$ ). The voltage on the capacitive load ( $C_L$ ),  $V_{CL}$ , changes at a rate proportional to  $I_{OUT}$ , which fixes a capacitive load slew rate ( $SR_{CL}$ ).

The  $V_{CL}$  voltage slew rate is limited to the slower of the output buffer's internally set slew rate ( $SR_{BUF}$ ) and the capacitive load slew rate ( $SR_{CL}$ ).

## 5.3.5 DRIVING RESISTIVE AND CAPACITIVE LOADS

The  $V_{OUT}$  pin can drive up to 100 pF of capacitive load in parallel with a 5 k $\Omega$  resistive load (to meet electrical specifications). A  $V_{OUT}$  vs. Resistive Load characterization graph is provided in the Typical Performance Curves for this device (see MCP48FVBXX - "Typical Performance Curves" **DS20005440**).

$V_{OUT}$  drops slowly as the load resistance decreases after about 3.5 k $\Omega$ . It is recommended to use a load with  $R_L$  greater than 5 k $\Omega$ .

Driving large capacitive loads can cause stability problems for voltage feedback op amps. As the load capacitance increases, the feedback loop's phase margin decreases and the closed-loop bandwidth is reduced. This produces gain peaking in the frequency response with overshoot and ringing in the step response. That is, since the  $V_{OUT}$  pin's voltage does not quickly follow the buffer's input voltage (due to the large capacitive load), the output buffer will overshoot the desired target voltage. Once the driver detects this overshoot, it compensates by forcing it to a voltage below the target. This causes voltage ringing on the  $V_{OUT}$  pin.

When driving large capacitive loads with the output buffer, a small series resistor ( $R_{ISO}$ ) at the output (see Figure 5-7) improves the output buffer's stability (feedback loop's phase margin) by making the output load resistive at higher frequencies. The bandwidth will be generally lower than the bandwidth with no capacitive load.

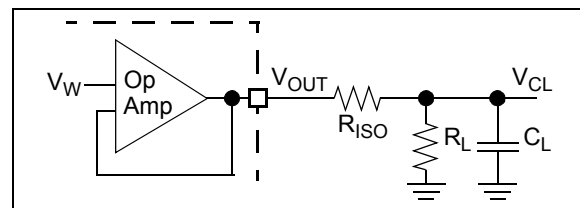


FIGURE 5-7: Circuit to Stabilize Output Buffer for Large Capacitive Loads ( $C_L$ ).

The  $R_{ISO}$  resistor value for your circuit needs to be selected. The resulting frequency response peaking and step response overshoot for this  $R_{ISO}$  resistor value should be verified on the bench. Modify the  $R_{ISO}$ 's resistance value until the output characteristics meet your requirements.

A method to evaluate the system's performance is to inject a step voltage on the  $V_{REF}$  pin and observe the  $V_{OUT}$  pin's characteristics.

**Note:** Additional insight into circuit design for driving capacitive loads can be found in AN884 - "Driving Capacitive Loads With Op Amps" (DS00884).

**TABLE 5-3: DAC INPUT CODE VS. CALCULATED ANALOG OUTPUT (V<sub>OUT</sub>) (V<sub>DD</sub> = 5.0V)**

Device	Volatile DAC Register Value	V <sub>RL</sub> <sup>(1)</sup>	LSb		Gain Selection <sup>(2)</sup>	V <sub>OUT</sub> <sup>(3)</sup>	
			Equation	μV		Equation	V
MCP48FVB2X (12-bit)	1111 1111 1111	5.0V	5.0V/4096	1,220.7	1x	$V_{RL} * (4095/4096) * 1$	4.998779
		2.5V	2.5V/4096	610.4	1x	$V_{RL} * (4095/4096) * 1$	2.499390
					2x <sup>(2)</sup>	$V_{RL} * (4095/4096) * 2$	4.998779
	0111 1111 1111	5.0V	5.0V/4096	1,220.7	1x	$V_{RL} * (2047/4096) * 1$	2.498779
		2.5V	2.5V/4096	610.4	1x	$V_{RL} * (2047/4096) * 1$	1.249390
					2x <sup>(2)</sup>	$V_{RL} * (2047/4096) * 2$	2.498779
	0011 1111 1111	5.0V	5.0V/4096	1,220.7	1x	$V_{RL} * (1023/4096) * 1$	1.248779
		2.5V	2.5V/4096	610.4	1x	$V_{RL} * (1023/4096) * 1$	0.624390
					2x <sup>(2)</sup>	$V_{RL} * (1023/4096) * 2$	1.248779
	0000 0000 0000	5.0V	5.0V/4096	1,220.7	1x	$V_{RL} * (0/4096) * 1$	0
		2.5V	2.5V/4096	610.4	1x	$V_{RL} * (0/4096) * 1$	0
					2x <sup>(2)</sup>	$V_{RL} * (0/4096) * 2$	0
MCP48FVB1X (10-bit)	11 1111 1111	5.0V	5.0V/1024	4,882.8	1x	$V_{RL} * (1023/1024) * 1$	4.995117
		2.5V	2.5V/1024	2,441.4	1x	$V_{RL} * (1023/1024) * 1$	2.497559
					2x <sup>(2)</sup>	$V_{RL} * (1023/1024) * 2$	4.995117
	01 1111 1111	5.0V	5.0V/1024	4,882.8	1x	$V_{RL} * (511/1024) * 1$	2.495117
		2.5V	2.5V/1024	2,441.4	1x	$V_{RL} * (511/1024) * 1$	1.247559
					2x <sup>(2)</sup>	$V_{RL} * (511/1024) * 2$	2.495117
	00 1111 1111	5.0V	5.0V/1024	4,882.8	1x	$V_{RL} * (255/1024) * 1$	1.245117
		2.5V	2.5V/1024	2,441.4	1x	$V_{RL} * (255/1024) * 1$	0.622559
					2x <sup>(2)</sup>	$V_{RL} * (255/1024) * 2$	1.245117
	00 0000 0000	5.0V	5.0V/1024	4,882.8	1x	$V_{RL} * (0/1024) * 1$	0
		2.5V	2.5V/1024	2,441.4	1x	$V_{RL} * (0/1024) * 1$	0
					2x <sup>(2)</sup>	$V_{RL} * (0/1024) * 1$	0
MCP48FVB0X (8-bit)	1111 1111	5.0V	5.0V/256	19,531.3	1x	$V_{RL} * (255/256) * 1$	4.980469
		2.5V	2.5V/256	9,765.6	1x	$V_{RL} * (255/256) * 1$	2.490234
					2x <sup>(2)</sup>	$V_{RL} * (255/256) * 2$	4.980469
	0111 1111	5.0V	5.0V/256	19,531.3	1x	$V_{RL} * (127/256) * 1$	2.480469
		2.5V	2.5V/256	9,765.6	1x	$V_{RL} * (127/256) * 1$	1.240234
					2x <sup>(2)</sup>	$V_{RL} * (127/256) * 2$	2.480469
	0011 1111	5.0V	5.0V/256	19,531.3	1x	$V_{RL} * (63/256) * 1$	1.230469
		2.5V	2.5V/256	9,765.6	1x	$V_{RL} * (63/256) * 1$	0.615234
					2x <sup>(2)</sup>	$V_{RL} * (63/256) * 2$	1.230469
	0000 0000	5.0V	5.0V/256	19,531.3	1x	$V_{RL} * (0/256) * 1$	0
		2.5V	2.5V/256	9,765.6	1x	$V_{RL} * (0/256) * 1$	0
					2x <sup>(2)</sup>	$V_{RL} * (0/256) * 2$	0

- Note 1:** V<sub>RL</sub> is the resistor ladder's reference voltage. It is independent of VREF1:VREF0 selection.
- Note 2:** Gain selection of 2x (Gx = '1') requires voltage reference source to come from V<sub>REF</sub> pin (VREF1:VREF0 = '10' or '11') and requires V<sub>REF</sub> pin voltage (or V<sub>RL</sub>) ≤ V<sub>DD</sub>/2, or from the internal band gap (VREF1:VREF0 = '01').
- Note 3:** These theoretical calculations do not take into account the Offset, Gain and Nonlinearity errors.

# MCP48FVBXX

## 5.4 Internal Band Gap

The internal band gap is designed to drive the Resistor Ladder Buffer.

The resistance of a resistor ladder ( $R_{RL}$ ) is targeted to be 140 k $\Omega$  ( $\pm 40$  k $\Omega$ ), which means a minimum resistance of 100 k $\Omega$ .

The band gap selection can be used across the  $V_{DD}$  voltages while maximizing the  $V_{OUT}$  voltage ranges. For  $V_{DD}$  voltages below the  $2 * \text{Gain} * V_{BG}$  voltage, the output for the upper codes will be clipped to the  $V_{DD}$  voltage. Table 5-4 shows the maximum DAC register code given device  $V_{DD}$  and Gain bit setting.

**TABLE 5-4:  $V_{OUT}$  USING BAND GAP**

$V_{DD}$	DAC Gain	Max DAC Code <sup>(1)</sup>			Comment
		12-bit	10-bit	8-bit	
5.5	1	FFFh	3FFh	FFh	$V_{OUT(max)} = 2.44V$ <sup>(2)</sup>
	2	FFFh	3FFh	FFh	$V_{OUT(max)} = 4.88V$ <sup>(2)</sup>
2.7	1	FFFh	3FFh	FFh	$V_{OUT(max)} = 2.44V$ <sup>(2)</sup>
	2	8DAh	236h	8Dh	~ 0 to 55% range
2.0 <sup>(3)</sup>	1	D1Dh	347h	D1h	~ 0 to 82% range
	2 <sup>(4)</sup>	68Eh	1A3h	68h	~ 0 to 41% range

- Note 1:** Without the  $V_{OUT}$  pin voltage being clipped.  
**Note 2:** When  $V_{BG} = 1.22V$  typical.  
**Note 3:** Band gap performance achieves full performance starting from a  $V_{DD}$  of 2.0V.  
**Note 4:** It is recommended to use Gain = 1 setting instead.

## 5.5 Latch Pin ( $\overline{\text{LAT}}$ )

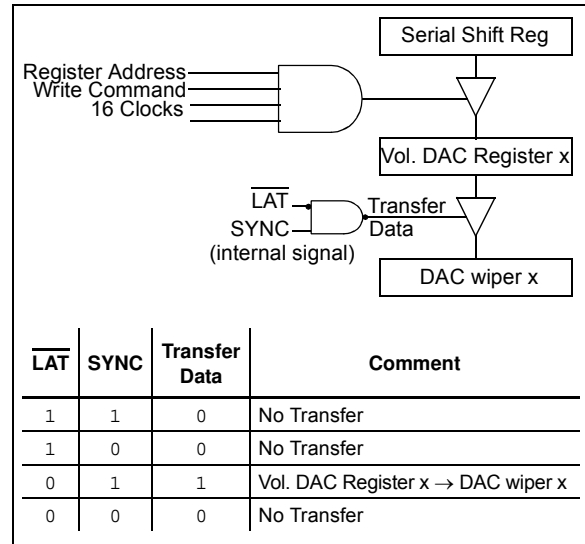
The Latch pin controls when the volatile DAC Register value is transferred to the DAC wiper. This is useful for applications that need to synchronize the wiper(s) updates to an external event, such as zero crossing or updates to the other wipers on the device. The  $\overline{\text{LAT}}$  pin is asynchronous to the serial interface operation.

When the  $\overline{\text{LAT}}$  pin is high, transfers from the volatile DAC register to the DAC wiper are inhibited. The volatile DAC register value(s) can still be updated.

When the  $\overline{\text{LAT}}$  pin is low, the volatile DAC register value is transferred to the DAC wiper.

**Note:** This allows both the volatile DAC0 and DAC1 registers to be updated while the  $\overline{\text{LAT}}$  pin is high, and to have outputs synchronously updated as the  $\overline{\text{LAT}}$  pin is driven low.

Figure 5-8 shows the interaction of the  $\overline{\text{LAT}}$  pin and the loading of the DAC wiper x (from the volatile DAC Register x). The transfers are level driven. If the  $\overline{\text{LAT}}$  pin is held low, the corresponding DAC wiper is updated as soon as the volatile DAC Register value is updated.



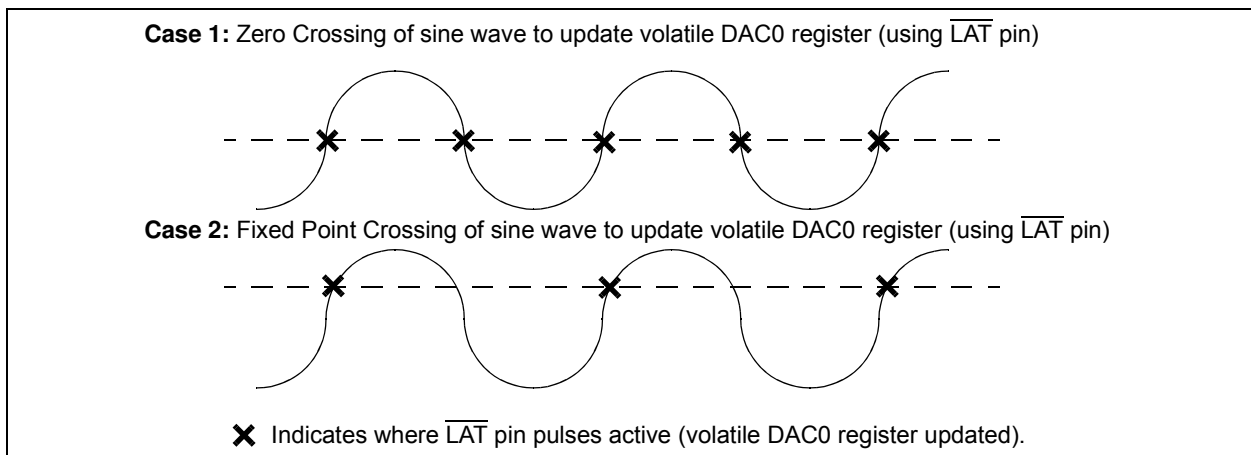
**FIGURE 5-8:**  $\overline{\text{LAT}}$  and DAC Interaction.

The  $\overline{\text{LAT}}$  pin allows the DAC wiper to be updated to an external event as well as have multiple DAC channels/devices update at a common event.

Since the DAC wiper x is updated from the Volatile DAC Register x, all DACs that are associated with a given  $\overline{\text{LAT}}$  pin can be updated synchronously.

If the application does not require synchronization, then this signal should be tied low.

Figure 5-9 shows two cases of using the  $\overline{\text{LAT}}$  pin to control when the wiper register is updated relative to the value of a sine wave signal.



**FIGURE 5-9:** Example Use of  $\overline{\text{LAT}}$  Pin Operation.

# MCP48FVBXX

## 5.6 Power-Down Operation

To allow the application to conserve power when the DAC operation is not required, three power-down modes are available. The Power-Down configuration bits (PD1:PD0) control the power-down operation (see Figure 5-10 and Table 5-5). On devices with multiple DACs, each DAC's power-down mode is individually controllable. All power-down modes do the following:

- Turn off most of the DAC module's internal circuits (output op amp, resistor ladder, et al.)
- Op amp output becomes high-impedance to the  $V_{OUT}$  pin
- Disconnects resistor ladder from reference voltage ( $V_{RL}$ )

Depending on the selected power-down mode, the following will occur:

- $V_{OUT}$  pin is switched to one of two resistive pull-downs (see Table 5-5):
  - 100 k $\Omega$  (typical)
  - 1 k $\Omega$  (typical)
- Op amp is powered-down and the  $V_{OUT}$  pin becomes high-impedance.

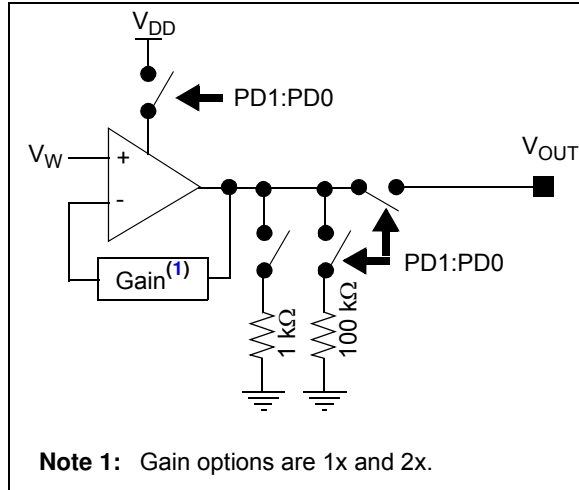
There is a delay ( $T_{PDE}$ ) between the PD1:PD0 bits changing from '00' to either '01', '10' or '11' with the op amp no longer driving the  $V_{OUT}$  output and the pull-down resistors sinking current.

In any of the power-down modes where the  $V_{OUT}$  pin is not externally connected (sinking or sourcing current), the power-down current will typically be ~650 nA for a single-DAC device. As the number of DACs increases, the device's power-down current will also increase.

The Power-Down bits are modified by using a write command to the volatile Power-Down register, or a POR event which loads the default Power-Down register values to the volatile Power-Down register.

Section 7.0, "SPI Commands" describes the SPI commands. The Write Command can be used to update the volatile PD1:PD0 bits.

**Note:** The SPI serial interface circuit is not affected by the Power-Down mode. This circuit remains active in order to receive any command that might come from the host controller device.



**FIGURE 5-10:**  $V_{OUT}$  Power-Down Block Diagram.

**TABLE 5-5: POWER-DOWN BITS AND OUTPUT RESISTIVE LOAD**

PD1	PD0	Function
0	0	Normal operation
0	1	1 k $\Omega$ resistor to ground
1	0	100 k $\Omega$ resistor to ground
1	1	Open circuit

Table 5-6 shows the current sources for the DAC based on the selected source of the DAC's reference voltage and if the device is in normal operating mode or one of the power-down modes.

**TABLE 5-6: DAC CURRENT SOURCES**

Device $V_{DD}$ Current Source	PD1:0 = '00', $V_{REF1:0} =$				PD1:0 $\neq$ '00', $V_{REF1:0} =$			
	00	01	10	11	00	01	10	11
Output Op Amp	Y	Y	Y	Y	N	N	N	N
Resistor Ladder	Y	Y	N <sup>(1)</sup>	Y	N	N	N <sup>(1)</sup>	N
RL Op Amp	N	Y	N	Y	N	N	N	N
Band Gap	N	Y	N	N	N	Y	N	N

**Note 1:** Current is sourced from the  $V_{REF}$  pin, not the device  $V_{DD}$ .

## 5.6.1 EXITING POWER-DOWN

When the device exits Power-Down mode, the following occurs:

- Disabled circuits (op amp, resistor ladder, et al.) are turned on
- The resistor ladder is connected to selected reference voltage ( $V_{RL}$ )
- The selected pull-down resistor is disconnected
- The  $V_{OUT}$  output is driven to the voltage represented by the volatile DAC Register's value and configuration bits

The  $V_{OUT}$  output signal will require time as these circuits are powered-up and the output voltage is driven to the specified value as determined by the volatile DAC register and configuration bits.

**Note:** Since the op amp and resistor ladder were powered-off (0V), the op amp's input voltage ( $V_W$ ) can be considered 0V. There is a delay ( $T_{PDD}$ ) between the PD1:PD0 bits updating to '00' and the op amp driving the  $V_{OUT}$  output. The op amp's settling time (from 0V) needs to be taken into account to ensure the  $V_{OUT}$  voltage reflects the selected value.

A write command forcing the PD1:PD0 bits to '00', will cause the device to exit the power-down mode.

## 5.7 DAC Registers, Configuration Bits, and Status Bits

The MCP48FVBXX devices have volatile memory. [Table 4-2](#) shows the volatile memory and its interaction due to a POR event.

In the volatile memory, there are five configuration bits, the DAC registers and two volatile status bits. The volatile DAC registers will be either 12 bits (MCP48FVB2X), 10 bits (MCP48FVB1X), or 8 bits (MCP48FVB0X) wide.

When the device is first powered-up, it automatically loads the device default values to the volatile memory. The volatile memory determines the analog output ( $V_{OUT}$ ) pin voltage. After the device is powered-up, the user can update the device memory.

The memory is read and written using an SPI interface. Refer to [Sections 6.0, "SPI Serial Interface Module"](#) and [7.0, "SPI Commands"](#) for more details on reading and writing the device's memory.

[Register 4-4](#) shows the operation of the device status bits, and [Table 4-2](#) shows the default factory value of the device configuration bits after a POR/BOR event.

There is one status bit (the POR bit) which indicates if the device  $V_{DD}$  is above or below the POR trip point. After a POR event, this bit is a '1'. Reading the Gain Control and System Status register clears this bit ('0').

# MCP48FVBXX

---

NOTES:

## 6.0 SPI SERIAL INTERFACE MODULE

The MCP48FVBXX's SPI Serial Interface Module supports the SPI serial protocol specification. [Figure 6-1](#) shows a typical SPI interface connection.

The command format and waveforms for the MCP48FVBXX are defined in [Section 7.0, "SPI Commands"](#).

### 6.1 Overview

This section details some of the specific characteristics of the MCP48FVBXX's Serial Interface Module.

The following sections discuss some of these device-specific characteristics:

- [Communication Data Rates](#)
- [POR/BOR](#)
- [Interface Pins \(CS, SCK, SDI, SDO, and LAT/HVC\)](#)

## 6.2 SPI SERIAL INTERFACE

The MCP48FVBXX devices support the SPI serial protocol. This SPI operates in slave mode (does not generate the serial clock).

The SPI interface uses up to four pins. These are:

- $\overline{\text{CS}}$  - Chip Select
- SCK - Serial Clock
- SDI - Serial Data In
- SDO - Serial Data Out

A typical SPI Interface is shown in [Figure 6-1](#). In the SPI interface, the Master's Output pin is connected to the Slave's Input pin, and the Master's Input pin is connected to the Slave's Output pin.

The MCP48FVBXX SPI module supports two (of the four) standard SPI modes. These are Mode 0,0 and 1,1. The SPI mode is determined by the state of the SCK pin ( $V_{IH}$  or  $V_{IL}$ ) when the  $\overline{\text{CS}}$  pin transitions from inactive ( $V_{IH}$ ) to active ( $V_{IL}$ ).

An additional HVC pin is available for High Voltage command support (for compatibility with MCP48FEBXX devices). The HVC pin is high-voltage tolerant.

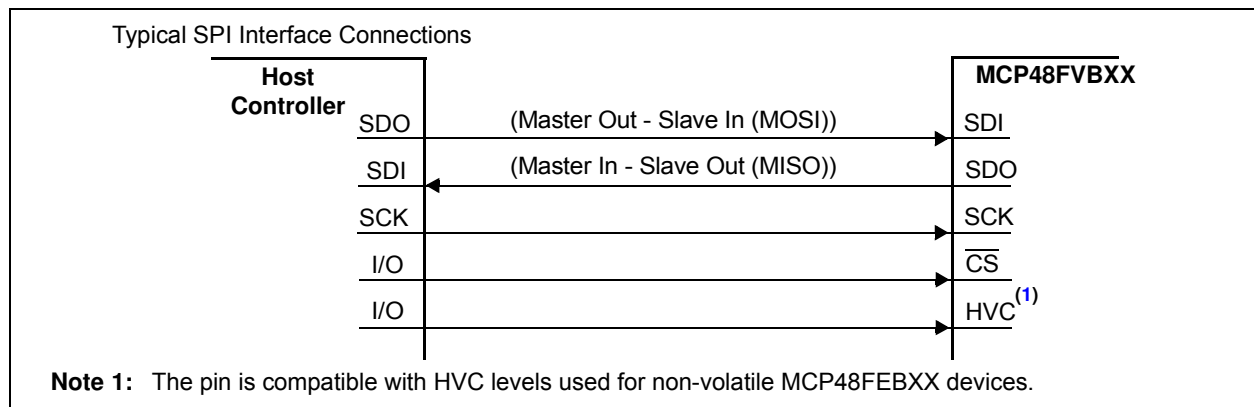
### 6.3 Communication Data Rates

The MCP48FVBXX devices support clock rates (bit rate) of up to 20 MHz for write commands and 10 MHz for read commands.

For most applications, the write time will be considered more important, since that is how the device operation is controlled.

### 6.4 POR/BOR

On a POR/BOR event, the SPI Serial Interface Module state machine is reset, which includes that the Device's Memory Address pointer is forced to 00h.



**FIGURE 6-1:** Typical SPI Interface Block Diagram.

# MCP48FVBXX

## 6.5 Interface Pins ( $\overline{\text{CS}}$ , SCK, SDI, SDO, and LAT/HVC)

The operation of the five interface pins is discussed in this section. These pins are:

- SDI (Serial Data In)
- SDO (Serial Data Out)
- SCK (Serial Clock)
- $\overline{\text{CS}}$  (Chip Select)
- LAT/HVC (High Voltage command)

The serial interface works on a 24-bit boundary. The Chip Select ( $\overline{\text{CS}}$ ) pin frames the SPI commands.

### 6.5.1 SERIAL DATA IN (SDI)

The Serial Data In (SDI) signal is the data signal into the device. The value on this pin is latched on the rising edge of the SCK signal.

### 6.5.2 SERIAL DATA OUT (SDO)

The Serial Data Out (SDO) signal is the data signal out of the device. The value on this pin is driven on the falling edge of the SCK signal.

Once the  $\overline{\text{CS}}$  pin is forced to the active level ( $V_{IL}$ ), the SDO pin will be driven. The state of the SDO pin is determined by the serial bit's position in the command, the command selected, and if there is a command error state (CMDERR).

### 6.5.3 SERIAL CLOCK (SCK) (SPI FREQUENCY OF OPERATION)

The SPI interface is specified to operate up to 20 MHz. The actual clock rate depends on the configuration of the system and the serial command used. Table 6-1 shows the SCK frequency for different configurations.

**TABLE 6-1: SCK FREQUENCY**

Memory Type Access		Command	
		Read	Write
Volatile Memory	SDI, SDO	10 MHz	20 MHz <sup>(1)</sup>

**Note 1:** Write interface speed is faster than read interface speed due to read access times.

### 6.5.4 THE $\overline{\text{CS}}$ SIGNAL

The Chip Select ( $\overline{\text{CS}}$ ) signal is used to select the device and frame a command sequence. To start a command, or sequence of commands, the  $\overline{\text{CS}}$  signal must transition from the inactive state ( $V_{IH}$ ) to the active state ( $V_{IL}$ ).

After the  $\overline{\text{CS}}$  signal has gone active, the SDO pin is driven and the clock bit counter is reset.

**Note:** There is a required delay after the  $\overline{\text{CS}}$  pin goes active to the 1st edge of the SCK pin.

If an error condition occurs for an SPI command, then the command byte's Command Error (CMDERR) bit (on the SDO pin) will be driven low ( $V_{IL}$ ). To exit the error condition, the user must take the  $\overline{\text{CS}}$  pin to the  $V_{IH}$  level.

When the  $\overline{\text{CS}}$  pin returns to the inactive state ( $V_{IH}$ ), the SPI module resets (including the address pointer). While the  $\overline{\text{CS}}$  pin is in the inactive state ( $V_{IH}$ ), the serial interface is ignored. This allows the Host Controller to interface to other SPI devices using the same SDI, SDO, and SCK signals.

### 6.5.5 THE HVC SIGNAL

The HVC pin is compatible with High Voltage commands levels (used with MCP48FEBXX devices).

## 6.6 The SPI Modes

The SPI module supports two (of the four) standard SPI modes. These are Mode 0,0 and 1,1. The SPI mode is determined by the state of the SCK pin ( $V_{IH}$  or  $V_{IL}$ ) when the  $\overline{\text{CS}}$  pin transitions from inactive ( $V_{IH}$ ) to active ( $V_{IL}$ ).

### 6.6.1 MODE 0,0

In **Mode 0,0**:

- SCK idle state = low ( $V_{IL}$ )
- Data is clocked in on the SDI pin on the rising edge of SCK
- Data is clocked out on the SDO pin on the falling edge of SCK

### 6.6.2 MODE 1,1

In **Mode 1,1**:

- SCK idle state = high ( $V_{IH}$ )
- Data is clocked in on the SDI pin on the rising edge of SCK
- Data is clocked out on the SDO pin on the falling edge of SCK

## 7.0 SPI COMMANDS

This section documents the commands that the device supports.

The MCP48FVBXX's SPI command format supports 32 memory address locations and two commands.

The two commands are:

- Write command (C1:C0 = '00')
- Read command (C1:C0 = '11')

The supported commands are shown in [Table 7-1](#). These commands allow for both single data or continuous data operation. [Table 7-1](#) also shows the required number of bit clocks for each command's different mode of operation.

The 24-bit commands (see [Figure 7-1](#)) are used to read and write to the device registers ([Read Command](#) and [Write Command](#)). These commands contain a Command Byte and two Data Bytes.

[Table 7-2](#) shows an overview of all the SPI commands and their interaction with other device features.

**TABLE 7-1: SPI COMMANDS - NUMBER OF CLOCKS**

Operation	Command				# of Bit Clocks <sup>(1)</sup>	Data Update Rate (8-bit/10-bit/12-bit) (Data Words/Second)			Comments
	Code		HV	Mode		@	@	@	
	C1	C0				1 MHz	10 MHz	20 MHz	
Write Command	0	0	No <sup>(2)</sup>	Single	24	41,666	416,666	833,333	
	0	0	No <sup>(2)</sup>	Continuous	24 * n	41,666	416,666	833,333	For 10 data words
Read Command	1	1	No <sup>(2)</sup>	Single	24	41,666	416,666	N.A.	
	1	1	No <sup>(2)</sup>	Continuous	24 * n	41,666	416,666	N.A.	For 10 data words

**Note 1:** "n" indicates the number of times the command operation is to be repeated.

- 2:** If the state of the HVC pin is  $V_{IH}$ , then the command is ignored, but a Command Error condition (CMDERR) will NOT be generated.

# MCP48FVBXX

## 7.0.1 COMMAND BYTE

The Command Byte has three fields: the address, the command, and one data bit (see [Figure 7-1](#)).

The device memory is accessed when the master sends a proper command byte to select the desired operation. The memory location getting accessed is contained in the command byte's AD4:AD0 bits. The action desired is contained in the command byte's C1:C0 bits, see [Table 7-3](#). C1:C0 determines if the desired memory location will be read or written.

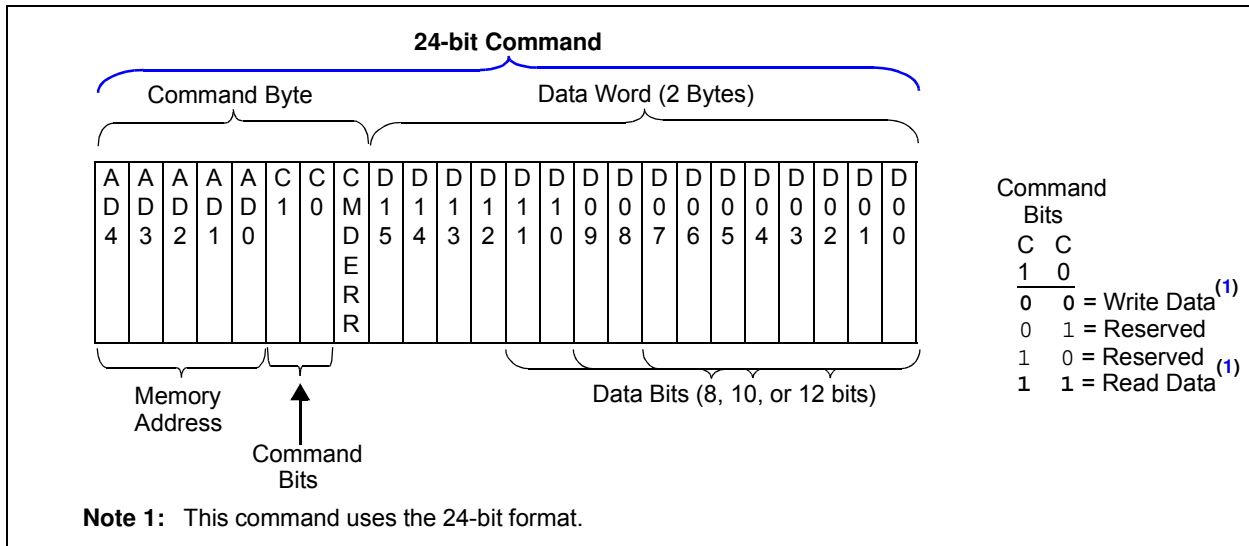
As the command byte is being loaded into the device (on the SDI pin), the device's SDO pin is driving. The SDO pin will output high bits for the first seven bits of that command. On the 8th bit, the SDO pin will output the CMDERR bit state (see [Section 7.0.3, "Error Condition"](#)).

## 7.0.2 DATA BYTES

These commands concatenate the two data bytes after the command byte, for a 24-bit long command (see [Figure 7-1](#)).

**TABLE 7-2: COMMAND BITS OVERVIEW**

C1:C0 bit states	Command	# of Bits	Normal or HV
00	Write Data	24 Bits	Normal
01	Reserved	—	—
10	Reserved	—	—
11	Read Data	24 Bits	Normal



**FIGURE 7-1:** 24-bit SPI Command Format.

## 7.0.3 ERROR CONDITION

The Command Error (CMDERR) bit indicates if the five address bits received (AD4:AD0) and the two command bits received (C1:C0) are a valid combination (see Figure 7-1). The CMDERR bit is high if the combination is valid and low if the combination is invalid.

SPI commands that do not have a multiple of eight clocks are ignored.

Once an error condition has occurred, any following commands are ignored. All following SDO bits will be low until the CMDERR condition is cleared by forcing the CS pin to the inactive state ( $V_{IH}$ ).

### 7.0.3.1 Aborting a Transmission

All SPI transmissions must have the correct number of SCK pulses to be executed. The command is not executed until the complete number of clocks has been received. If the CS pin is forced to the inactive state ( $V_{IH}$ ), the serial interface is reset. Partial commands are not executed.

SPI is more susceptible to noise than other bus protocols. The most likely case is that noise corrupts the value of the data being clocked into the MCP48FVBXX or the SCK pin is injected with extra clock pulses. This may cause data to be corrupted in the device, or a Command Error to occur, since the address and command bits were not a valid combination. The extra SCK pulse will also cause the SPI data (SDI) and clock (SCK) to be out of sync. Forcing the CS pin to the inactive state ( $V_{IH}$ ) resets the serial interface. The MCP48FVBXX's SPI interface will ignore activity on the SDI and SCK pins until the CS pin transition to the active state is detected ( $V_{IH}$  to  $V_{IL}$ ).

**Note 1:** When data is not being received by the MCP48FVBXX, it is recommended that the CS pin be forced to the inactive level ( $V_{IH}$ ).

**2:** It is also recommended that long continuous command strings be broken down into single commands or shorter continuous command strings. This reduces the probability of noise on the SCK pin corrupting the desired SPI commands.

## 7.0.4 CONTINUOUS COMMANDS

The device supports the ability to execute commands continuously. While the CS pin is in the active state ( $V_{IL}$ ), any sequence of valid commands may be received.

The following example is a valid sequence of events:

1. CS pin driven active ( $V_{IL}$ )
2. Read command
3. Write command (Volatile memory)
4. CS pin driven inactive ( $V_{IH}$ )

**Note 1:** It is recommended that while the CS pin is active, only one type of command should be issued. When changing commands, it is advisable to take the CS pin inactive then force it back to the active state.

**2:** It is also recommended that long command strings should be broken down into shorter command strings. This reduces the probability of noise on the SCK pin, corrupting the desired SPI command string.

# MCP48FVBXX

## 7.1 Write Command

Write commands are used to transfer data to the desired memory location (from the Host controller).

Write commands can be structured as either Single or Continuous.

The format of the command is shown in Figures 7-2 (Single) and 7-3 (Continuous).

A write command to a volatile memory location changes that location after a properly formatted write command has been received.

**Note 1:** During device communication, if the Device Address/Command combination is invalid or an unimplemented Device Address is specified, then the MCP48FVBXX will generate a Command Error state. To reset the SPI state machine, the  $\overline{CS}$  pin must transition to the inactive state ( $V_{IH}$ ).

### 7.1.2 CONTINUOUS WRITES TO VOLATILE MEMORY

A continuous write mode of operation is possible when writing to the device's volatile memory registers (see Table 7-3). Figure 7-3 shows the sequence for three continuous writes. The writes do not need to be to the same volatile memory address.

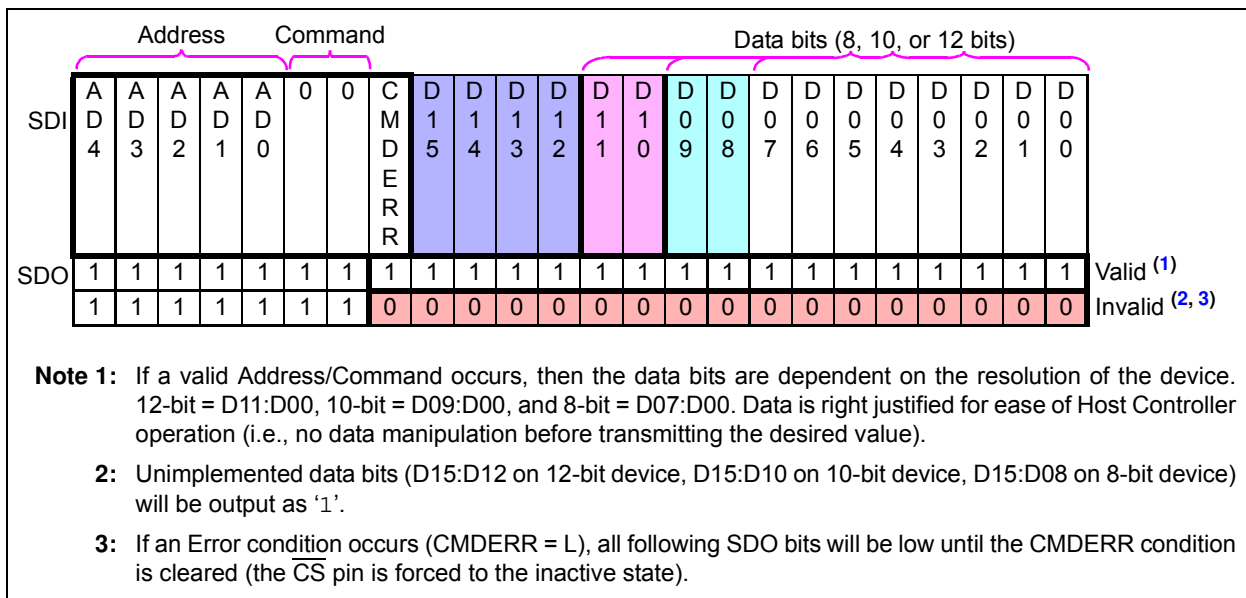
**TABLE 7-3: VOLATILE MEMORY ADDRESSES**

Address	Single-Channel	Dual-Channel
00h	Yes	Yes
01h	No	Yes
08h	Yes	Yes
09h	Yes	Yes
0Ah	Yes	Yes

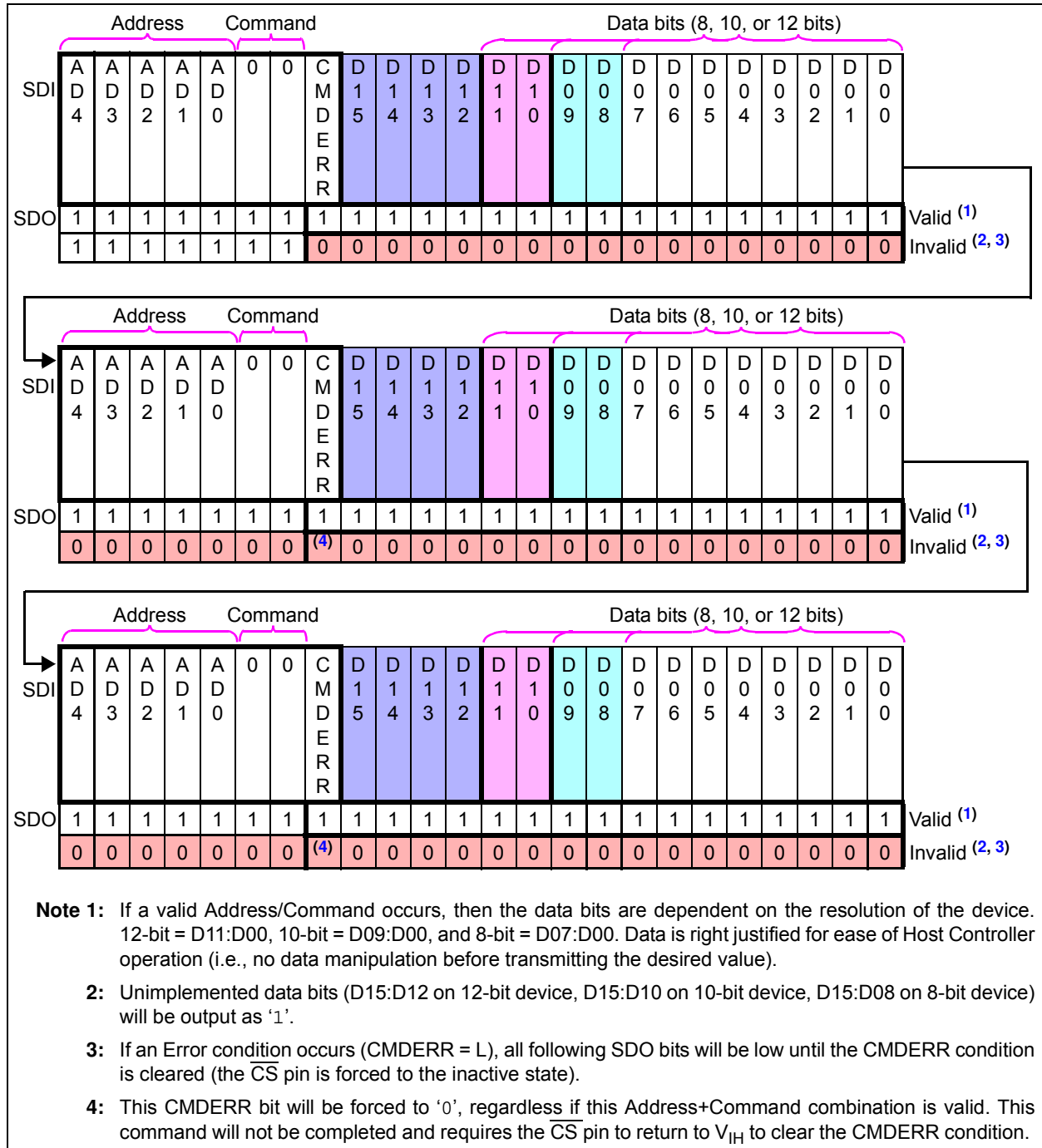
### 7.1.1 SINGLE WRITE TO VOLATILE MEMORY

The write operation requires that the  $\overline{CS}$  pin be in the active state ( $V_{IL}$ ). Typically, the  $\overline{CS}$  pin will be in the inactive state ( $V_{IH}$ ) and is driven to the active state ( $V_{IL}$ ). The 24-bit `write` command (Command Byte and Data Bytes) is then clocked in on the SCK and SDI pins. Once all 24 bits have been received, the specified volatile address is updated. A write will not occur if the `write` command is not exactly 24 clock pulses. This protects against system issues corrupting the volatile memory locations.

Figures 7-4 and 7-5 show the waveforms for a single write (depending on SPI mode).

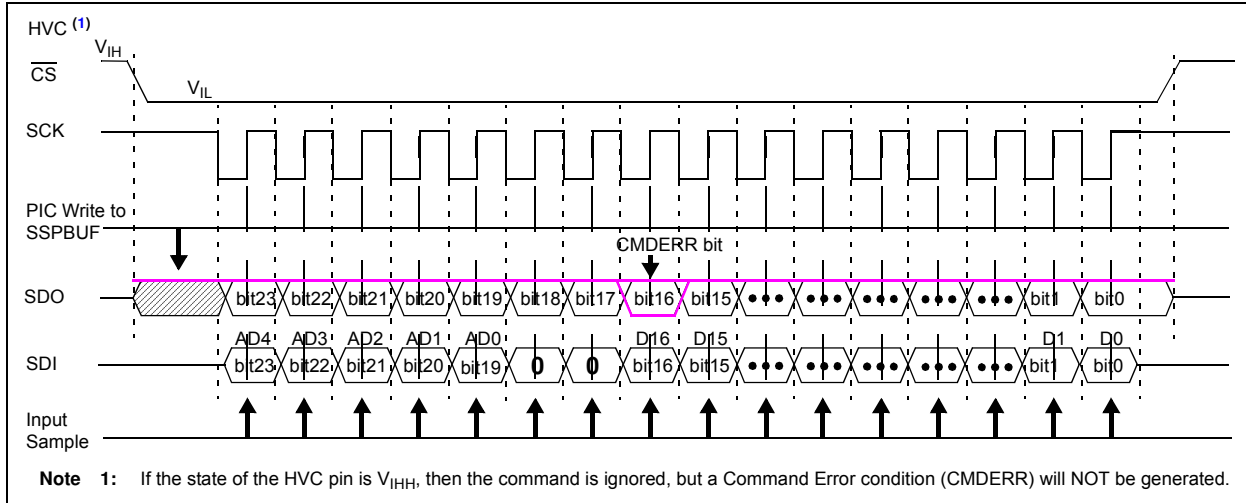


**FIGURE 7-2:** Write Command - SDI and SDO States.

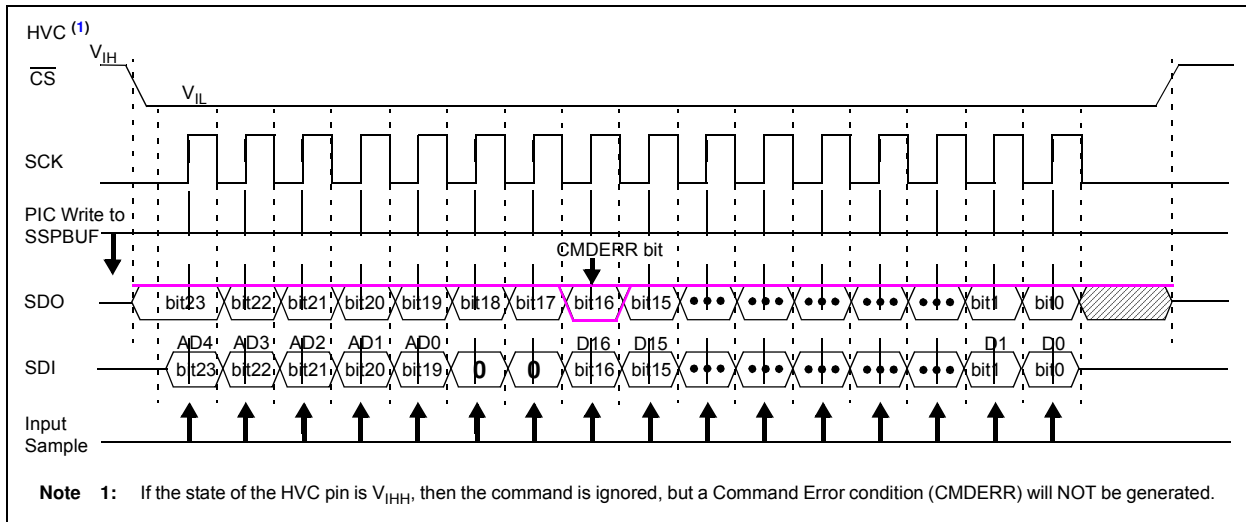


**FIGURE 7-3:** Continuous Write Sequence.

# MCP48FVBXX



**FIGURE 7-4:** 24-Bit Write Command ( $C1:C0 = "00"$ ) - SPI Waveform with PIC MCU (Mode 1,1).



**FIGURE 7-5:** 24-Bit Write Command ( $C1:C0 = "00"$ ) - SPI Waveform with PIC MCU (Mode 0,0).

## 7.2 Read Command

The Read command is a 24-bit command and is used to transfer data from the specified memory location to the Host controller. The Read command can be issued to the volatile memory locations. The format of the command as well as an example SDI and SDO data is shown in Figure 7-6.

The first 7-bits of the Read command determine the address and the command. The 8th clock will output the CMDERR bit on the SDO pin. By means of the remaining 16 clocks, the device will transmit the data bits of the specified address (AD4:AD0).

The Read command formats include:

- Single Read
- Continuous Reads

**Note 1:** During device communication, if the Device Address/Command combination is invalid or an unimplemented Address is specified, then the MCP48FVBXX will command error that byte. To reset the SPI state machine, the  $\overline{CS}$  pin must be driven to the  $V_{IH}$  state.

- 2: If the  $\overline{LAT}$  pin is High ( $V_{IH}$ ), reads of the volatile DAC Register address returns that DAC's output value, not the internal register.
- 3: Read commands ignore any High Voltage Command levels that are present on the HVC pin.

### 7.2.1 $\overline{LAT}$ PIN INTERACTION

During a Read command of the DACx Registers, if the  $\overline{LAT}$  pin transitions from  $V_{IH}$  to  $V_{IL}$ , then the read data may be corrupted. This is due to the fact that the data being read is the output value and not the DAC register value. The  $\overline{LAT}$  pin transition causes an update of the output value. Based on the DAC output value, the DACx register value, and the Command bit where the  $\overline{LAT}$  pin transitions, the value being read could be corrupted.

If  $\overline{LAT}$  pin transitions occur during a read of the DACx register, it is recommended that sequential reads be performed until the two most recent read values match. Then the most recent read data is good.

### 7.2.2 SINGLE READ

The Read command operation requires that the  $\overline{CS}$  pin be in the active state ( $V_{IL}$ ). Typically, the  $\overline{CS}$  pin will be in the inactive state ( $V_{IH}$ ) and is driven to the active state ( $V_{IL}$ ). The 24-bit Read command (Command Byte and Data Byte) is then clocked in on the SCK and SDI pins. The SDO pin starts driving data on the 8th bit (CMDERR bit), and the addressed data comes out on the 9th through 24th clocks.

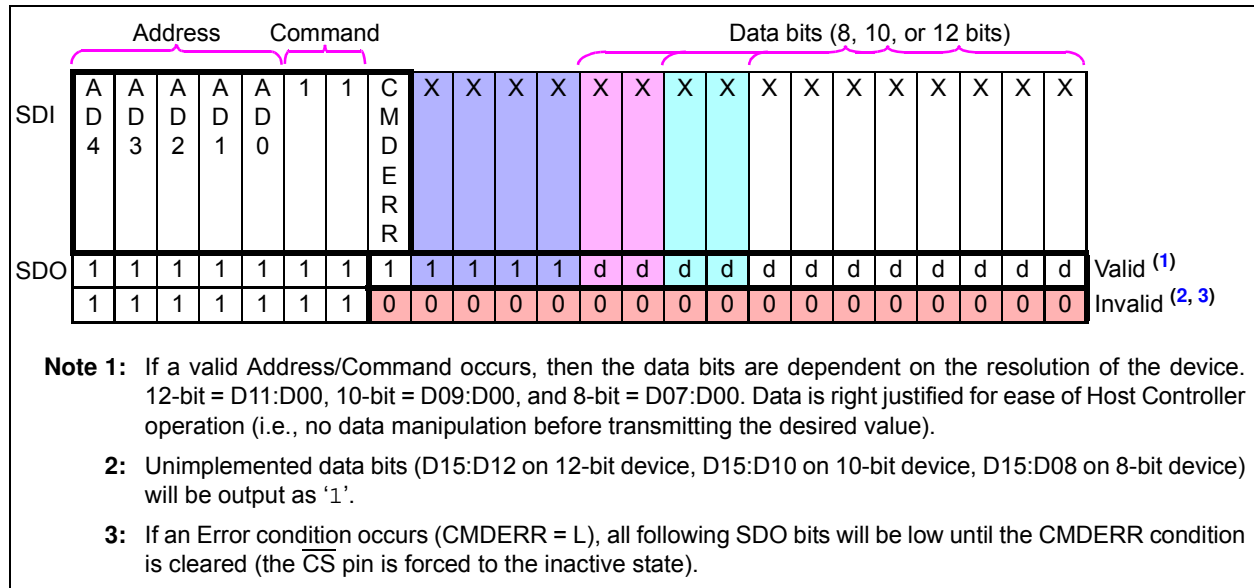


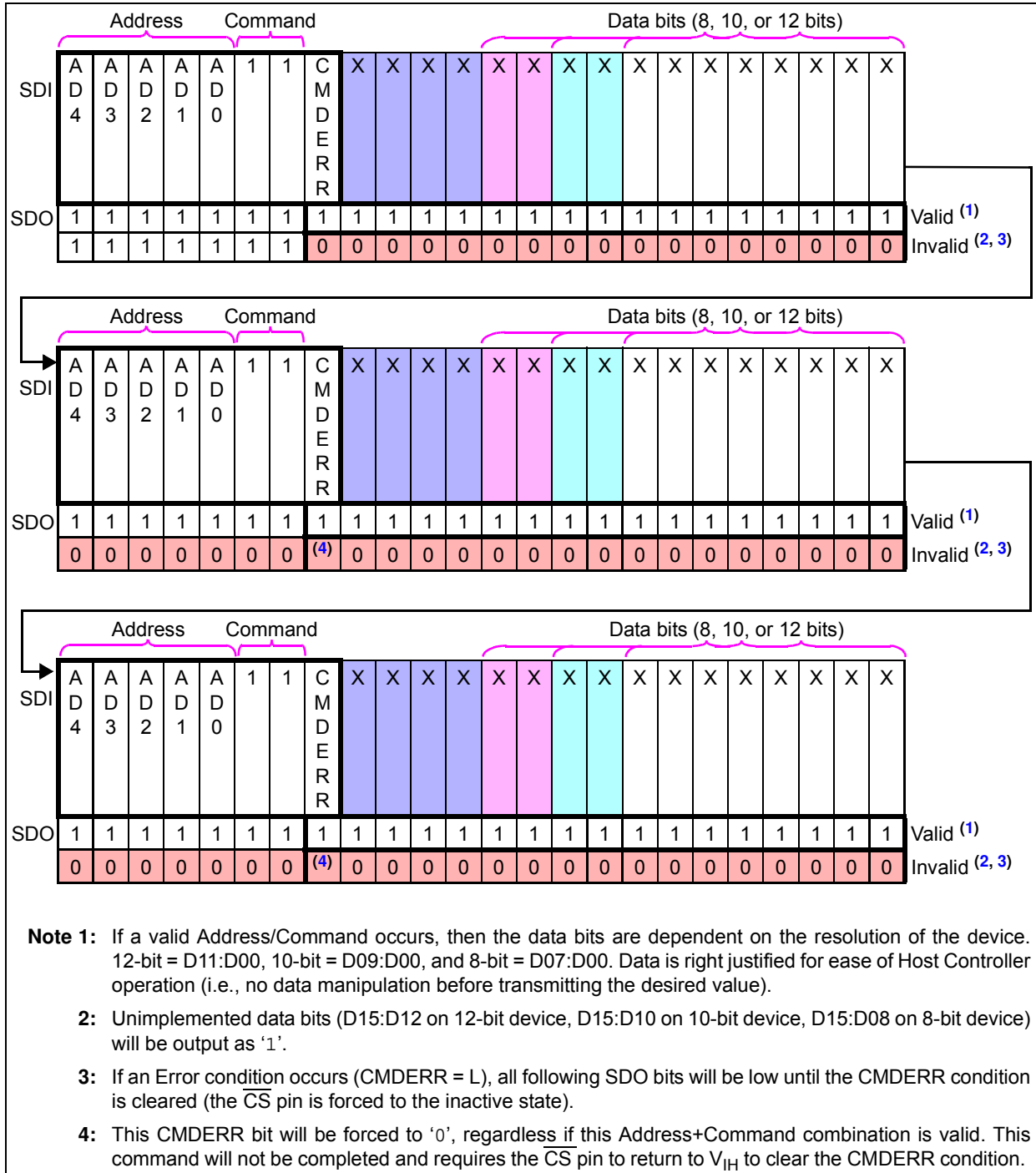
FIGURE 7-6: Read Command - SDI and SDO States.

# MCP48FVBXX

## 7.2.3 CONTINUOUS READS

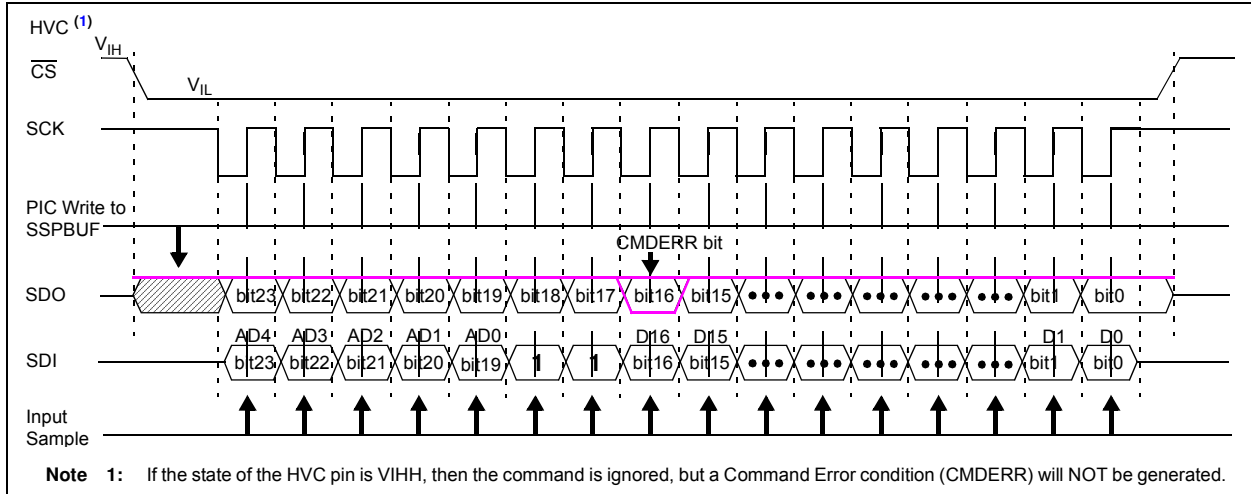
Continuous-reads format allows the device's memory to be read quickly. Continuous reads are possible to all memory locations.

Figure 7-7 shows the sequence for three continuous reads. The reads do not need to be to the same memory address.

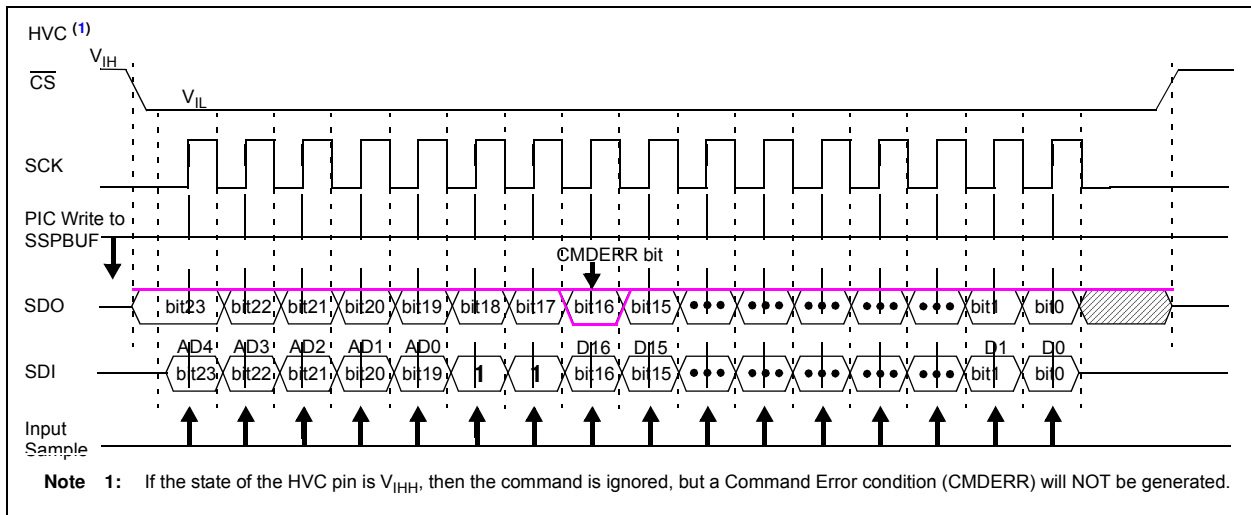


**FIGURE 7-7:** Continuous-Reads Sequence.

# MCP48FVBXX



**FIGURE 7-8:** 24-Bit Read Command ( $C1:C0 = "11"$ ) - SPI Waveform with PIC MCU (Mode 1,1).



**FIGURE 7-9:** 24-Bit Read Command ( $C1:C0 = "11"$ ) - SPI Waveform with PIC MCU (Mode 0,0).

# MCP48FVBXX

---

NOTES:

## 8.0 TYPICAL APPLICATIONS

The MCP48FVBXX devices are general purpose, single/dual-channel voltage output DACs for various applications where a precision operation with low power and volatile memory is needed.

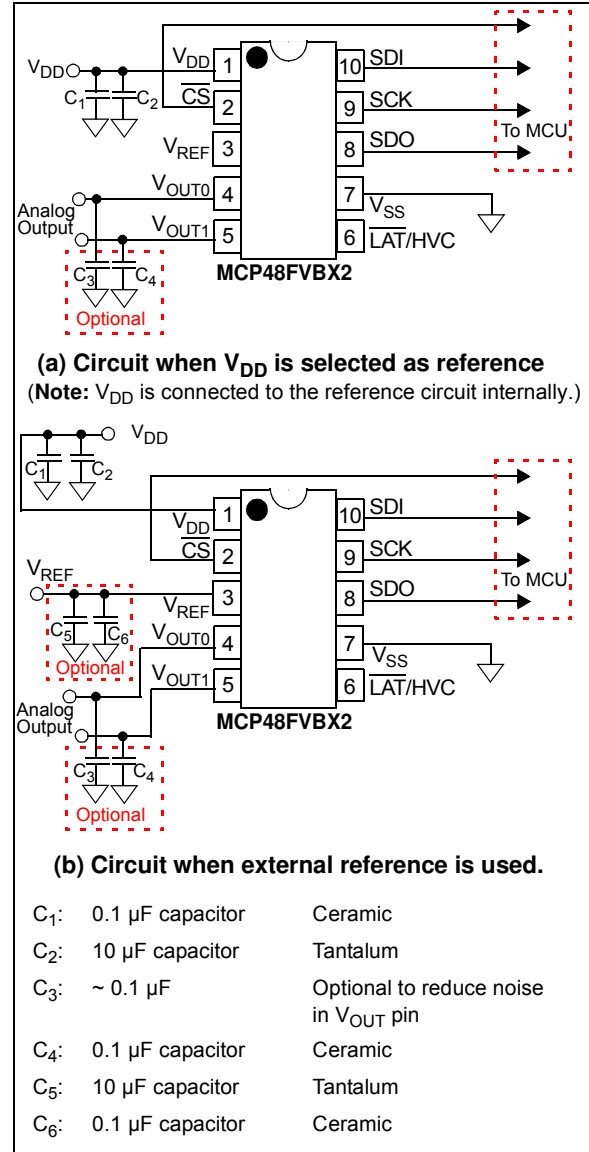
Applications generally suited for the devices are:

- Set Point or Offset Trimming
- Sensor Calibration
- Portable Instrumentation (Battery-Powered)
- Motor Control

## 8.1 Power Supply Considerations

The power source should be as clean as possible. The power supply to the device is also used for the DAC voltage reference internally if the internal  $V_{DD}$  is selected as the resistor ladder's reference voltage ( $VRxB:VRxA = '00'$ ).

Any noise induced on the  $V_{DD}$  line can affect the DAC performance. Typical applications will require a bypass capacitor in order to filter out high-frequency noise on the  $V_{DD}$  line. The noise can be induced onto the power supply's traces or as a result of changes on the DAC output. The bypass capacitor helps to minimize the effect of these noise sources on signal integrity. [Figure 8-1](#) shows an example of using two bypass capacitors (a 10  $\mu F$  tantalum capacitor and a 0.1  $\mu F$  ceramic capacitor) in parallel on the  $V_{DD}$  line. These capacitors should be placed as close to the  $V_{DD}$  pin as possible (within 4 mm). If the application circuit has separate digital and analog power supplies, the  $V_{DD}$  and  $V_{SS}$  pins of the device should reside on the analog plane.



**FIGURE 8-1:** Bypass Filtering Example Circuit.

# MCP48FVBXX

## 8.2 Application Examples

The MCP48FVBXX devices are rail-to-rail output DACs designed to operate with a  $V_{DD}$  range of 2.7V to 5.5V. The internal output operational amplifier is robust enough to drive common, small-signal loads directly, thus eliminating the cost and size of external buffers for most applications. The user can use gain of 1 or 2 of the output operational amplifier by setting the Configuration register bits. Also, the user can use internal  $V_{DD}$  as the reference or use an external reference. Various user options and easy-to-use features make the devices suitable for various modern DAC applications.

Application examples include:

- [Decreasing Output Step Size](#)
- [Building a “Window” DAC](#)
- [Bipolar Operation](#)
- [Selectable Gain and Offset Bipolar Voltage Output](#)
- [Designing a Double-Precision DAC](#)
- [Building Programmable Current Source](#)
- [Serial Interface Communication Times](#)
- [Power Supply Considerations](#)
- [Layout Considerations](#)

### 8.2.1 DC SET POINT OR CALIBRATION

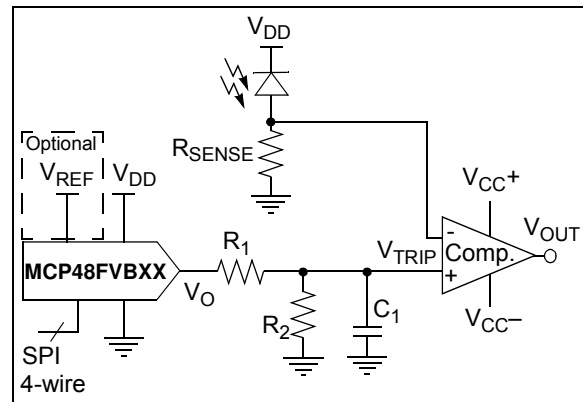
A common application for the devices is a digitally-controlled set point and/or calibration of variable parameters, such as sensor offset or slope. For example, the MCP48FVB2X provides 4096 output steps. If voltage reference is 4.096V (where  $G_x = '0'$ ), the LSB size is 1 mV. If a smaller output step size is desired, a lower external voltage reference is needed.

#### 8.2.1.1 Decreasing Output Step Size

If the application is calibrating the bias voltage of a diode or transistor, a bias voltage range of 0.8V may be desired with about 200  $\mu$ V resolution per step. Two common methods to achieve small step size are:

- **Using lower  $V_{REF}$  pin voltage:** Using an external voltage reference ( $V_{REF}$ ) is an option if the external reference is available with the desired output voltage range. However, occasionally, when using a low-voltage reference voltage, the noise floor causes a SNR error that is intolerable.
- **Using a voltage divider on the DAC's output:** Using a voltage divider provides some advantages when external voltage reference needs to be very low or when the desired output voltage is not available. In this case, a larger value reference voltage is used while two resistors scale the output range down to the precise desired level.

Figure 8-2 illustrates this concept. A bypass capacitor on the output of the voltage divider plays a critical function in attenuating the output noise of the DAC and the induced noise from the environment.



**FIGURE 8-2:** Example Circuit Of Set-Point or Threshold Calibration.

#### EQUATION 8-1: $V_{OUT}$ AND $V_{TRIP}$ CALCULATIONS

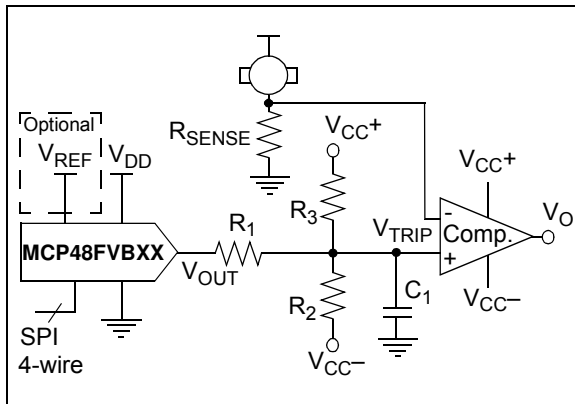
$$V_{OUT} = V_{REF} \cdot G \cdot \frac{\text{DAC Register Value}}{2^N}$$

$$V_{trip} = V_{OUT} \left( \frac{R_2}{R_1 + R_2} \right)$$

## 8.2.1.2 Building a “Window” DAC

When calibrating a set point or threshold of a sensor, typically only a small portion of the DAC output range is utilized. If the LSb size is adequate enough to meet the application’s accuracy needs, the unused range is sacrificed without consequences. If greater accuracy is needed, then the output range will need to be reduced to increase the resolution around the desired threshold.

If the threshold is not near  $V_{REF}$ ,  $2 * V_{REF}$ , or  $V_{SS}$ , then creating a “window” around the threshold has several advantages. One simple method to create this “window” is to use a voltage divider network with a pull-up and pull-down resistor. Figures 8-3 and 8-5 illustrate this concept.



**FIGURE 8-3:** Single-Supply “Window” DAC.

### EQUATION 8-2: $V_{OUT}$ AND $V_{TRIP}$ CALCULATIONS

$$V_{OUT} = V_{REF} \cdot G \cdot \frac{\text{DAC Register Value}}{2^N}$$

$$V_{TRIP} = \frac{V_{OUT}R_{23} + V_{23}R_1}{R_1 + R_{23}}$$

Thevenin Equivalent

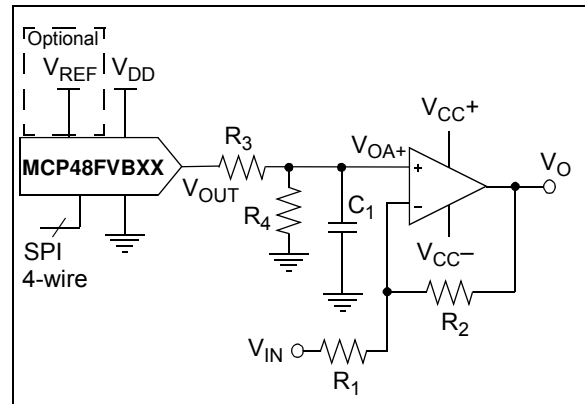
$$R_{23} = \frac{R_2 R_3}{R_2 + R_3}$$

$$V_{23} = \frac{(V_{CC+} R_2) + (V_{CC-} R_3)}{R_2 + R_3}$$

## 8.3 Bipolar Operation

Bipolar operation is achievable by utilizing an external operational amplifier. This configuration is desirable due to the wide variety and availability of op amps. This allows a general purpose DAC, with its cost and availability advantages, to meet almost any desired output voltage range, power and noise performance.

Figure 8-4 illustrates a simple bipolar voltage source configuration.  $R_1$  and  $R_2$  allow the gain to be selected, while  $R_3$  and  $R_4$  shift the DAC’s output to a selected offset. Note that  $R_4$  can be tied to  $V_{DD}$  instead of  $V_{SS}$  if a higher offset is desired.



**FIGURE 8-4:** Digitally-Controlled Bipolar Voltage Source Example Circuit.

### EQUATION 8-3: $V_{OUT}$ , $V_{OA+}$ , AND $V_O$ CALCULATIONS

$$V_{OUT} = V_{REF} \cdot G \cdot \frac{\text{DAC Register Value}}{2^N}$$

$$V_{OA+} = \frac{V_{OUT} \cdot R_4}{R_3 + R_4}$$

$$V_O = V_{OA+} \cdot \left(1 + \frac{R_2}{R_1}\right) - V_{DD} \cdot \left(\frac{R_2}{R_1}\right)$$

# MCP48FVBXX

## 8.4 Selectable Gain and Offset Bipolar Voltage Output

In some applications, precision digital control of the output range is desirable. Figure 8-5 illustrates how to use DAC devices to achieve this in a bipolar or single-supply application.

This circuit is typically used for linearizing a sensor whose slope and offset varies.

The equation to design a bipolar “window” DAC would be utilized if  $R_3$ ,  $R_4$  and  $R_5$  are populated.

### Bipolar DAC Example

An output step size of 1 mV with an output range of  $\pm 2.05V$  is desired for a particular application.

**Step 1:** Calculate the range:  $+2.05V - (-2.05V) = 4.1V$ .

**Step 2:** Calculate the resolution needed:

$$4.1V/1 \text{ mV} = 4100$$

Since  $2^{12} = 4096$ , 12-bit resolution is desired.

**Step 3:** The amplifier gain ( $R_2/R_1$ ), multiplied by full-scale  $V_{OUT}$  (4.096V), must be equal to the desired minimum output to achieve bipolar operation. Since any gain can be realized by choosing resistor values ( $R_1 + R_2$ ), the  $V_{REF}$  value must be selected first. If a  $V_{REF}$  of 4.096V is used, solve for the amplifier's gain by setting the DAC to 0, knowing that the output needs to be -2.05V.

The equation can be simplified to:

### EQUATION 8-4:

$$\frac{-R_2}{R_1} = \frac{-2.05}{4.096V} \quad \frac{R_2}{R_1} = \frac{1}{2}$$

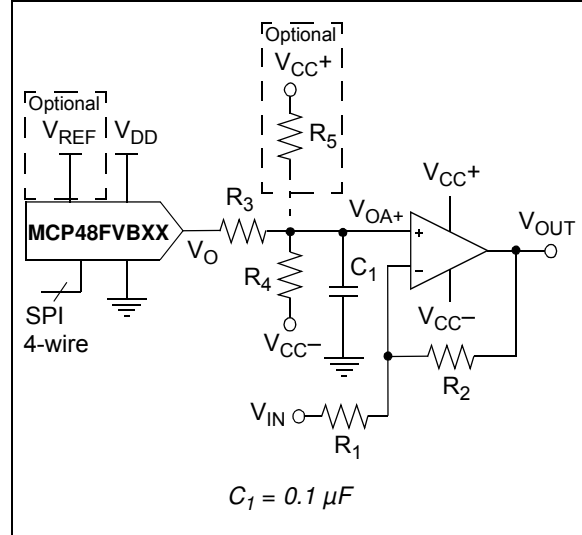
If  $R_1 = 20 \text{ k}\Omega$  and  $R_2 = 10 \text{ k}\Omega$ , the gain will be 0.5.

**Step 4:** Next, solve for  $R_3$  and  $R_4$  by setting the DAC to 4096, knowing that the output needs to be +2.05V.

### EQUATION 8-5:

$$\frac{R_4}{(R_3 + R_4)} = \frac{2.05V + (0.5 \cdot 4.096V)}{1.5 \cdot 4.096V} = \frac{2}{3}$$

If  $R_4 = 20 \text{ k}\Omega$ , then  $R_3 = 10 \text{ k}\Omega$



**FIGURE 8-5:** Bipolar Voltage Source with Selectable Gain and Offset.

### EQUATION 8-6: $V_{OUT}$ , $V_{OA+}$ , AND $V_O$ CALCULATIONS

$$V_{OUT} = V_{REF} \cdot G \cdot \frac{\text{DAC Register Value}}{2^N}$$

$$V_{OA+} = \frac{V_{OUT} \cdot R_4 + V_{CC-} \cdot R_5}{R_3 + R_4}$$

$$V_O = \underbrace{V_{OA+} \cdot \left(1 + \frac{R_2}{R_1}\right)}_{\text{Offset Adjust}} - \underbrace{V_{IN} \cdot \left(\frac{R_2}{R_1}\right)}_{\text{Gain Adjust}}$$

### EQUATION 8-7: BIPOLAR “WINDOW” DAC USING $R_4$ AND $R_5$

$$\text{Thevenin Equivalent} \left\{ \begin{aligned} V_{45} &= \frac{V_{CC+} R_4 + V_{CC-} R_5}{R_4 + R_5} \end{aligned} \right.$$

$$V_{IN+} = \frac{V_{OUT} R_{45} + V_{45} R_3}{R_3 + R_{45}}$$

$$R_{45} = \frac{R_4 R_5}{R_4 + R_5}$$

$$V_O = \underbrace{V_{IN+} \left(1 + \frac{R_2}{R_1}\right)}_{\text{Offset Adjust}} - \underbrace{V_A \left(\frac{R_2}{R_1}\right)}_{\text{Gain Adjust}}$$

## 8.5 Designing a Double-Precision DAC

Figure 8-6 shows an example design of a single-supply voltage output capable of up to 24-bit resolution. This requires two 12-bit DACs. This design is simply a voltage divider with a buffered output.

### Double-Precision DAC Example

If a similar application to the one developed in [Bipolar DAC Example](#) required a resolution of 1  $\mu\text{V}$  instead of 1 mV and a range of 0V to 4.1V, then 12-bit resolution would not be adequate.

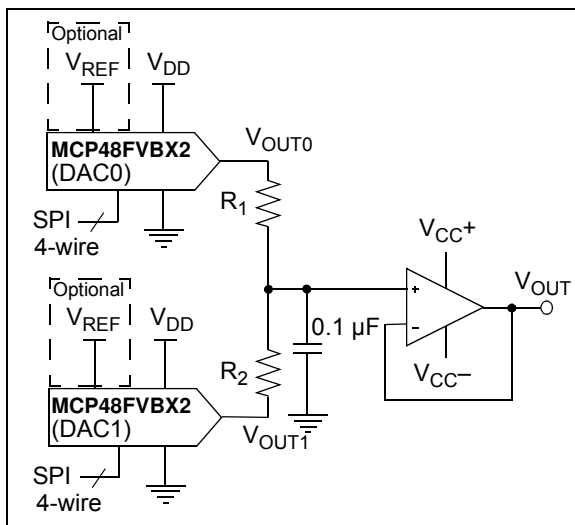
**Step 1:** Calculate the resolution needed:

$4.1\text{V}/1 \mu\text{V} = 4.1 \times 10^6$ .  
 Since  $2^{22} = 4.2 \times 10^6$ , 22-bit resolution is desired. Since  $\text{DNL} = \pm 1.0 \text{LSb}$ , this design can be attempted with the 12-bit DAC.

**Step 2:** Since DAC1's  $V_{\text{OUT}1}$  has a resolution of 1 mV, its output only needs to be "pulled" 1/1000 to meet the 1  $\mu\text{V}$  target. Dividing  $V_{\text{OUT}0}$  by 1000 would allow the application to compensate for DAC1's DNL error.

**Step 3:** If  $R_2$  is 100 $\Omega$ , then  $R_1$  needs to be 100 k $\Omega$ .

**Step 4:** The resulting transfer function is shown in [Equation 8-8](#).



**FIGURE 8-6:** Simple Double-Precision DAC using MCP48FVBX2.

### EQUATION 8-8: $V_{\text{OUT}}$ CALCULATION

$$V_{\text{OUT}} = \frac{V_{\text{OUT}0} \cdot R_2 + V_{\text{OUT}1} \cdot R_1}{R_1 + R_2}$$

Where:

$$V_{\text{OUT}0} = (V_{\text{REF}} \cdot G \cdot \text{DAC0 Register Value})/4096$$

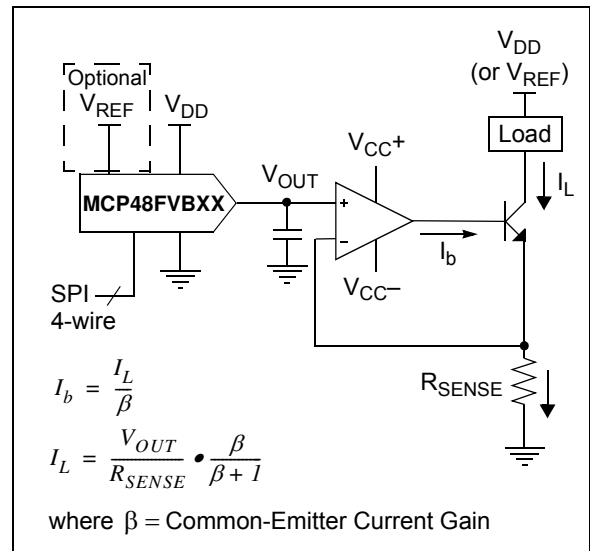
$$V_{\text{OUT}1} = (V_{\text{REF}} \cdot G \cdot \text{DAC1 Register Value})/4096$$

$G_x$  = Selected Op Amp Gain

## 8.6 Building Programmable Current Source

Figure 8-7 shows an example of building a programmable current source using a voltage follower. The current sensor resistor is used to convert the DAC voltage output into a digitally-selectable current source.

The smaller  $R_{\text{SENSE}}$  is, the less power dissipated across it. However, this also reduces the resolution that the current can be controlled.



**FIGURE 8-7:** Digitally-Controlled Current Source.

# MCP48FVBXX

## 8.7 Serial Interface Communication Times

Table 8-1 shows time/frequency of the supported operations of the SPI serial interface for the different serial interface operational frequencies. This, along with the  $V_{OUT}$  output performance (such as slew rate), would be used to determine your application's volatile DAC register update rate.

**TABLE 8-1: SERIAL INTERFACE TIMES / FREQUENCIES**

Command			# of Bit Clocks <sup>(1)</sup>	Data Update Rate (8-bit/10-bit/12-bit) (Data Words/Second)			Comments	
Operation	Code			Mode	1 MHz	10 MHz		20 MHz <sup>(2)</sup>
	C 1	C 0						
Write Command	0	0	Single	24	41,666	416,666	833,333	
	0	0	Continuous	24 * n	41,666	416,666	833,333	For 10 data words
Read Command	1	1	Single	24	41,666	416,666	N.A.	
	1	1	Continuous	24 * n	41,666	416,666	N.A.	For 10 data words

**Note 1:** "n" indicates the number of times the command operation is to be repeated.

**2:** Write command only.

## 8.8 Design Considerations

In the design of a system with the MCP48FVBXX devices, the following considerations should be taken into account:

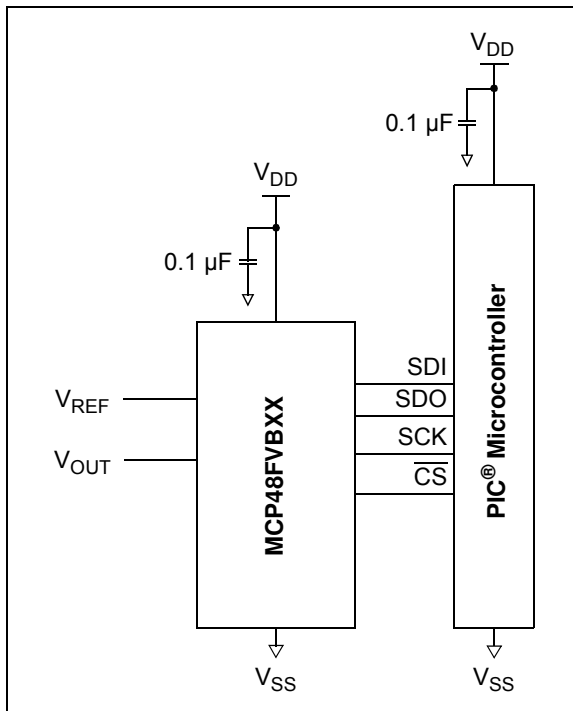
- **Power Supply Considerations**
- **Layout Considerations**

### 8.8.1 POWER SUPPLY CONSIDERATIONS

The typical application will require a bypass capacitor in order to filter high-frequency noise which can be induced onto the power supply's traces. The bypass capacitor helps to minimize the effect of noise sources on signal integrity. [Figure 8-8](#) illustrates an appropriate bypass strategy.

In this example, the recommended bypass capacitor value is 0.1  $\mu\text{F}$ . This capacitor should be placed as close (within 4 mm) to the device power pin ( $V_{\text{DD}}$ ) as possible.

The power source supplying these devices should be as clean as possible. If the application circuit has separate digital and analog power supplies,  $V_{\text{DD}}$  and  $V_{\text{SS}}$  should reside on the analog plane.



**FIGURE 8-8:** Typical Microcontroller Connections.

### 8.8.2 LAYOUT CONSIDERATIONS

Several layout considerations may be applicable to your application. These may include:

- **Noise**
- **PCB Area Requirements**

#### 8.8.2.1 Noise

Inductively-coupled AC transients and digital switching noise can degrade the input and output signal integrity, potentially masking the MCP48FVBXX's performance. Careful board layout minimizes these effects and increases the Signal-to-Noise Ratio (SNR). Multi-layer boards utilizing a low-inductance ground plane, isolated inputs, isolated outputs and proper decoupling are critical to achieving the performance that the silicon is capable of providing. Particularly harsh environments may require shielding of critical signals.

Separate digital and analog ground planes are recommended. In this case, the  $V_{\text{SS}}$  pin and the ground pins of the  $V_{\text{DD}}$  capacitors should be terminated to the analog ground plane.

**Note:** Breadboards and wire-wrapped boards are not recommended.

#### 8.8.2.2 PCB Area Requirements

In some applications, PCB area is a criteria for device selection. [Table 8-2](#) shows the typical package dimensions and area for the 10-lead MSOP package.

**TABLE 8-2: PACKAGE FOOTPRINT <sup>(1)</sup>**

Package			Package Footprint		
Pins	Type	Code	Dimensions (mm)		Area (mm <sup>2</sup> )
			Length	Width	
10	MSOP	UN	3.00	4.90	14.70

**Note 1:** Does not include recommended land pattern dimensions. Dimensions are typical values.

# MCP48FVBXX

---

NOTES:

## 9.0 DEVELOPMENT SUPPORT

Development support can be classified into two groups. These are:

- [Development Tools](#)
- [Technical Documentation](#)

### 9.1 Development Tools

The MCP48FVBXX devices currently do not have any development tools or bond-out boards. Please visit the Device's web product page (Development Tools tab) for the development tools availability after the release of this data sheet.

### 9.2 Technical Documentation

Several additional technical documents are available to assist you in your design and development. These technical documents include Application Notes, Technical Briefs, and Design Guides. [Table 9-1](#) lists some of these documents.

**TABLE 9-1: TECHNICAL DOCUMENTATION**

Application Note Number	Title	Literature #
AN1326	Using the MCP4728 12-Bit DAC for LDMOS Amplifier Bias Control Applications	DS01326
—	Signal Chain Design Guide	DS21825
—	Analog Solutions for Automotive Applications Design Guide	DS01005

# MCP48FVBXX

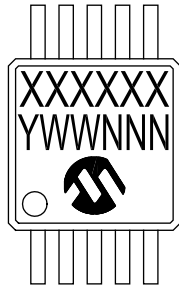
---

NOTES:

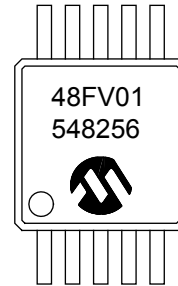
## 10.0 PACKAGING INFORMATION

### 10.1 Package Marking Information

10-Lead MSOP



Example



Device Number	Code	Device Number	Code
MCP48FVB01-E/UN	48FV01	MCP48FVB02-E/UN	48FV02
MCP48FVB01T-E/UN	48FV01	MCP48FVB02T-E/UN	48FV02
MCP48FVB11-E/UN	48FV11	MCP48FVB12-E/UN	48FV12
MCP48FVB11T-E/UN	48FV11	MCP48FVB12T-E/UN	48FV12
MCP48FVB21-E/UN	48FV21	MCP48FVB22-E/UN	48FV22
MCP48FVB21T-E/UN	48FV21	MCP48FVB22T-E/UN	48FV22

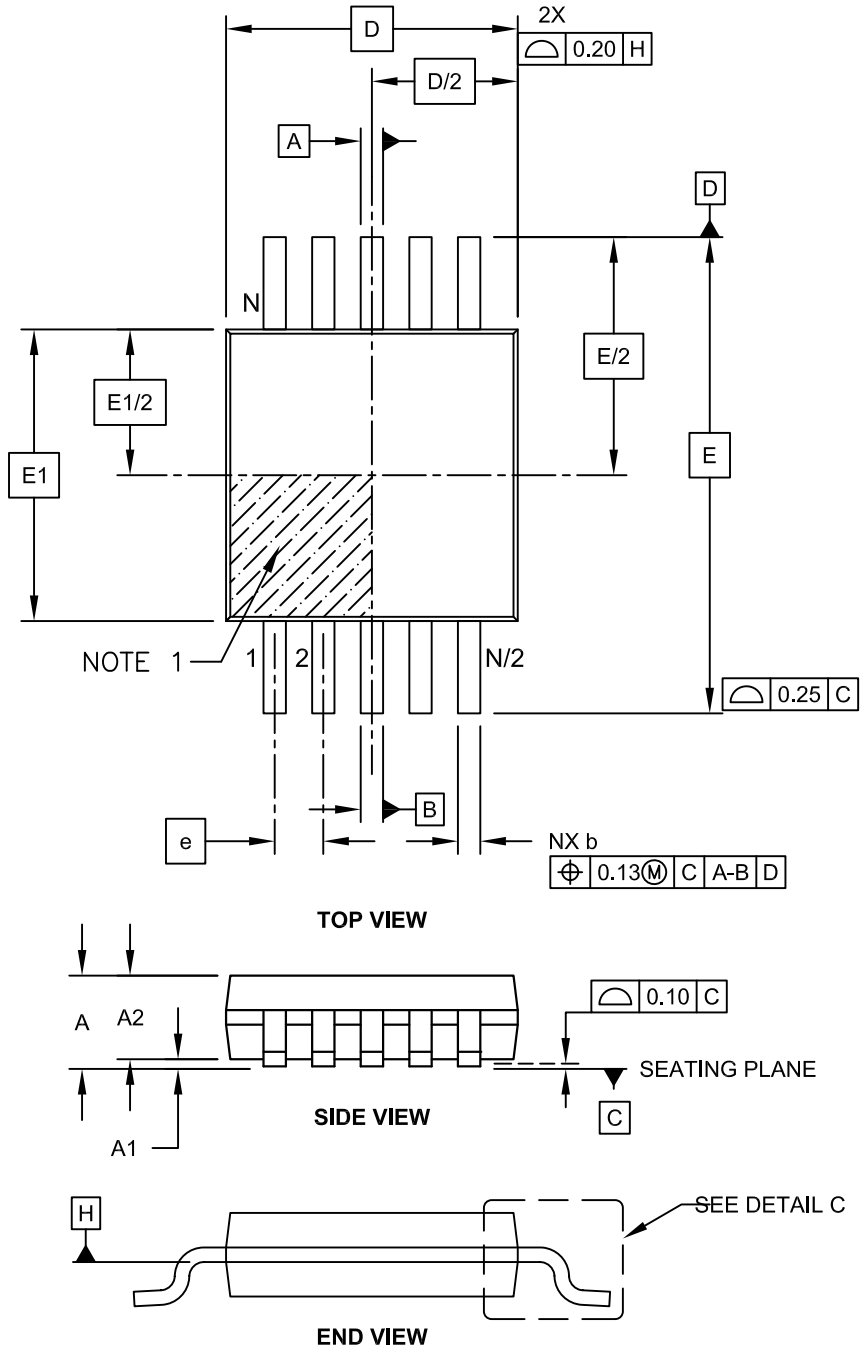
<b>Legend:</b>	XX...X	Customer-specific information
	Y	Year code (last digit of calendar year)
	YY	Year code (last 2 digits of calendar year)
	WW	Week code (week of January 1 is week '01')
	NNN	Alphanumeric traceability code
	(e3)	Pb-free JEDEC® designator for Matte Tin (Sn)
	*	This package is Pb-free. The Pb-free JEDEC designator (e3) can be found on the outer packaging for this package.

**Note:** In the event the full Microchip part number cannot be marked on one line, it will be carried over to the next line, thus limiting the number of available characters for customer-specific information.

# MCP48FVBXX

## 10-Lead Plastic Micro Small Outline Package (UN) [MSOP]

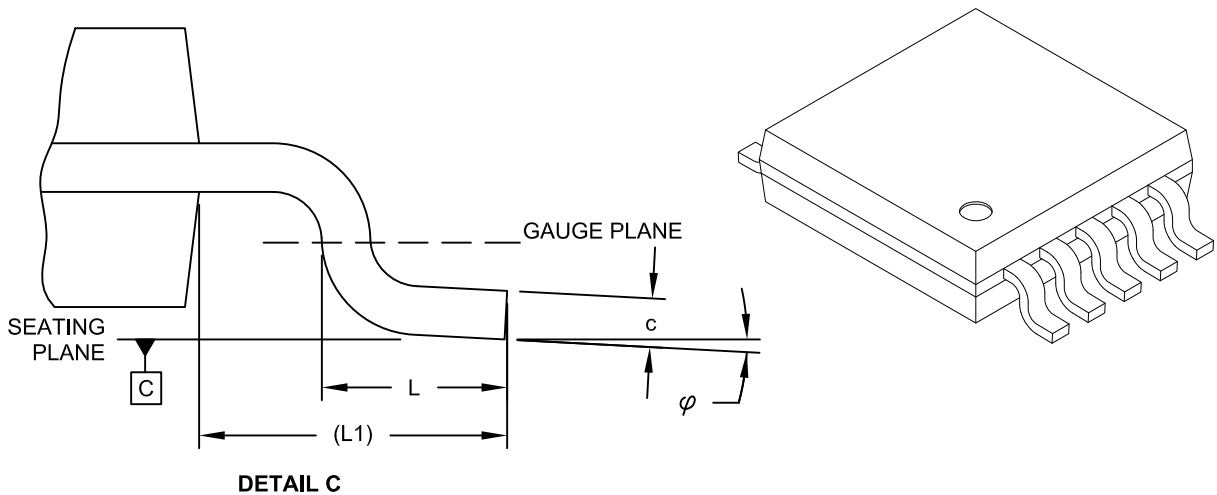
**Note:** For the most current package drawings, please see the Microchip Packaging Specification located at <http://www.microchip.com/packaging>



Microchip Technology Drawing C04-021C Sheet 1 of 2

## 10-Lead Plastic Micro Small Outline Package (UN) [MSOP]

**Note:** For the most current package drawings, please see the Microchip Packaging Specification located at <http://www.microchip.com/packaging>



		Units	MILLIMETERS		
Dimension Limits			MIN	NOM	MAX
Number of Pins	N		10		
Pitch	e		0.50 BSC		
Overall Height	A		-	-	1.10
Molded Package Thickness	A2		0.75	0.85	0.95
Standoff	A1		0.00	-	0.15
Overall Width	E		4.90 BSC		
Molded Package Width	E1		3.00 BSC		
Overall Length	D		3.00 BSC		
Foot Length	L		0.40	0.60	0.80
Footprint	L1		0.95 REF		
Foot Angle	φ		0°	-	8°
Lead Thickness	c		0.08	-	0.23
Lead Width	b		0.15	-	0.33

**Notes:**

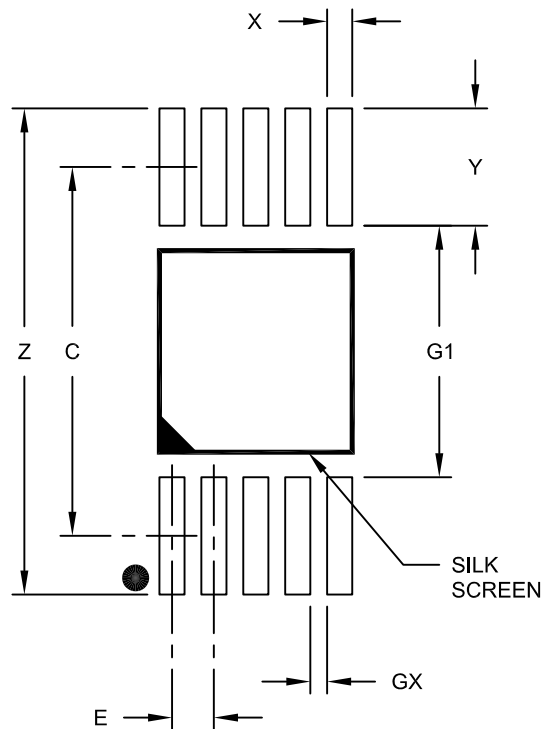
- Pin 1 visual index feature may vary, but must be located within the hatched area.
- Dimensions D and E1 do not include mold flash or protrusions. Mold flash or protrusions shall not exceed 0.15mm per side.
- Dimensioning and tolerancing per ASME Y14.5M.  
 BSC: Basic Dimension. Theoretically exact value shown without tolerances.  
 REF: Reference Dimension, usually without tolerance, for information purposes only.

Microchip Technology Drawing C04-021C Sheet 2 of 2

# MCP48FVBXX

## 10-Lead Plastic Micro Small Outline Package (UN) [MSOP]

**Note:** For the most current package drawings, please see the Microchip Packaging Specification located at <http://www.microchip.com/packaging>



RECOMMENDED LAND PATTERN

Dimension Limits	Units	MILLIMETERS		
		MIN	NOM	MAX
Contact Pitch	E	0.50 BSC		
Contact Pad Spacing	C	4.40		
Overall Width	Z			5.80
Contact Pad Width (X10)	X1			0.30
Contact Pad Length (X10)	Y1			1.40
Distance Between Pads	G1	3.00		
Distance Between Pads	GX	0.20		

**Notes:**

1. Dimensioning and tolerancing per ASME Y14.5M

BSC: Basic Dimension. Theoretically exact value shown without tolerances.

Microchip Technology Drawing No. C04-2021A

## APPENDIX A: REVISION HISTORY

### Revision A (December 2015)

- Original release of this document.

# MCP48FVBXX

## APPENDIX B: TERMINOLOGY

### B.1 Resolution

Resolution is the number of DAC output states that divide the full-scale range. For the 12-bit DAC, the resolution is  $2^{12}$ , meaning the DAC code ranges from 0 to 4095.

**Note:** When there are  $2^N$  resistors in the resistor ladder and  $2^N$  tap points, the full-scale DAC register code is the resistor element (1 LSb) from the source reference voltage ( $V_{DD}$  or  $V_{REF}$ ).

### B.2 Least Significant Bit (LSb)

This is the voltage difference between two successive codes. For a given output voltage range, it is divided by the resolution of the device (Equation B-1). The range may be  $V_{DD}$  (or  $V_{REF}$ ) to  $V_{SS}$  (ideal), the DAC register codes across the linear range of the output driver (Measured 1), or full-scale to zero-scale (Measured 2).

#### EQUATION B-1: LSb VOLTAGE CALCULATION

**Ideal**  

$$V_{LSb(IDEAL)} = \frac{V_{DD}}{2^N} \text{ or } \frac{V_{REF}}{2^N}$$

**Measured 1**  

$$V_{LSb(Measured)} = \frac{V_{OUT(@4000)} - V_{OUT(@100)}}{(4000 - 100)}$$

**Measured 2**  

$$V_{LSb} = \frac{V_{OUT(@FS)} - V_{OUT(@ZS)}}{2^N - 1}$$

$2^N = 4096$  (MCP48FXB2X)  
 $= 1024$  (MCP48FXB1X)  
 $= 256$  (MCP48FXB0X)

### B.3 Monotonic Operation

Monotonic operation means that the device's output voltage ( $V_{OUT}$ ) increases with every 1 code step (LSb) increment (from  $V_{SS}$  to the DAC's reference voltage ( $V_{DD}$  or  $V_{REF}$ )).

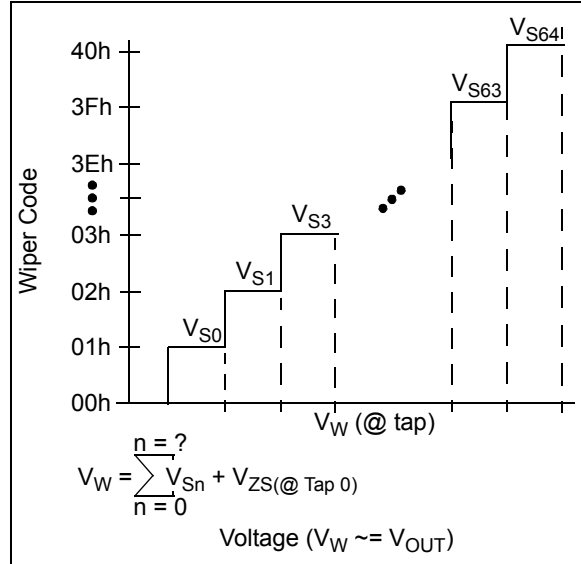


FIGURE B-1:  $V_W$  ( $V_{OUT}$ ).

## B.4 Full-Scale Error ( $E_{FS}$ )

The Full-Scale Error (see [Figure B-3](#)) is the error on the  $V_{OUT}$  pin relative to the expected  $V_{OUT}$  voltage (theoretical) for the maximum device DAC register code (code FFFh for 12-bit, code 3FFh for 10-bit, and code FFh for 8-bit) (see [Equation B-2](#)). The error is dependent on the resistive load on the  $V_{OUT}$  pin (and where that load is tied to, such as  $V_{SS}$  or  $V_{DD}$ ). For loads (to  $V_{SS}$ ) greater than specified, the full-scale error will be greater.

The error in bits is determined by the theoretical voltage step size to give an error in LSb.

### EQUATION B-2: FULL-SCALE ERROR

$$E_{FS} = \frac{V_{OUT(@FS)} - V_{IDEAL(@FS)}}{V_{LSb(IDEAL)}}$$

Where:

$E_{FS}$  is expressed in LSb.

$V_{OUT(@FS)}$  = The  $V_{OUT}$  voltage when the DAC register code is at full-scale.

$V_{IDEAL(@FS)}$  = The ideal output voltage when the DAC register code is at full-scale.

$V_{LSb(IDEAL)}$  = The theoretical voltage step size.

## B.5 Zero-Scale Error ( $E_{ZS}$ )

The Zero-Scale Error (see [Figure B-2](#)) is the difference between the ideal and the measured  $V_{OUT}$  voltage with the DAC register code equal to 000h ([Equation B-3](#)). The error is dependent on the resistive load on the  $V_{OUT}$  pin (and where that load is tied to, such as  $V_{SS}$  or  $V_{DD}$ ). For loads (to  $V_{DD}$ ) greater than specified, the zero-scale error will be greater.

The error in bits is determined by the theoretical voltage step size to give an error in LSb.

### EQUATION B-3: ZERO-SCALE ERROR

$$E_{ZS} = \frac{V_{OUT(@ZS)}}{V_{LSb(IDEAL)}}$$

Where:

$E_{ZS}$  is expressed in LSb.

$V_{OUT(@ZS)}$  = The  $V_{OUT}$  voltage when the DAC register code is at zero-scale.

$V_{LSb(IDEAL)}$  = The theoretical voltage step size.

## B.6 Total Unadjusted Error ( $E_T$ )

The Total Unadjusted Error ( $E_T$ ) is the difference between the ideal and measured  $V_{OUT}$  voltage. Typically, calibration of the output voltage is implemented to improve system performance.

The error in bits is determined by the theoretical voltage step size to give an error in LSb.

[Equation B-4](#) shows the Total Unadjusted Error calculation.

### EQUATION B-4: TOTAL UNADJUSTED ERROR CALCULATION

$$E_T = \frac{(V_{OUT\_Actual(@code)} - V_{OUT\_Ideal(@Code)})}{V_{LSb(Ideal)}}$$

Where:

$E_T$  is expressed in LSb.

$V_{OUT\_Actual(@code)}$  = The measured DAC output voltage at the specified code.

$V_{OUT\_Ideal(@code)}$  = The calculated DAC output voltage at the specified code.  
(code \*  $V_{LSb(Ideal)}$ )

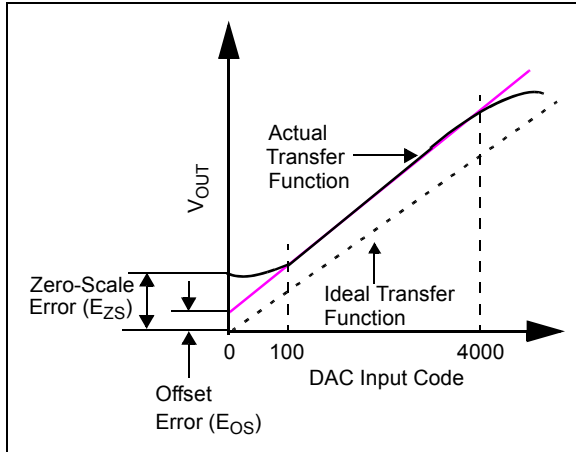
$V_{LSb(Ideal)}$  =  $V_{REF}/\# \text{ Steps}$   
 12-bit =  $V_{REF}/4096$   
 10-bit =  $V_{REF}/1024$   
 8-bit =  $V_{REF}/256$

# MCP48FVBXX

## B.7 Offset Error ( $E_{OS}$ )

The offset error is the delta voltage of the  $V_{OUT}$  voltage from the ideal output voltage at the specified code. This code is specified where the output amplifier is in the linear operating range; for the MCP48FVBXX we specify code 100 (decimal). Offset error does not include gain error. Figure B-2 illustrates this.

This error is expressed in mV. Offset error can be negative or positive. The offset error can be calibrated by software in application circuits.



**FIGURE B-2: OFFSET ERROR AND ZERO-SCALE ERROR.**

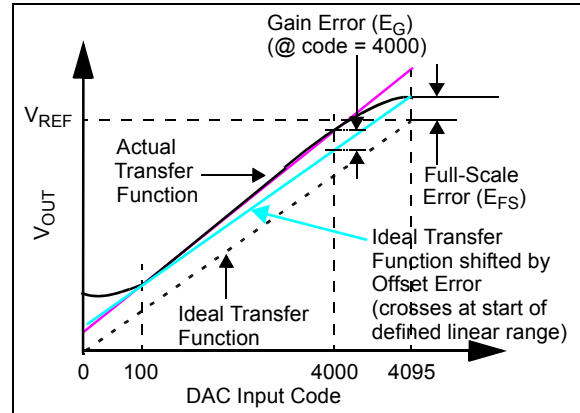
## B.8 Offset Error Drift ( $E_{OSD}$ )

Offset error drift is the variation in offset error due to a change in ambient temperature. Offset error drift is typically expressed in ppm/°C or  $\mu V/^\circ C$ .

## B.9 Gain Error ( $E_G$ )

Gain error is a calculation based on the ideal slope using the voltage boundaries for the linear range of the output driver (ex code 100 and code 4000) (see Figure B-3). The gain error calculation nullifies the device's offset error.

Gain error indicates how well the slope of the actual transfer function matches the slope of the ideal transfer function. Gain error is usually expressed as percent of full-scale range (% of FSR) or in LSB. FSR is the ideal full-scale voltage of the DAC (see Equation B-5).



**FIGURE B-3: GAIN ERROR AND FULL-SCALE ERROR EXAMPLE.**

## EQUATION B-5: EXAMPLE GAIN ERROR

$$E_G = \frac{(V_{OUT(@4000)} - V_{OS} - V_{OUT\_Ideal(@4000)})}{V_{Full-Scale\ Range}} \cdot 100$$

Where:

$E_G$  is expressed in % of full-scale range (FSR).

$V_{OUT(@4000)}$  = The measured DAC output voltage at the specified code.

$V_{OUT\_Ideal(@4000)}$  = The calculated DAC output voltage at the specified code. ( $4000 \cdot V_{LSb(Ideal)}$ )

$V_{OS}$  = Measured offset voltage.

$V_{Full\ Scale\ Range}$  = Expected full-scale output value (such as the  $V_{REF}$  voltage).

## B.10 Gain-Error Drift ( $E_{GD}$ )

Gain-error drift is the variation in gain error due to a change in ambient temperature. Gain error drift is typically expressed in ppm/°C (of full-scale range).

## B.11 Integral Nonlinearity (INL)

The Integral Nonlinearity (INL) error is the maximum deviation of an actual transfer function from an ideal transfer function (straight line) passing through the defined end points of the DAC transfer function (after offset and gain errors have been removed).

In the MCP48FVBXX, INL is calculated using the defined end points, DAC code 100 and code 4000. INL can be expressed as a percentage of full-scale range (FSR) or in LSb. INL is also called Relative Accuracy. Equation B-6 shows how to calculate the INL error in LSb and Figure B-4 shows an example of INL accuracy.

Positive INL means higher  $V_{OUT}$  voltage than ideal. Negative INL means lower  $V_{OUT}$  voltage than ideal.

### EQUATION B-6: INL ERROR

$$E_{INL} = \frac{(V_{OUT} - V_{Calc\_Ideal})}{V_{LSb(Measured)}}$$

Where:

$E_{INL}$  is expressed in LSb.

$$V_{Calc\_Ideal} = Code * V_{LSb(Measured)} + V_{OS}$$

$V_{OUT(Code = n)}$  = The measured DAC output voltage with a given DAC register code

$V_{LSb(Measured)}$  = For Measured:  
 $(V_{OUT(4000)} - V_{OUT(100)})/3900$

$V_{OS}$  = Measured offset voltage.

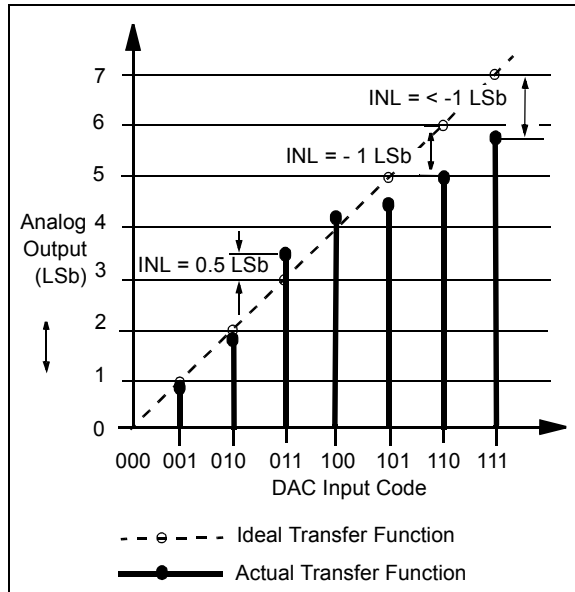


FIGURE B-4: INL ACCURACY.

## B.12 Differential Nonlinearity (DNL)

The Differential Nonlinearity (DNL) error (see Figure B-5) is the measure of step size between codes in actual transfer function. The ideal step size between codes is 1 LSb. A DNL error of zero would imply that every code is exactly 1 LSb wide. If the DNL error is less than 1 LSb, the DAC guarantees monotonic output and no missing codes. Equation B-7 shows how to calculate the DNL error between any two adjacent codes in LSb.

### EQUATION B-7: DNL ERROR

$$E_{DNL} = \frac{(V_{OUT(code = n+1)} - V_{OUT(code = n)})}{V_{LSb(Measured)}} - 1$$

Where:

$E_{DNL}$  is expressed in LSb.

$V_{OUT(Code = n)}$  = The measured DAC output voltage with a given DAC register code.

$V_{LSb(Measured)}$  = For Measured:  
 $(V_{OUT(4000)} - V_{OUT(100)})/3900$

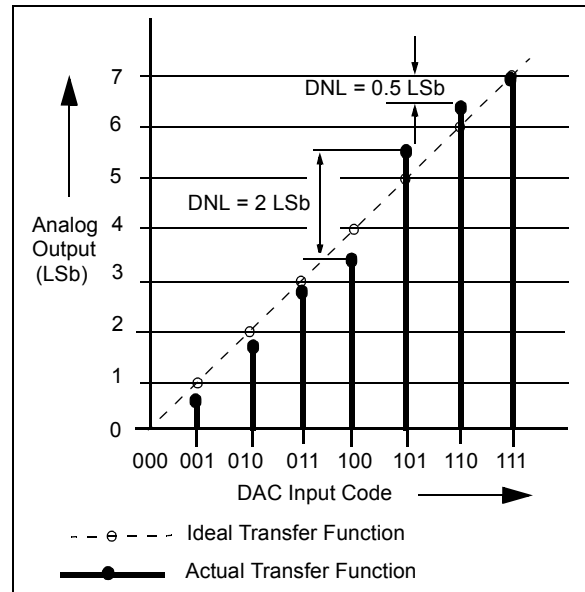


FIGURE B-5: DNL ACCURACY.

# MCP48FVBXX

## B.13 Settling Time

Settling time is the time delay required for the  $V_{OUT}$  voltage to settle into its new output value. This time is measured from the start of code transition to when the  $V_{OUT}$  voltage is within the specified accuracy.

In the MCP48FVBXX, the settling time is a measure of the time delay until the  $V_{OUT}$  voltage reaches within 0.5 LSB of its final value, when the volatile DAC Register changes from 1/4 to 3/4 of the full-scale range (12-bit device: 400h to C00h).

## B.14 Major-Code Transition Glitch

Major-Code transition glitch is the impulse energy injected into the DAC analog output when the code in the DAC register changes state. It is normally specified as the area of the glitch in nV-Sec, and is measured when the digital code is changed by 1 LSB at the major carry transition.

Example: 011...111 to 100...000  
or 100...000 to 011...111

## B.15 Digital Feedthrough

Digital feedthrough is the glitch that appears at the analog output, caused by coupling from the digital input pins of the device. The area of the glitch is expressed in nV-Sec, and is measured with a full-scale change on the digital input pins.

Example: all 0s to all 1s and vice versa.

The digital feedthrough is measured when the DAC is not being written to the output register.

## B.16 -3 dB Bandwidth

This is the frequency of the signal at the  $V_{REF}$  pin that causes the voltage at the  $V_{OUT}$  pin to fall -3 dB value from a static value on the  $V_{REF}$  pin. The output decreases due to the RC characteristics of the resistor ladder and the characteristics of the output buffer.

## B.17 Power-Supply Sensitivity (PSS)

PSS indicates how the output of the DAC is affected by changes in the supply voltage. PSS is the ratio of the change in  $V_{OUT}$  to a change in  $V_{DD}$  for mid-scale output of the DAC. The  $V_{OUT}$  is measured while the  $V_{DD}$  is varied from 5.5V to 2.7V as a step ( $V_{REF}$  voltage held constant), and expressed in %/%, which is the % change of the DAC output voltage with respect to the % change of the  $V_{DD}$  voltage.

### EQUATION B-8: PSS CALCULATION

$$PSS = \frac{V_{OUT(@5.5V)} - V_{OUT(@2.7V)}}{\frac{V_{OUT(@5.5V)}}{(5.5V - 2.7V) / 5.5V}}$$

Where:

PSS is expressed in %/ %.

$V_{OUT(@5.5V)}$  = The measured DAC output voltage with  $V_{DD} = 5.5V$ .

$V_{OUT(@2.7V)}$  = The measured DAC output voltage with  $V_{DD} = 2.7V$ .

## B.18 Power-Supply Rejection Ratio (PSRR)

PSRR indicates how the output of the DAC is affected by changes in the supply voltage. PSRR is the ratio of the change in  $V_{OUT}$  to a change in  $V_{DD}$  for full-scale output of the DAC. The  $V_{OUT}$  is measured while the  $V_{DD}$  is varied  $\pm 10\%$  ( $V_{REF}$  voltage held constant), and expressed in dB or  $\mu V/V$ .

## B.19 $V_{OUT}$ Temperature Coefficient

The  $V_{OUT}$  Temperature Coefficient quantifies the error in the resistor ladder's resistance ratio (DAC Register code value) and Output Buffer due to temperature drift.

## B.20 Absolute Temperature Coefficient

The absolute temperature coefficient quantifies the error in the end-to-end output voltage (Nominal output voltage  $V_{OUT}$ ) due to temperature drift. For a DAC this error is typically not an issue due to the ratiometric aspect of the output.

## B.21 Noise Spectral Density

Noise spectral density is a measurement of the device's internally-generated random noise, and is characterized as a spectral density (voltage per  $\sqrt{\text{Hz}}$ ). It is measured by loading the DAC to the mid-scale value and measuring the noise at the  $V_{OUT}$  pin. It is measured in  $nV/\sqrt{\text{Hz}}$ .

## PRODUCT IDENTIFICATION SYSTEM

To order or obtain information, e.g., on pricing or delivery, refer to the factory or the listed sales office.

<u>PART NO.</u>	<u>X</u> <sup>(1)</sup>	<u>X</u>	<u>— /XX</u>
Device	Tape and Reel	Temperature Range	Package
<p><b>Device:</b></p> <p>MCP48FVB01: Single-Channel 8-Bit Volatile DAC with External + Internal References</p> <p>MCP48FVB02: Dual-Channel 8-Bit Volatile DAC with External + Internal References</p> <p>MCP48FVB11: Single-Channel 10-Bit Volatile DAC with External + Internal References</p> <p>MCP48FVB12: Dual-Channel 10-Bit Volatile DAC with External + Internal References</p> <p>MCP48FVB21: Single-Channel 12-Bit Volatile DAC with External + Internal References</p> <p>MCP48FVB22: Dual-Channel 12-Bit Volatile DAC with External + Internal References</p> <p><b>Tape and Reel:</b> T = Tape and Reel <sup>(1)</sup> Blank = Tube</p> <p><b>Temperature Range:</b> E = -40°C to +125°C (Extended)</p> <p><b>Package:</b> UN = Plastic Micro Small Outline (MSOP), 10-Lead</p>			
<p><b>Examples:</b></p> <p>a) MCP48FVB01-E/UN: 8-bit V<sub>OUT</sub> resolution, Single channel, Tube, Extended temperature, 10-lead MSOP package</p> <p>b) MCP48FVB01T-E/UN: 8-bit V<sub>OUT</sub> resolution, Single channel, Tape and Reel, Extended temperature, 10-lead MSOP Package</p> <p>a) MCP48FVB11-E/UN: 10-bit V<sub>OUT</sub> resolution, Single channel, Tube, Extended temperature, 10-lead MSOP package</p> <p>b) MCP48FVB11T-E/UN: 10-bit V<sub>OUT</sub> resolution, Single channel, Tape and Reel, Extended temperature, 10-lead MSOP package</p> <p>a) MCP48FVB21-E/UN: 12-bit V<sub>OUT</sub> resolution, Single channel, Tube, Extended temperature, 10-lead MSOP package</p> <p>b) MCP48FVB21T-E/UN: 12-bit V<sub>OUT</sub> resolution, Single channel, Tape and Reel, Extended temperature, 10-lead MSOP package</p> <p>a) MCP48FVB22-E/UN: 12-bit V<sub>OUT</sub> resolution, Dual channel, Tube, Extended temperature, 10-lead MSOP package</p> <p>b) MCP48FVB22T-E/UN: 12-bit V<sub>OUT</sub> resolution, Dual channel, Tape and Reel, Extended temperature, 10-lead MSOP package</p> <p><b>Note 1:</b> Tape and Reel identifier only appears in the catalog part number description. This identifier is used for ordering purposes and is not printed on the device package. Check with your Microchip sales office for package availability for the Tape and Reel option.</p>			

# MCP48FVBXX

---

NOTES:

---

**Note the following details of the code protection feature on Microchip devices:**

- Microchip products meet the specification contained in their particular Microchip Data Sheet.
- Microchip believes that its family of products is one of the most secure families of its kind on the market today, when used in the intended manner and under normal conditions.
- There are dishonest and possibly illegal methods used to breach the code protection feature. All of these methods, to our knowledge, require using the Microchip products in a manner outside the operating specifications contained in Microchip's Data Sheets. Most likely, the person doing so is engaged in theft of intellectual property.
- Microchip is willing to work with the customer who is concerned about the integrity of their code.
- Neither Microchip nor any other semiconductor manufacturer can guarantee the security of their code. Code protection does not mean that we are guaranteeing the product as "unbreakable."

Code protection is constantly evolving. We at Microchip are committed to continuously improving the code protection features of our products. Attempts to break Microchip's code protection feature may be a violation of the Digital Millennium Copyright Act. If such acts allow unauthorized access to your software or other copyrighted work, you may have a right to sue for relief under that Act.

---

Information contained in this publication regarding device applications and the like is provided only for your convenience and may be superseded by updates. It is your responsibility to ensure that your application meets with your specifications. MICROCHIP MAKES NO REPRESENTATIONS OR WARRANTIES OF ANY KIND WHETHER EXPRESS OR IMPLIED, WRITTEN OR ORAL, STATUTORY OR OTHERWISE, RELATED TO THE INFORMATION, INCLUDING BUT NOT LIMITED TO ITS CONDITION, QUALITY, PERFORMANCE, MERCHANTABILITY OR FITNESS FOR PURPOSE. Microchip disclaims all liability arising from this information and its use. Use of Microchip devices in life support and/or safety applications is entirely at the buyer's risk, and the buyer agrees to defend, indemnify and hold harmless Microchip from any and all damages, claims, suits, or expenses resulting from such use. No licenses are conveyed, implicitly or otherwise, under any Microchip intellectual property rights unless otherwise stated.

#### **Trademarks**

The Microchip name and logo, the Microchip logo, dsPIC, FlashFlex, flexPWR, JukeBlox, KEELOQ, KEELOQ logo, Klear, LANCheck, MediaLB, MOST, MOST logo, MPLAB, OptoLyzer, PIC, PICSTART, PIC<sup>32</sup> logo, RightTouch, SpyNIC, SST, SST Logo, SuperFlash and UNI/O are registered trademarks of Microchip Technology Incorporated in the U.S.A. and other countries.

The Embedded Control Solutions Company and mTouch are registered trademarks of Microchip Technology Incorporated in the U.S.A.

Analog-for-the-Digital Age, BodyCom, chipKIT, chipKIT logo, CodeGuard, dsPICDEM, dsPICDEM.net, ECAN, In-Circuit Serial Programming, ICSP, Inter-Chip Connectivity, KlearNet, KlearNet logo, MiWi, motorBench, MPASM, MPF, MPLAB Certified logo, MPLIB, MPLINK, MultiTRAK, NetDetach, Omniscient Code Generation, PICDEM, PICDEM.net, PICKit, PICTail, RightTouch logo, REAL ICE, SQI, Serial Quad I/O, Total Endurance, TSHARC, USBCheck, VariSense, ViewSpan, WiperLock, Wireless DNA, and ZENA are trademarks of Microchip Technology Incorporated in the U.S.A. and other countries.

SQTP is a service mark of Microchip Technology Incorporated in the U.S.A.

Silicon Storage Technology is a registered trademark of Microchip Technology Inc. in other countries.

GestIC is a registered trademark of Microchip Technology Germany II GmbH & Co. KG, a subsidiary of Microchip Technology Inc., in other countries.

All other trademarks mentioned herein are property of their respective companies.

© 2015, Microchip Technology Incorporated, Printed in the U.S.A., All Rights Reserved.

ISBN: 978-1-5224-0047-9

*Microchip received ISO/TS-16949:2009 certification for its worldwide headquarters, design and wafer fabrication facilities in Chandler and Tempe, Arizona; Gresham, Oregon and design centers in California and India. The Company's quality system processes and procedures are for its PIC<sup>®</sup> MCUs and dsPIC<sup>®</sup> DSCs, KEELOQ<sup>®</sup> code hopping devices, Serial EEPROMs, microperipherals, nonvolatile memory and analog products. In addition, Microchip's quality system for the design and manufacture of development systems is ISO 9001:2000 certified.*

---

**QUALITY MANAGEMENT SYSTEM**  
**CERTIFIED BY DNV**  
**== ISO/TS 16949 ==**



# MICROCHIP

## Worldwide Sales and Service

### AMERICAS

**Corporate Office**  
2355 West Chandler Blvd.  
Chandler, AZ 85224-6199  
Tel: 480-792-7200  
Fax: 480-792-7277  
Technical Support:  
<http://www.microchip.com/support>  
Web Address:  
[www.microchip.com](http://www.microchip.com)

**Atlanta**  
Duluth, GA  
Tel: 678-957-9614  
Fax: 678-957-1455

**Austin, TX**  
Tel: 512-257-3370

**Boston**  
Westborough, MA  
Tel: 774-760-0087  
Fax: 774-760-0088

**Chicago**  
Itasca, IL  
Tel: 630-285-0071  
Fax: 630-285-0075

**Cleveland**  
Independence, OH  
Tel: 216-447-0464  
Fax: 216-447-0643

**Dallas**  
Addison, TX  
Tel: 972-818-7423  
Fax: 972-818-2924

**Detroit**  
Novi, MI  
Tel: 248-848-4000

**Houston, TX**  
Tel: 281-894-5983

**Indianapolis**  
Noblesville, IN  
Tel: 317-773-8323  
Fax: 317-773-5453

**Los Angeles**  
Mission Viejo, CA  
Tel: 949-462-9523  
Fax: 949-462-9608

**New York, NY**  
Tel: 631-435-6000

**San Jose, CA**  
Tel: 408-735-9110

**Canada - Toronto**  
Tel: 905-673-0699  
Fax: 905-673-6509

### ASIA/PACIFIC

**Asia Pacific Office**  
Suites 3707-14, 37th Floor  
Tower 6, The Gateway  
Harbour City, Kowloon

**Hong Kong**  
Tel: 852-2943-5100  
Fax: 852-2401-3431

**Australia - Sydney**  
Tel: 61-2-9868-6733  
Fax: 61-2-9868-6755

**China - Beijing**  
Tel: 86-10-8569-7000  
Fax: 86-10-8528-2104

**China - Chengdu**  
Tel: 86-28-8665-5511  
Fax: 86-28-8665-7889

**China - Chongqing**  
Tel: 86-23-8980-9588  
Fax: 86-23-8980-9500

**China - Dongguan**  
Tel: 86-769-8702-9880

**China - Hangzhou**  
Tel: 86-571-8792-8115  
Fax: 86-571-8792-8116

**China - Hong Kong SAR**  
Tel: 852-2943-5100  
Fax: 852-2401-3431

**China - Nanjing**  
Tel: 86-25-8473-2460  
Fax: 86-25-8473-2470

**China - Qingdao**  
Tel: 86-532-8502-7355  
Fax: 86-532-8502-7205

**China - Shanghai**  
Tel: 86-21-5407-5533  
Fax: 86-21-5407-5066

**China - Shenyang**  
Tel: 86-24-2334-2829  
Fax: 86-24-2334-2393

**China - Shenzhen**  
Tel: 86-755-8864-2200  
Fax: 86-755-8203-1760

**China - Wuhan**  
Tel: 86-27-5980-5300  
Fax: 86-27-5980-5118

**China - Xian**  
Tel: 86-29-8833-7252  
Fax: 86-29-8833-7256

### ASIA/PACIFIC

**China - Xiamen**  
Tel: 86-592-2388138  
Fax: 86-592-2388130

**China - Zhuhai**  
Tel: 86-756-3210040  
Fax: 86-756-3210049

**India - Bangalore**  
Tel: 91-80-3090-4444  
Fax: 91-80-3090-4123

**India - New Delhi**  
Tel: 91-11-4160-8631  
Fax: 91-11-4160-8632

**India - Pune**  
Tel: 91-20-3019-1500

**Japan - Osaka**  
Tel: 81-6-6152-7160  
Fax: 81-6-6152-9310

**Japan - Tokyo**  
Tel: 81-3-6880-3770  
Fax: 81-3-6880-3771

**Korea - Daegu**  
Tel: 82-53-744-4301  
Fax: 82-53-744-4302

**Korea - Seoul**  
Tel: 82-2-554-7200  
Fax: 82-2-558-5932 or  
82-2-558-5934

**Malaysia - Kuala Lumpur**  
Tel: 60-3-6201-9857  
Fax: 60-3-6201-9859

**Malaysia - Penang**  
Tel: 60-4-227-8870  
Fax: 60-4-227-4068

**Philippines - Manila**  
Tel: 63-2-634-9065  
Fax: 63-2-634-9069

**Singapore**  
Tel: 65-6334-8870  
Fax: 65-6334-8850

**Taiwan - Hsin Chu**  
Tel: 886-3-5778-366  
Fax: 886-3-5770-955

**Taiwan - Kaohsiung**  
Tel: 886-7-213-7828

**Taiwan - Taipei**  
Tel: 886-2-2508-8600  
Fax: 886-2-2508-0102

**Thailand - Bangkok**  
Tel: 66-2-694-1351  
Fax: 66-2-694-1350

### EUROPE

**Austria - Wels**  
Tel: 43-7242-2244-39  
Fax: 43-7242-2244-393

**Denmark - Copenhagen**  
Tel: 45-4450-2828  
Fax: 45-4485-2829

**France - Paris**  
Tel: 33-1-69-53-63-20  
Fax: 33-1-69-30-90-79

**Germany - Dusseldorf**  
Tel: 49-2129-3766400

**Germany - Karlsruhe**  
Tel: 49-721-625370

**Germany - Munich**  
Tel: 49-89-627-144-0  
Fax: 49-89-627-144-44

**Italy - Milan**  
Tel: 39-0331-742611  
Fax: 39-0331-466781

**Italy - Venice**  
Tel: 39-049-7625286

**Netherlands - Drunen**  
Tel: 31-416-690399  
Fax: 31-416-690340

**Poland - Warsaw**  
Tel: 48-22-3325737

**Spain - Madrid**  
Tel: 34-91-708-08-90  
Fax: 34-91-708-08-91

**Sweden - Stockholm**  
Tel: 46-8-5090-4654

**UK - Wokingham**  
Tel: 44-118-921-5800  
Fax: 44-118-921-5820

07/14/15