



2X36 W digital dimmable ballast with L6574 and ST7FDALI

Introduction

This document describes a high-efficiency, high power factor, low THD and digital dimming electronic ballast designed to drive 2X36 W T8 tube lamps.

The system consists of three main blocks:

The high-frequency ballast includes an active power factor correction circuit based on the L6562 for universal input voltage as well as a ballast control circuit based on the L6574. The digital dimming is performed by interfacing the ST7FDALI microcontroller with the analog half-bridge driver.

The DALI control unit is dedicated to address the slaves, to display the lamp status and to send the dimming commands. This unit is provided with a keyboard which allows setting different dimming scenes over a wide range (5-100%) as well as putting in standby and restarting the ballast. The DALI communication protocol includes single and group mode, as well as broadcast mode to address the slaves.

The AC-DC adapter is based on the VIPer12A-E. This is an offline double-output isolated power supply in DCM flyback configuration. The outputs are set for 20 V to supply the communication bus and for 5 V to supply the MASTER microcontroller.

The three blocks are described in detail and their performances are shown. In addition some of DALI basics are explained.

Contents

- 1 Block diagram and system operating conditions 5**
- 2 High-frequency ballast 7**
 - 2.1 PFC converter 11
 - 2.2 Half-bridge inverter and ballast 14
 - 2.2.1 Lamp dimming 16
 - 2.2.2 Supply section 17
 - 2.2.3 Lamp turn-on and lamp turn-off 18
 - 2.2.4 Verification of lamp status 21
 - 2.2.5 Ballast performances 22
- 3 DALI master unit 24**
 - 3.1 Master unit schematic and bill of material 26
- 4 Basics of DALI 29**
- 5 DALI master AC-DC adapter 32**
 - 5.1 Adapter description 32
 - 5.2 Adapter bill of material 35
 - 5.3 Adapter performances 36
 - 5.3.1 Steady state tests 36
 - 5.3.2 Startup behavior 37
 - 5.3.3 Dynamic load tests 38
 - 5.3.4 Line regulation 39
 - 5.3.5 Load regulation 39
 - 5.3.6 Efficiency variation 40
 - 5.3.7 Conducted emissions test 40
- 6 References 41**
- 7 Revision history 41**

List of tables

Table 1.	System operating conditions	6
Table 2.	Ballast-slave communication	8
Table 3.	Ballast bill of material	8
Table 4.	PFC operating conditions	12
Table 5.	Power stage design equations	12
Table 6.	L6562 biasing circuitry design equations	13
Table 7.	Lamp parameters	14
Table 8.	L6574 biasing circuitry design equations for operating conditions	16
Table 9.	Ballast performances	23
Table 10.	Master unit bill of material	27
Table 11.	SMPS operating conditions	32
Table 12.	Adapter bill of material	35
Table 13.	Document revision history	41

List of figures

Figure 1.	System block diagram	5
Figure 2.	2X36 W digital dimmable ballast with L6574 and ST7FDALI	6
Figure 3.	Ballast schematic	7
Figure 4.	PFC performances at 230 V _{ac} -50 Hz	13
Figure 5.	Lamp ballast model.	14
Figure 6.	Ballast transfer functions (magnitude)	15
Figure 7.	DALI protocol brightness values	17
Figure 8.	Ballast controls timing chart	19
Figure 9.	Idle state	20
Figure 10.	Turn-on procedure	20
Figure 11.	Turn-off procedure	20
Figure 12.	Forward frame timing	21
Figure 13.	Backward frame timing	22
Figure 14.	Ballast startup at 230 V _{ac} -full power	22
Figure 15.	Lamps turn-on at 230 V _{ac} -full power.	22
Figure 16.	Lamps running at 230 V _{ac} - full power	23
Figure 17.	Polling keyboard	24
Figure 18.	Pressed button event	25
Figure 19.	Master unit schematic.	26
Figure 20.	Cable wiring	29
Figure 21.	Master flowchart	30
Figure 22.	Slave flowchart	31
Figure 23.	Adapter schematic	33
Figure 24.	Adapter PCB layout - top side -silkscreen (to scale).	34
Figure 25.	Adapter PCB layout - bottom side - copper tracks (to scale)	34
Figure 26.	Flyback transformer	34
Figure 27.	VIPer12A-E steady state behavior at full load at 110 V _{ac} - 60 Hz	36
Figure 28.	VIPer12A-E steady state behavior at full load at 230 V _{ac} - 50 Hz	36
Figure 29.	VIPer12A-E steady state behavior at minimum load at 110 V _{ac} - 60 Hz	36
Figure 30.	VIPer12A-E steady state behavior at minimum load at 230 V _{ac} - 50 Hz	36
Figure 31.	Startup waveforms at full load at 110 V _{ac} - 60 Hz	37
Figure 32.	Startup waveforms at full load at 230 V _{ac} - 50 Hz	37
Figure 33.	Startup waveforms at minimum load at 110 V _{ac} - 60 Hz	38
Figure 34.	Startup waveforms at minimum load at 230 V _{ac} - 50 Hz	38
Figure 35.	Dynamic load waveforms at 110 V _{ac} - 60 Hz	38
Figure 36.	Dynamic load waveforms at 230 V _{ac} - 50 Hz	38
Figure 37.	Line regulation	39
Figure 38.	Load regulation	39
Figure 39.	Efficiency variations vs. input voltage at full load	40
Figure 40.	Conducted emissions at 110 V _{ac} 60 Hz - full load - line 1 peak detector	40
Figure 41.	Conducted emissions at 110 V _{ac} 60 Hz - full load - line 2 peak detector	40
Figure 42.	Conducted emissions at 230 V _{ac} 50 Hz - full load - line 1 peak detector	41
Figure 43.	Conducted emissions at 230 V _{ac} 50 Hz - full load - line 2 peak detector	41

1 Block diagram and system operating conditions

Figure 1 shows the block diagram of the system.

Figure 1. System block diagram

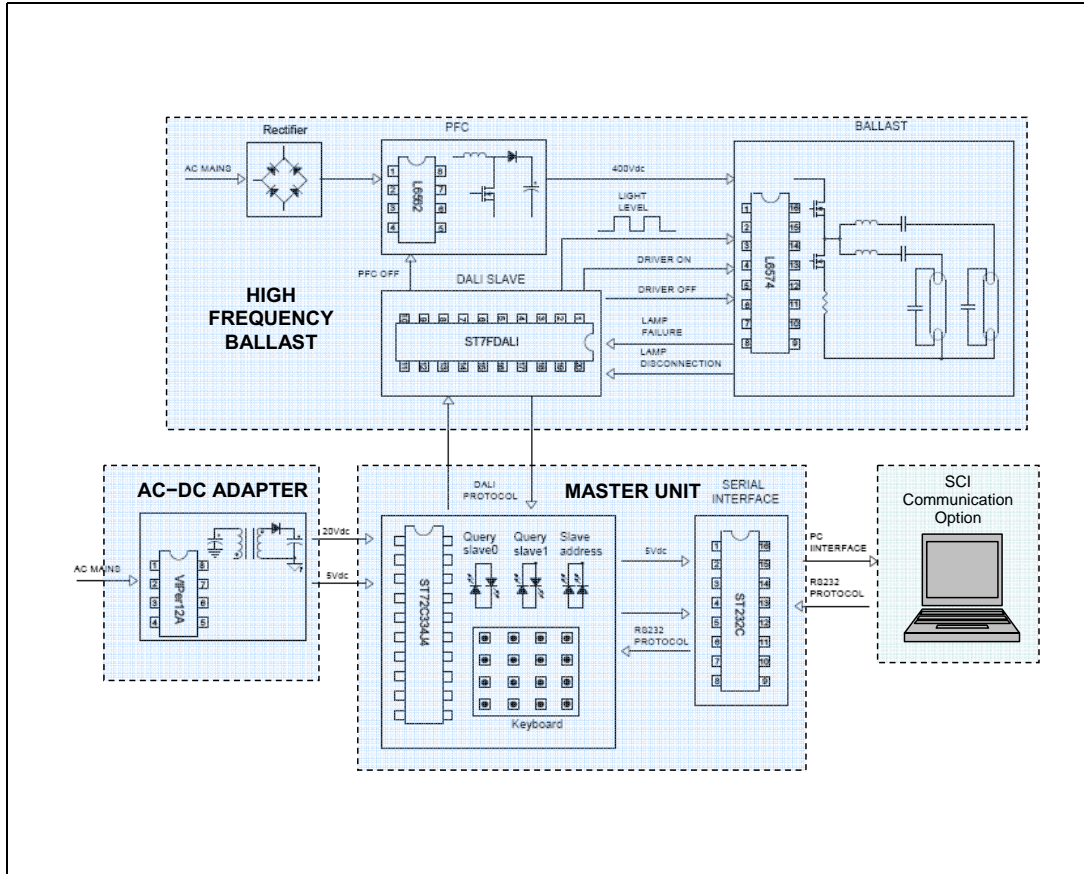

SCI communication is considered as an option.

The present system has been designed according to the following specifications:

Table 1. System operating conditions

Parameter	Value
Input voltage range	176-265 Vac/50 Hz; 90-140 Vac/60 Hz
Lamp type	2X36 W T8 tube lamps
Circuit power (max)	80 W
Lamp power (max)	72 W
Dimming range	5% to 100%
Power factor	> 0.99
Current THD	< 10%
Warm start	< 1.5 sec
Standby mode power	< 0.6 W

In addition to the previous specs, the DALI communications are optically isolated, the digital dimming is performed with high precision, and the lamp filament preheating time is programmable as well as the ignition time.

Figure 2. 2X36 W digital dimmable ballast with L6574 and ST7FDALI

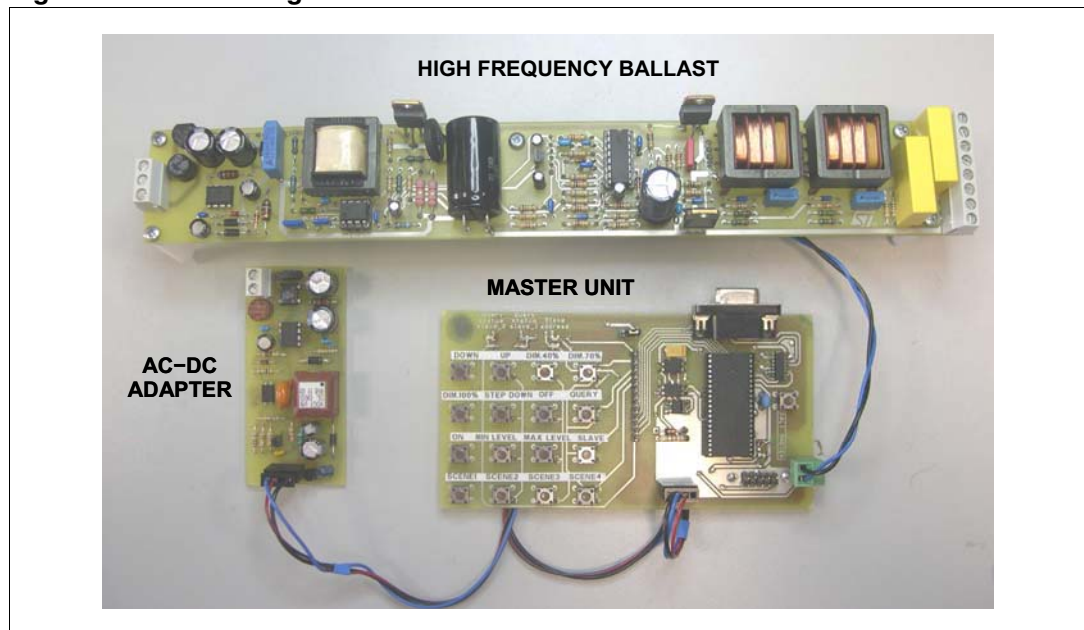

2 High-frequency ballast

This section describes the high-frequency ballast board which includes the power factor correction stage, the half-bridge inverter driving circuitry, the output stage and the DALI slave unit. The schematic of the board is shown in [Figure 3](#).

Figure 3. Ballast schematic

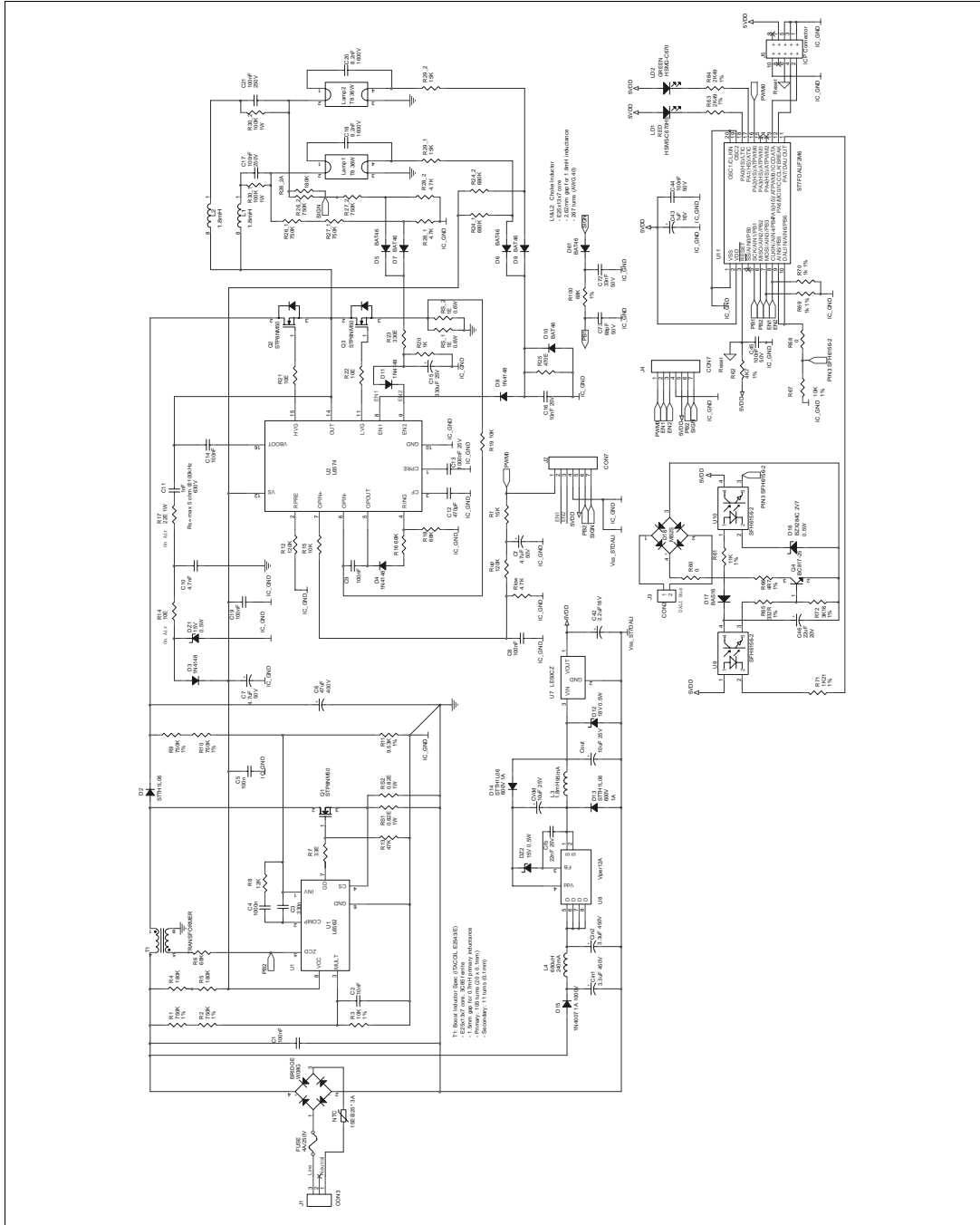

This block is essentially a "double board" as the DALI slave board and its external circuitry are mounted on a small separated board which is connected to the bottom side by means of a 7-pin connector. [Table 2](#) shows the ballast-slave communication.

Table 2. Ballast-slave communication

Pin ref.	Description	Analog stage \longleftrightarrow Microcontroller
1	PWM0 (ref op-amp)	\longleftarrow
2	Disable L6574 EN1 & disconnected lamp	\longleftrightarrow
3	Enable L6574 EN2 & not ignited lamp	\longleftrightarrow
4	GND	\longleftrightarrow
5	5 VDD	\longrightarrow
6	PB2 disable PFC	\longleftarrow
7	SIGN (lamp failure)	\longrightarrow

Table 3. Ballast bill of material

Reference	Value	Description
Bridge	W08G 1.5 A 800 V	Bridge rectifier
Cout, CVdd	10 μ F 25 V	Electrolytic cap
C7,Cf	4.7 μ F 50 V	Electrolytic cap
Cfb	22 nF 25 V	Ceramic cap
Cin1,Cin2	3.3 μ F 450 V	Electrolytic cap
C1	100 nF 400 V	Polyester cap
C2	10 nF 50 V	Ceramic cap
C3	330 nF 50 V	Ceramic cap
C4	1000 nF 50 V	Ceramic cap
C5,C8,C9,C19	100 nF 50 V	Ceramic cap
C6	47 μ F 450 V	Electrolytic cap
C14	100 nF 100 V	Ceramic cap
C10	4.7 nF 100 V	Ceramic cap
C11	1 nF 630 V	Evov Rifa polypropylene cap $R_{s_{max}} = 5 \Omega$ at 100 kHz
C12	470 pF 50 V	Ceramic cap
C13	1 μ F 50 V	Ceramic cap
C15	330 μ F 25 V	Electrolytic cap
C16	10 nF 25 V	Ceramic cap
C17, C21	100 nF 250 V	Polyester cap
C18,C20	8.2 nF 1600 V	Polyester cap
C42	2.2 μ F 16 V	Electrolytic cap

Table 3. Ballast bill of material (continued)

Reference	Value	Description
C43	1 μ F 20 V	SMD tantalum cap
C44,C45	100 nF 50 V	0805 SMD cap
C46	22 μ F 20 V	SMD tantalum cap
C72	33 nF 50 V	0805 SMD cap
C73	68 pF 50 V	0805 SMD cap
DZ1,DZ2	15 V 0.5 W	Zener diode
D2,D13,D14	STTH1L06	STMicroelectronics ultrafast high voltage rectifier 1 A 600 V
D3,D4,D8,D11	1N4148	Small signal rectifier 200 mA 100 V
D5,D6,D7,D9,D10,D61	BAT46 DO 35	STMicroelectronics small signal Schottky diode
D12	18 V 0.5 W	Zener diode
D15	1N4007 1 A 1000 V	General purpose rectifier
D16	MB2S 0.5 A 200 V	SMD bridge rectifier
D17	BAS16	Small signal diode
D18	BZX284C 2V7	0.5 W Zener diode
FUSE	4 A 250 V	Radial fuse
J1	Input 250 V connector	3-way PCB screw terminal, 5.08 mm
J2	Ballast-slave connector	7-way strip line socket
J3	Dali Bus	2-way vertical PCB header, 3.81 mm pitch
J4	Ballast-slave connector	7-way strip line connector
J5	ICP connector	10-way 2-row vertical through-hole boxed header
J13		4-way strip line socket
J14		4-way strip line connector
Lamp 1	Lamp connector	4-way PCB screw terminal, 5.08 mm
Lamp 2	Lamp connector	4-way PCB screw terminal, 5.08 mm
LD1	LS M67K-H2L1-1	2 mA red LED SMD 0805
LD2	LG M67K-G1J2-24	2 mA green LED SMD 0805
L1,L2	1.8 mH	Choke inductor 2.62 mm gap, 267 turns (AWG40); E25x13x7
L3	1.8 mH 95 mA	Epcos BC series Axial inductor
L4	680 μ H 240 mA	Epcos LBC series Axial inductor
NTC	15 Ω at 25 $^{\circ}$ C 3 A	Inrush current suppressor
Q1,Q2,Q3	STP8NM50 TO220	STMicroelectronics N-CHANNEL 550 V 0.7 Ω - 8 A MDmesh MOSFET

Table 3. Ballast bill of material (continued)

Reference	Value	Description
Q4	BC817-25	NPN small signal bipolar
RS_1,RS_2	1 Ω	0.6 W 1% metal film resistor
RS1,RS2	0.82 Ω	1 W resistor
R29_1, R29_2,Rf	15 k Ω	Resistor
R28_1, R28_2,Rlow	4.7 k Ω	Resistor
R12,Rup	120 k Ω	Resistor
R1,R2,R9, R10, R26_1, R26_2, R27_1, R27_2	750 k Ω	0.6 W 1% resistor
R15,R19	10 k Ω	Resistor
R3	10 k Ω	0.6 W 1% resistor
R4,R5, R26_2A	180 k Ω	Resistor
R6,R16,R18	68 k Ω	Resistor
R7	33 Ω	Resistor
R8	12 k Ω	Resistor
R11	9.53 k Ω	1% Resistor
R13	47 k Ω	Resistor
R14,R21,R22	10 Ω	Resistor
R17	22 Ω	1 W resistor
R20	1 k Ω	Resistor
R23	330 Ω	Resistor
R25	470 Ω	Resistor
R60,R68	0 Ω	SMD resistor 0805
R61	11 k Ω	1% SMD resistor 0805
R62	4.7 k Ω	1% SMD resistor 0805
R63,R64	1 k Ω	1% SMD resistor 0805
R65	330 Ω	1% SMD resistor 0805
R66	4.7 Ω	1% SMD resistor 0805
R67	10 k Ω	1% SMD resistor 0805
R69,R70	1 k Ω	1% SMD resistor 0805
R71	1.2 k Ω	1% SMD resistor 0805
R72	3 k Ω	1% SMD resistor 0805

Table 3. Ballast bill of material (continued)

Reference	Value	Description
R100	68 k Ω	1% SMD resistor 0805
R24_1,R24_2	680 k Ω	Resistor
R30_1,R30_2	100 k Ω	2 W resistor
T1	Transformer	Choke boost inductor (ITACOIL E2543/E)
U1	L6562N	STMicroelectronics transition-mode PFC controller
U2	L6574	STMicroelectronics ballast driver
U7	LE50CZ TO-92	STMicroelectronics very low drop voltage regulators
U8	VIPer12A-E DIP8	STMicroelectronics offline SMPS primary IC 730 V 0.4 A 27R
U9,U10	SFH6156-2	Optocoupler
U11	ST7FDALIF2M6 SO20	STMicroelectronics 8-bit MCU with single voltage Flash memory, data EEPROM, ADC, timers, SPI, DALI

Note: Resistors are 0.25 W unless specified. Q1, Q2 & Q3 are mounted with 8 °C/W heatsink.

2.1 PFC converter

This block allows drawing a quasi-sinusoidal current from the mains, in phase with the line voltage in order to get a PF very close to 1 (more than 0.99).

To achieve such high PF the boost topology is implemented because of the advantages it offers:

- Minimum number of external components, thus making it a low-cost solution
- Low input di/dt thus minimizing the noise generated at the input and, therefore, the requirements on the input EMI filter
- The switch is source-grounded, therefore is easy to drive

However, boost topology requires the DC output voltage (400 Vdc) to be higher than the maximum expected line peak voltage.

ST's L6562 has been used as the driver. It implements a transition mode control (fixed ON time, variable frequency), that, for such output power, is preferred to the fixed frequency average current mode being simpler and cheaper. The circuit operates on the boundary between continuous and discontinuous current mode.

Besides providing good results in terms of power factor, this IC considerably reduces the Total Harmonic Distortion (THD) as it reduces the conduction dead-angle that occurs to the AC input current near the zero-crossings of the line voltage.

The basic design specifications are listed in [Table 4](#).

Table 4. PFC operating conditions

Parameter	Value
Mains voltage range: $V_{rms}(\min) - V_{rms}(\max)$	90 – 265 Vac
Regulated DC output voltage: V_o	400 Vdc
Rated output power: P_o	75 W
Minimum switching frequency: f_{sw}	35 kHz
Maximum output voltage ripple: ΔV_o	$< \pm 10$ V
Maximum overvoltage admitted: ΔV_{OVP}	60 V
Expected efficiency: η_{PFC}	> 90 V

For reference, it is useful to define also the following quantities:

- Input power: $P_i (= P_o / \eta) \approx 80$ W
- Maximum mains RMS current: $i_{rms} (= P_i / V_{rms}(\min)) \approx 1$ A
- Rated output current: $I_o (= P_o / V_o) \approx 0.2$ A

The design guidelines are deeply explained in AN966 ("L6561, enhanced transition mode power factor corrector"), AN1757 ("Switching from the L6561 to the L6562) and AN1089 ("control loop model of L6561-based TM PFC"). The main design formulas are summarized as follows in [Table 5](#).

Table 5. Power stage design equations

Input capacitor (C1)	Boost inductor	Power MOSFET (Q1)	Boost diode (D1)
$C1 = \frac{I_{rms}}{2\pi \cdot f_{sw} \cdot r \cdot V_{inrmsmin}}$ <p>where</p> $r = 0.01 + 0.1$	$Volume \geq 4K \cdot L \cdot I_{rms}^2$ $L = \frac{V_{rms}^2 \cdot (V_o - \sqrt{2} \cdot V_{rms})}{2 \cdot f_{sw} \cdot P_i \cdot V_o}$ <p>where</p> $K \approx 14 \cdot 10^{-3} \cdot \frac{I_e}{I_{gap}}$ $P_{cu} = \frac{4}{3} \cdot I_{rms}^2 \cdot R_{cu}$	$V_{DSS} = V_o + \Delta V_{OVP} + V_{margin}$ $P_{on} = I_{Qrms}^2 \cdot R_{DS(on)}$ <p>where</p> $I_{Qrms} = 2\sqrt{2} \cdot I_{rms} \cdot \sqrt{\frac{1}{6} - \frac{4\sqrt{2}}{9\pi} \cdot \frac{V_{rms}}{V_o}}$ $P_{cross} = V_o \cdot I_{rms} \cdot t_{fall} \cdot f_{sw}$ $P_{cap} = \left(3.3C_{oss} \cdot V_{drain}^{1.5} + \frac{1}{2} C_d \cdot V_{drain}^2 \right) \cdot f_{sw}$	$V_{RRM} = 1.2 \cdot V_o$ $I_F = 3 \cdot I_o$ $P_{losses} = V_T \cdot I_{DC} + R_d \cdot I_{rms}^2$
Output capacitor (C6)			
$C6 \geq \frac{P_o}{4\pi \cdot f \cdot V_o \cdot \Delta V_o}$			

Table 6. L6562 biasing circuitry design equations

Pin 1 (INV)	Pin 2 (COMP)	Pin 3 MULT	Pin 4 (CS)
$\Delta OVP = R_{high} \cdot 40 \cdot 10^{-6}$ $V_{out} = 2.5 \cdot \frac{(R_{high} + R_{low})}{R_{low}}$	<p>A RC-C network is placed between this pin and pin 1, leading to a low crossover frequency (some tens of hertz) as well as to an adequate phase margin.</p>	$R_{low} = \frac{V_{MULTpkx}}{250 \cdot 10^{-6}} = \frac{2.5}{250 \cdot 10^{-6}}$ $\frac{R_{low}}{R_{low} + R_{high}} = \frac{2.5}{\sqrt{2} \cdot V_{inrmsmax}}$ <p>A small capacitor of 10 nF filters the signal on MULT pin.</p>	$R_{sense} \leq \frac{1.65 \cdot \left(2.5 \cdot \frac{V_{inrmsmin}}{V_{inrmsmax}} \right)}{2 \cdot \sqrt{2} \cdot I_{inrms}}$ $P_d = R_s \cdot I_{Qrms}^2$
Pin 5 (ZCD)	Pin 6 (GND)	Pin 7 (GD)	Pin 8 Vcc
$m = \frac{(V_{out} - \sqrt{2} \cdot V_{inrmsmax})}{2.1 \cdot 1.15}$ $R6 \geq \frac{(V_{out} - \sqrt{2} \cdot V_{inrmsmin})}{m \cdot 3 \cdot 10^{-3}}$	<p>IC ground. As a layout hint, this pin has to be kept separated from power ground. All the IC signals have to be referred to this pin.</p>	<p>Gate driver. A "bleeder" resistor between the gate and the source is used to avoid undesired switch-on, without affecting the power consumption.</p>	<p>The supply voltage is provided by a capacitive power supply connected to the half-bridge inverter.</p> $R_{start} = \frac{V_{inrmsmin} \cdot \sqrt{2}}{I_{startup}}$

The PFC preregulator performances are shown in the following graphs:

Figure 4. PFC performances at 230 Vac-50 Hz

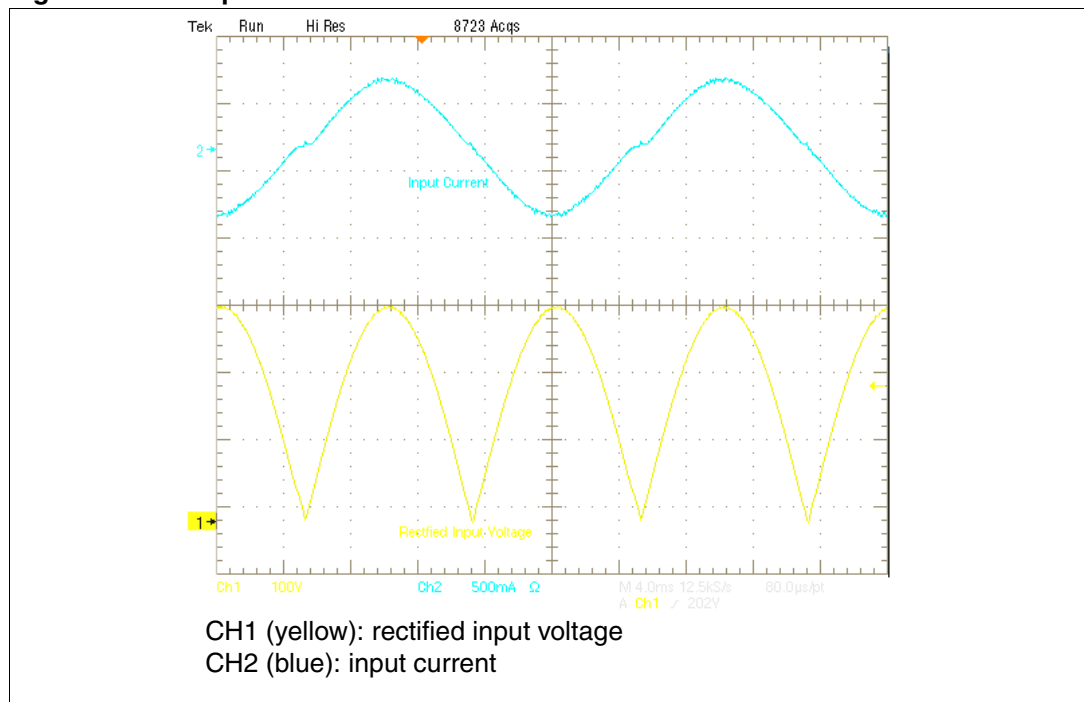

2.2 Half-bridge inverter and ballast

A voltage fed series resonant half-bridge inverter has been implemented to drive the tubes. This topology allows to easily operates in zero-voltage switching (ZVS) resonant mode, heavily reducing the transistor switching losses and the electromagnetic interference. In addition it guarantees design simplicity and low cost.

A parallel configuration has been chosen for the output stage. The half-bridge inverter operating conditions and the ballast design have been obtained by assuming, for each lamp, the following basic model:

Figure 5. Lamp ballast model

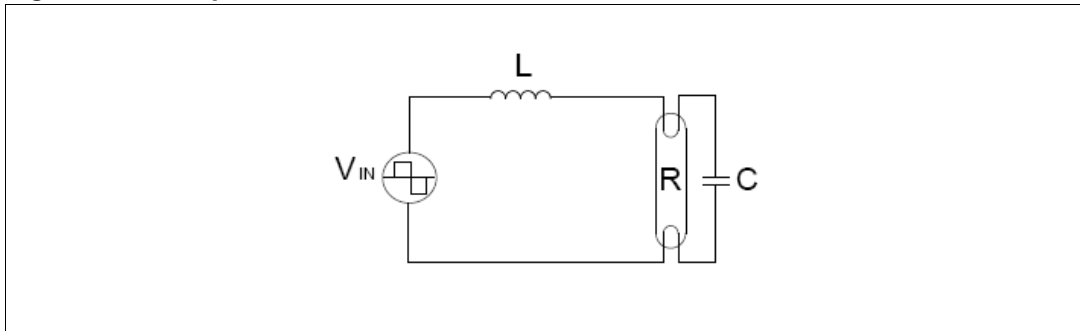

To increase the life time of the lamps a current mode preheat was preferred. The preheating current brings the cathodes to the correct temperature, then a high voltage ignites the lamp and finally the correct current guarantees the running power. These phases are ensured by changing the frequency of the input voltage and properly selecting V_{IN} , L and C . During preheating and ignition, the lamp is not conducting and the circuit is reduced to a series L-C. During running, the lamp is conducting and the circuit is an L in series with a parallel R-C. To determine the optimum values for L and C and to calculate the ballast operating frequencies the transfer functions for each mode of operation have to be inspected.

The table below shows the parameters and the values for a T8 36 W tube lamp which need to be known in order to calculate the ballast operating conditions.

Table 7. Lamp parameters

Parameter	Value
Input DC bus voltage: V_{dc}	400 V
Preheat current: I_{ph}	0.6 A
Preheat time: T_{ph}	1 sec
Max preheat voltage: V_{phmax}	300 Vpk
Ignition voltage: V_{ign}	800 Vpk
Running lamp power: P_{run}	34 W
Running lamp voltage: V_{run}	144 Vpk
Expected efficiency: η	95%

Once the lamp and its parameters have been chosen, the ballast design will be optimized by selecting the resonant components L and C as follows:

- Set T_{pre}
- Select f_{runmin} (> 20 kHz)
- Choose $\Delta f = f_{max} - f_{runmin}$
- Select L & C such that $f_{ph} > f_{run}$
- Select half-bridge switches
- Select L6574 biasing circuitry

The magnitude of the transfer function (lamp voltage divided by input voltage) for the two circuit configurations (preheating-ignition and running) illustrates the operating frequencies and where they lie with respect to one another.

Figure 6. Ballast transfer functions (magnitude)

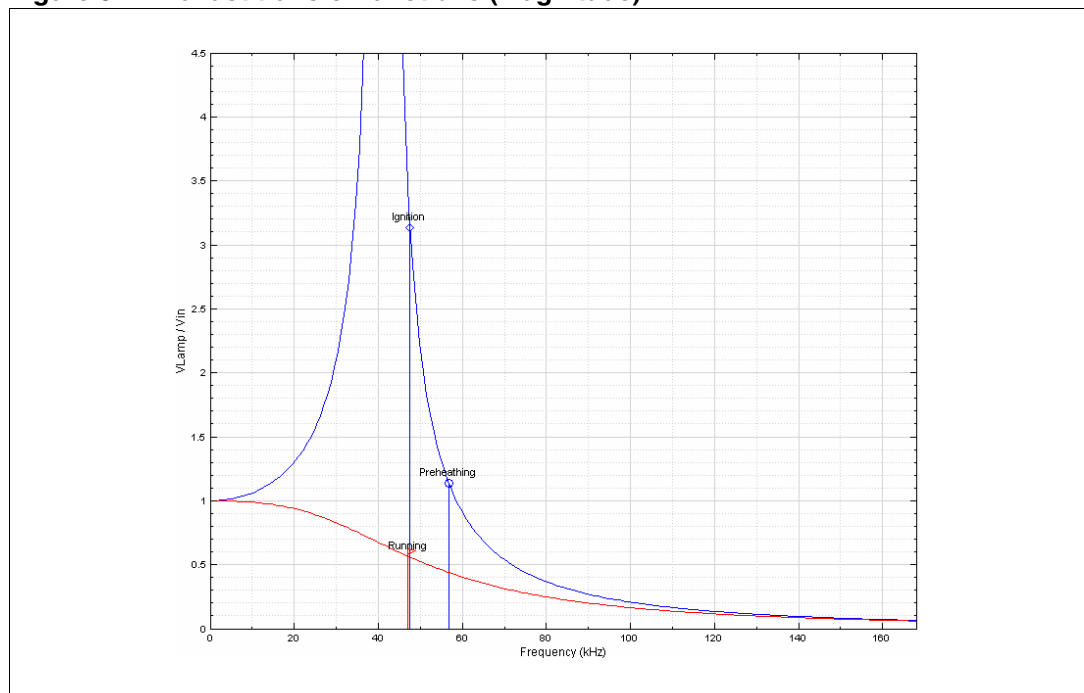

The currents and voltages corresponding to the resulting operating frequencies determine the maximum current and voltage ratings for the inductor, capacitor, and the switches, which, in turn, directly determine the size and cost of the ballast.

Moreover the zero-voltage switching is ensured as shown by the curves above in [Figure 6](#). STP8NM50 (8 A, 550 V) has been selected as power switch according to the current stress and the input DC voltage.

The half-bridge inverter driving circuitry is based on the high performance L6574 which is an OFF-LINE half-bridge driver designed in 600 V BCD technology, including all the features needed to drive and properly control the tubes. A dedicated timing section in the L6574 allows setting the necessary parameters for proper preheat and ignition of the lamps. Also, an op-amp is available to implement closed-loop control of the lamp current during normal lamp burning. To avoid cross conduction of the power MOSFETs the internal logic ensures a minimum deadtime. Moreover the L6574 is provided with two lamp status control functions to protect the application against lamp failure as well as lamp disconnection. Finally it is

possible to modulate the output power in order to allow dimming by varying the switching frequency.

The ballast operating frequencies determine the L6574 biasing circuitry as explained in AN993 "Electronic Ballast With PFC Using L6574 and L6561" and as summarized below.

Table 8. L6574 biasing circuitry design equations for operating conditions

Pin 1 (CPRE)	Pin 2 (RPRE)	Pin 3 (CF)	Pin 4 (RIGN)	Pin 5 (OPOUT)
$T_{ph} = 1.5 \cdot C_{PRE}$ $T_{sh} = \frac{K_{PRE}}{10} \cdot C_{PRE}$	$f_{ph} - f_{run} = \frac{1.41}{R_{PRE} C_f}$	$f_{run} = \frac{1.41}{R_{ign} C_f}$	$f_{run} = \frac{1.41}{R_{ign} C_f}$	<p>A capacitor is connected between this pin and OPIN- for the current feedback loop compensation. It set also the turn on delay in a dimming application.</p>

2.2.1 Lamp dimming

In this system the lamps are dimmed down to 5% by interfacing the ST7FDALI microcontroller with the analog driver L6574.

A PWM output of the ST7FDALI microcontroller is used to generate a 0-5 V PWM at 4 kHz. Its integrated value gives the op amp voltage reference. The dimming level is set by varying the PWM duty cycle from 70% (100% dimming) to 14% (5% dimming). This modification allows changing the L6574 op-amp positive reference voltage from 120 mV to 20 mV which increases the switching frequency and reduces the current in the load.

On the slave unit the duty cycle values have been calculated according the DALI protocol brightness values, listed in [Figure 7](#).

Figure 7. DALI protocol brightness values

n	X	n	X	n	X	n	X	n	X
1	0.100	52	0.402	103	1.620	154	6.520	205	26.241
2	0.103	53	0.414	104	1.665	155	6.700	206	26.967
3	0.106	54	0.425	105	1.711	156	6.886	207	27.713
4	0.109	55	0.437	106	1.758	157	7.076	208	28.480
5	0.112	56	0.449	107	1.807	158	7.272	209	29.269
6	0.115	57	0.461	108	1.857	159	7.473	210	30.079
7	0.118	58	0.474	109	1.908	160	7.680	211	30.911
8	0.121	59	0.487	110	1.961	161	7.893	212	31.767
9	0.124	60	0.501	111	2.015	162	8.111	213	32.646
10	0.128	61	0.515	112	2.071	163	8.336	214	33.550
11	0.131	62	0.529	113	2.128	164	8.567	215	34.479
12	0.135	63	0.543	114	2.187	165	8.804	216	35.433
13	0.139	64	0.559	115	2.248	166	9.047	217	36.414
14	0.143	65	0.574	116	2.310	167	9.298	218	37.422
15	0.147	66	0.590	117	2.374	168	9.555	219	38.457
16	0.151	67	0.606	118	2.440	169	9.820	220	39.522
17	0.155	68	0.623	119	2.507	170	10.091	221	40.616
18	0.159	69	0.640	120	2.577	171	10.371	222	41.740
19	0.163	70	0.658	121	2.648	172	10.658	223	42.895
20	0.168	71	0.676	122	2.721	173	10.953	224	44.083
21	0.173	72	0.695	123	2.797	174	11.256	225	45.303
22	0.177	73	0.714	124	2.874	175	11.568	226	46.557
23	0.182	74	0.734	125	2.954	176	11.888	227	47.846
24	0.187	75	0.754	126	3.035	177	12.217	228	49.170
25	0.193	76	0.775	127	3.119	178	12.555	229	50.531
26	0.198	77	0.796	128	3.206	179	12.902	230	51.930
27	0.203	78	0.819	129	3.294	180	13.260	231	53.367
28	0.209	79	0.841	130	3.386	181	13.627	232	54.844
29	0.215	80	0.864	131	3.479	182	14.004	233	56.362
30	0.221	81	0.888	132	3.576	183	14.391	234	57.922
31	0.227	82	0.913	133	3.675	184	14.790	235	59.526
32	0.233	83	0.938	134	3.776	185	15.199	236	61.173
33	0.240	84	0.964	135	3.881	186	15.620	237	62.866
34	0.246	85	0.991	136	3.988	187	16.052	238	64.607
35	0.253	86	1.018	137	4.099	188	16.496	239	66.395
36	0.260	87	1.047	138	4.212	189	16.953	240	68.233
37	0.267	88	1.076	139	4.329	190	17.422	241	70.121
38	0.275	89	1.105	140	4.449	191	17.905	242	72.062
39	0.282	90	1.136	141	4.572	192	18.400	243	74.057
40	0.290	91	1.167	142	4.698	193	18.909	244	76.107
41	0.298	92	1.200	143	4.828	194	19.433	245	78.213
42	0.306	93	1.233	144	4.962	195	19.971	246	80.378
43	0.315	94	1.267	145	5.099	196	20.524	247	82.603
44	0.324	95	1.302	146	5.240	197	21.092	248	84.889
45	0.332	96	1.338	147	5.385	198	21.675	249	87.239
46	0.342	97	1.375	148	5.535	199	22.275	250	89.654
47	0.351	98	1.413	149	5.688	200	22.892	251	92.135
48	0.351	99	1.452	150	5.845	201	23.526	252	94.686
49	0.371	100	1.492	151	6.007	202	24.177	253	97.307
50	0.381	101	1.534	152	6.173	203	24.846	254	100.000
51	0.392	102	1.576	153	6.344	204	25.534		

To avoid the presence of stationary waves along the tubes at minimum dimming level, a resistor of 100 kΩ / 2 W has been placed in parallel to the battery capacitor of each lamp. The resistance value ensures an additional current of 2 mA on the cathodes without affecting the ballast efficiency.

Finally, during the startup sequence the frequency always goes from fmax to fmin, independently of the set dimming level. Only after lamp turn-on does the frequency move towards higher values.

2.2.2 Supply section

To supply the DALI slave microcontroller an AC-DC buck converter based on the VIPer12A-E and L78L05 has been implemented on the ballast board. It converts the rectified and filtered mains to a 5 V regulated output voltage dedicated to the microcontroller. The converter works in discontinuous current mode adjusting the duty cycle

of the VIPer12A-E power switch in order to deliver the energy from the input to the output by means of an inductor. PWM driver, power switch, thermal and overcurrent protection are integrated in the same silicon chip ensuring minimum size and good performances at very low cost.

Thanks to this implementation strategy the microcontroller is always supplied, allowing the lamps to turn on, even when L6562 and L6574 are in a latched shutdown state.

The startup procedure is very important in an application that contains two different sections. The ballast section starts before the PFC, avoiding any extra voltage at the PFC section output, and consequently the L6562 OVP activation. This behavior is guaranteed under all conditions because the VS turn-on threshold of L6574 is lower than that of the L6562. The turn-on threshold is reached by a resistor chosen in order to ensure the startup current of both the L6562 and the L6574. When the ballast section is running, the charge pump (C11, R14, D3 and DZ1) supplies both the devices and the filter R17-C10 allows to reduce the noise at Vcc.

2.2.3 Lamp turn-on and lamp turn-off

To get low-power consumption (less than 0.6 W) during the lamps' turnoff state, both the half-bridge and the PFC have to be disabled, even in the presence of the mains at the ballast input. To manage this standby condition the L6574 control section and the L6562 ZCD pin are interfaced with the DALI slave microcontroller.

Short pulses (> 200 nsec) at the EN1 and EN2 inputs are recognized by the L6574. In particular, EN1 high (> 0.6 V) stops all the half-bridge functions and puts the L6574 in a latched shutdown state. At the same time, by forcing externally the ZCD pin to a voltage below 150 mV, the L6562 is stopped. To cancel this status, in order to turn on the lamps, a pulse (>0.6 V) is sent by the microcontroller to the L6574 second control pin EN2 and the ZCD pin external pull down is removed. The half-bridge driver restarts the preheating and ignition procedure, and the L6562 performs again its operation. The controls timing diagram is shown in [Figure 8](#).

Figure 8. Ballast controls timing chart

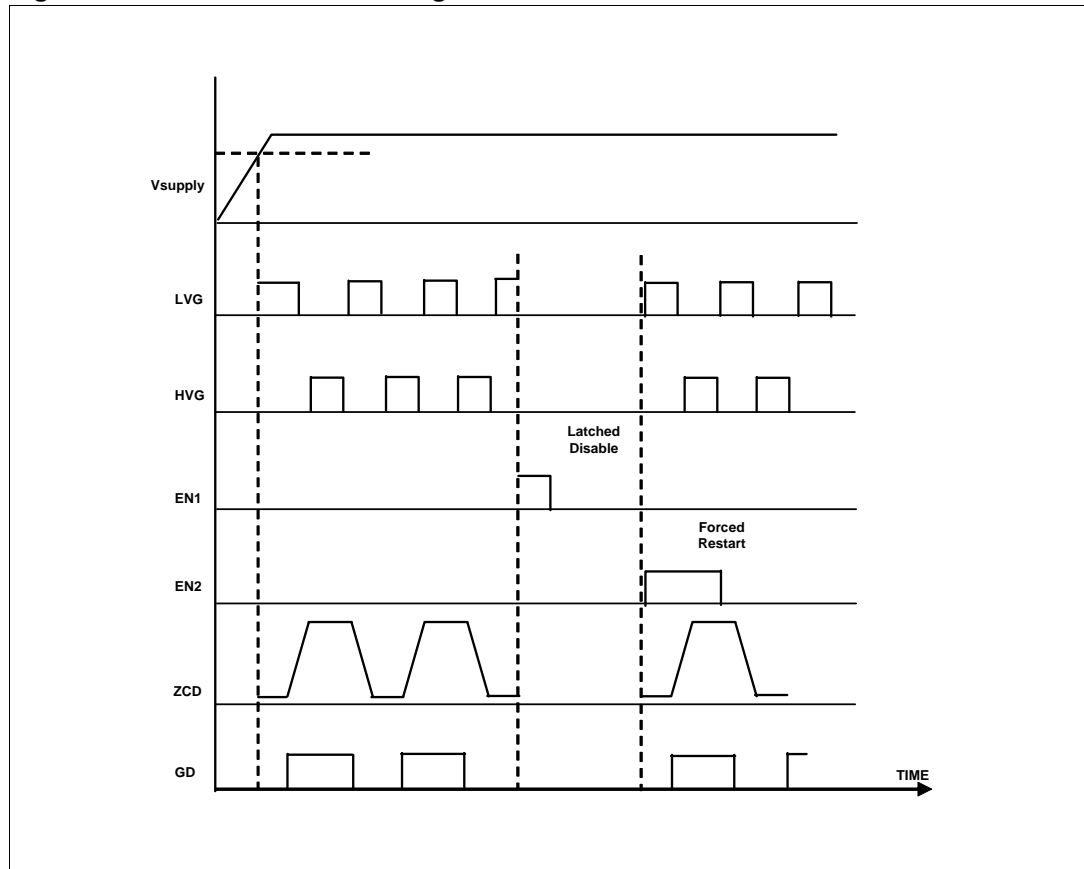

On the slave unit the turning ON/OFF process is implemented by setting the pins PB3 (EN1) and PB4 (EN2) as output pull-up, while PB2 (ZCD) as output open drain. The three corresponding bits in the port data register are clear by software. To "switch on" the ballast, a pulse must be sent to PB4 (EN2 signal) and the third bit must be set in the port B (ZCD) data register. To "switch off" the ballast, a pulse must be sent to PB3 (EN1 signal) and the third bit must be cleared in the port B (ZCD signal) data register.

Figure 9, 10, and 11 show the idle state and the turn-on/off commands.

Figure 9. Idle state

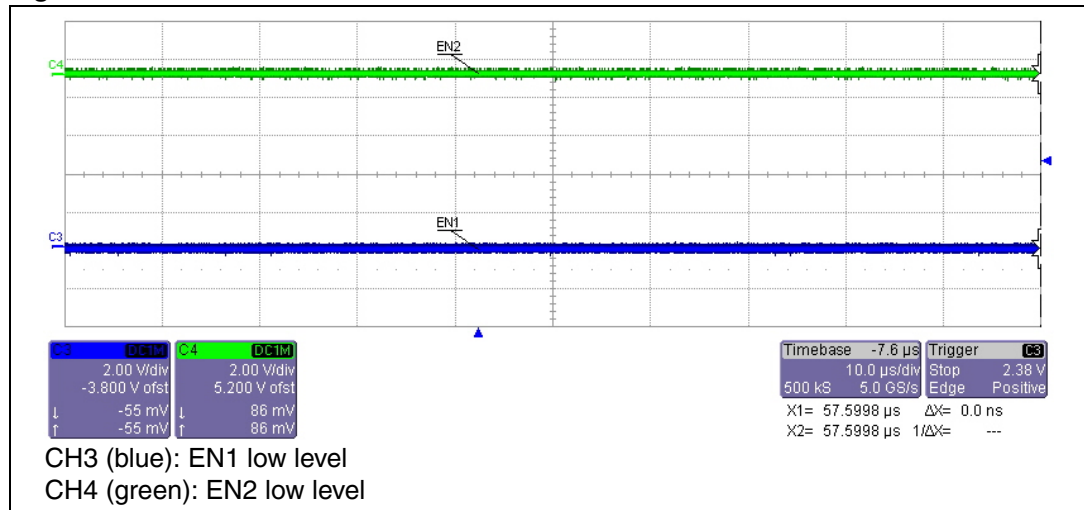

Figure 10. Turn-on procedure

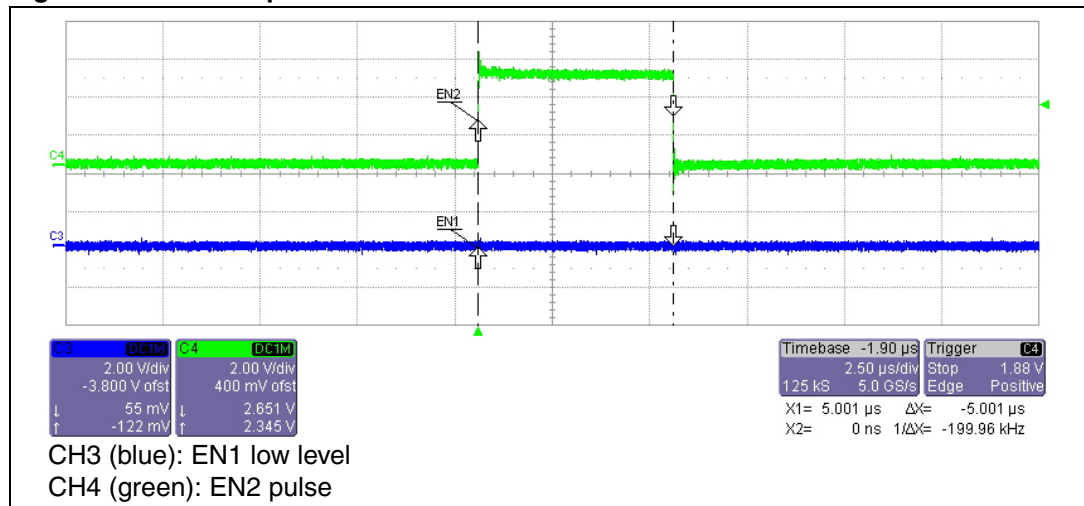
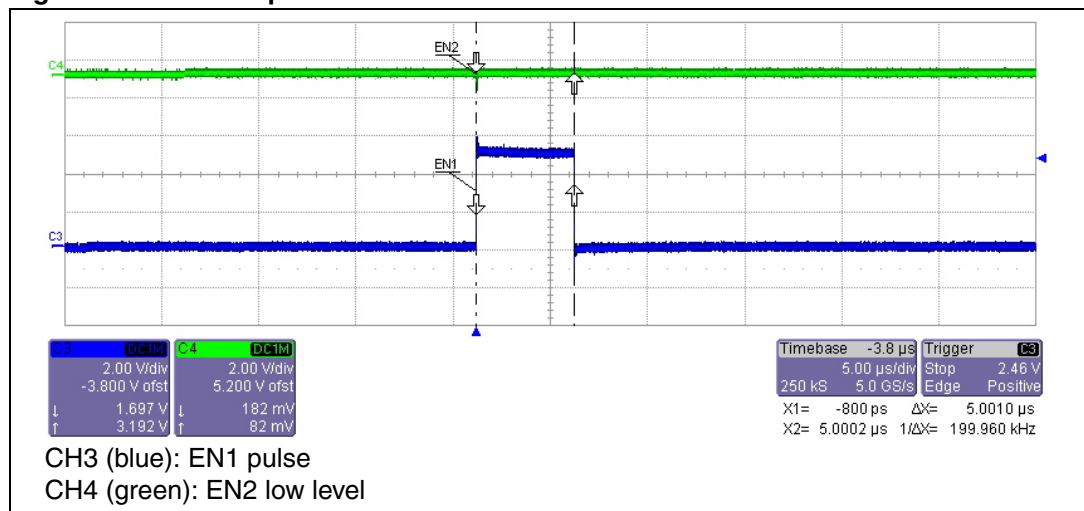

Figure 11. Turn-off procedure



2.2.4 Verification of lamp status

This function detects a lamp disconnection or a lamp failure on the slave board. The microcontroller performs a double check: one on the PB1 pin for the lamp hardware status and one on the flag "LAMP_ARC_POWER_ON" for the lamp software status. If the PB1 logical level is low and the flag is true, lamp disconnection happened. The condition is recorded on ST7FDALI, so when the microcontroller receives a "query frame" from the master, it changes the PB3 (EN1) and PB4 (EN2) configuration from input to output, and sends a byte answer as 'STATUS INFORMATION' described below:

- bit 0 status of ballast; '1'= NOK
- bit 1 Lamp failure; '1'= NOK
- bit 2 Lamp arc power on; '0' = OFF
- bit 3 Query: Limit Error; '0' = Last requested arc power level is between MIN..MAX LEVEL or OFF
- bit 4 Fade ready; '0' = fade is ready; '1' = fade is running
- bit 5 Query: 'RESET STATE'? '0' = 'No'
- bit 6 Query: Missing short address? '0' = 'No'
- bit 7 Query: 'POWER FAILURE'? '0' = 'No'; 'RESET' or an arc power control command has been received after last power-on

When the master receives this frame, it displays the lamp status by means of two LEDs (green stands for ok, red for status not ok). Once the failure condition has been detected and solved, an "ON" command has to be sent to the slave, allowing the master's microcontroller to toggle again the LED status from red to green. From the analog side, to detect a disconnection or a failure event for each lamp, two signal Schottky diodes have been used to bias the EN1 or EN2 pin of L6574. The failure condition is detected both at startup and when running.

The forward and backward frame timing is shown in [Figure 12](#) and [13](#):

Figure 12. Forward frame timing

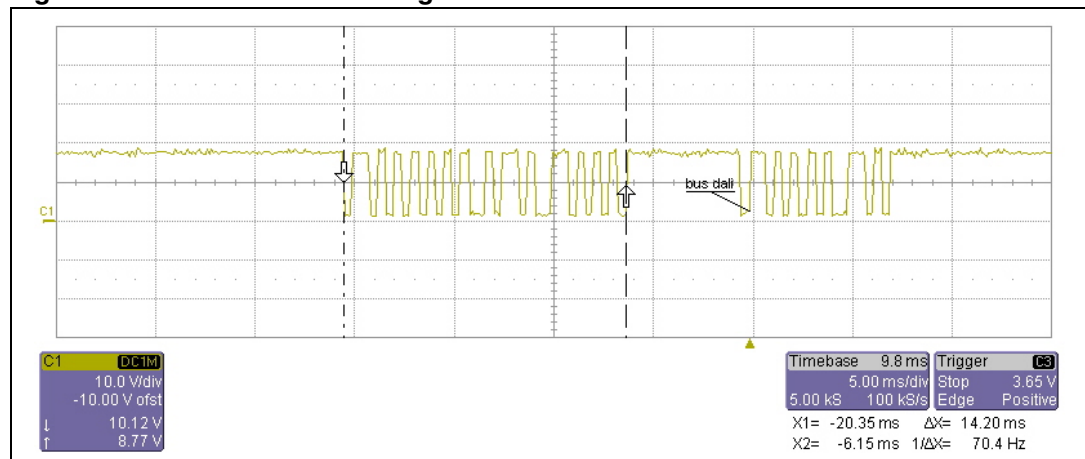
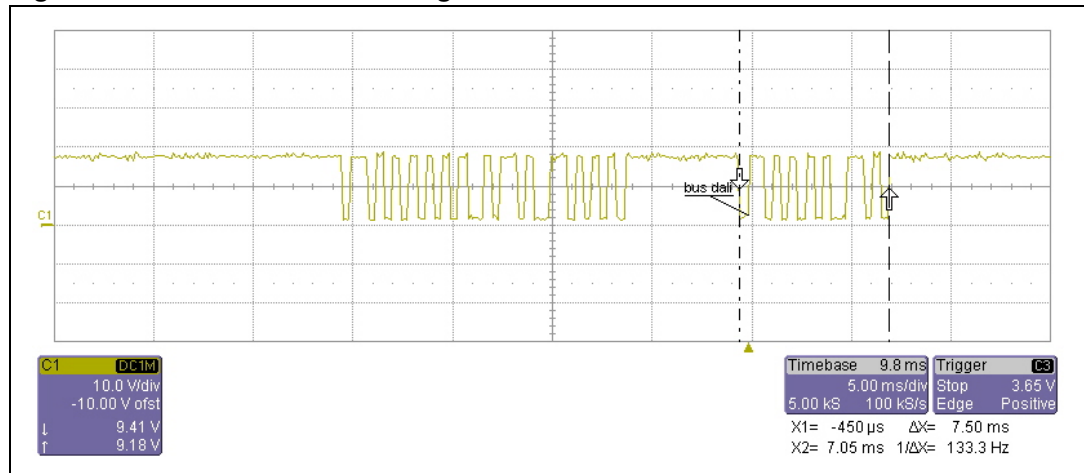

Figure 13. Backward frame timing



The forward as well as the backward frame duration is the same for all kinds of commands.

2.2.5 Ballast performances

In this section the main ballast waveforms are shown.

Figure 14. Ballast startup at 230 Vac-full power

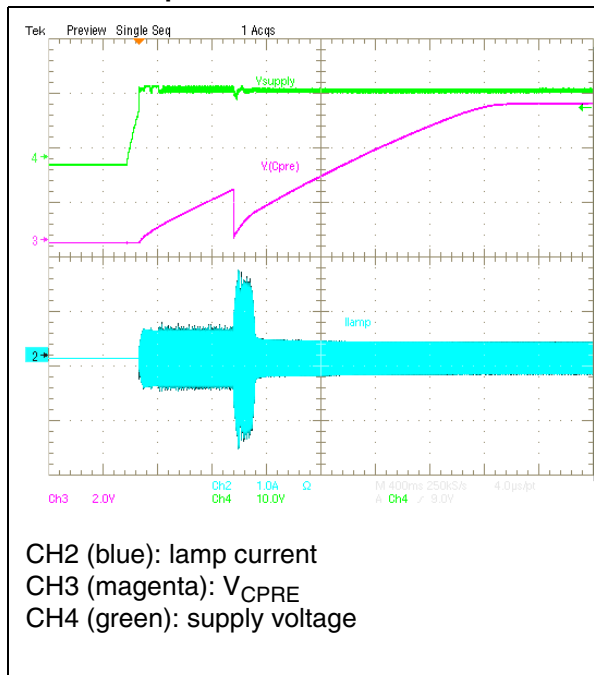

Figure 15. Lamps turn-on at 230 Vac-full power

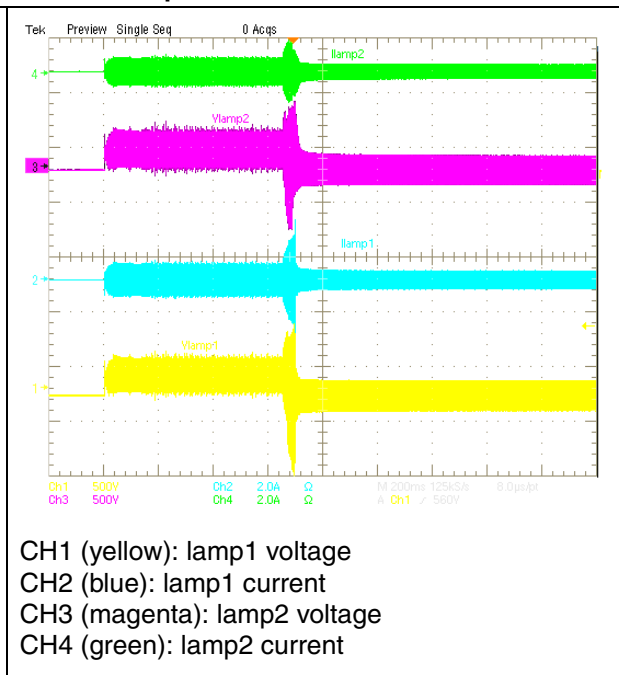

Figure 16. Lamps running at 230 Vac - full power

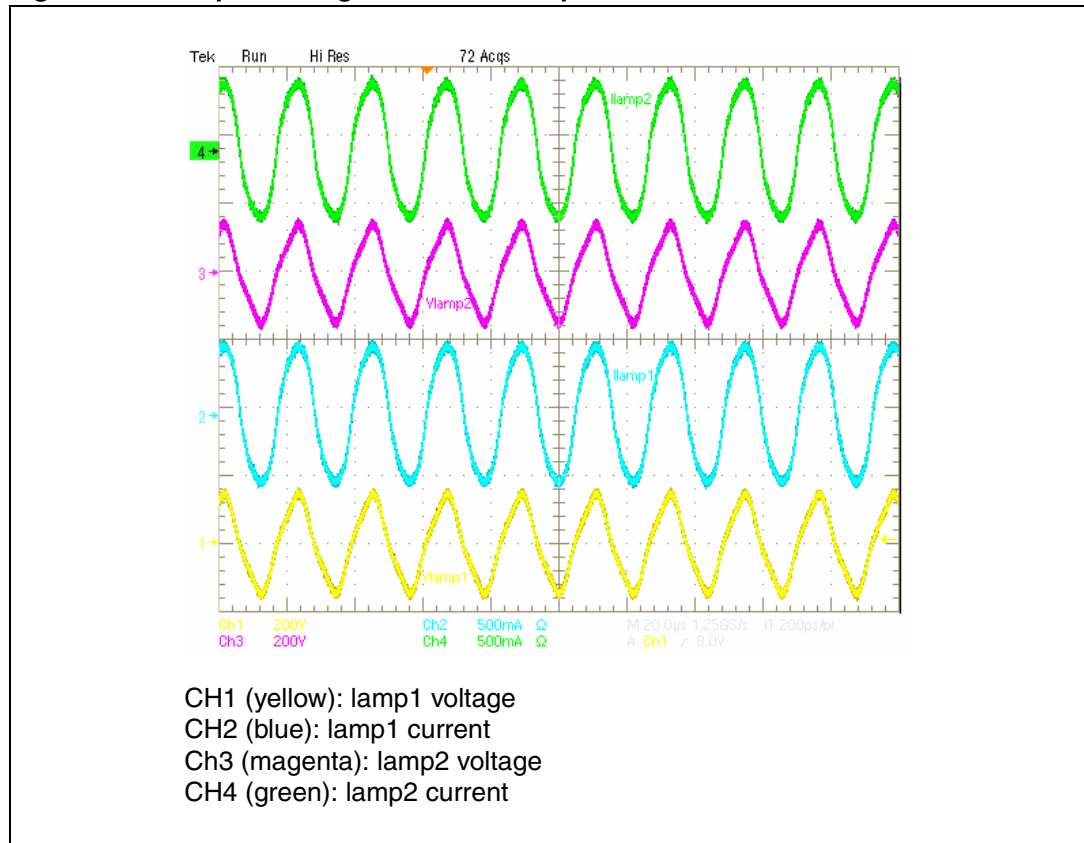

Table 9. Ballast performances

Vin (Vac)	Pin (W)	PF	THD (%)	Po (W)	η(%)
90	76.5	0.999	3.9	66	86.2
110	75.5	0.999	3.6	66	87.4
140	74.2	0.998	5.5	66	89
176	73.7	0.997	7.2	66	90
230	73	0.997	7.3	66	90
265	72.8	0.996	8.3	66	91

The efficiency of the system is a little bit lower than a standard HF ballast due to the supply section of the slave and the resistors in series to the lamp's cathode used to ensure a minimum current at low dimming level.

3 DALI master unit

The ST2C334J4 microcontroller is used as master, implementing the DALI Peripheral via software.

The communication master-slave uses a 20 V bus. To adapt the TTL level of the microcontroller to the communication bus level, two opto-couplers and a NPN transistor BC-817 have been used.

The RS232 interface with ST232C is available on the board to implement the SCI communication as an option. This option expects the use of a PC to address the ballast either with broadcast or group or single mode thanks to a GUI called (DALI Power Control).

The DALI master unit has been thought of as a standalone solution. In fact it is provided with a keyboard to manage the DALI commands, to address the slaves and to display the lamps' status.

The keyboard is made up of 16 push buttons controlled by means of a matrix representation. In particular the first four pins of PORTD are associated to the rows and the first four pins of PORTB to the columns.

The check of the keyboard is implemented as a loop mode by clearing the PDDR register port and setting the PBDR register port sequentially. When a button is pressed, the pin of the port B corresponding to the interested column goes down and this condition is taken over by an interrupt condition. Inside the interrupt routine, a read procedure of the port registers PDDR and PBDR is expected and by this information the pressed button is acknowledged. The "press button" procedure is described by [Figure 17](#) and [18](#).

Figure 17. Polling keyboard

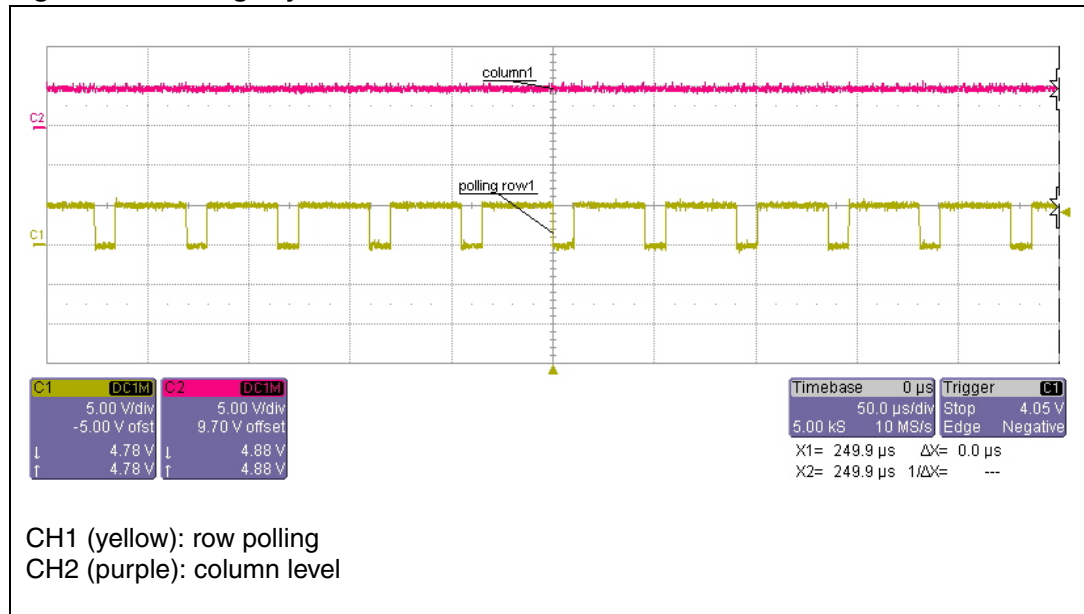
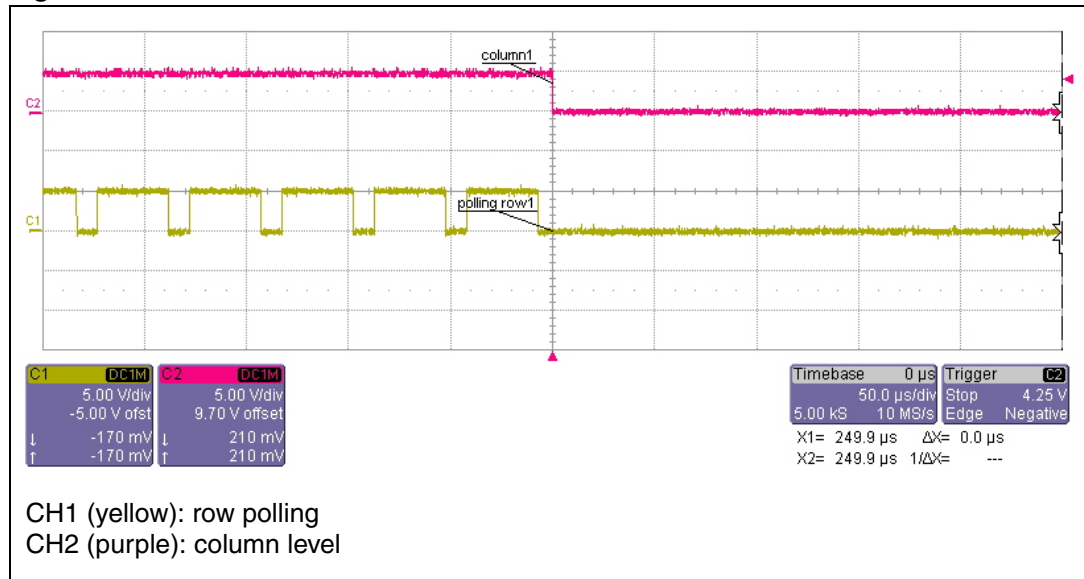

Figure 18. Pressed button event



3.1 Master unit schematic and bill of material

The schematic of the master unit is shown in [Figure 19](#).

Figure 19. Master unit schematic

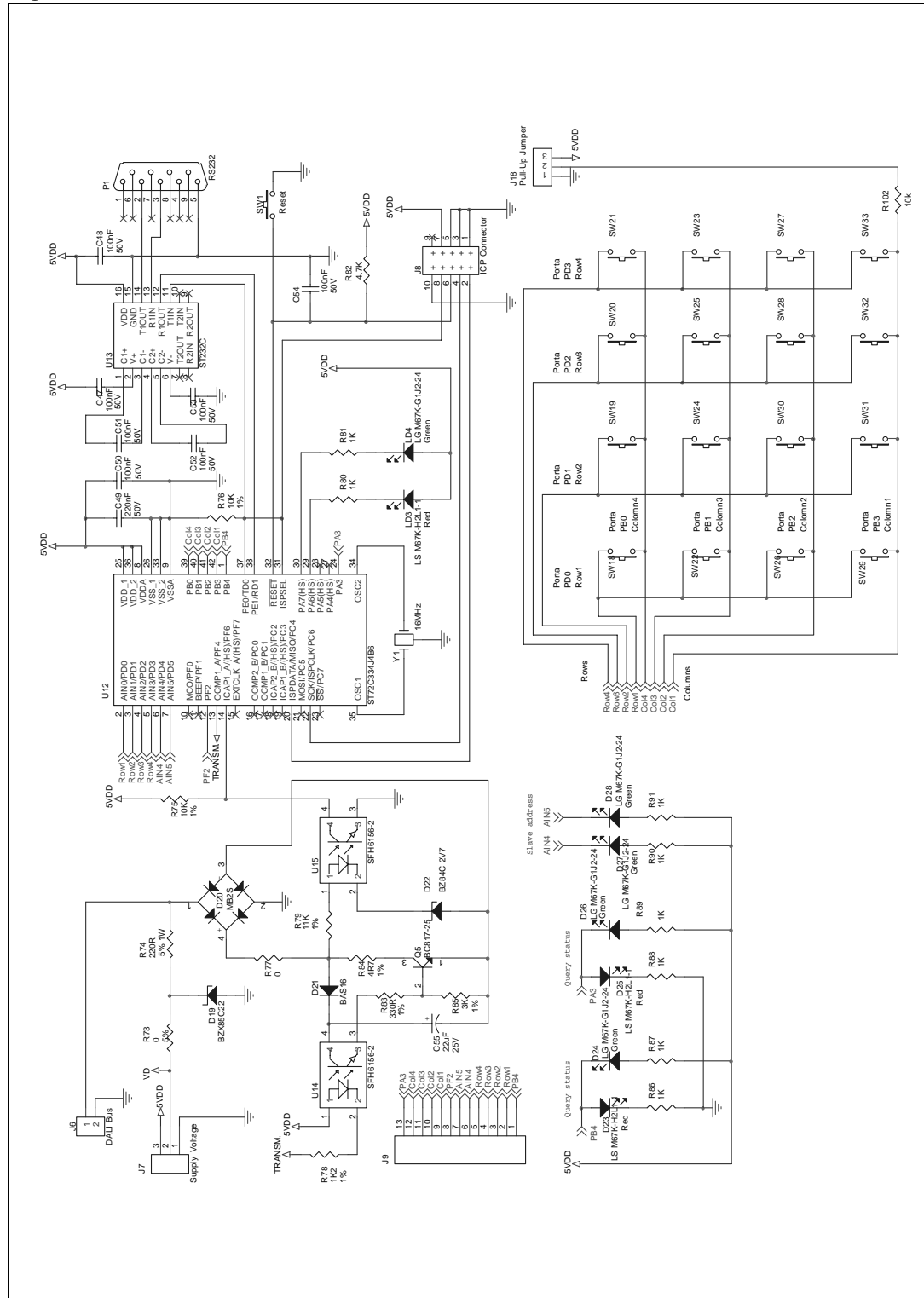

Table 10. Master unit bill of material

Reference	Value	Description
C47,C48,C50,C51,C52,C53,C54	100 nF 50 V	Ceramic capacitor SMD 0805
C49	220 nF 50 V	Ceramic capacitor SMD 0805
C55	22 μ F 25 V	Tantalum capacitor SMD
D19	BZX85C22	22 V 0.5 W Zener diode
D20	MB2S	SMD bridge rectifier
D21	BAS16	SMD diode
D22	BZ84C 2V7	2.7 V 0.5 W Zener SMD diode
D23,D25	LS M67K-H2L1-1	Red SMD LED 2 mA, 0805
D24,D26,D27,D28	LG M67K-G1J2-24	Green SMD LED 2 mA, 0805
J6	DALI BUS	2-way single row, header shrouded
J7	Supply voltage	3-way single row header shrouded
J8	ICP connector	10-way 2-row vertical through-hole boxed header, 2.54 mm pitch/grid
J9		13-way strip line connector (not mounted)
J12	Pull-up jumper	3-way strip line connector
LD3	LS M67K-H2L1-1	Red SMD LED 2 mA, 0805
LD4	LG M67K-G1J2-24	Green SMD LED 2 mA, 0805
P1	Serial connector	9-way 90° PCB mount D plug
Q5	BC817-25	SMD NPN transistor
R73	0	Resistor SMD 1206
R77	0	Resistor SMD 0805
R74	220 Ω	1 W 5% resistor
R75,R76	10 k Ω	1% resistor SMD 0805
R78	1.2 k Ω	1% resistor SMD 0805
R79	11 k Ω	1% resistor SMD 0805
R80,R81	1 k Ω	Resistor SMD 0805
R82	4.7 k Ω	Resistor SMD 0805
R83	330 Ω	1% Resistor SMD 0805
R84	4.7 Ω	1% Resistor SMD 0805
R85	3 k Ω	1% Resistor SMD 0805
R86,R87,R88,R89,R90,R91	1 k Ω	Resistor SMD 0805
R101	10 k Ω	Resistor SMD 0805
SW1	Reset	THT button

Table 10. Master unit bill of material (continued)

Reference	Value	Description
SW2, SW3, SW4, SW5, SW6, SW7, SW8, SW9, SW10, SW11, SW12, SW13, SW14, SW15, SW16, SW17	Keyboard	THT button
U12	ST72C334J4B6 PSDIP42	STMicroelectronics 8-bit MCU with single voltage flash memory, Adc, 16-bit timers, SPI, SCI interface
U13	ST232C SOP	STMicroelectronics 5 V powered multi-channel RS-232 drivers and receivers
U14,U15	SFH6156-2	SMD Opto-coupler
Y1	16 MHz	Oscillator

Note: Resistors are 0.25 W unless specified

4 Basics of DALI

DALI stands for "Digital Addressable Lighting Interface". It is a standard interface for lighting control solutions, defined by the main lighting manufacturers and standardized as IEC 929.

The DALI protocol is implemented on a master-slave architecture.

It uses the bi-phase Manchester asynchronous serial data format. All the bits of the frame are bi-phase encoded except the two stop bits. Following are some of the standard features:

- Transmission rate at 1.2 kHz.
- Bi-phase bit period is $833.33 \mu\text{S} \pm 10\%$.

A forward frame consists of 19 bi-phase encoded bits:

- 1 start bit (0->1: logical '1')
- 1 address byte (8-bit address)
- 1 data byte (8-bit data)
- 2 high level stop bits (no change of phase)

A backward frame consists of 11 bi-phase encoded bits:

- 1 start bit (0->1: logical '1')
- 1 data byte (8-bit data)
- 2 high level stop bits (no change of phase)

Each frame has 2 stop bits which do not contain any change of phase.

The setting time between two subsequent forward frames is 9.17 ms (minimum), while the delay between forward and backward frame goes from 2.92 ms to 9.17 ms. If a backward frame has not been started after 9.17 ms, this is interpreted as "no answer".

In the event of code violation, the frame is ignored and the system is ready again for data reception.

The main advantages of the DALI system can be summarized as follows:

- Simple wiring: all of the units in the system are interconnected using a simple five-core cable.

Figure 20. Cable wiring

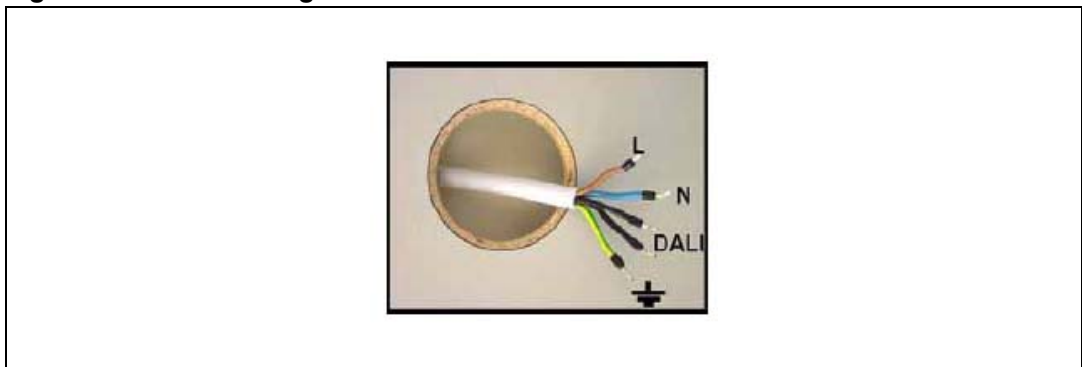

- No mains switching required: lamps can be dimmed or switched on and off using control system commands without any need for mains switching.
- Easy system re-configuration: the configuration of the system can be changed quickly without any modification to the hardware.
- Easy system modification: if the lighting system needs to be enlarged, new components can be added anywhere on the DALI cable.
- It is possible to define light scenes. A scene means a particular light level intensity. 16 scenes can be defined at maximum.

Figure 21. Master flowchart

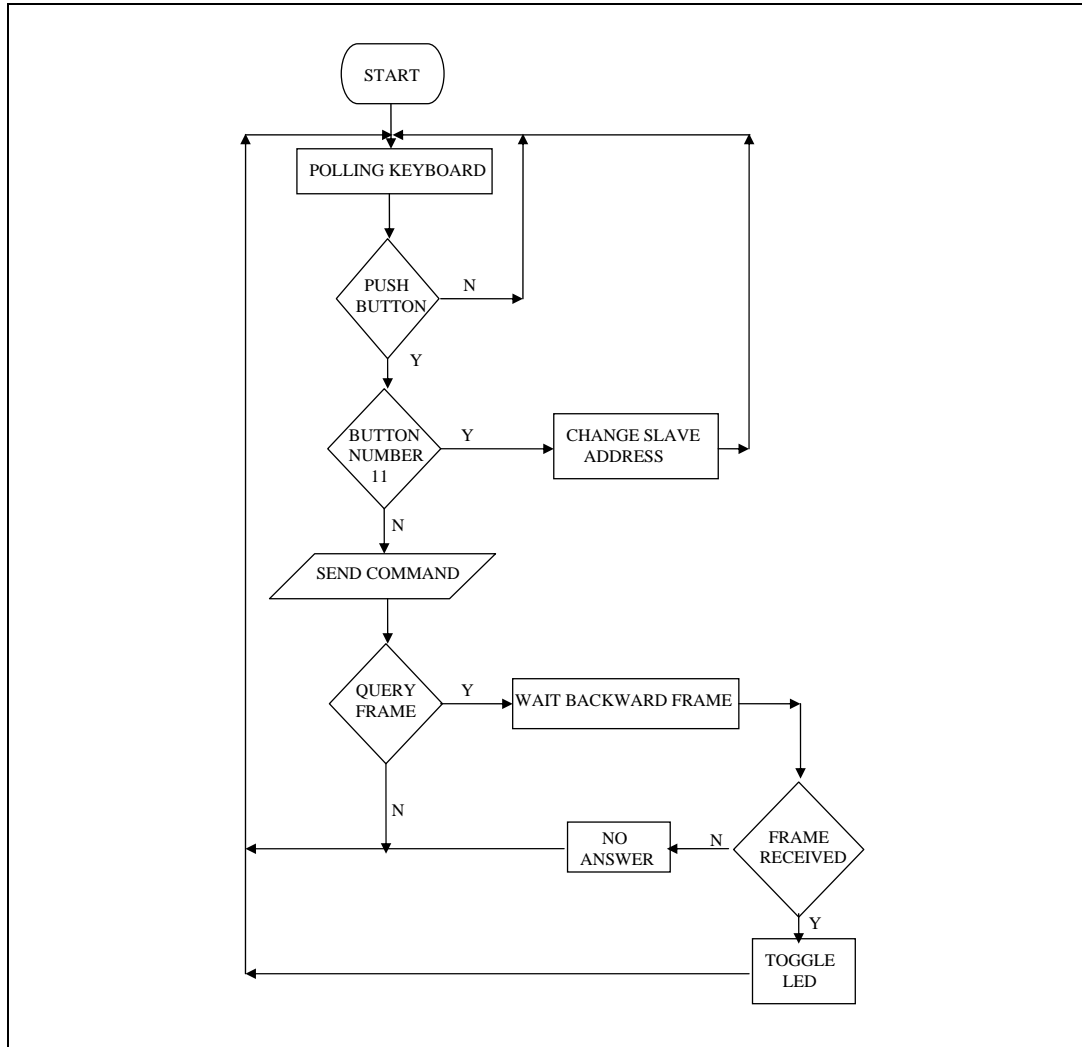
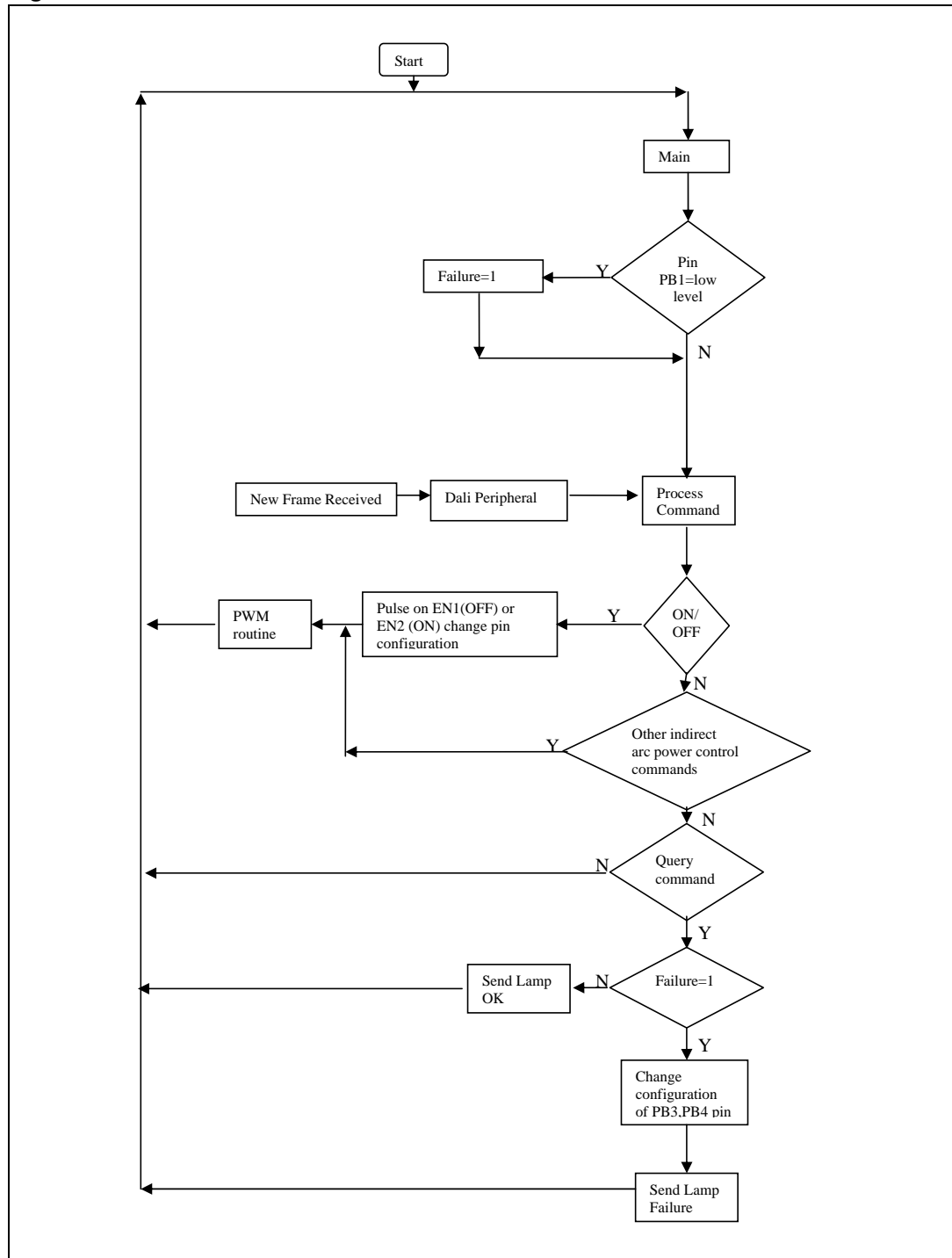

Figure 22. Slave flowchart



5 DALI master AC-DC adapter

This is an offline wide-range double-output SMPS based on the VIPer12A-E. The first output, 20 V at 100 mA, is dedicated to the bus communication allowing to address up to 64 slaves, while the second one delivers 5 V at 10 mA to the MASTER DALI microcontroller thanks to a linear post-regulator.

The VIPer12A-E combines on the same silicon chip a dedicated current mode PWM controller, a high voltage power MOSFET and the protection features (thermal, overcurrent, and overvoltage) which increases the converter reliability and saves size, parts count and cost.

The converter topology is an isolated flyback designed to work in discontinuous current mode according to the following specifications:

Table 11. SMPS operating conditions

Parameter	Value
Input voltage range	90 – 265 Vac
Input frequency range	50/60 Hz
Output voltage 1	V1=20 V
Output voltage 2	V2=5 V
Output current 1	I1=100 mA
Output current 2	I2=10 mA
Output power (peak)	2.2 W
Line regulation	+/- 1%
Load regulation	+/- 1%
EMI	EN55015

5.1 Adapter description

The schematic of the board is shown in [Figure 23](#).

The AC input is rectified by the diodes bridge and then filtered by the bulk capacitor C1, and C2 to generate the high voltage DC.

The input EMI filter is a simple CLC PI filter for both differential and common mode noise suppression.

An NTC limits the inrush current and ensures a reliable operation of the bridge at startup.

The switching frequency is fixed at 60 kHz by the IC internal oscillator allowing optimization of the transformer size and cost. An RCD snubber circuit (R92, C59, D30) reduces the leakage inductance voltage spike and the voltage ringing on the drain pin of VIPer12A-E.

As soon as the voltage is applied on the input of the converter the high voltage startup current source connected to the drain pin is activated and starts to charge the Vdd capacitor C8 by a constant current of 1mA. When the voltage across this capacitor reaches the Vddon threshold (about 14 V) the VIPer12AS-E starts to switch. During normal operation the smart

power IC is powered by the auxiliary winding of the transformer via the diode D31. No spike killer for the auxiliary voltage fluctuations is needed thanks to the wide range of the V_{DD} pin (9-38 V). The primary current is measured using the integrated current sensing for current mode operation.

The output rectifier D29 has been chosen in accordance with the maximum reverse voltage and power dissipation. In particular a 1 A - 150 V power Schottky, type STPS1150, has been selected.

The output voltage regulation is performed by secondary feedback on the 20 V output while the 5 V output, is linearly post-regulated from the 20 V output. This operation is performed by a low drop voltage regulator, L78L05CZ, in the TO92 package. The feedback network consists of a programmable voltage reference, TL431, driving an optocoupler which ensures the required insulation between the primary and secondary sections. The optotransistor drives directly the VIPer12A-E feedback pin which controls the operation of the IC.

A small LC filter has been added on the 20 V output in order to reduce the high frequency ripple with reasonable output capacitor value.

The flyback transformer is a layer type based on the EF13 core and Fi 324 ferrite, manufactured by Vogt, and ensures safety insulation in accordance with the EN60950.

[Figure 26](#) shows the main features of the transformer. The power supply has been implemented on a double-sided 35 μ m PCB in FR-4, sizing 81 x 37 mm.

Figure 23. Adapter schematic

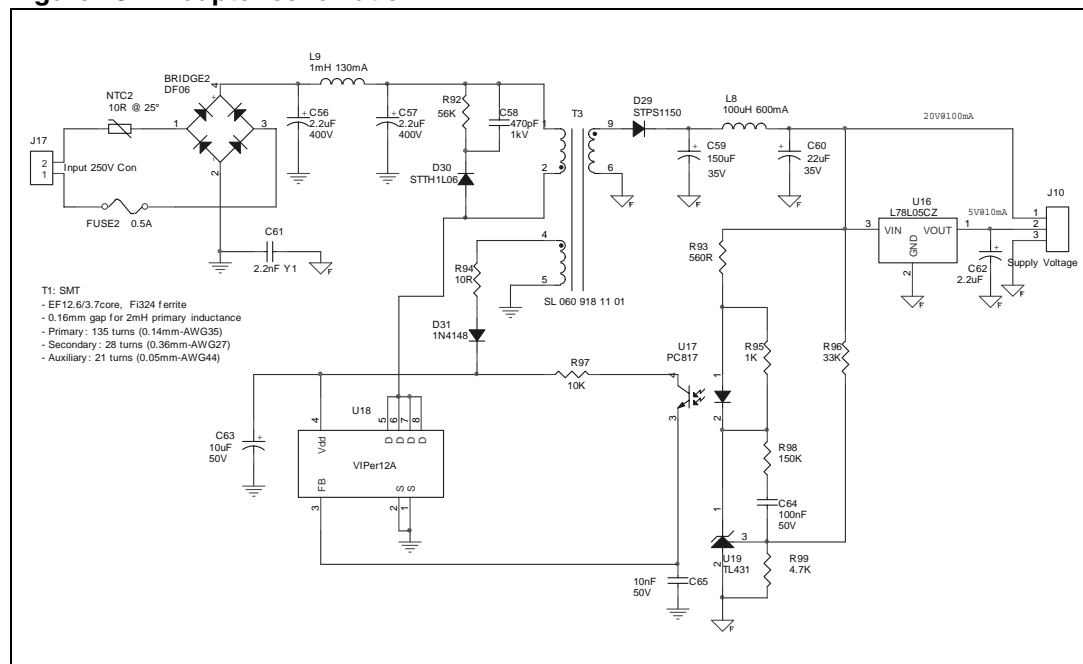

Figure 24. Adapter PCB layout - top side - silkscreen (to scale)

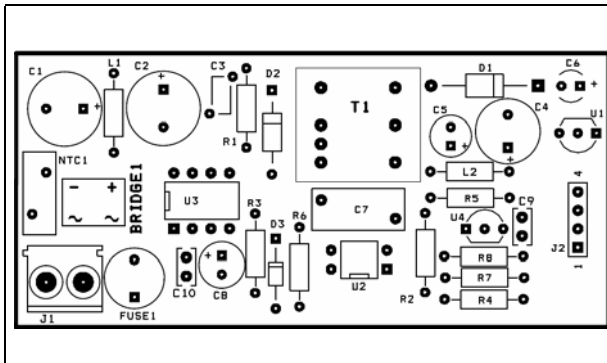

Figure 25. Adapter PCB layout - bottom side - copper tracks (to scale)

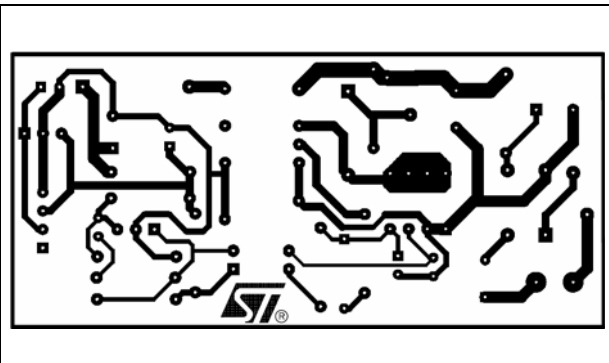
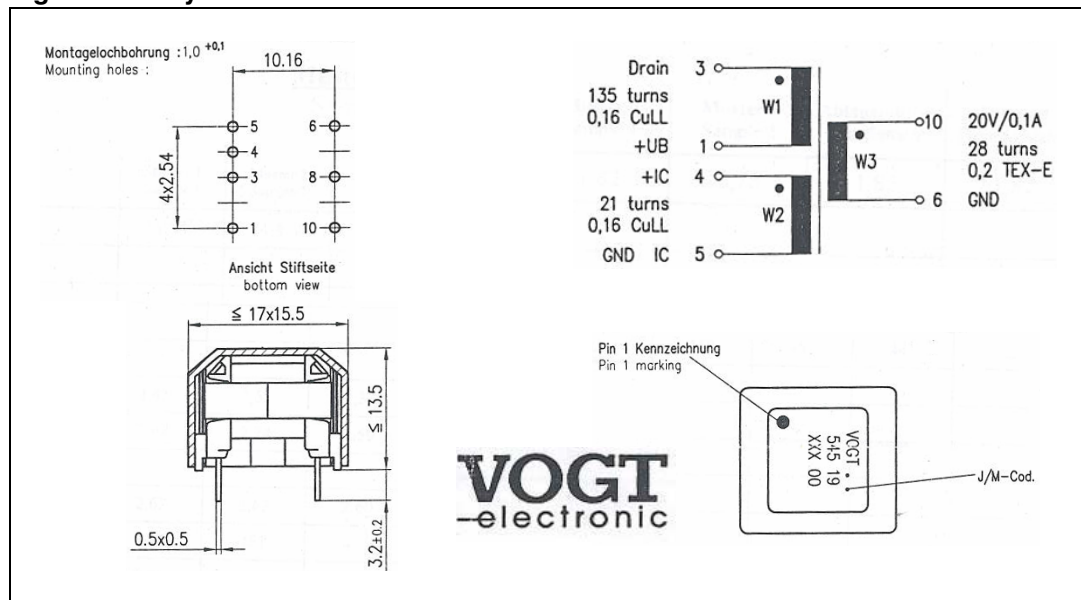

Figure 26. Flyback transformer



- Operating switching frequency: 60 kHz
- Core geometry: EF 12.6/3.7
- Core material: FI 324 or equivalent
- Primary inductance value: 2 mH
- Leakage inductance: 75 μH
- Air gap length: 0.16 mm
- Safety: EN60950

5.2 Adapter bill of material

Table 12. Adapter bill of material

Reference	Value	Description
BRIDGE2	DF06M 1 A 600 V	Bridge rectifier
C56,C57	2.2 μ F 400 V	Electrolytic cap
C58	470 pF 1 kV	Ceramic cap
C59	150 μ F 35 V	Low ESR electrolytic cap
C60	22 μ F 35 V	Low ESR electrolytic cap
C61	2.2 nF Y1	Y1 ceramic cap
C62	2.2 μ F 25 V	Electrolytic cap
C63	10 μ F 50 V	Electrolytic cap
C64	100 nF 50 V	Ceramic cap
C65	10 nF 50 V	Ceramic cap
D29	STPS1150	STMicroelectronics power Schottky rectifier 1 A 150 V
D30	STTH1L06	STMicroelectronics ultrafast high-voltage rectifier 1 A 600 V
D31	1N4148	Small signal rectifier 200 mA 100 V
FUSE2	0.5 A	Radial fuse
J10	Supply voltage	3-way single row shrouded header
J11	Input 250 V connector	2-way PCB screw terminal, 5.08 mm
L8	100 μ H 600 mA	Axial inductor
L9	1 mH 130 mA	Axial inductor
NTC2	10 Ω @ 25°	Inrush current suppressor
R92	56 k Ω	Resistor, metal film 0.25 W
R93	560 Ω	Resistor, metal film 0.25W
R94	10 Ω	Resistor, metal film 0.25 W
R95	1 k Ω	Resistor, metal film 0.25 W
R96	33 k Ω	Resistor, metal film 0.25 W
R97	10 k Ω	Resistor, metal film 0.25 W
R98	150 k Ω	Resistor, metal film 0.25 W
R99	4.7 k Ω	Resistor, metal film 0.25 W
T3	SL 060 918 11 01	VOGT SMT
U16	L78L05CZ TO92	STMicroelectronics positive voltage regulator
U17	PC817	Sharp Optocoupler 5 kV
U18	VIPer12A-E DIP8	STMicroelectronics offline SMPS primary IC 730 V 0.4 A 27 Ω
U19	TL431 TO92	STMicroelectronics programmable voltage reference

5.3 Adapter performances

Several tests have been performed on the board to evaluate the converter behavior in terms of efficiency, stability, safe operating area of the devices, line & load regulation and EMI performances.

5.3.1 Steady state tests

These tests have been performed at the input voltage of 110 Vac and 230 Vac at full and minimum load condition.

Figure 27. VIPer12A-E steady state behavior at full load at 110 Vac - 60 Hz

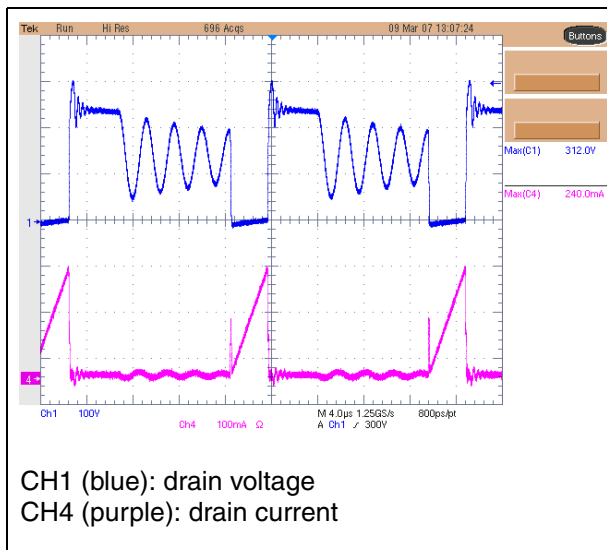
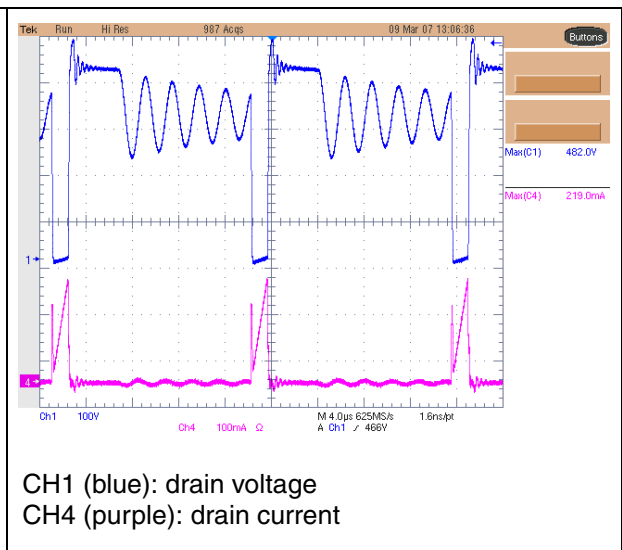

Figure 28. VIPer12A-E steady state behavior at full load at 230 Vac - 50 Hz



As shown by the waveforms the power supply operates in discontinuous current mode.

Figure 29. VIPer12A-E steady state behavior at minimum load at 110 Vac - 60 Hz

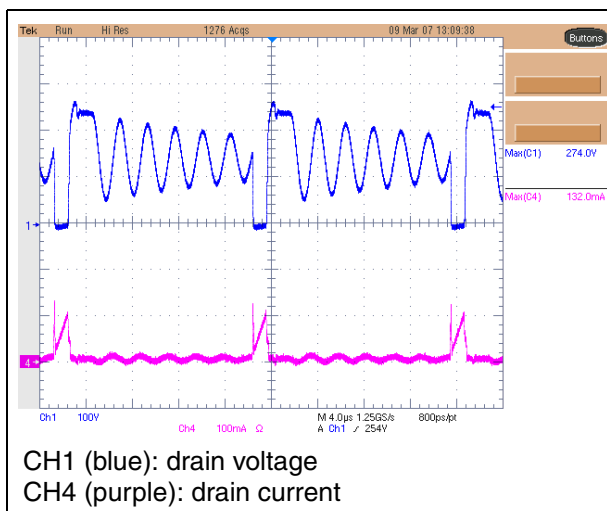
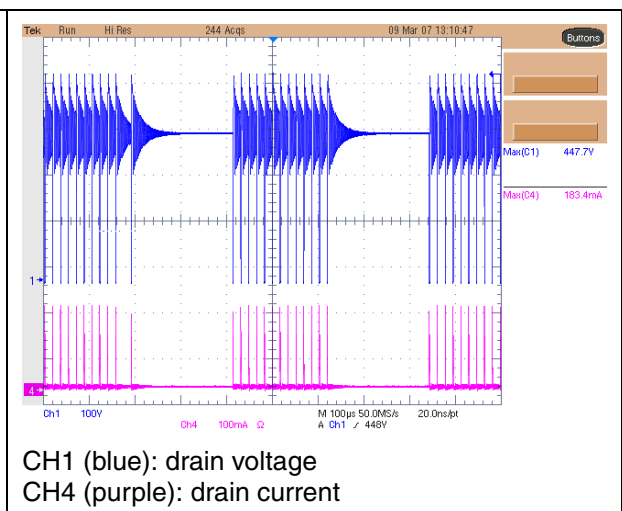

Figure 30. VIPer12A-E steady state behavior at minimum load at 230 Vac - 50 Hz



At minimum load the VIPer12A-E ensures the burst mode operation, saving the input power consumption.

5.3.2 Startup behavior

Figure 31, 32, 33, and 34 show the typical waveforms during the startup of the power supply. In particular, the full load condition is considered since it represents the heaviest case in terms of voltage and current stress, as well as the minimum load condition for loop stability and voltage stress.

Figure 31. Startup waveforms at full load at 110 Vac - 60 Hz

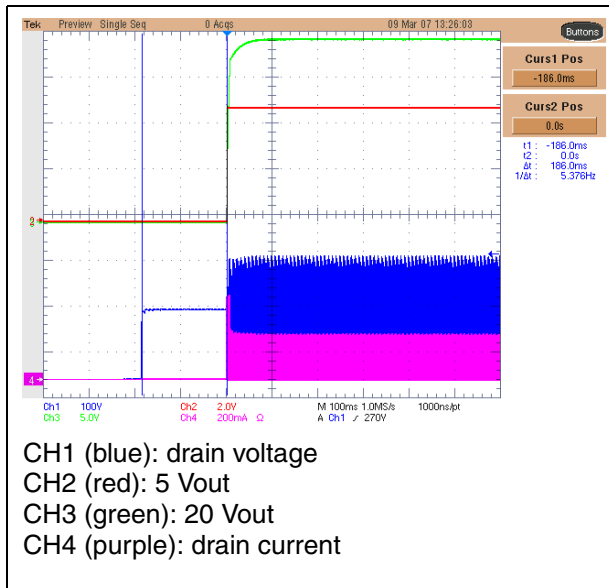

Figure 32. Startup waveforms at full load at 230 Vac - 50 Hz

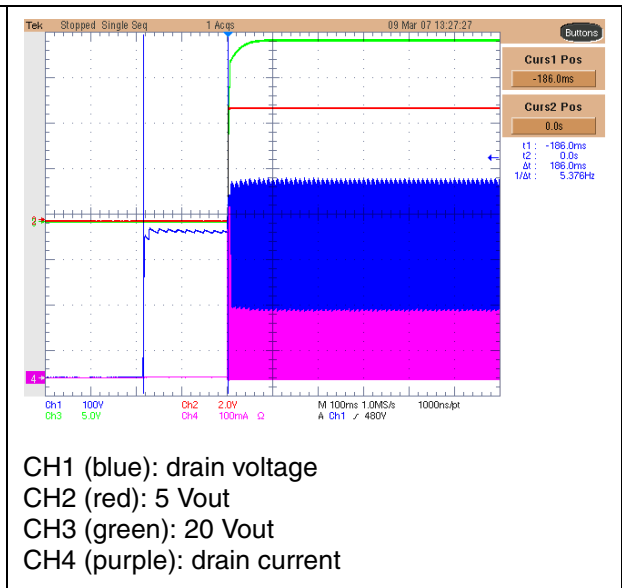

Figure 33. Startup waveforms at minimum load at 110 Vac - 60 Hz

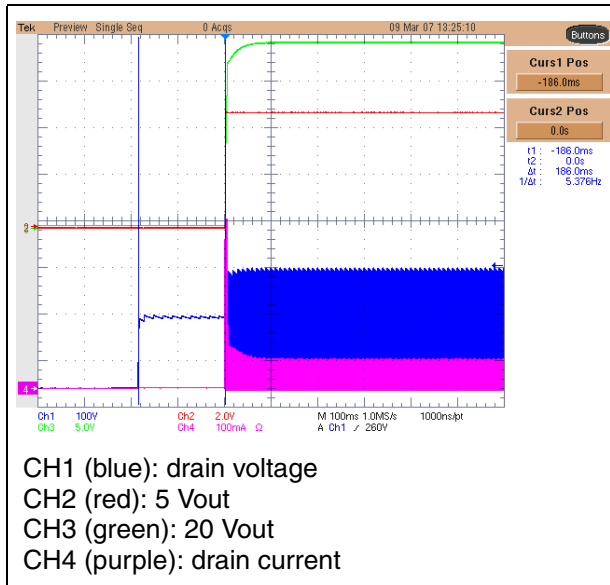
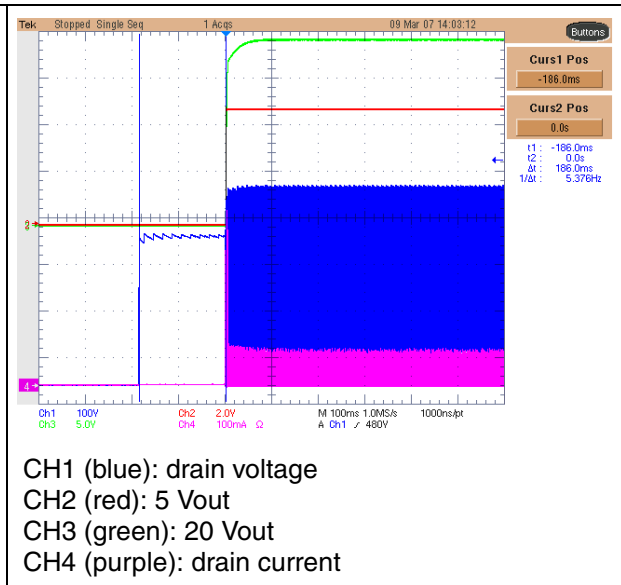

Figure 34. Startup waveforms at minimum load at 230 Vac - 50 Hz



There is no overshoot on the output voltages and the measured wakeup time is 180 mS.

5.3.3 Dynamic load tests

These tests show the transient load response at 110 Vac and 230 Vac mains when the 20 V output current is increased from 10% to 90% of the maximum value.

Figure 35. Dynamic load waveforms at 110 Vac - 60 Hz

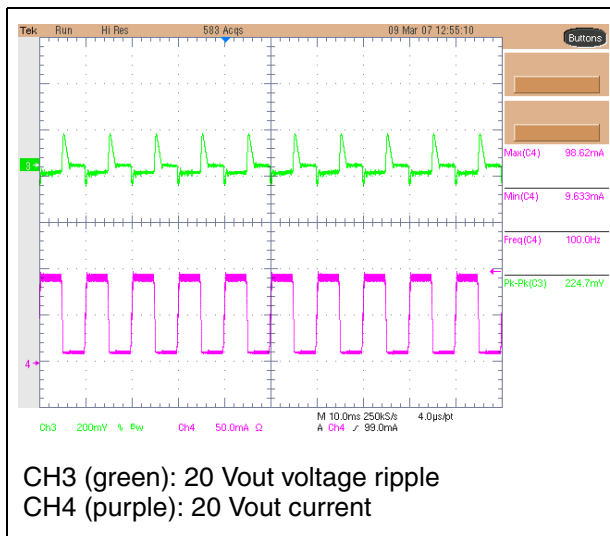
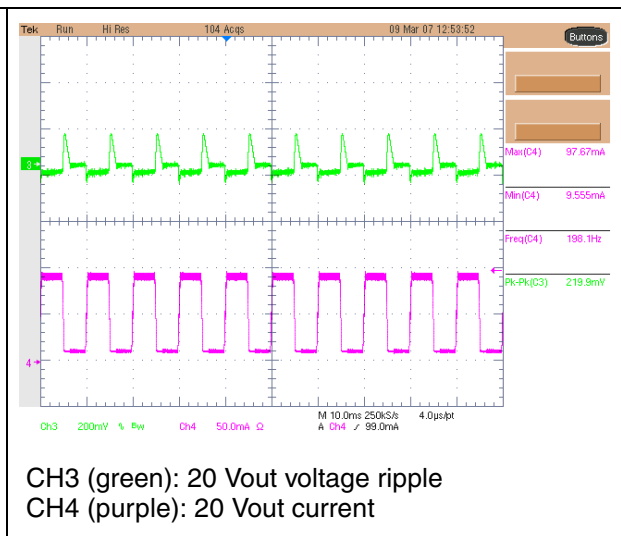

Figure 36. Dynamic load waveforms at 230 Vac - 50 Hz



In the worst case the result is 224 mV or 1.12% of dynamic load regulation which indicates a very good dynamic behavior.

5.3.4 Line regulation

For this test the output power is kept at the peak value (2.2 W) while the line voltage is slowly increased from 85 Vac to 265 Vac. The board has a line regulation of +0.9%.

Figure 37. Line regulation

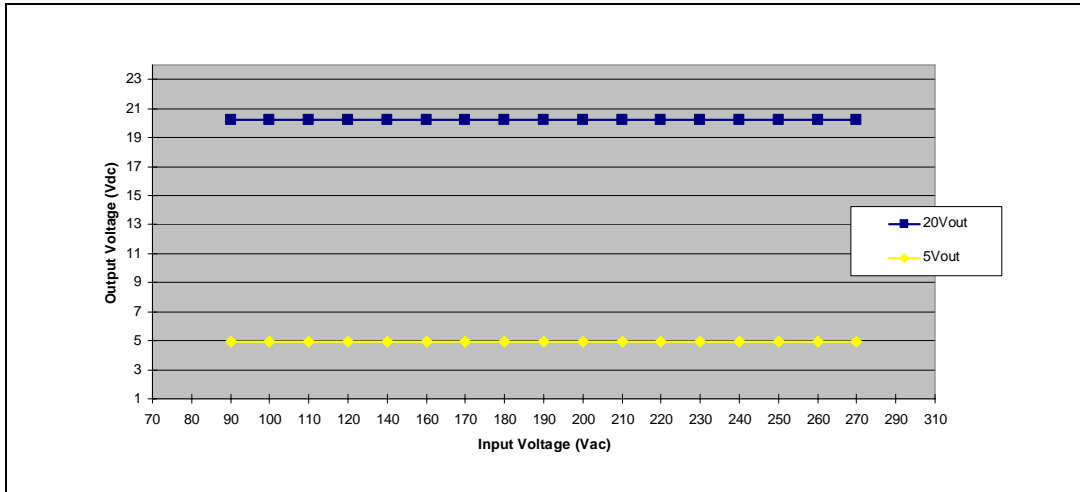

5.3.5 Load regulation

As the 5 V output is obtained by a linear regulator, the load regulation measurements have been performed only on 20 V output by changing its load from 10 mA to full load 100 mA. The input voltage is kept at the nominal value of 230 Vac.

The board has a load regulation of +0.9%.

Figure 38. Load regulation

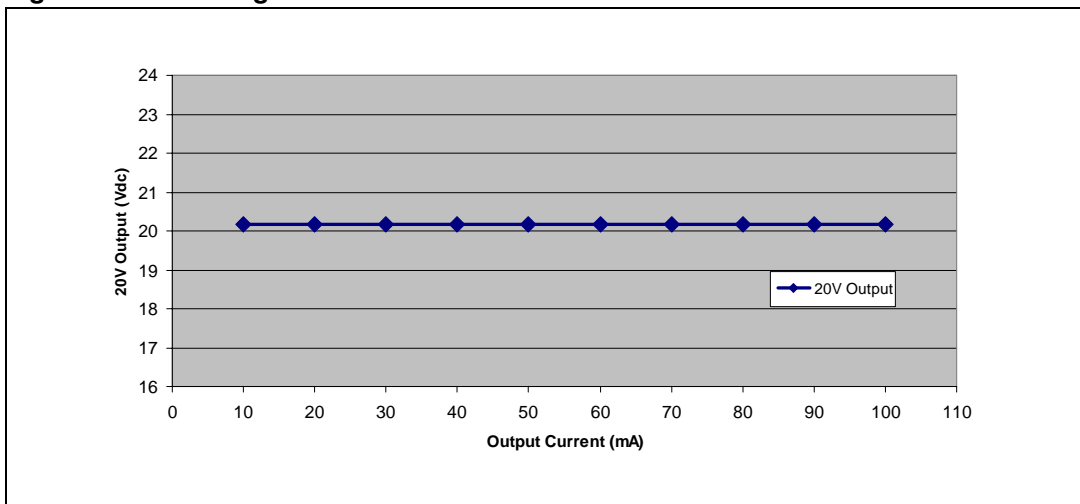

5.3.6 Efficiency variation

For this test the efficiency is measured when the line input is varied from 85 Vac to 264 Vac at full load. The average efficiency is 66.5%. A moderate value is typical of low power applications.

Figure 39. Efficiency variations vs. input voltage at full load

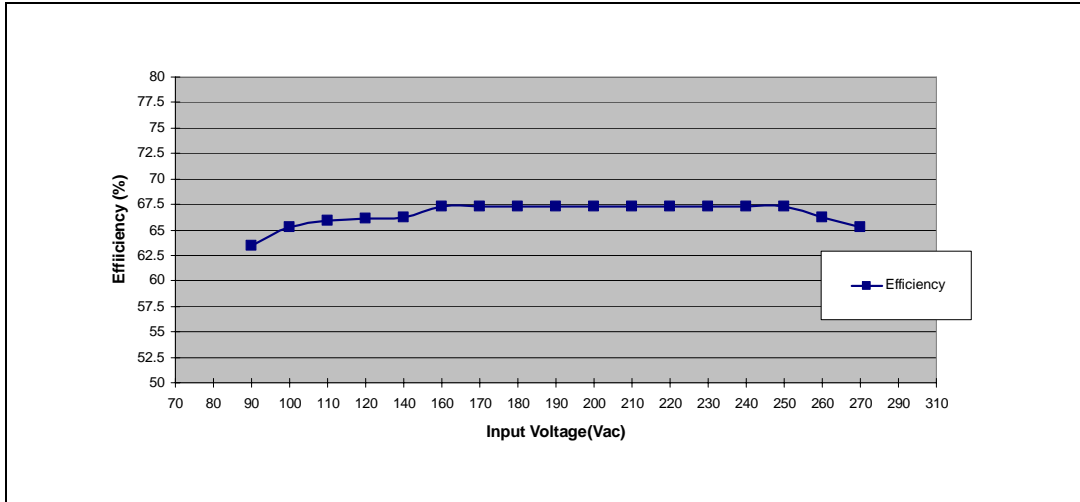

5.3.7 Conducted emissions test

Conducted emissions have been measured in neutral and line wires, using peak detector and considering the limits for lighting applications i.e. EN55015. The measurements have been performed at 110 Vac and 230 Vac line with fully loaded outputs. The results are shown in [Figure 40](#), [41](#), [42](#), and [43](#).

Since the emission level is below both the quasi-peak and average limits with acceptable margin, the power supply passes the pre-compliance test.

Figure 40. Conducted emissions at 110 Vac 60 Hz - full load - line 1 peak detector

Figure 41. Conducted emissions at 110 Vac 60 Hz - full load - line 2 peak detector

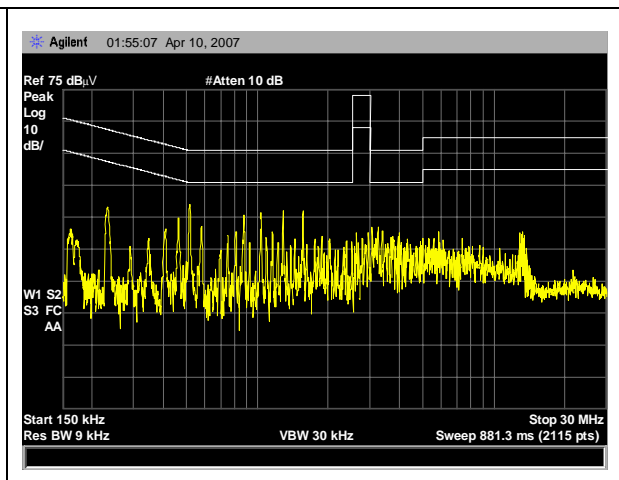
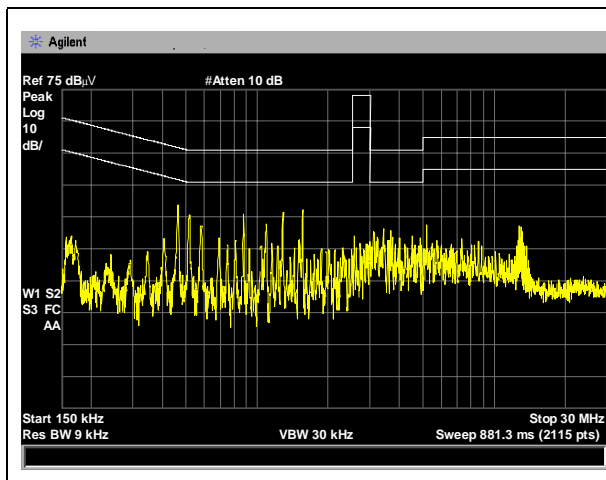

Figure 42. Conducted emissions at 230 Vac 50 Hz - full load - line 1 peak detector

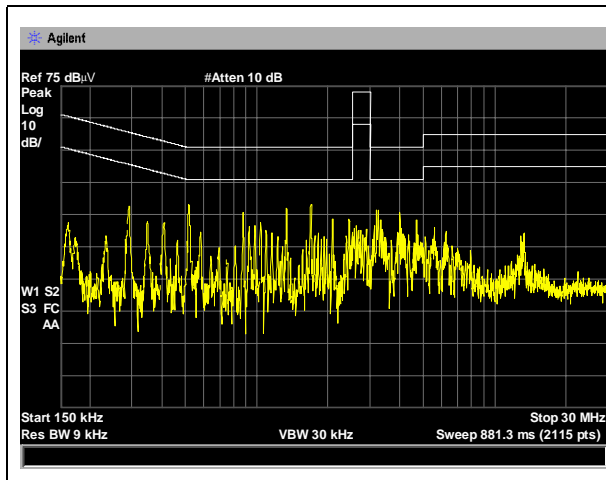
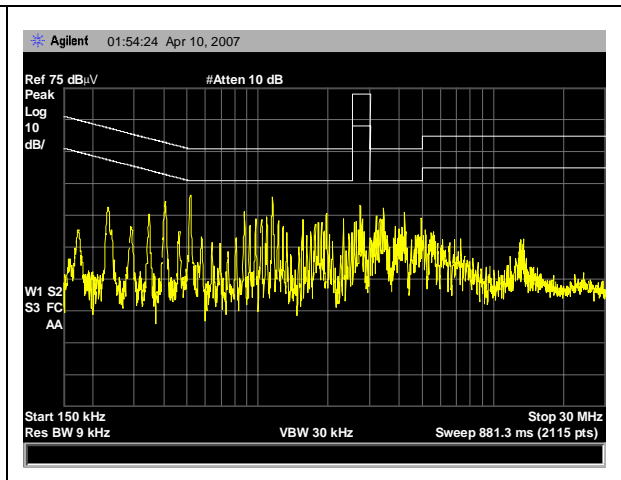

Figure 43. Conducted emissions at 230 Vac 50 Hz - full load - line 2 peak detector



6 References

1. "L6561, enhanced transition mode power factor corrector" (AN966)
2. "Switching from the L6561 to the L6562" (AN1757)
3. "Control loop modelling of L6561-based TM PFC" (AN1089)
4. "Electronic Ballast With Pfc Using L6574 And L6561" (AN993)
5. "Choosing A Dali Implementation Strategy With ST7DALI" (AN1756)
6. "Hardware Implementation for ST7DALI-EVAL" (AN1900)

7 Revision history

Table 13. Document revision history

Date	Revision	Changes
07-Mar-2008	1	Initial release

Please Read Carefully:

Information in this document is provided solely in connection with ST products. STMicroelectronics NV and its subsidiaries ("ST") reserve the right to make changes, corrections, modifications or improvements, to this document, and the products and services described herein at any time, without notice.

All ST products are sold pursuant to ST's terms and conditions of sale.

Purchasers are solely responsible for the choice, selection and use of the ST products and services described herein, and ST assumes no liability whatsoever relating to the choice, selection or use of the ST products and services described herein.

No license, express or implied, by estoppel or otherwise, to any intellectual property rights is granted under this document. If any part of this document refers to any third party products or services it shall not be deemed a license grant by ST for the use of such third party products or services, or any intellectual property contained therein or considered as a warranty covering the use in any manner whatsoever of such third party products or services or any intellectual property contained therein.

UNLESS OTHERWISE SET FORTH IN ST'S TERMS AND CONDITIONS OF SALE ST DISCLAIMS ANY EXPRESS OR IMPLIED WARRANTY WITH RESPECT TO THE USE AND/OR SALE OF ST PRODUCTS INCLUDING WITHOUT LIMITATION IMPLIED WARRANTIES OF MERCHANTABILITY, FITNESS FOR A PARTICULAR PURPOSE (AND THEIR EQUIVALENTS UNDER THE LAWS OF ANY JURISDICTION), OR INFRINGEMENT OF ANY PATENT, COPYRIGHT OR OTHER INTELLECTUAL PROPERTY RIGHT.

UNLESS EXPRESSLY APPROVED IN WRITING BY AN AUTHORIZED ST REPRESENTATIVE, ST PRODUCTS ARE NOT RECOMMENDED, AUTHORIZED OR WARRANTED FOR USE IN MILITARY, AIR CRAFT, SPACE, LIFE SAVING, OR LIFE SUSTAINING APPLICATIONS, NOR IN PRODUCTS OR SYSTEMS WHERE FAILURE OR MALFUNCTION MAY RESULT IN PERSONAL INJURY, DEATH, OR SEVERE PROPERTY OR ENVIRONMENTAL DAMAGE. ST PRODUCTS WHICH ARE NOT SPECIFIED AS "AUTOMOTIVE GRADE" MAY ONLY BE USED IN AUTOMOTIVE APPLICATIONS AT USER'S OWN RISK.

Resale of ST products with provisions different from the statements and/or technical features set forth in this document shall immediately void any warranty granted by ST for the ST product or service described herein and shall not create or extend in any manner whatsoever, any liability of ST.

ST and the ST logo are trademarks or registered trademarks of ST in various countries.

Information in this document supersedes and replaces all information previously supplied.

The ST logo is a registered trademark of STMicroelectronics. All other names are the property of their respective owners.

© 2008 STMicroelectronics - All rights reserved

STMicroelectronics group of companies

Australia - Belgium - Brazil - Canada - China - Czech Republic - Finland - France - Germany - Hong Kong - India - Israel - Italy - Japan - Malaysia - Malta - Morocco - Singapore - Spain - Sweden - Switzerland - United Kingdom - United States of America

www.st.com