

Keysight EEsof EDA

W2302EP/ET Advanced Design System
Transient Convolution Element

W2500EP/ET Transient Convolution
GT Option

W2312EP/ET Transient Convolution
Distributed Computing 8-pack

Introduction

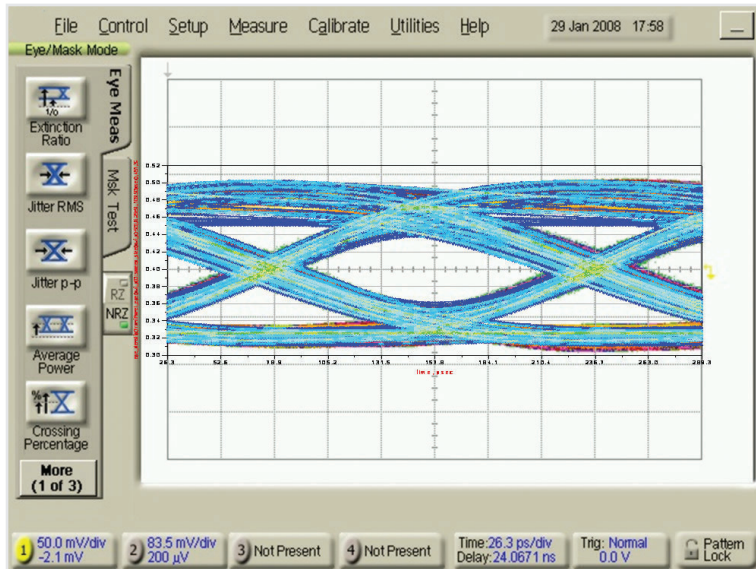

Figure 1. Eye diagram results from the ADS Transient-Convolution Simulator show excellent correlation with measurements, enabling rapid “what if” design space exploration.

The Keysight EEs of EDA—the technology and innovation leader in high-speed, high-frequency electronic design automation—takes SPICE to a new level with the ADS Transient Convolution Element. This simulator is the industry’s fastest signal integrity circuit simulator for multigigabit, high-speed data link design. Multicore processor support and a new, high-capacity sparse matrix solver achieves a three-fold simulation speed improvement for signal integrity simulations.

Design and verification of chip-to-chip multigigabit/s serial links is the most common application for the Transient Convolution Element. At the very high data rates at which these links operate, signal integrity engineers must take into account physical phenomena such as impedance mismatch, reflections, electromagnetic coupling, crosstalk and microwave frequency attenuation due to the skin effect and dielectric loss tangent. The simulator allows signal integrity engineers to perform “what-if” design space exploration using a circuit-level model that can be verified against measured data, and electromagnetic simulation on the post-layout artwork to arrive at an optimum design while avoiding costly and time consuming prototype iterations.

W2302EP/ET Transient Convolution Element

The Transient Convolution Element includes:

- Industry's fastest SPICE simulator.
- A convolution capability that lets you bring components specified by S-parameters in the frequency domain into a time domain simulation. Proven algorithms ensure passivity and causality control. This is especially important for challenging structures such as a long or lossy transmission lines.
- Channel Simulator and Fast Eye Probe features, which allow interactive eye diagram analysis of the transceiver and channel circuitry at million-bit-per-minute simulation rates: about a thousand times faster than conventional SPICE analysis.
- IBIS I/O models, which allow you to incorporate "executable datasheets" from your semiconductor vendors models.
- A Signal integrity verification toolkit, which lets you perform jitter decomposition using the same, tested EZJIT Plus algorithm used in Keysight's test and measurement instruments.
- The Broadband SPICE Model Generator for converting measured or simulated S-parameter models to lumped equivalent or pole-zero representations.

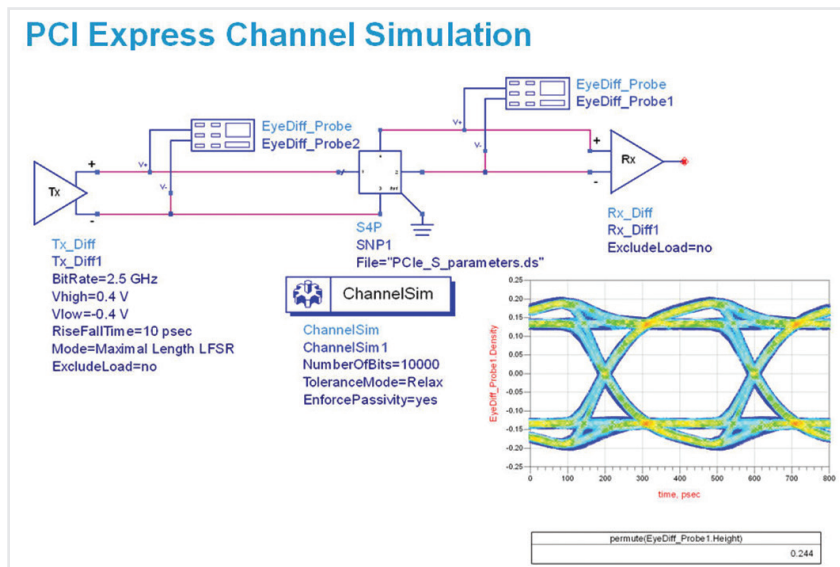

Figure 2. Channel Simulator and Fast Eye Probe provides megabit eye measurements quickly and accurately.

The Transient Convolution Element is unique in that it is not simply a high performance point tool but a set of capabilities integrated into the most complete serial link analysis platform, ADS. With the ADS platform you can move seamlessly between levels of abstraction--system-, circuit-, or physical-level--according to the task at hand.

W2500EP/ET ADS Transient Convolution GT Option

The ADS Transient Convolution GT accelerates signal integrity simulations on workstations that have NVIDIA's Compute Unified Device Architecture (CUDA)-based Graphics Processing Units (GPU). This combination allows signal integrity designers to run these simulations four times faster than on a CPU workstation alone.

W2500EP/ET Transient Convolution GT Element supports NVIDIA Tesla GPU-enabled workstations. For a list of conforming hardware please visit: www.nvidia.com/object/tesla_computing_solutions.html

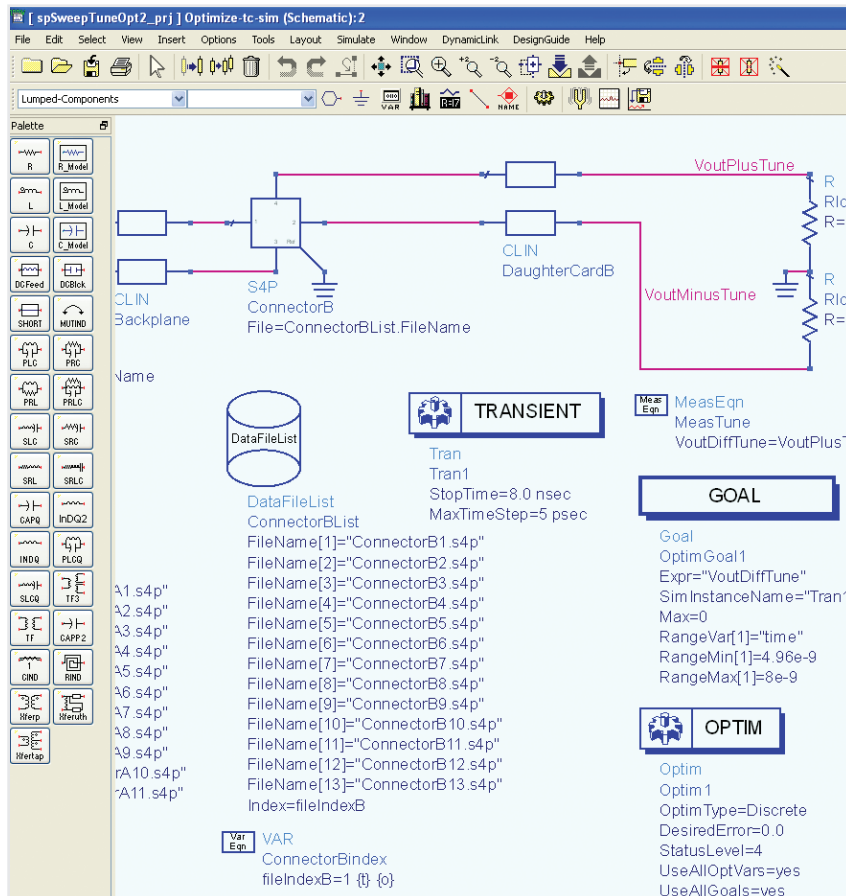

Figure 3. Transient simulation using the DataFileList component lets you quickly and reliably pick the optimum combination of components from your list of candidates.

W2312EP/ET Transient Convolution Distributed Computing 8-pack

The Advanced Design System (ADS) Transient Convolution Distributed Computing 8-pack accelerates signal integrity batch-mode parameter sweeps on workstations connected to a distributed computing cluster. This combination enables signal integrity designers to run these sweeps six to eight times faster than on a single compute node of equal performance. The licenses can be “stacked” in packs of eight, yielding even greater speed up.

This product speeds up parameter sweeps for two combinations:

- Batch Simulation Controller with Transient Simulator, and
- Batch Simulation Controller with Channel Simulator.

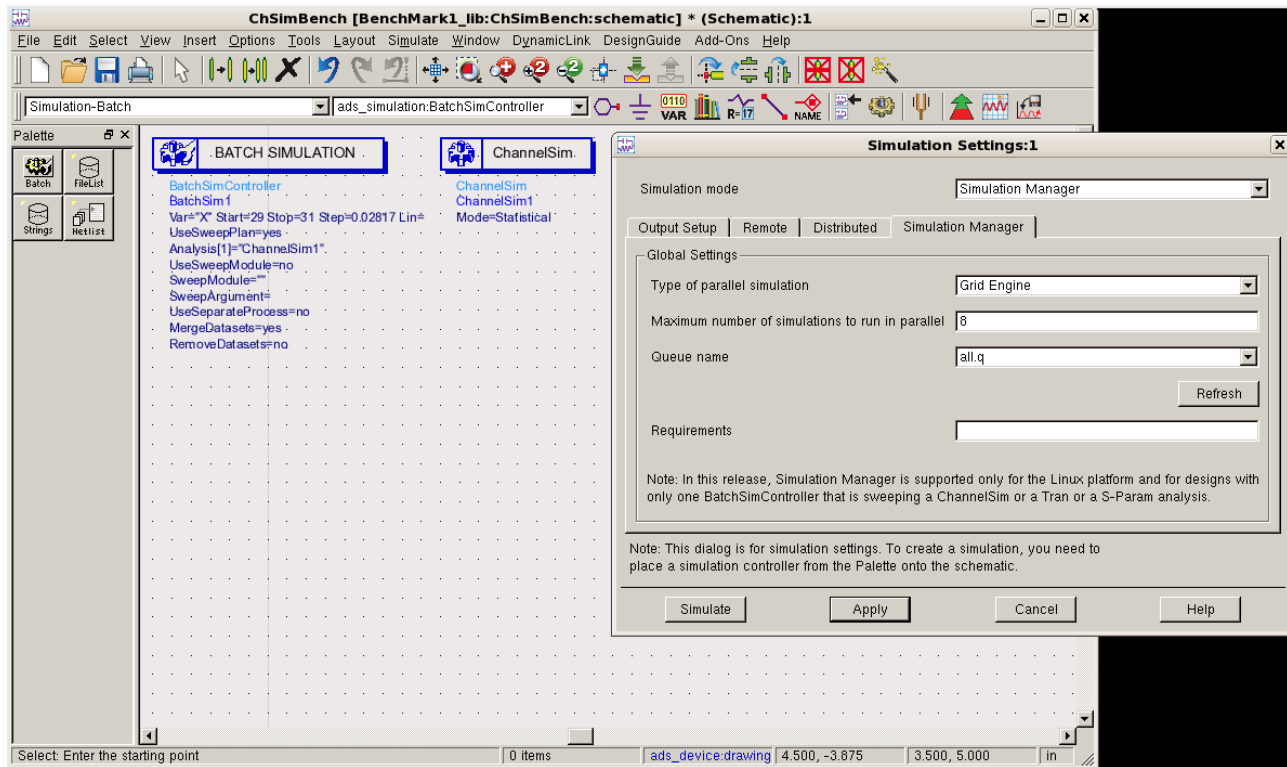

Figure 4. The Transient Convolution Distributed Computing 8-pack is controlled by the Simulation Manager tab of the ADS Simulation Setup menu. This schematic includes parameter sweeps with Batch Simulation Controller with Channel Simulator, but the product also supports Batch Simulation Controller with Transient Simulator (not shown in this figure).

The Transient Convolution Distributed Computing 8-pack presently only supports a configuration where:

- The workstation is running Linux.
- The distributed computing nodes are running Linux with either Load Sharing Facility (LSF) or Sun Grid Engine.

myKeysight

myKeysight

www.keysight.com/find/mykeysight

A personalized view into the information most relevant to you.

Three-Year Warranty

www.keysight.com/find/ThreeYearWarranty

Keysight's commitment to superior product quality and lower total cost of ownership. The only test and measurement company with three-year warranty standard on all instruments, worldwide.



Keysight Assurance Plans

www.keysight.com/find/AssurancePlans

Up to five years of protection and no budgetary surprises to ensure your instruments are operating to specification so you can rely on accurate measurements.



www.keysight.com/go/quality

Keysight Technologies, Inc.
DEKRA Certified ISO 9001:2008
Quality Management System



Keysight Channel Partners

www.keysight.com/find/channelpartners

Get the best of both worlds: Keysight's measurement expertise and product breadth, combined with channel partner convenience.

www.keysight.com/find/eesof

www.keysight.com/find/signal-integrity

For more information on Keysight Technologies' products, applications or services, please contact your local Keysight office. The complete list is available at: www.keysight.com/find/contactus

Americas

Canada	(877) 894 4414
Brazil	55 11 3351 7010
Mexico	001 800 254 2440
United States	(800) 829 4444

Asia Pacific

Australia	1 800 629 485
China	800 810 0189
Hong Kong	800 938 693
India	1 800 112 929
Japan	0120 (421) 345
Korea	080 769 0800
Malaysia	1 800 888 848
Singapore	1 800 375 8100
Taiwan	0800 047 866
Other AP Countries	(65) 6375 8100

Europe & Middle East

Austria	0800 001122
Belgium	0800 58580
Finland	0800 523252
France	0805 980333
Germany	0800 6270999
Ireland	1800 832700
Israel	1 809 343051
Italy	800 599100
Luxembourg	+32 800 58580
Netherlands	0800 0233200
Russia	8800 5009286
Spain	800 000154
Sweden	0200 882255
Switzerland	0800 805353
	Opt. 1 (DE)
	Opt. 2 (FR)
	Opt. 3 (IT)
United Kingdom	0800 0260637

For other unlisted countries:
www.keysight.com/find/contactus
(BP-09-23-14)