

## MILITARY COTS EMI FILTER

<b>-80V to +80V</b> Continuous Input	<b>20A</b> Output Current	<b>32mΩ @ 100°C</b> Max. DC Resistance	<b>&gt;80dB @ 250kHz</b> Differential Attenuation
---	------------------------------	---	--

**FULL POWER OPERATION: -55°C to +100°C**

The Mil-COTS series of EMI filters brings SynQor's field proven technology and manufacturing expertise to the military and aerospace power application marketplace. SynQor's innovative packaging approach ensures survivability in the most hostile environments. Compatible with the industry standard format, these filters have high differential-mode and common-mode attenuation, low DC resistance, and a stabilizing bulk capacitor resistor. They follow conservative component derating guidelines and they are designed and manufactured to the highest standards.

# MilCOTS™



Designed and Manufactured in the USA

### Operational Features

- 20A output current
- Very low DC resistance
- >80 dB differential-mode attenuation at 250kHz
- >36dB common-mode attenuation at 250kHz
- Stabilizing bulk capacitor and damping resistor included
- All capacitors are X7R multi-layer ceramic
- Designed to meet all MIL-STD 461 EMI requirements (D, E, F)

### Mechanical Features

- Size: 2.39" x 1.54" x 0.500"(60.6 x 39.0 x 12.7 mm)
- Total Weight: 3.23 oz. (91.6 g)
- Flanged baseplate version available

### Safety Features

- 2250V input/output to case isolation
- Certified 60950-1 requirement for basic insulation (see Standards and Qualifications page)

### In-Line Manufacturing Process

- AS9100 and ISO 9001 Certified Facility
- Full component traceability

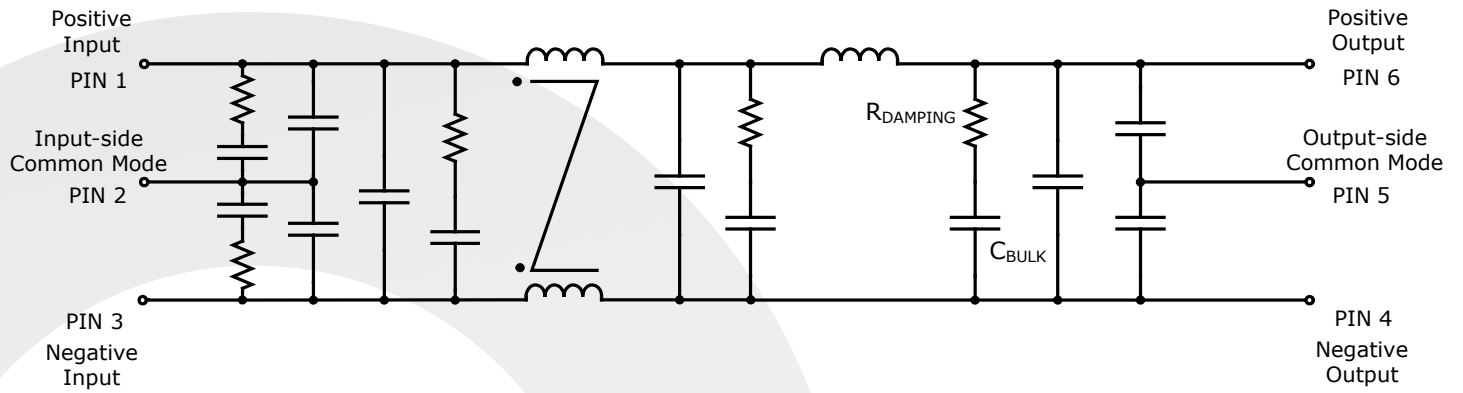
### Screening Qualifications

- Qualified to MIL-STD-810
- Available with S-Grade or M-Grade screening
- Pre-cap inspection per IPC-610, Class III
- Temperature cycling per MIL-STD-883, Method 1010, Condition B, 10 cycles
- Burn-In at 100°C baseplate temperature
- Final visual inspection per MIL-STD-2008

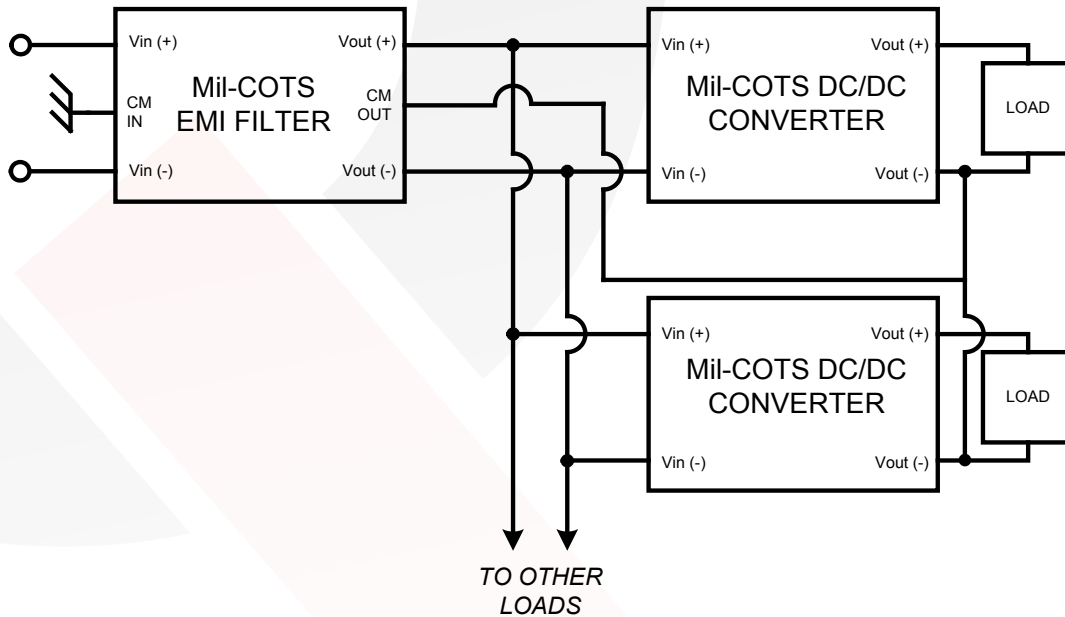


**MCOTS-F-48-P-QT**  
**Current: 20A**

### Fundamental Circuit Diagram



### Typical Connection Diagram





**MCOTS-F-48-P-QT**  
**Current: 20A**

## MCOTS-F-48-P-QT ELECTRICAL CHARACTERISTICS

|Vin| <=48V, |Iout| <= 20A unless otherwise specified.

Specifications subject to change without notice.

Parameter	Min.	Typ.	Max.	Units	Notes & Conditions
<b>ABSOLUTE MAXIMUM RATINGS</b>					
Input Voltage					
Continuous	-80		80	V	
Transient (≤ 1 s)	-100		100	V	
Isolation Voltage	-2250		2250	V	Input/Output to Common-mode pins
Output Current			30	A	
Operating Case Temperature	-55		100	°C	Baseplate Temperature
Storage Case Temperature	-65		135	°C	
<b>RECOMMENDED OPERATION CONDITIONS</b>					
Input Voltage					
Continuous	-80		80	V	
Transient (1 s, Rs* = 0 Ω)	-100		100	V	* Rs = Source Impedance
Output Power (continuous)	-20		20	A	
<b>ELECTRICAL CHARACTERISTICS</b>					
Output Voltage (continuous)	Vout = Vin - (Iin x Rdc)			V	
DC Resistance (Rdc)					Total
Tcase = 25°C			25	mΩ	
Tcase = 100°C			32	mΩ	
Power Dissipation					20A output current
Tcase = 25°C			10	W	
Tcase = 100°C			13	W	
Total Differential-Mode Capacitance		80		μF	Measured across input and output pins
Total Common-Mode Capacitance		0.15		μF	Measured between any pin to case
Bulk Capacitor		60		μF	
Damping Resistor		0.2		Ω	
Noise Attenuation					
Differential-Mode		80		dB	
Common-Mode		36		dB	
Isolation Resistance	100			MΩ	Any pin to common-mode pins
<b>INPUT VOLTAGE SPIKE SUPPRESSION</b>					
Output Voltage Deviation due to a Spike					
Input Voltage Spike (Centered on Vin)					
±250V, 100μs, Emax=15mJ	-5		5	ΔV	MIL-STD-1275D
±600V, 10μs, Rs* = 50Ω	-5		10	ΔV	RTCA/DO-160E
<b>ISOLATION CHARACTERISTICS</b>					
Isolation Voltage (any pin to common-mode pins)					
Continuous	-2000		2000	V	
Transient (≤ 100 μs)	-2250		2250	V	
Isolation Resistance (any pin to common-mode pins)	30			MΩ	
<b>RELIABILITY CHARACTERISTICS</b>					
Calculated MTBF (MIL-STD-217F2)					
GB @ Tcase = 70°C		17.3		10 <sup>6</sup> Hrs.	
GM @ Tcase = 70°C		0.92		10 <sup>6</sup> Hrs.	
Demonstrated MTBF				10 <sup>6</sup> Hrs.	See our website for details
<b>WEIGHT CHARACTERISTICS</b>					
Device Weight		91.6		g	

\* Rs = Source Impedance



### Basic Operation and Features

This module is a multi-stage differential-mode and common-mode passive EMI filter designed to interface a power source with one or more Mil-COTS DC-DC converters (or other loads that create EMI). Each stage of this filter is well damped to avoid resonances and oscillations, and only X7R multi-layer ceramic capacitors are used. This Mil-COTS EMI filter includes a large bulk capacitor with a series damping resistor to correct for the unstabilizing effect of a converter's negative input resistance. A white paper discussing this negative input resistance and the need for corrective damping can be found on the SynQor website (see Input System Instability application note).

When used with SynQor's DC-DC converters, the Mil-COTS EMI filter is designed to pass all of the relevant MIL-STD-461C/D/E requirements to their most stringent limits. The MIL-STD-461 Compliance Matrix Table lists these requirements and describes the setup used to pass them. Figures 3 - 6 show results from selected conductive and radiated emissions tests.

A typical application would place the Mil-COTS filter close to the input of the DC-DC converter. The input-side common-mode pin would be connected to the chassis ground that is common with the system input line filter or other earthed point used for EMI measurement. The output-side common-mode pin would be connected to the output ground or plane of the power converters with as low inductance a path as possible. There are no connections to the metal baseplate, which may also be connected to the chassis ground if desired.

Do not connect the outputs of multiple Mil-COTS filters in parallel. Connecting filters in this manner may result in slightly unequal currents to flow in the positive and return paths of each filter. These unequal currents may cause the internal common-mode chokes to saturate and thus cause degraded common-mode rejection performance.

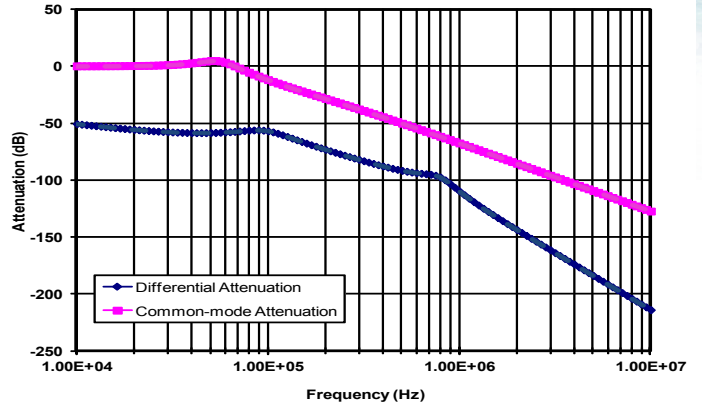


Figure A: Simulation of calculated common mode and differential mode attenuation. The curves plot the ratio of noise current in a 50Ω LISN sensing port connected to the noise output side of the filter (the power input side, pins 1 and 3) to the noise current on the input side (the power output side, pins 4 and 6). Refer to Figures B and C.

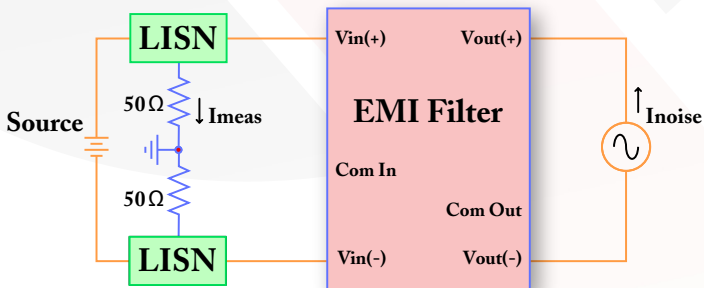


Figure B: Differential-Mode Current Attenuation,  $I_{meas} / I_{noise}$

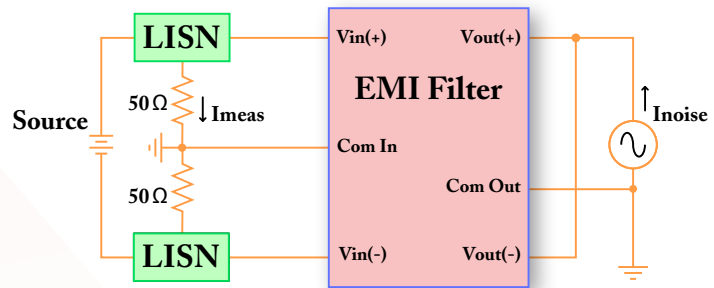
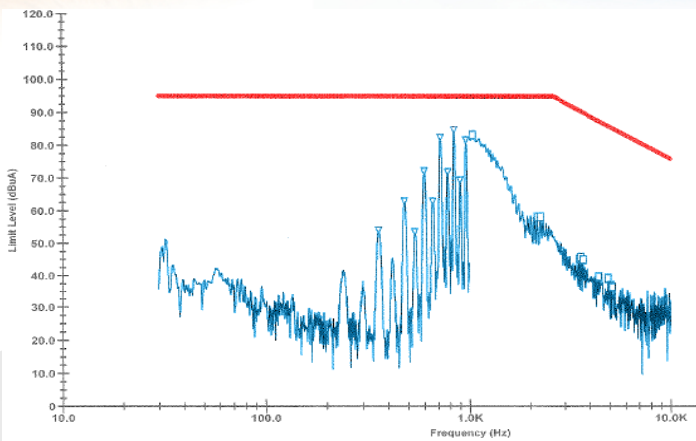


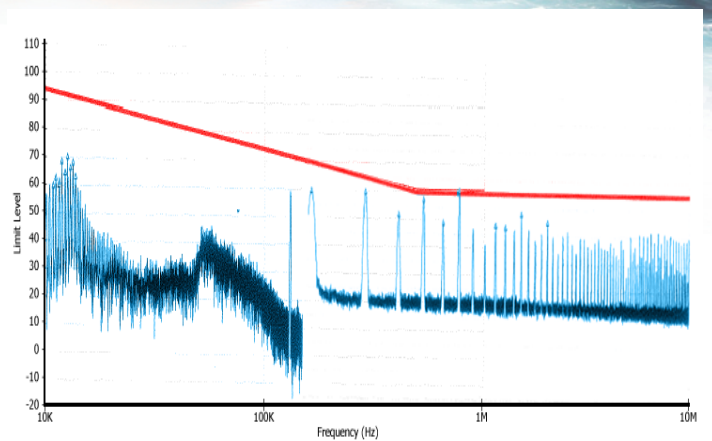
Figure C: Common-Mode Current Attenuation,  $I_{meas} / I_{noise}$



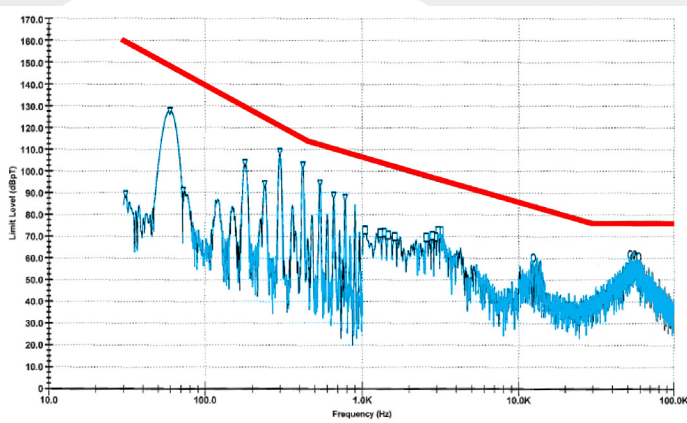
**MCOTS-F-48-P-QT**  
**Current: 20A**



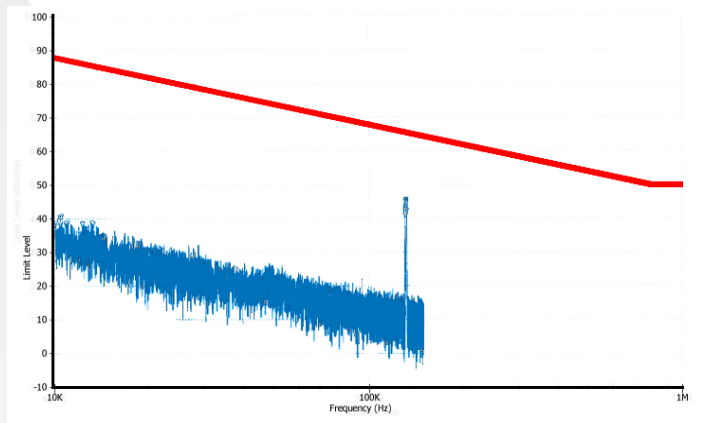
**Figure 1:** MIL-STD-461E Method CE101 Low Frequency Conducted Emissions. Limit line (in red) is the 'Submarine Applications DC Curve'.



**Figure 2:** MIL-STD-461E Method CE102 High Frequency Conducted Emissions. Limit line (in red) is the 'Basic Curve'.

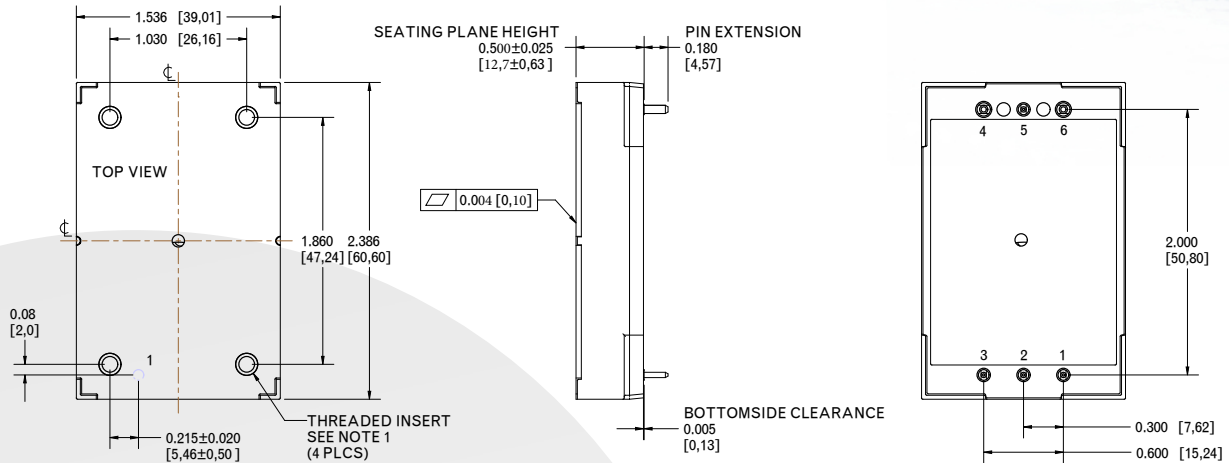


**Figure 3:** MIL-STD-461E Method RE101 Low Frequency Radiated Emissions. Limit line (in red) is the 'Standard Curve'.



**Figure 4:** MIL-STD-461E Method RE102 High Frequency Radiated Emissions. Limit line (in red) is the 'Submarine Internal to Pressure Hull Curve'.

## Encased Mechanical Diagram



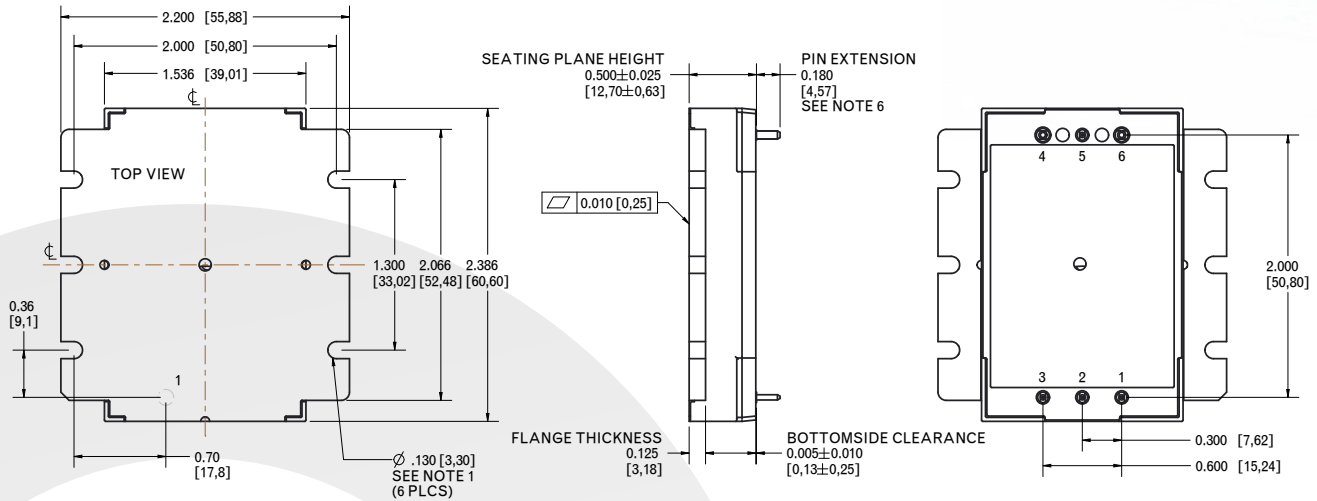
## NOTES

- 1) M3 SCREWS USED TO BOLT UNIT'S BASEPLATE TO OTHER SURFACES SUCH AS HEATSINK MUST NOT EXCEED 0.100" (2.54mm) DEPTH BELOW THE SURFACE OF THE BASEPLATE.
- 2) APPLIED TORQUE PER SCREW SHOULD NOT EXCEED 6in-lb (0.7Nm).
- 3) BASEPLATE FLATNESS TOLERANCE IS 0.004" (.10mm) TIR FOR SURFACE.
- 4) PINS 1-3 & 5 ARE 0.040" (1.02mm) DIA. WITH 0.080" (2.03mm) DIA. STANDOFF SHOULDERS
- 5) PINS 4 & 6 ARE 0.062" (1.57mm) DIA. WITH 0.100" (2.54mm) DIA STANDOFF SHOULDERS.
- 6) ALL PINS: MATERIAL: COPPER ALLOY  
FINISH: MATTE TIN OVER NICKEL PLATE
- 7) UNDIMENSIONED COMPONENTS ARE SHOWN FOR VISUAL REFERENCE ONLY
- 8) WEIGHT 3.23oz. (91.6g)
- 9) ALL DIMENSIONS IN INCHES(mm)  
TOLERANCES: X.XXIN +/-0.02 (X.Xmm +/-0.5mm)  
X.XXXIN +/-0.010 (X.XXmm +/-0.25mm)

## PIN DESIGNATIONS

Pin	Name	Function
1	Vin (+)	Positive input voltage
2	COM IN	Input-side common-mode
3	Vin (-)	Negative input voltage
4	Vout (-)	Negative output voltage
5	COM OUT	Output-side common-mode
6	Vout (+)	Positive output voltage

## Flanged Encased Mechanical Diagram



## NOTES

- 1) APPLIED TORQUE PER SCREW SHOULD NOT EXCEED 5in-lb
- 2) BASEPLATE FLATNESS TOLERANCE IS 0.01" (.2mm) TIR FOR SURFACE.
- 3) PINS 1-3 & 5 ARE 0.040" (1.02mm) DIA. WITH 0.080" (2.03mm) DIA. STANDOFF SHOULDERS
- 4) PINS 4 & 6 ARE 0.062" (1.57mm) DIA. WITH 0.100" (2.54mm) DIA STANDOFF SHOULDERS.
- 5) ALL PINS: MATERIAL: COPPER ALLOY  
FINISH: MATTE TIN OVER NICKEL PLATE
- 6) UNDIMENSIONED COMPONENTS ARE SHOWN FOR VISUAL REFERENCE ONLY
- 7) WEIGHT 3.49oz. (98.9g)
- 8) ALL DIMENSIONS IN INCHES(mm)  
TOLERANCES: X.XXIN +/-0.02 (X.Xmm +/-0.5mm)  
X.XXXIN +/-0.010 (X.XXmm +/-0.25mm)

## PIN DESIGNATIONS

Pin	Name	Function
1	Vin (+)	Positive input voltage
2	COM IN	Input-side common-mode
3	Vin (-)	Negative input voltage
4	Vout (-)	Negative output voltage
5	COM OUT	Output-side common-mode
6	Vout (+)	Positive output voltage





**MCOTS-F-48-P-QT**  
**Current: 20A**

**Mil-COTS MIL-STD-810G Qualification Testing**

MIL-STD-810G Test	Method	Description
<b>Fungus</b>	508.6	Table 508.6-I
<b>Altitude</b>	500.5 - Procedure I	Storage: 70,000 ft / 2 hr duration
	500.5 - Procedure II	Operating: 70,000 ft / 2 hr duration; Ambient Temperature
<b>Rapid Decompression</b>	500.5 - Procedure III	Storage: 8,000 ft to 40,000 ft
<b>Acceleration</b>	513.6 - Procedure II	Operating: 15 g
<b>Salt Fog</b>	509.5	Storage
<b>High Temperature</b>	501.5 - Procedure I	Storage: 135 °C / 3 hrs
	501.5 - Procedure II	Operating: 100 °C / 3 hrs
<b>Low Temperature</b>	502.5 - Procedure I	Storage: -65 °C / 4 hrs
	502.5 - Procedure II	Operating: -55 °C / 3 hrs
<b>Temperature Shock</b>	503.5 - Procedure I - C	Storage: -65 °C to 135 °C; 12 cycles
<b>Rain</b>	506.5 - Procedure I	Wind Blown Rain
<b>Immersion</b>	512.5 - Procedure I	Non-Operating
<b>Humidity</b>	507.5 - Procedure II	Aggravated cycle @ 95% RH (Figure 507.5-7 aggravated temp - humidity cycle, 15 cycles)
<b>Random Vibration</b>	514.6 - Procedure I	10 - 2000 Hz, PSD level of 1.5 g <sup>2</sup> /Hz (54.6 g <sub>rms</sub> ), duration = 1 hr/axis
<b>Shock</b>	516.6 - Procedure I	20 g peak, 11 ms, Functional Shock (Operating no load) (saw tooth)
	516.6 - Procedure VI	Bench Handling Shock
<b>Sinusoidal vibration</b>	514.6 - Category 14	Rotary wing aircraft - helicopter, 4 hrs/axis, 20 g (sine sweep from 10 - 500 Hz)
<b>Sand and Dust</b>	510.5 - Procedure I	Blowing Dust
	510.5 - Procedure II	Blowing Sand

**EMI**

**Military Standard 461 Compliance Matrix**

This table shows the MIL-STD-461 requirements/limits that will be met\* by the stand-alone setups indicated below:

Mil-Std-461	MIL-STD-461D/E/F	
	Requirement	Most Stringent Limit Listed
<b>Conducted Emissions</b>	CE101 CE102	Submarine Basic Curve
<b>Conducted Susceptibility</b>	CS101 CS106 CS114 CS115 CS116	Curve #2 461F Only Curve #5 Basic Waveform I <sub>max</sub> = 10A
<b>Radiated Emissions</b>	RE101	Navy
	RE102†	Submarine Fixed Wing Internal, >25 meters Nose to Tail
<b>Radiated Susceptibility</b>	RS101 RS103	Army Aircraft External

\* Susceptibility requirements/limits are considered to be met as long as transient deviations in the converter's output voltage remain within ±10% of its initial value.

† Met with metal screen shield covering the filter, converter, and resistive load.

‡ In almost every case the limit listed is the most stringent of the requirements. The one exception is CE03 - High Frequency Broadband Conducted Emissions, Converter with Passive Filter. In this case the filter and converter passed the A1 limit. The filter and converter pass the CE03 - Narrowband Conducted Emissions at the A5 limit level.

<b>MCOTS</b>	<ul style="list-style-type: none"> <li>• MCOTS-F-28-P Filter</li> <li>• MCOTS-28-05S Converter</li> <li>• 120W Resistive load</li> <li>• Metal Chassis Plane</li> <li>• MCOTS-F-270-P Filter</li> <li>• MCOTS-270-05-QT Converter</li> </ul>
--------------	--



## Ordering Information

Example MCOTS-F-48-P-QT-N-S

Family	Product	Input Voltage	Filter Type	Package	Thermal Design	Screening Level
MCOTS	F: Filter	<b>28:</b> -40V to +40V <b>48:</b> -80V to +80V <b>270:</b> -500V to +500V	<b>P:</b> Passive <b>T:</b> Transient	<b>QT:</b> Quarter Brick <b>HT:</b> Half Brick	<b>N:</b> Normal Threaded <b>F:</b> Flanged	<b>S:</b> S-Grade <b>M:</b> M-Grade

Not all combinations make valid part numbers, please contact SynQor for availability. See the Product Summary web page for more options.

### Application Notes

A variety of application notes and technical white papers can be downloaded in pdf format from our website.

### Contact SynQor for further information and to order:

**Phone:** 978-849-0600  
**Toll Free:** 888-567-9596  
**Fax:** 978-849-0602  
**E-mail:** [power@synqor.com](mailto:power@synqor.com)  
**Web:** [www.synqor.com](http://www.synqor.com)  
**Address:** 155 Swanson Road  
 Boxborough, MA 01719  
 USA

### PATENTS

SynQor holds numerous U.S. patents, one or more of which apply to most of its power conversion products. Any that apply to the product(s) listed in this document are identified by markings on the product(s) or on internal components of the product(s) in accordance with U.S. patent laws. SynQor's patents include the following:

5,999,417	6,222,742	6,545,890	6,594,159	6,894,468	6,896,526
6,927,987	7,050,309	7,072,190	7,085,146	7,119,524	7,269,034
7,272,021	7,272,023	7,558,083	7,564,702	7,765,687	7,787,261
8,023,290	8,149,597	8,493,751	8,644,027	9,143,042	

### Warranty

SynQor offers a two (2) year limited warranty. Complete warranty information is listed on our website or is available upon request from SynQor.