



13003BS

Preliminary

NPN SILICON TRANSISTOR

NPN SILICON BIPOLAR TRANSISTORS FOR LOW FREQUENCY AMPLIFICATION

DESCRIPTION

The UTC **13003BS** is a silicon NPN power switching transistor; it uses UTC's advanced technology to provide customers high collector-base breakdown voltage, low reverse leakage current and high reliability, etc.

The UTC **13003BS** is suitable for electronic ballast power switch circuit and the compact electronic energy-saving light.

FEATURES

- * High collector-base breakdown voltage
- * Low reverse leakage current
- * High reliability

EQUIVALENT CIRCUIT

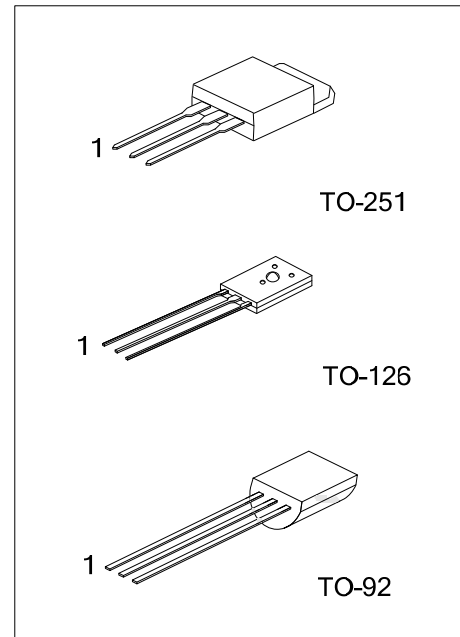
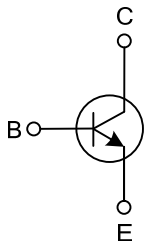

ORDERING INFORMATION

Ordering Number		Package	Pin Assignment			Packing
Lead Free	Halogen Free		1	2	3	
13003BSL-TM3-T	13003BSG-TM3-T	TO-251	B	C	E	Tube
13003BSL-T60-F-K	13003BSG-T60-F-K	TO-126	B	C	E	Bulk
13003BSL-T92-F-B	13003BSG-T92-F-B	TO-92	B	C	E	Tape Box
13003BSL-T92-F-K	13003BSG-T92-F-K	TO-92	B	C	E	Bulk

Note: Pin Assignment: B: Base C: Collector E: Emitter

<p>13003BSL-T60-F-B</p> <ul style="list-style-type: none"> (1) Packing Type (2) Pin Assignment (3) Package Type (4) Lead Free 	<ul style="list-style-type: none"> (1) T: Tube, B: Bulk, K: Bulk (2) refer to Pin Assignment (3) TM3: TO-251, T60: TO-126, T92: TO-92 (4) L: Lead Free, G: Halogen Free
---	---

■ MARKING

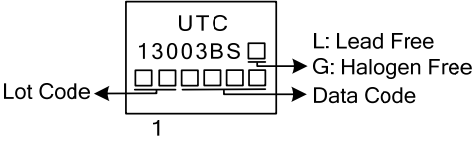
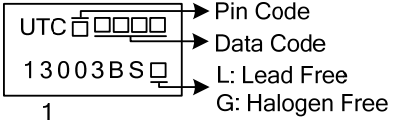
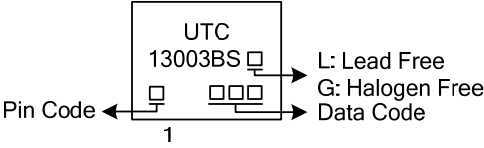
PACKAGE	MARKING
TO-251	 <p>Diagram showing marking on a TO-251 package. The marking includes 'UTC' and '13003BS' followed by a pin code '1'. A 'Lot Code' is indicated by four small squares. To the right, 'L: Lead Free', 'G: Halogen Free', and 'Data Code' are listed with arrows pointing to the corresponding marking elements.</p>
TO-126	 <p>Diagram showing marking on a TO-126 package. The marking includes 'UTC', a pin code '1', '13003BS', and another pin code '1'. To the right, 'Pin Code', 'Data Code', 'L: Lead Free', and 'G: Halogen Free' are listed with arrows pointing to the corresponding marking elements.</p>
TO-92	 <p>Diagram showing marking on a TO-92 package. The marking includes 'UTC', '13003BS', a pin code '1', and a 'Data Code'. To the right, 'L: Lead Free', 'G: Halogen Free', and 'Data Code' are listed with arrows pointing to the corresponding marking elements.</p>

■ ABSOLUTE MAXIMUM RATINGS ($T_A=25^\circ\text{C}$, unless otherwise noted)

PARAMETER		SYMBOL	RATINGS	UNIT
Collector-Base Voltage		V_{CBO}	800	V
Collector-Emitter Voltage		V_{CEO}	450	V
Emitter-Base Voltage		V_{EBO}	9	V
Collector Current	Continuous	I_C	2	A
	Peak	I_{CM}	4	A
Base Current	Continuous	I_B	1	A
	Peak	I_{BM}	2	A
Power Dissipation ($T_C=25^\circ\text{C}$)	TO-251	P_D	10	W
	TO-126		20	W
	TO-92		1	W
Junction Temperature		T_J	150	$^\circ\text{C}$
Storage Temperature Range		T_{STG}	-55~+150	$^\circ\text{C}$

Note: Absolute maximum ratings are those values beyond which the device could be permanently damaged.

Absolute maximum ratings are stress ratings only and functional device operation is not implied.

■ THERMAL DATA

PARAMETER		SYMBOL	RATING	UNIT
Junction to Ambient	TO-251	θ_{JA}	90	$^\circ\text{C/W}$
	TO-126		100	
	TO-92		150	
Junction to Case	TO-251	θ_{JC}	12.5	$^\circ\text{C/W}$
	TO-126		7.5	
	TO-92		100	

■ ELECTRICAL CHARACTERISTICS ($T_A=25^\circ\text{C}$, unless otherwise noted)

PARAMETER	SYMBOL	TEST CONDITIONS	MIN	TYP	MAX	UNIT
Collector-Base Breakdown Voltage	BV_{CBO}	$I_C=1\text{mA}$, $I_E=0$	800			V
Collector-Emitter Breakdown Voltage	BV_{CEO}	$I_C=1\text{mA}$, $I_B=0$	450			V
Emitter-Base Breakdown Voltage	BV_{EBO}	$I_E=1\text{mA}$, $I_C=0$	9			V
Collector Cut-Off Current	I_{CBO}	$V_{CB}=800\text{V}$, $I_E=0$			0.1	mA
Collector-Emitter Cut-Off Current	I_{CEO}	$V_{CE}=450\text{V}$, $I_B=0$			0.1	mA
Emitter-Base Cut-Off Current	I_{EBO}	$V_{EB}=9\text{V}$, $I_C=0$			0.1	mA
DC Current Gain (Note)	h_{FE}	$V_{CE}=5\text{V}$, $I_C=0.2\text{A}$	20		35	
Low current and high current h_{FE2} h_{FE1} ratio	h_{FE1}/h_{FE2}	h_{FE1} : $V_{CE}=5\text{V}$, $I_C=5\text{mA}$	0.75			
		h_{FE2} : $V_{CE}=5\text{V}$, $I_C=0.2\text{A}$				
Collector-Emitter Saturation Voltage (Note)	$V_{CE(SAT)}$	$I_C=0.5\text{A}$, $I_B=0.1\text{A}$			0.8	V
Base-Emitter Saturation Voltage (Note)	$V_{BE(SAT)}$	$I_C=0.5\text{A}$, $I_B=0.1\text{A}$			1.5	V
Storage Time	t_S	UI9600, $I_C=0.25\text{A}$	2		5	μs
Rise Time	t_R				2	μs
Fall Time	t_F				2	μs
Transition Frequency	f_T	$V_{CE}=10\text{V}$, $I_C=0.1\text{A}$, $f=1\text{MHz}$	5			MHz

Note: Pulse test, pulse width $t_p \leq 300\mu\text{s}$, Duty cycle $\leq 2\%$.

UTC assumes no responsibility for equipment failures that result from using products at values that exceed, even momentarily, rated values (such as maximum ratings, operating condition ranges, or other parameters) listed in products specifications of any and all UTC products described or contained herein. UTC products are not designed for use in life support appliances, devices or systems where malfunction of these products can be reasonably expected to result in personal injury. Reproduction in whole or in part is prohibited without the prior written consent of the copyright owner. The information presented in this document does not form part of any quotation or contract, is believed to be accurate and reliable and may be changed without notice.