

VOLTAGE RANGE: 6.8 - 440V
POWER: 600Watts

Features

- Glass Passivated Die Construction
- Uni- and Bi-Directional Versions Available
- Excellent Clamping Capability
- Fast Response Time
- Plastic Material: UL Flammability Classification Rating 94V-0

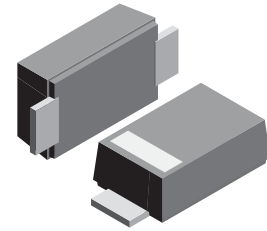

Mechanical Data

- Case: SMBF, Molded Plastic
- Terminals: Solder Plated, Solderable per MIL-STD-750, Method 2026
- Polarity: Cathode Band or Cathode Notch
- Marking: Type Number
- Weight: 0.0018 ounces, 0.05grams

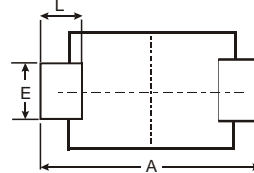
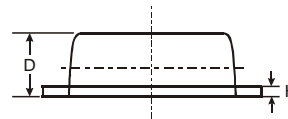
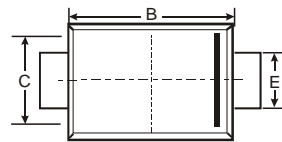

SMBF			
Dim	Min	Max	Typ
A	5.45	5.55	5.50
B	4.27	4.33	4.30
C	3.57	3.63	3.60
D	1.32	1.38	1.35
E	1.96	2.00	1.98
H	0.019	0.021	0.20
L	0.73	0.77	0.75
All Dimensions in mm			



Maximum Ratings @ $T_A = 25^\circ\text{C}$ unless otherwise specified

Characteristic	Symbol	Value	Unit
Peak Pulse Power Dissipation (Non repetitive current pulse derated above $T_A = 25^\circ\text{C}$) (Note 1)	P_{PK}	600	W
Peak Forward Surge Current, 8.3ms Single Half Sine Wave Superimposed on Rated Load (JEDEC Method) (Notes 1, 2, & 3)	I_{FSM}	100	A
Instantaneous Forward Voltage @ $I_{PP} = 35\text{A}$ (Notes 1, 2, & 3)	V_F	$V_{BR} < 100\text{V}$: 3.5 $V_{BR} \geq 100\text{V}$: 5.0	V V
Operating and Storage Temperature Range	T_j, T_{STG}	-55 to +150	$^\circ\text{C}$

- Notes:
1. Valid provided that terminals are kept at ambient temperature.
 2. Measured with 8.3ms single half sine-wave. Duty cycle = 4 pulses per minute maximum.
 3. Unidirectional units only.



TYPE		Reverse Stand-Off Voltage	Breakdown Voltage Min. @I _T	Breakdown Voltage Max. @ I _T	Test Current	Maximum Clamping Voltage @I _{PP}	Peak Pulse Current	Reverse Leakage @V _{RWM}
(Uni)	(Bi)	V _{RWM} (V)	V _{BR MIN} (V)	V _{BR MAX} (V)	I _T (mA)	V _C (V)	I _{PP} (A)	I _R (uA)
P6SMBFJ6.8	P6SMBFJ6.8C	5.50	6.12	7.48	10.0	10.8	55.6	1000.0
P6SMBFJ6.8A	P6SMBFJ6.8CA	5.80	6.45	7.14	10.0	10.5	57.1	1000.0
P6SMBFJ7.5	P6SMBFJ7.5C	6.05	6.75	8.25	10.0	11.7	51.3	500.0
P6SMBFJ7.5A	P6SMBFJ7.5CA	6.40	7.13	7.88	10.0	11.3	53.1	500.0
P6SMBFJ8.2	P6SMBFJ8.2C	6.63	7.38	9.02	10.0	12.5	48.0	200.0
P6SMBFJ8.2A	P6SMBFJ8.2CA	7.02	7.79	8.61	10.0	12.1	49.6	200.0
P6SMBFJ9.1	P6SMBFJ9.1C	7.37	8.19	10.0	1.0	13.8	43.5	50.0
P6SMBFJ9.1A	P6SMBFJ9.1CA	7.78	8.65	9.55	1.0	13.4	44.8	50.0
P6SMBFJ10	P6SMBFJ10C	8.10	9.00	11.0	1.0	15.0	40.0	10.0
P6SMBFJ10A	P6SMBFJ10CA	8.55	9.50	10.5	1.0	14.5	41.4	10.0
P6SMBFJ11	P6SMBFJ11C	8.92	9.90	12.1	1.0	16.2	37.0	5.0
P6SMBFJ11A	P6SMBFJ11CA	9.40	10.5	11.6	1.0	15.6	38.5	5.0
P6SMBFJ12	P6SMBFJ12C	9.72	10.8	13.2	1.0	17.3	34.7	5.0
P6SMBFJ12A	P6SMBFJ12CA	10.2	11.4	12.6	1.0	16.7	35.9	5.0
P6SMBFJ13	P6SMBFJ13C	10.5	11.7	14.3	1.0	19.0	31.6	5.0
P6SMBFJ13A	P6SMBFJ13CA	11.1	12.4	13.7	1.0	18.2	33.0	5.0
P6SMBFJ15	P6SMBFJ15C	12.1	13.5	16.5	1.0	22.0	27.3	5.0
P6SMBFJ15A	P6SMBFJ15CA	12.8	14.3	15.8	1.0	21.2	28.3	5.0
P6SMBFJ16	P6SMBFJ16C	12.9	14.4	17.6	1.0	23.5	25.5	5.0
P6SMBFJ16A	P6SMBFJ16CA	13.6	15.2	16.8	1.0	22.5	26.7	5.0
P6SMBFJ18	P6SMBFJ18C	14.5	16.2	19.8	1.0	26.5	22.6	5.0
P6SMBFJ18A	P6SMBFJ18CA	15.3	17.1	18.9	1.0	25.2	23.8	5.0
P6SMBFJ20	P6SMBFJ20C	16.2	18.0	22.0	1.0	29.1	20.6	5.0
P6SMBFJ20A	P6SMBFJ20CA	17.1	19.0	21.0	1.0	27.7	21.7	5.0
P6SMBFJ22	P6SMBFJ22C	17.8	19.8	24.2	1.0	31.9	18.8	5.0
P6SMBFJ22A	P6SMBFJ22CA	18.8	20.9	23.1	1.0	30.6	19.6	5.0
P6SMBFJ24	P6SMBFJ24C	19.4	21.6	26.4	1.0	34.7	17.3	5.0
P6SMBFJ24A	P6SMBFJ24CA	20.5	22.8	25.2	1.0	33.2	18.1	5.0
P6SMBFJ27	P6SMBFJ27C	21.8	24.3	29.7	1.0	39.1	15.3	5.0
P6SMBFJ27A	P6SMBFJ27CA	23.1	25.7	28.4	1.0	37.5	16.0	5.0
P6SMBFJ30	P6SMBFJ30C	24.3	27.0	33.0	1.0	43.5	13.8	5.0
P6SMBFJ30A	P6SMBFJ30CA	25.6	28.5	31.5	1.0	41.4	14.5	5.0
P6SMBFJ33	P6SMBFJ33C	26.8	29.7	36.3	1.0	47.7	12.6	5.0
P6SMBFJ33A	P6SMBFJ33CA	28.2	31.4	34.7	1.0	45.7	13.1	5.0
P6SMBFJ36	P6SMBFJ36C	29.1	32.4	39.6	1.0	52.0	11.5	5.0
P6SMBFJ36A	P6SMBFJ36CA	30.8	34.2	37.8	1.0	49.9	12.0	5.0
P6SMBFJ39	P6SMBFJ39C	31.6	35.1	42.9	1.0	56.4	10.6	5.0
P6SMBFJ39A	P6SMBFJ39CA	33.3	37.1	41.0	1.0	53.9	11.1	5.0
P6SMBFJ43	P6SMBFJ43C	34.8	38.7	47.3	1.0	61.9	9.7	5.0
P6SMBFJ43A	P6SMBFJ43CA	36.8	40.9	45.2	1.0	59.3	10.1	5.0
P6SMBFJ47	P6SMBFJ47C	38.1	42.3	51.7	1.0	67.8	8.8	5.0
P6SMBFJ47A	P6SMBFJ47CA	40.2	44.7	49.4	1.0	64.8	9.3	5.0
P6SMBFJ51	P6SMBFJ51C	41.3	45.9	56.1	1.0	73.5	8.2	5.0
P6SMBFJ51A	P6SMBFJ51CA	43.6	48.5	53.6	1.0	70.1	8.6	5.0
P6SMBFJ56	P6SMBFJ56C	45.4	50.4	61.6	1.0	80.5	7.5	5.0
P6SMBFJ56A	P6SMBFJ56CA	47.8	53.2	58.8	1.0	77.0	7.8	5.0
P6SMBFJ62	P6SMBFJ62C	50.2	55.8	68.2	1.0	89.0	6.7	5.0
P6SMBFJ62A	P6SMBFJ62CA	53.0	58.9	65.1	1.0	85.0	7.1	5.0
P6SMBFJ68	P6SMBFJ68C	55.1	61.2	74.8	1.0	98.0	6.1	5.0
P6SMBFJ68A	P6SMBFJ68CA	58.1	64.6	71.4	1.0	92.0	6.5	5.0
P6SMBFJ75	P6SMBFJ75C	60.7	67.5	82.5	1.0	108	5.6	5.0
P6SMBFJ75A	P6SMBFJ75CA	64.1	71.3	78.8	1.0	103	5.8	5.0



TYPE		Reverse Stand-Off Voltage	Breakdown Voltage Min. @I _T	Breakdown Voltage Max. @ I _T	Test Current	Maximum Clamping Voltage @I _{PP}	Peak Pulse Current	Reverse Leakage @V _{RWM}
(Uni)	(Bi)	V _{RWM} (V)	V _{BR MIN} (V)	V _{BR MAX} (V)	I _T (mA)	V _C (V)	I _{PP} (A)	I _R (uA)
P6SMBFJ82	P6SMBFJ82C	66.4	73.8	90.2	1.0	118	5.1	5.0
P6SMBFJ82A	P6SMBFJ82CA	70.1	77.9	86.1	1.0	113	5.3	5.0
P6SMBFJ91	P6SMBFJ91C	73.7	81.9	100	1.0	131	4.6	5.0
P6SMBFJ91A	P6SMBFJ91CA	77.8	86.5	95.5	1.0	125	4.8	5.0
P6SMBFJ100	P6SMBFJ100C	81.0	90.0	110	1.0	144	4.2	5.0
P6SMBFJ100A	P6SMBFJ100CA	85.5	95.0	105	1.0	137	4.4	5.0
P6SMBFJ110	P6SMBFJ110C	89.2	99.0	121	1.0	158	3.8	5.0
P6SMBFJ110A	P6SMBFJ110CA	94.0	105	116	1.0	152	3.9	5.0
P6SMBFJ120	P6SMBFJ120C	97.2	108	132	1.0	173	3.5	5.0
P6SMBFJ120A	P6SMBFJ120CA	102	114	126	1.0	165	3.6	5.0
P6SMBFJ130	P6SMBFJ130C	105	117	143	1.0	187	3.2	5.0
P6SMBFJ130A	P6SMBFJ130CA	111	124	137	1.0	179	3.4	5.0
P6SMBFJ150	P6SMBFJ150C	121	135	165	1.0	215	2.8	5.0
P6SMBFJ150A	P6SMBFJ150CA	128	143	158	1.0	207	2.9	5.0
P6SMBFJ160	P6SMBFJ160C	130	144	176	1.0	230	2.6	5.0
P6SMBFJ160A	P6SMBFJ160CA	136	152	168	1.0	219	2.7	5.0
P6SMBFJ170	P6SMBFJ170C	138	153	187	1.0	244	2.5	5.0
P6SMBFJ170A	P6SMBFJ170CA	145	162	179	1.0	234	2.6	5.0
P6SMBFJ180	P6SMBFJ180C	146	162	198	1.0	258	2.3	5.0
P6SMBFJ180A	P6SMBFJ180CA	154	171	189	1.0	246	2.4	5.0
P6SMBFJ200	P6SMBFJ200C	162	180	220	1.0	287	2.1	5.0
P6SMBFJ200A	P6SMBFJ200CA	171	190	210	1.0	274	2.2	5.0
P6SMBFJ220	P6SMBFJ220C	175	198	242	1.0	344	1.7	5.0
P6SMBFJ220A	P6SMBFJ220CA	185	209	231	1.0	328	1.8	5.0
P6SMBFJ250	P6SMBFJ250C	202	225	275	1.0	360	1.7	5.0
P6SMBFJ250A	P6SMBFJ250CA	214	237	263	1.0	344	1.7	5.0
P6SMBFJ300	P6SMBFJ300C	243	270	330	1.0	430	1.4	5.0
P6SMBFJ300A	P6SMBFJ300CA	256	285	315	1.0	414	1.4	5.0
P6SMBFJ350	P6SMBFJ350C	284	315	385	1.0	504	1.2	5.0
P6SMBFJ350A	P6SMBFJ350CA	300	333	368	1.0	482	1.2	5.0
P6SMBFJ400	P6SMBFJ400C	324	360	440	1.0	574	1.0	5.0
P6SMBFJ400A	P6SMBFJ400CA	342	380	420	1.0	548	1.1	5.0
P6SMBFJ440	P6SMBFJ440C	356	396	484	1.0	631	0.95	5.0
P6SMBFJ440A	P6SMBFJ440CA	376	418	462	1.0	602	1.0	5.0

Ratings and Characteristic Curves $T_A=25^\circ\text{C}$ unless otherwise noted

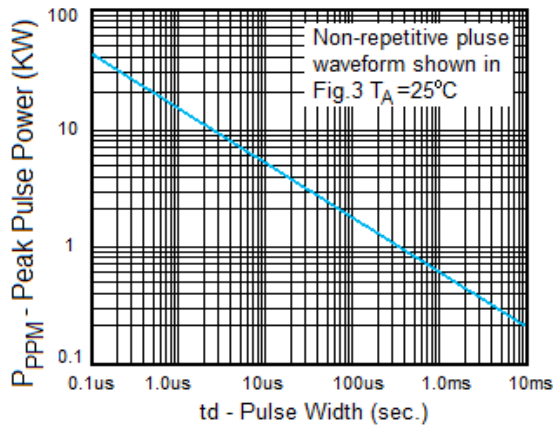

Fig. 1 Peak Pulse Power Rating

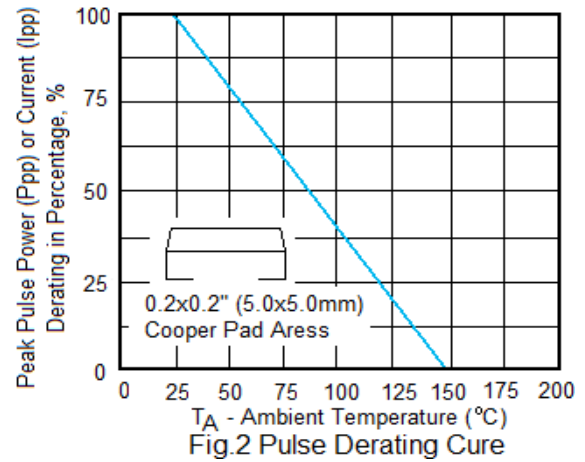

Fig. 2 Pulse Derating Curve

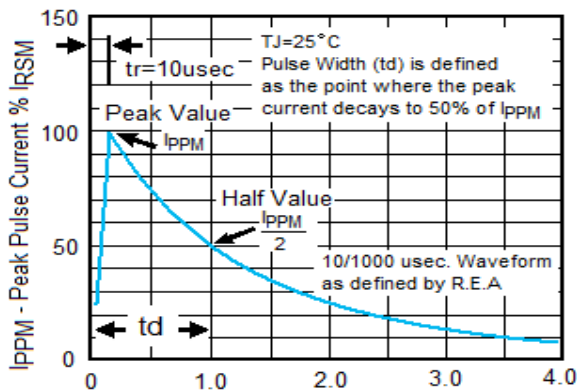

Fig. 3 Pulse Waveform

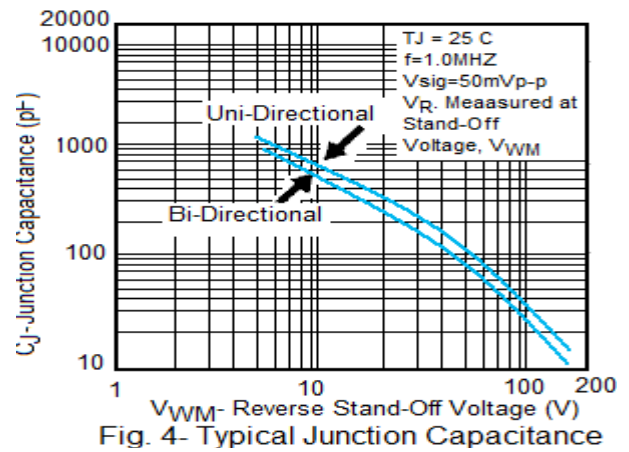

Fig. 4- Typical Junction Capacitance