

High Efficiency Low Noise PFM Step-Up DC/DC Converter

UM1661 SOT23-6

General Description

The UM1661 PFM step-up DC/DC Converter drives white LEDs with a constant current to provide backlight in cell phones, PDAs, and other hand-held devices. It features allowing series connection of the white LEDs so that the LED currents are identical for uniform brightness. An enable input can be pulsed repeatedly to adjust LEDs brightness. The fast 500kHz to 2MHz operation frequency allows for smaller capacitor and inductor. Fault condition protection uses cycle-by-cycle current limiting to sense maximum inductor current and over-voltage protection. The 0.2V low reference voltage minimizes the power loss across the current sense resistor. The converter can operate from 2V to 6V, and capable of delivering maximum 200mA output current at 4-LEDs application with 3V input voltage. Quiescent current drawn from power source is as low as 120uA. All of these features make UM1661 be suitable for the portable devices, which are supplied by a single battery.

Applications

- Compact Back Light Module
- Power Source for LED
- Constant Current Source

Features

- Up to 24V Output Voltage
- Wide Operation Range: 2V to 6V
- Maximum 2MHz Operating Frequency
- PWM Dimming Control
- Shutdown Current <1μA
- Current Limit Cycle-by-Cycle
- Low Current Sense Threshold: 200mV
- 24V Over Output Voltage Protection
- Compact SOT23-6 Package

Pin Configurations

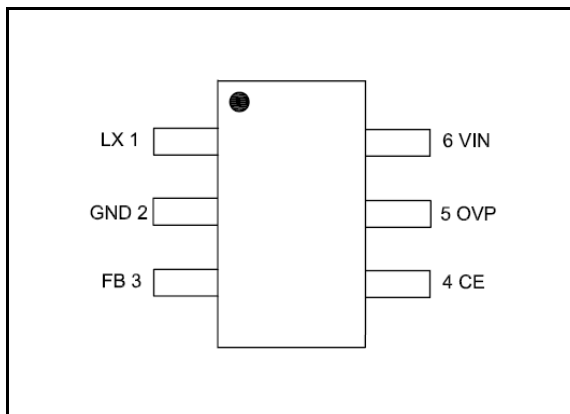

Top View

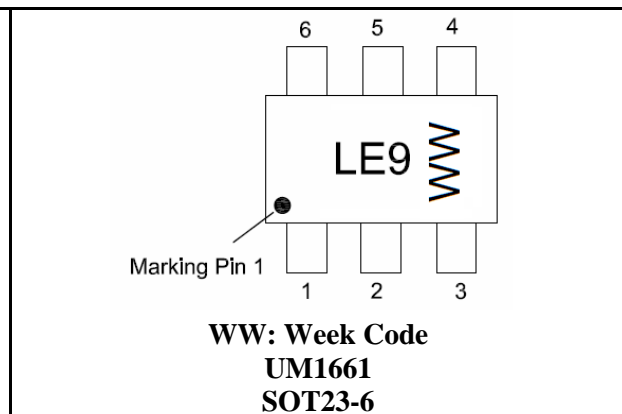

Ordering Information

Part Number	Packaging Type	Marking Code	Shipping Qty
UM1661	SOT23-6	LE9	3000pcs/7Inch Tape & Reel

Pin Description

Pin Number	Symbol	Function
1	LX	Switching Pin
2	GND	Ground Pin
3	FB	Pin for Feedback Voltage
4	CE	Chip Enable Pin (Active with “H”)
5	OVP	Over Voltage Protection
6	VIN	Power Supply Pin

Absolute Maximum Ratings

Symbol	Parameter	Value	Unit
V _{IN}	Supply Voltage on VIN	-0.3 to +8.0	V
V _{CE}	Voltages on Pin CE	-0.3 to V _{IN} +0.3	V
I _{LX}	LX Pin Output Current	1.6	A
V _{LX}	LX Pin Voltage	24	V
P _D	Continuous Power Dissipation	250	mW
T _A	Operating Ambient Temperature	-40 to +85	°C
T _J	Operating Junction Temperature	+125	°C
T _{STG}	Storage Temperature Range	-40 to +150	°C
T _L	Maximum Lead Temperature for Soldering 10 Seconds	+260	°C

Electrical Characteristics

(V_{IN}=3.0V, V_{CE}=3.0V, T_A=25°C, unless otherwise noted)

Symbol	Parameter	Test Conditions	Min	Typ	Max	Unit
V _{IN}	Input Voltage Range		2.0		6.0	V
V _{FB}	Feedback Voltage		0.190	0.200	0.210	V
I _{FB}	FB Pin Bias Current		10	45	100	nA
I _Q	Quiescent Current	V _{FB} =0.3V		93	120	μA
		V _{CE} =0V		0.4	1.0	
F _{OSC_MAX}	Maximum Switching Frequency	V _{FB} =0V		2		MHz
I _{Limit}	Switching Current Limit			1.6		A
V _{CESAT}	Switching V _{CESAT}	I _{LX} =300mA		260		mV
I _{LX}	Switching Pin Leak Current	V _{LX} =5V		0.11		μA
V _{CEH}	CE Voltage High	CE=0V to 3V	1.5			V
V _{CEL}	CE Voltage Low	CE=3V to 0V			0.4	V
I _{CE}	CE pin Bias Current			18		μA
V _{OVP}	Over Voltage Protection			24		V

Function Block Diagram

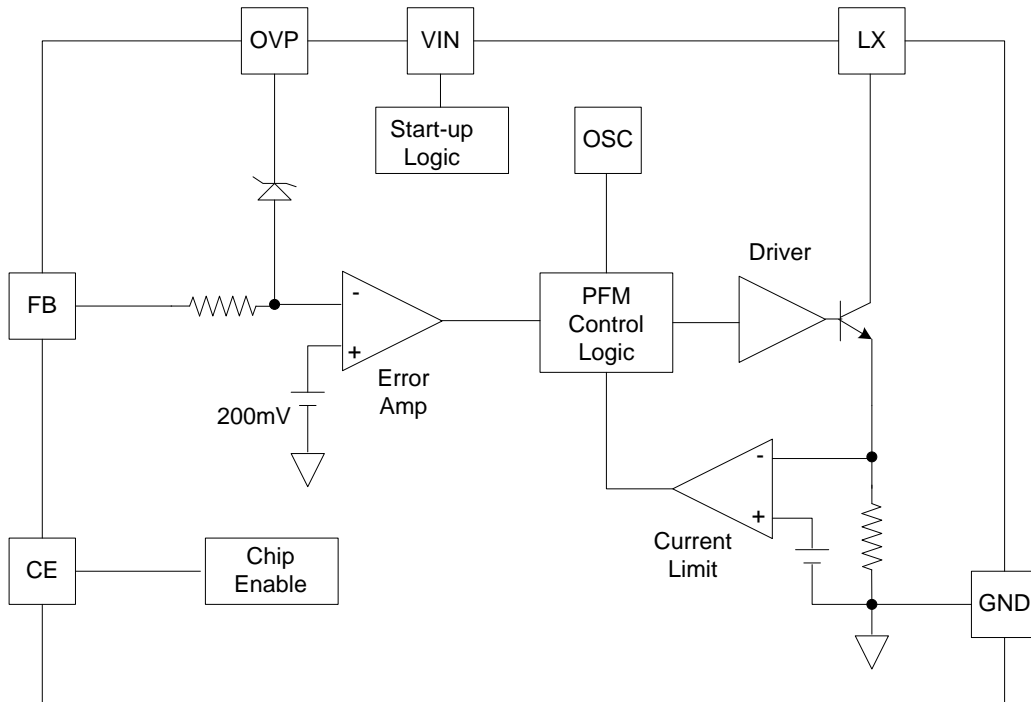

Typical Application Circuit

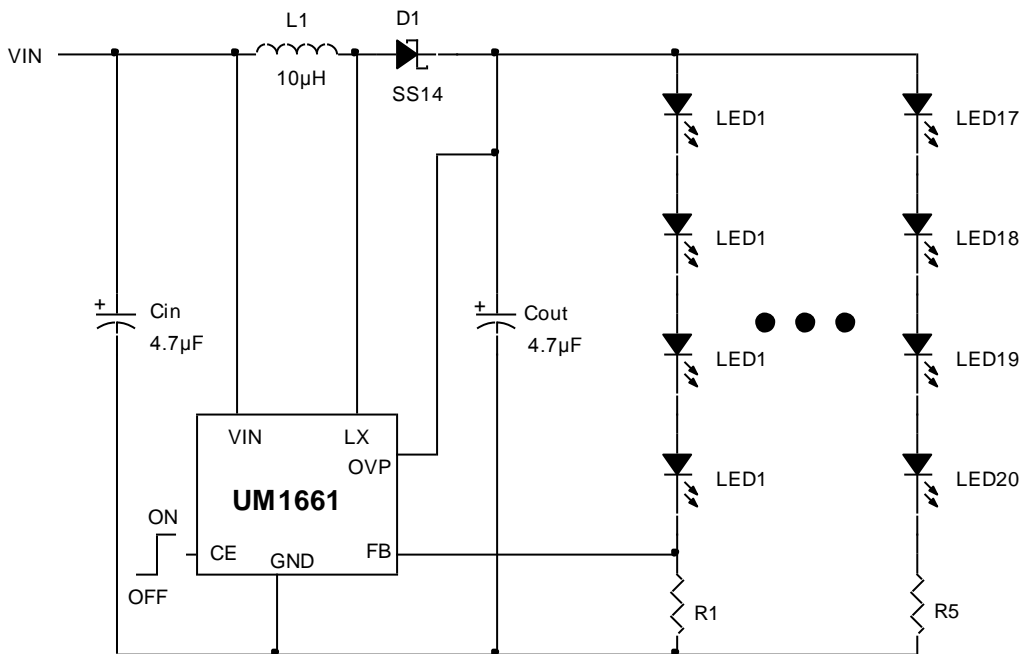

Typical Operating Characteristics

($V_{IN}=3.0V$, $V_{CE}=3.0V$, $T_A=25^\circ C$, unless otherwise noted)

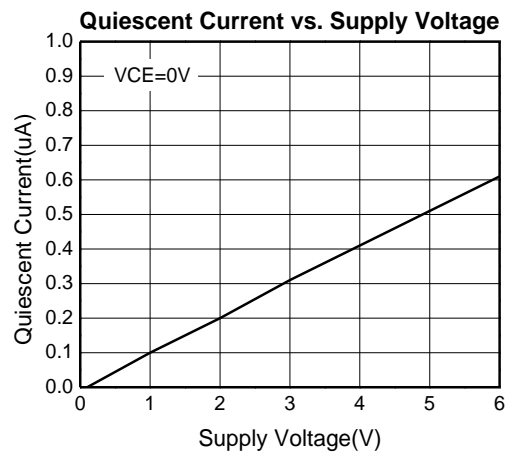
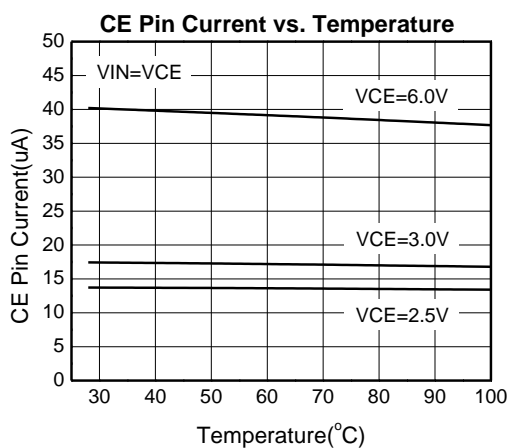
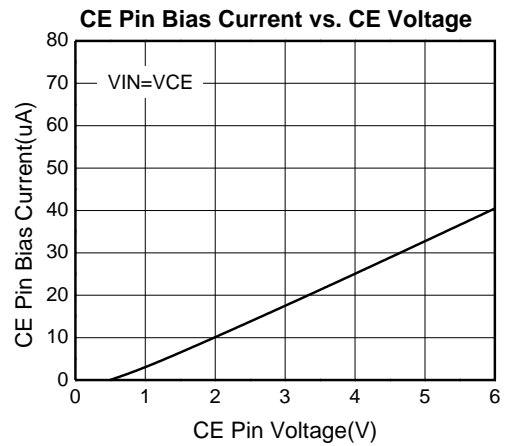
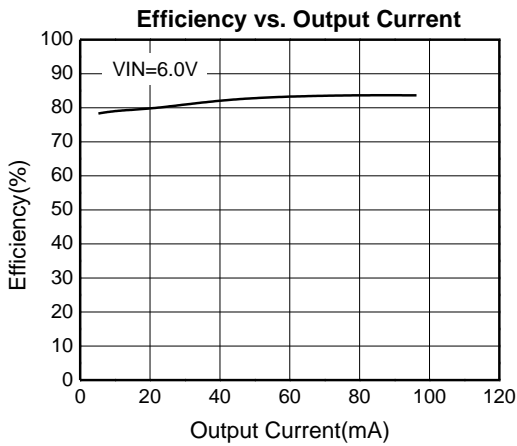
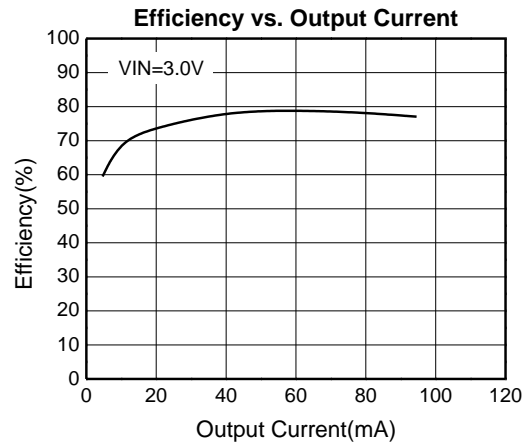
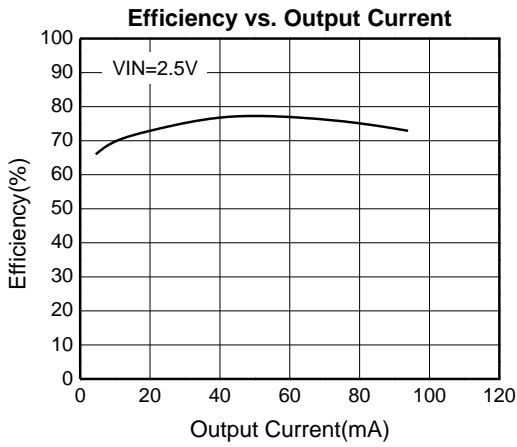

Typical Operating Characteristics (Continued)

($V_{IN}=3.0V$, $V_{CE}=3.0V$, $T_A=25^\circ C$, unless otherwise noted)

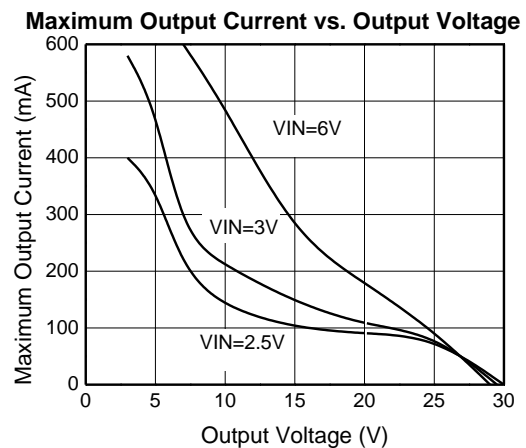
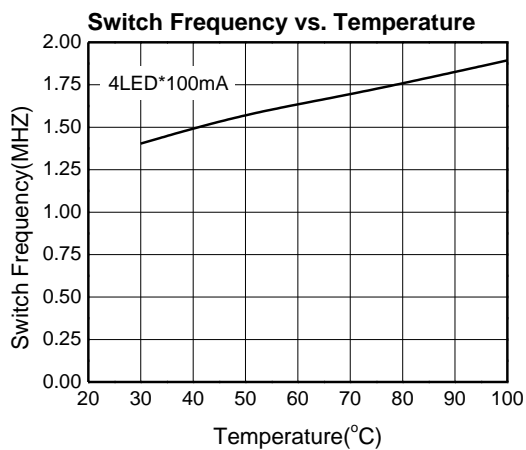
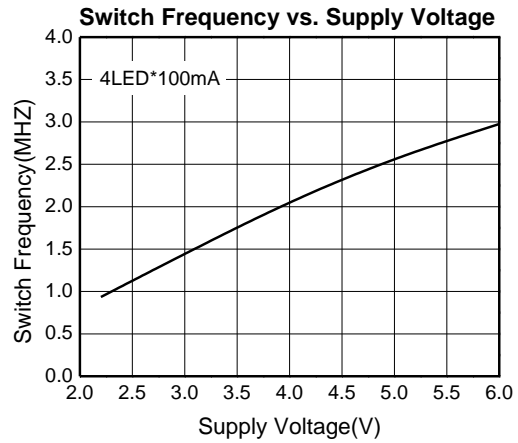
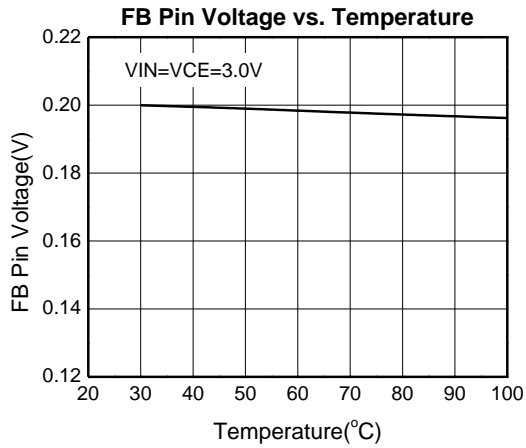
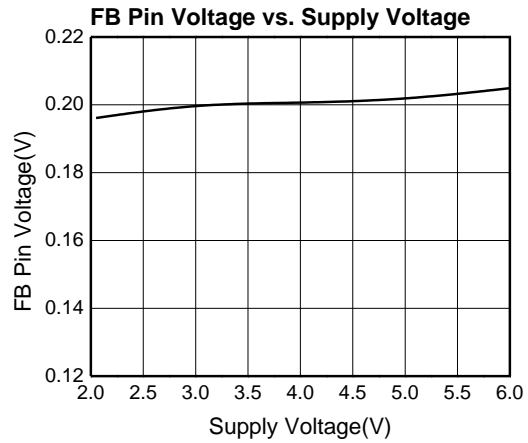
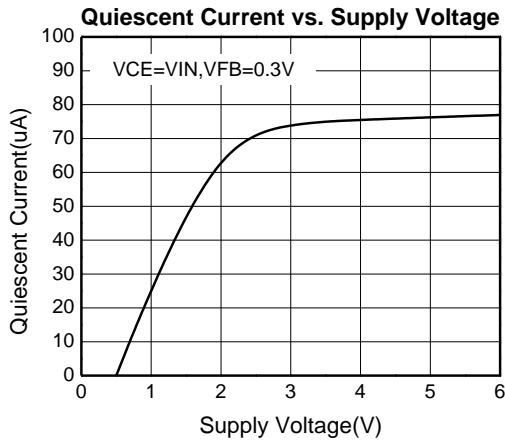

Application Information

LED Current Control

The UM1661 regulates the LED current by setting the current sense resistor (R1) connecting to feedback and ground. The UM1661 feedback voltage (V_{FB}) is 0.20V. The LED current (I_{LED}) can be set by a resistor R1. $I_{LED}=0.20/R1$. In order to have an accurate LED current, a precision resistor is preferred (1% is recommended).

PWM Dimming Control

When adding the PWM signal to CE pin, the UM1661 is turned on or off by the PWM signal, so the LEDs operate at either zero or full current. The average LED current increase proportionally with the duty cycle of the PWM signal. The magnitude of the PWM signal should be higher than the maximum enable voltage of EN pin, in order to let the dimming control perform correctly. The recommended frequency range of the PWM signal is from 100Hz to 100 kHz.

Inductor Selection

The recommended value of inductor is 2.2 μ H to 10 μ H. Small size and better efficiency are the major concerns for portable device, such as UM1661 used for mobile phone. The inductor should have low core loss at 2MHz and low DCR for better efficiency. To avoid inductor saturation current rating should be considered.

Capacitor Selection

Input and output ceramic capacitors of 4.7 μ F are recommended for UM1661 applications. For better voltage filtering, ceramic capacitors with low ESR are recommended. X5R and X7R types are suitable because of their wider voltage and temperature ranges.

Diode Selection

Schottky diode is a good choice for UM1661 because of its low forward voltage drop and fast reverse recovery. Using Schottky diode can get better efficiency. The high speed rectification is also a good characteristic of Schottky diode for high switching frequency. Current rating of the diode must meet the root mean square of the peak current and output average current multiplication as following:

$$I_{D(RMS)} \approx (I_{OUT} \times I_{PEAK})^{1/2}$$

The diode's reverse breakdown voltage should be larger than the output voltage. SS0520 is recommended Schottky diode for rectifier.

Layout Guide

- A full GND plane without gap break.
- Minimized LX node copper area to reduce EMI.
- Minimized FB node copper area and keep far away from noise sources.

Package Information

UM1661: SOT23-6

Outline Drawing

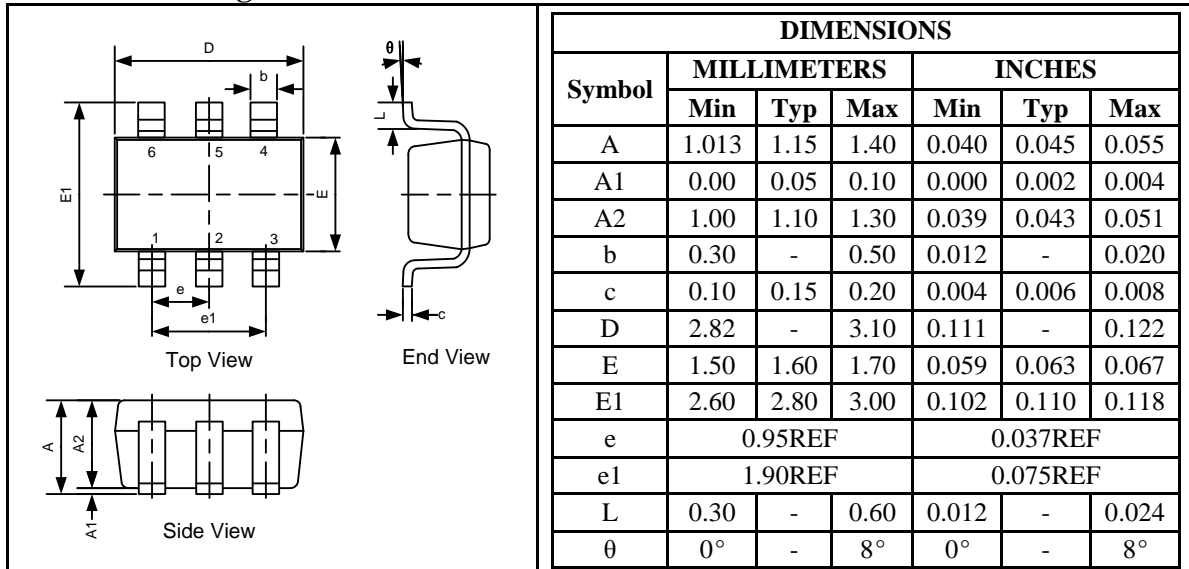

Land Pattern

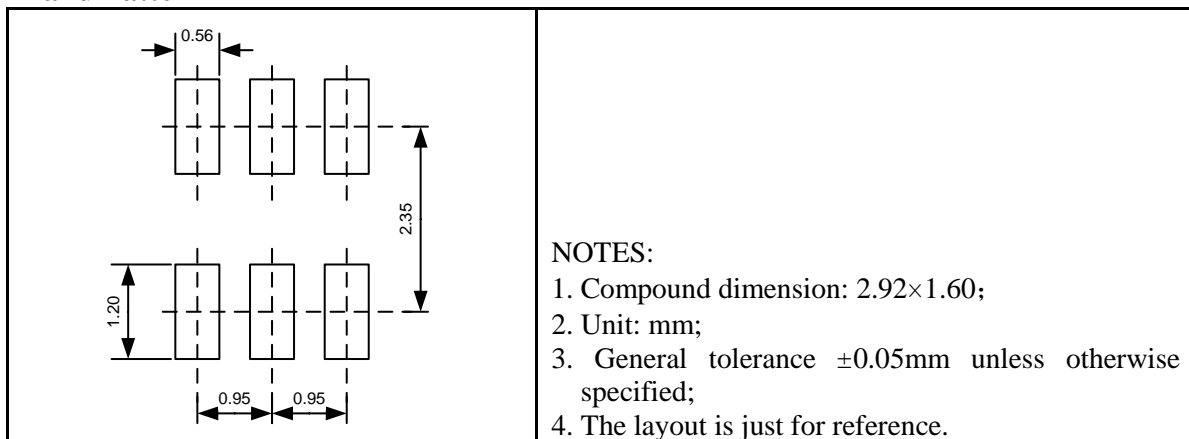

Tape and Reel Orientation



GREEN COMPLIANCE

Union Semiconductor is committed to environmental excellence in all aspects of its operations including meeting or exceeding regulatory requirements with respect to the use of hazardous substances. Numerous successful programs have been implemented to reduce the use of hazardous substances and/or emissions.

All Union components are compliant with the RoHS directive, which helps to support customers in their compliance with environmental directives. For more green compliance information, please visit:

http://www.union-ic.com/index.aspx?cat_code=RoHSDeclaration

IMPORTANT NOTICE

The information in this document has been carefully reviewed and is believed to be accurate. Nonetheless, this document is subject to change without notice. Union assumes no responsibility for any inaccuracies that may be contained in this document, and makes no commitment to update or to keep current the contained information, or to notify a person or organization of any update. Union reserves the right to make changes, at any time, in order to improve reliability, function or design and to attempt to supply the best product possible.



Union Semiconductor, Inc

Add: Unit 606, No.570 Shengxia Road, Shanghai 201210

Tel: 021-51093966

Fax: 021-51026018

Website: www.union-ic.com