

# STD181GKXXB

## Thyristor-Diode Modules

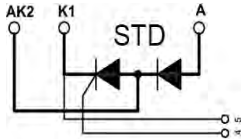
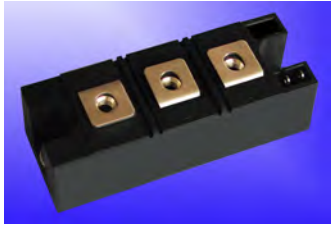

Type	$V_{RSM}$ $V_{DSM}$ V	$V_{RRM}$ $V_{DRM}$ V
STD181GK08B	900	800
STD181GK12B	1300	1200
STD181GK14B	1500	1400
STD181GK16B	1700	1600
STD181GK18B	1900	1800
STD181GK20B	2100	2000
STD181GK22B	2300	2200

Dimensions in mm (1mm=0.0394")

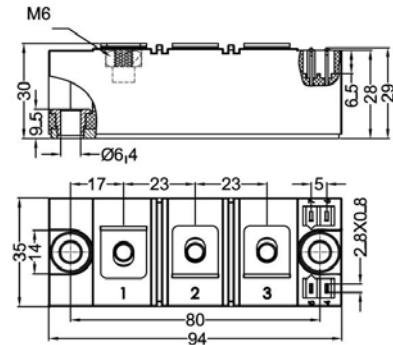

Symbol	Test Conditions	Maximum Ratings	Unit
$I_{TRMS}$ , $I_{FRMS}$ $I_{TAVM}$ , $I_{FAVM}$	$T_VJ = T_{VJM}$ $T_C = 85^\circ\text{C}$ ; 180° sine	300 181	A
$I_{TSM}$ , $I_{FSM}$	$T_VJ = 45^\circ\text{C}$ $V_R = 0$ $t = 10\text{ms}$ (50Hz), sine $t = 8.3\text{ms}$ (60Hz), sine	6000 6400	A
	$T_VJ = T_{VJM}$ $V_R = 0$ $t = 10\text{ms}$ (50Hz), sine $t = 8.3\text{ms}$ (60Hz), sine	5250 5600	
$\int i^2 dt$	$T_VJ = 45^\circ\text{C}$ $V_R = 0$ $t = 10\text{ms}$ (50Hz), sine $t = 8.3\text{ms}$ (60Hz), sine	180000 170000	$\text{A}^2\text{s}$
	$T_VJ = T_{VJM}$ $V_R = 0$ $t = 10\text{ms}$ (50Hz), sine $t = 8.3\text{ms}$ (60Hz), sine	137000 128000	
$(di/dt)_{cr}$	$T_VJ = T_{VJM}$ $f = 50\text{Hz}$ , $t_p = 200\mu\text{s}$ $V_D = 2/3 V_{DRM}$ $I_G = 0.5\text{A}$ $di_G/dt = 0.5\text{A}/\mu\text{s}$ repetitive, $I_T = 500\text{A}$	150	A/us
	non repetitive, $I_T = I_{TAVM}$	500	
$(dv/dt)_{cr}$	$T_VJ = T_{VJM}$ ; $R_{GK} = \infty$ ; method 1 (linear voltage rise) $V_{DR} = 2/3 V_{DRM}$	1000	V/us
$P_{GM}$	$T_VJ = T_{VJM}$ $I_T = I_{TAVM}$ $t_p = 30\mu\text{s}$ $t_p = 500\mu\text{s}$	120 60	W
		8	
$P_{GAV}$		10	W
$V_{RGM}$		10	V
$T_{VJ}$ $T_{VJM}$ $T_{stg}$		-40...+125	$^\circ\text{C}$
		125	
		-40...+125	
$V_{ISOL}$	50/60Hz, RMS $I_{ISOL} \leq 1\text{mA}$ $t = 1\text{min}$ $t = 1\text{s}$	3000 3600	V~
$M_d$	Mounting torque (M6) Terminal connection torque (M6)	2.25-2.75/20-25 4.5-5.5/40-48	Nm/lb.in.
Weight	Typical	173	g



# STD181GKXXB

## Thyristor-Diode Modules

Symbol	Test Conditions	Characteristic Values	Unit
$I_{RRM}, I_{DRM}$	$T_{VJ}=T_{VJM}; V_R=V_{RRM}; V_D=V_{DRM}$	40	mA
$V_T, V_F$	$I_T, I_F=540A; T_{VJ}=25^{\circ}C$	1.65	V
$V_{TO}$	For power-loss calculations only ( $T_{VJ}=T_{VJM}$ )	0.8	V
$r_T$		1.6	$m\Omega$
$V_{GT}$	$V_D=6V; T_{VJ}=25^{\circ}C$ $T_{VJ}=-40^{\circ}C$	2 2.6	V
$I_{GT}$	$V_D=6V; T_{VJ}=25^{\circ}C$ $T_{VJ}=-40^{\circ}C$	150 200	mA
$V_{GD}$	$T_{VJ}=T_{VJM}; V_D=2/3V_{DRM}$	0.25	V
$I_{GD}$	$T_{VJ}=T_{VJM}; V_D=2/3V_{DRM}$	10	mA
$I_L$	$T_{VJ}=25^{\circ}C; t_p=30\mu s; V_D=6V$ $I_G=0.45A; di_G/dt=0.45A/\mu s$	200	mA
$I_H$	$T_{VJ}=25^{\circ}C; V_D=6V; R_{GK}=\infty$	150	mA
$t_{gd}$	$T_{VJ}=25^{\circ}C; V_D=1/2V_{DRM}$ $I_G=0.5A; di_G/dt=0.5A/\mu s$	2	$\mu s$
$t_q$	$T_{VJ}=T_{VJM}; I_T=160A; t_p=200\mu s; -di/dt=10A/\mu s$ $V_R=100V; dv/dt=20V/\mu s; V_D=2/3V_{DRM}$	150	$\mu s$
$Q_s$	$T_{VJ}=T_{VJM}; I_T, I_F=300A; -di/dt=50A/\mu s$	550	$\mu C$
$I_{RM}$		235	A
$R_{thJC}$	per thyristor/diode; DC current per module	0.155 0.0775	K/W
$R_{thJK}$	per thyristor/diode; DC current per module	0.225 0.1125	K/W
$d_s$	Creeping distance on surface	12.7	mm
$d_A$	Creepage distance in air	9.6	mm
$a$	Maximum allowable acceleration	50	$m/s^2$

### FEATURES

- \* International standard package
- \* Copper base plate
- \* Glass passivated chips
- \* Isolation voltage 3600 V~
- \* UL file NO.E310749
- \* RoHS compliant

### APPLICATIONS

- \* Motor control
- \* Power converter
- \* Heat and temperature control for industrial furnaces and chemical processes
- \* Lighting control
- \* Contactless switches

### ADVANTAGES

- \* Space and weight savings
- \* Simple mounting
- \* Improved temperature and power cycling
- \* Reduced protection circuits



# STD181GKxx B

## Thyristor-Diode Modules

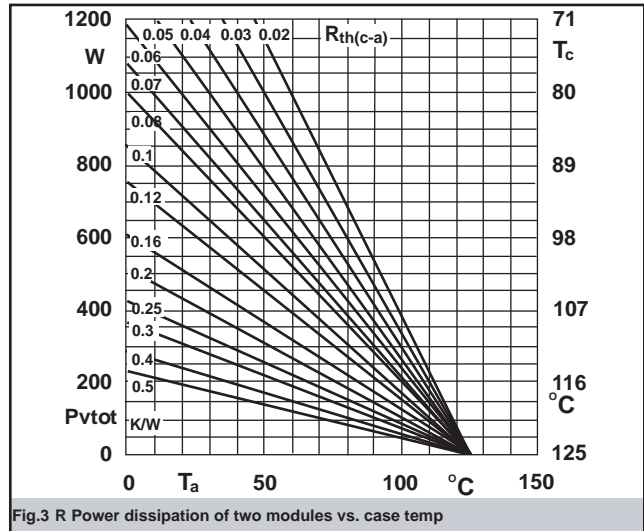
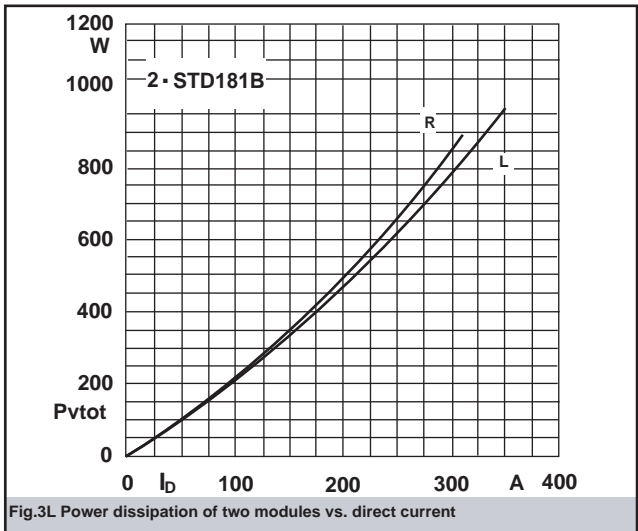
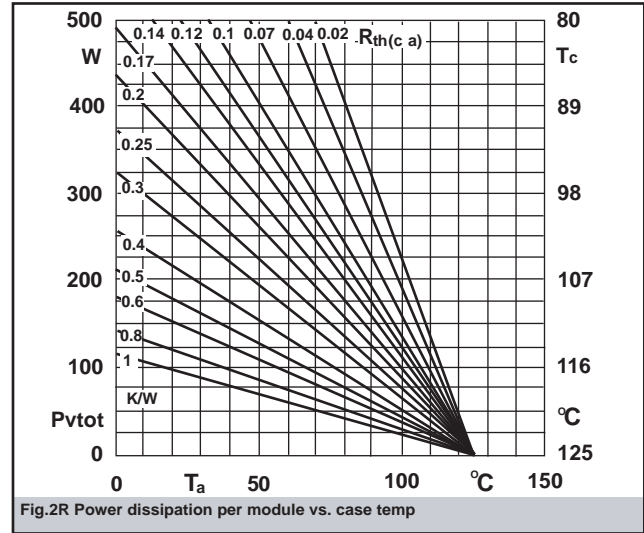
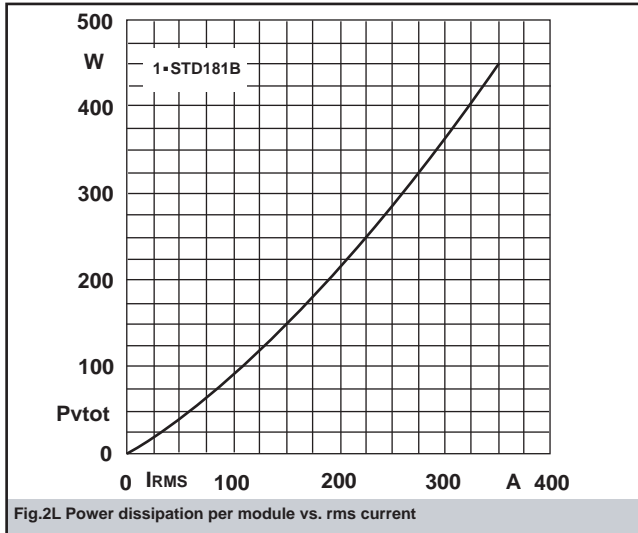
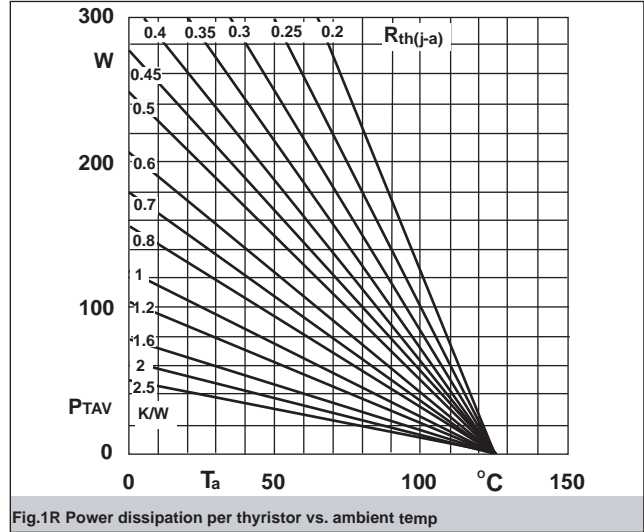
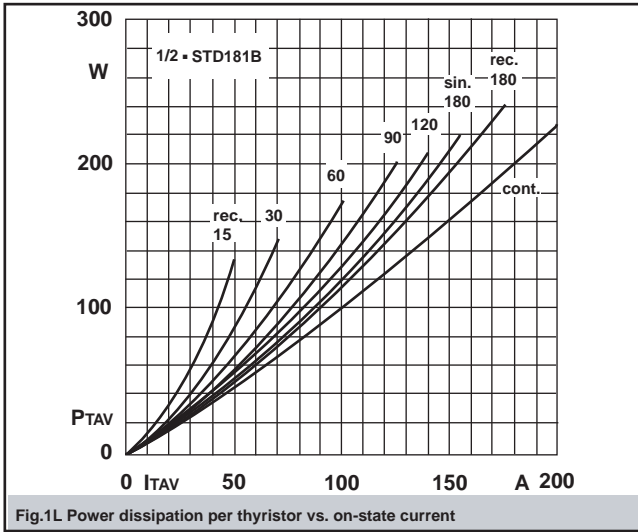

# STD181GKxx B

## Thyristor-Diode Modules

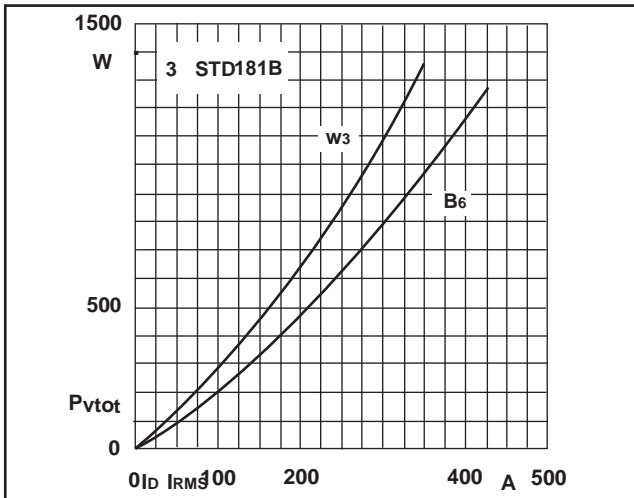

Fig.4L Power dissipation of three modules vs. direct and rms current

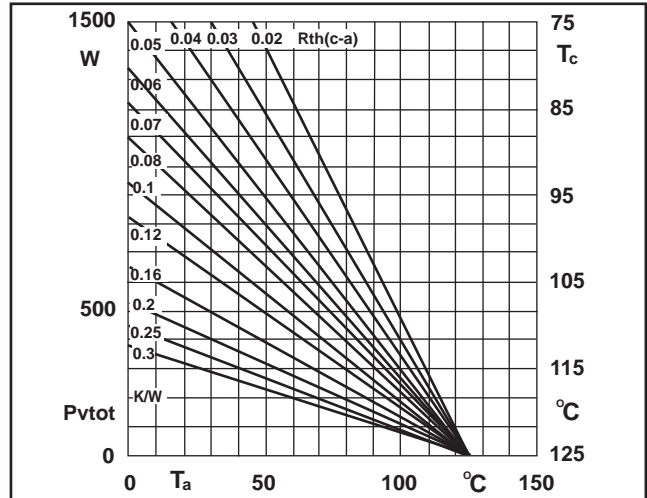

Fig.4R Power dissipation of three modules vs. case temp

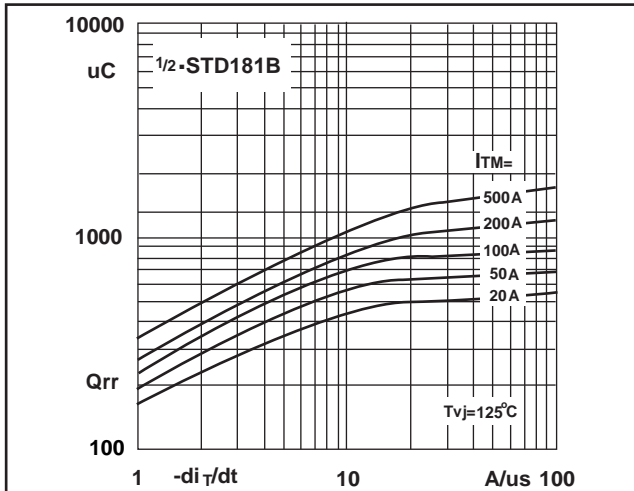

Fig.5 Recovered charge vs. current decrease

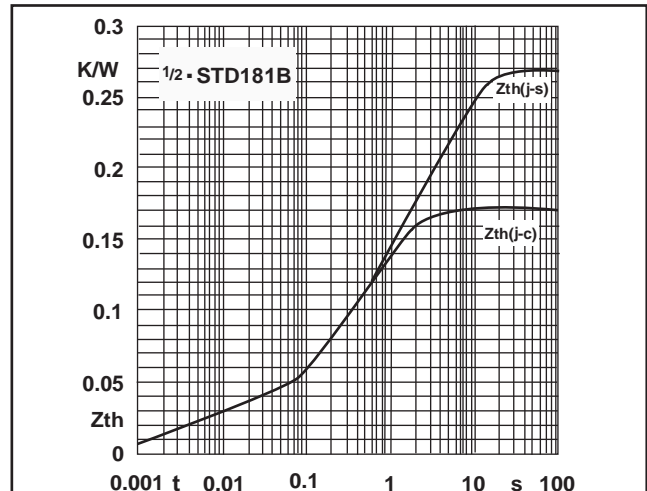

Fig.6 Transient thermal impedance vs. time

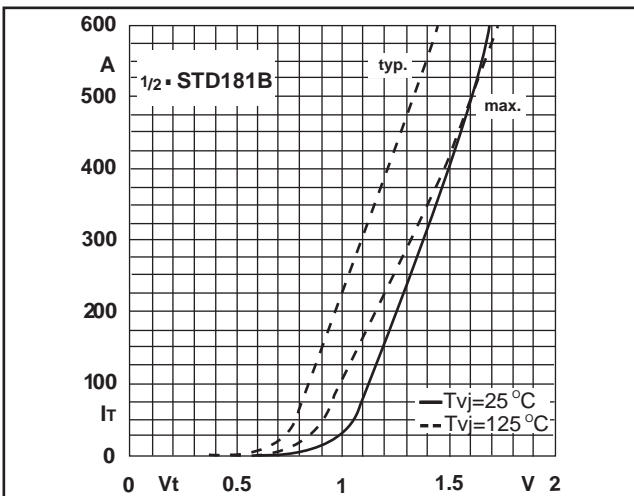

Fig.7 On-state characteristics

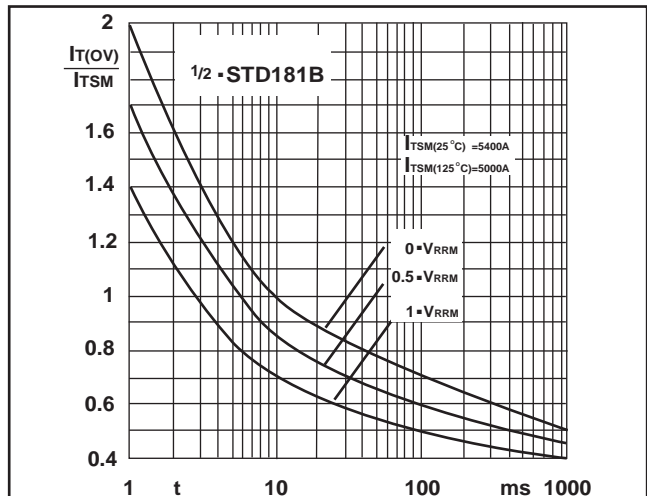

Fig.8 Surge overload current vs. time

