



Thin-Film Cascadable Amplifier 1 to 2000 MHz

Technical Data

UTO/UTC 2031 Series

Features

- **Frequency Range: 1 to 2000 MHz**
- **Noise Figure: 4.0 dB (Typ)**
- **Medium Gain: 10.5 dB (Typ)**
- **Temperature Compensated**

Applications

- **IF/RF Amplification**

Description

The 2031 Series is a wideband thin-film bipolar RF amplifier using resistive feedback and active bias for temperature compensation and increased immunity to bias voltage variations. Low input/output VSWR is maintained by inductive tuning, and internal blocking capacitors couple the RF through the amplifier. The 2031 Series amplifiers are available in either the TO-8 hermetic case or connected TC-1A package.

Pin Configuration

UTO—TO-8U

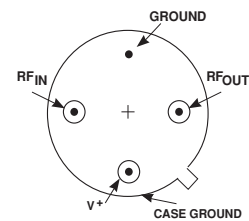

UTC—TC-1A

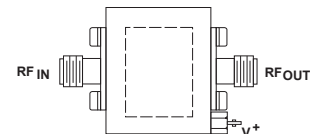

Schematic

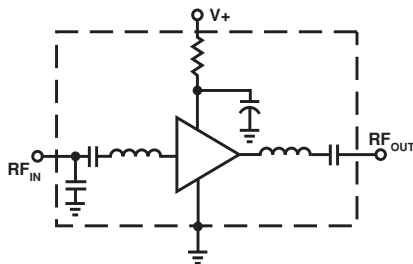

Maximum Ratings

Parameter	Maximum
DC Voltage	+17 Volts
Continuous RF Input Power	+13 dBm
Operating Case Temperature	-55 to +125°C
Storage Temperature	-62 to +150°C
“R” Series Burn-In Temperature	+125°C

Thermal Characteristics¹

θ_{JC}	105°C/W
Active Transistor Power Dissipation	126 mW
Junction Temperature Above Case Temperature	13°C
MTBF (MIL-HDBK-217E, A_{UF} @ 90°C)	685,900 Hrs.

Weight: (typical) UTO—2.1 grams; UTC—21.5 grams

Electrical Specifications

(Measured in 50 Ω system @ +15 VDC nominal unless otherwise noted)

Symbol	Characteristic	Typical $T_C = 25^\circ\text{C}$	Guaranteed Specifications		Unit
			$T_C = 0$ to 50°C	$T_C = -55$ to $+85^\circ\text{C}$	
BW	Frequency Range	1-2000	1-2000	1-2000	MHz
GP	Small Signal Gain (Min.)	10.5	9.0 Min.	8.5	dB
—	Gain Flatness (Max.)	± 0.6	± 1.0	± 1.0	dB
NF	Noise Figure (Max.)	4.0	5.5	5.5	dB
P_{1dB}	Power Output @ +1 dB Comp. (Min.)	+3.0	+2.0	+2.0	dBm
—	Input VSWR (Max.)	<1.5:1	2.0:1	2.0:1	—
—	Output VSWR (Max.)	<1.5:1	2.0:1	2.0:1	—
IP_3	Two Tone 3rd Order Intercept Point	+14.0	—	—	dBm
I_D	DC Current	16	—	—	mA

Typical Performance Over Temperature (@ +15 VDC unless otherwise noted)

Key: +25°C —
+85°C - - -
-55°C —

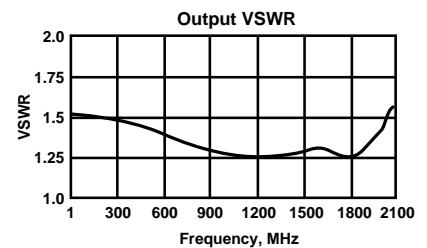
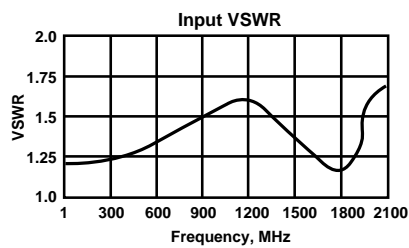
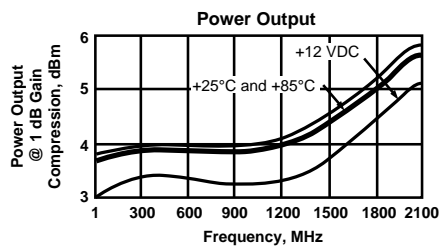
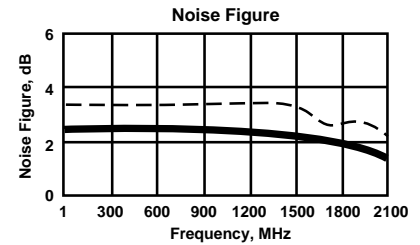
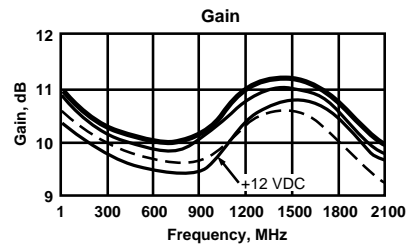

Automatic Network Analyzer Measurements (Typical production unit @ +25°C ambient)**Numerical Readings****Bias = 15.00 Volts**

FREQUENCY MHz	VSWR IN	GAIN dB	PHASE DEGREES	PHASE DEV	GROUP DELAY ns	VSWR OUT	ISOLATION dB
100.0	1.19	11.26	166.23	-6.03	.00	1.49	18.82
200.0	1.21	11.18	153.28	-5.27	.36	1.46	18.88
300.0	1.23	11.09	140.08	-4.74	.36	1.43	18.92
400.0	1.27	11.08	127.41	-3.69	.34	1.41	19.00
500.0	1.31	11.06	115.25	-2.14	.33	1.38	19.03
600.0	1.36	11.00	103.46	-.23	.33	1.35	19.08
700.0	1.42	10.96	91.63	1.64	.31	1.32	19.13
800.0	1.48	10.98	80.57	4.29	.33	1.30	19.20
900.0	1.54	11.04	68.43	5.88	.35	1.28	19.27
1000.0	1.59	11.14	55.49	6.63	.37	1.27	19.41
1100.0	1.61	11.31	41.97	6.81	.38	1.27	19.61
1200.0	1.60	11.44	27.77	6.31	.40	1.28	19.81
1300.0	1.55	11.50	12.82	5.07	.43	1.28	20.01
1400.0	1.47	11.53	-2.70	3.26	.43	1.29	20.08
1500.0	1.38	11.42	-18.15	1.53	.43	1.29	19.97
1600.0	1.29	11.24	-33.69	-.29	.44	1.28	19.77
1700.0	1.22	11.05	-49.74	-2.63	.44	1.25	19.50
1800.0	1.19	10.89	-65.46	-4.62	.44	1.24	19.23
1900.0	1.25	10.69	-81.19	-6.63	.45	1.25	18.93
2000.0	1.41	10.35	-97.89	-9.62	.48	1.35	18.78
2100.0	1.70	9.89	-115.76	—	.51	1.52	18.67
2200.0	2.15	9.24	-134.59	—	.54	1.76	18.82

S-Parameters**Bias = 15.00 Volts**

FREQUENCY MHz	S ₁₁		S ₂₁		S ₁₂		S ₂₂	
	Mag	Ang	dB	Ang	dB	Ang	Mag	Ang
100.00	.088	-171.5	11.224	186.2	-18.937	-6.7	.191	166.7
200.00	.094	-162.9	11.157	153.0	-18.895	-13.7	.188	154.2
300.00	.104	-156.4	11.064	139.8	-19.000	-20.3	.179	141.5
400.00	.117	-151.1	11.057	126.8	-19.069	-26.6	.172	129.2
500.00	.136	-149.1	11.036	114.7	-19.059	-33.7	.162	119.0
600.00	.157	-148.2	10.993	102.7	-19.064	-40.5	.151	108.4
700.00	.183	-150.3	10.979	90.8	-19.144	-48.0	.137	98.6
800.00	.207	-154.1	10.988	79.5	-19.215	-54.7	.126	88.4
900.00	.231	-160.5	11.062	67.3	-19.276	-60.7	.115	77.5
1000.00	.252	-167.2	11.177	54.3	-19.411	-67.6	.107	64.1
1100.00	.261	-175.4	11.352	40.6	-19.593	-74.6	.104	48.3
1200.00	.259	175.7	11.502	26.3	-19.812	-81.1	.105	29.3
1300.00	.243	165.6	11.616	11.1	-19.975	-86.7	.110	9.7
1400.00	.210	154.9	11.659	-4.6	-20.031	-92.5	.116	-10.1
1500.00	.171	144.0	11.544	-20.4	-19.874	-98.0	.119	-26.6
1600.00	.124	130.1	11.363	-36.1	-19.667	-104.0	.120	-39.2
1700.00	.080	104.0	11.174	-52.5	-19.411	-110.1	.118	-44.2
1800.00	.061	46.4	11.033	-68.6	-19.136	-117.3	.117	-41.6
1900.00	.108	-4.8	10.797	-84.6	-18.878	-125.9	.133	-34.1
2000.00	.192	-28.7	10.450	-101.6	-18.706	-135.7	.171	-29.2
2100.00	.299	-44.6	9.950	-119.5	-18.655	-146.5	.230	-31.7
2200.00	.415	-58.7	9.272	-138.4	-18.784	-158.3	.296	-39.5
2300.00	.521	-72.7	8.307	-157.7	-19.149	-170.6	.350	-49.4
2400.00	.615	-85.5	7.085	-176.6	-19.758	178.5	.386	-60.3
2500.00	.689	-97.2	5.641	165.3	-20.423	167.3	.402	-70.3

Product Options

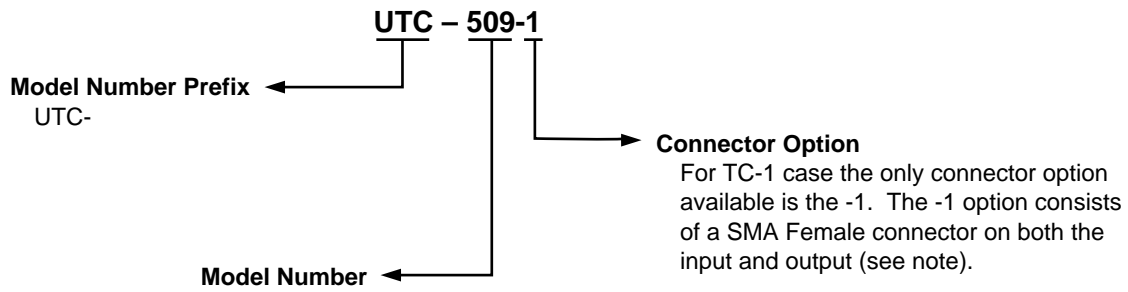
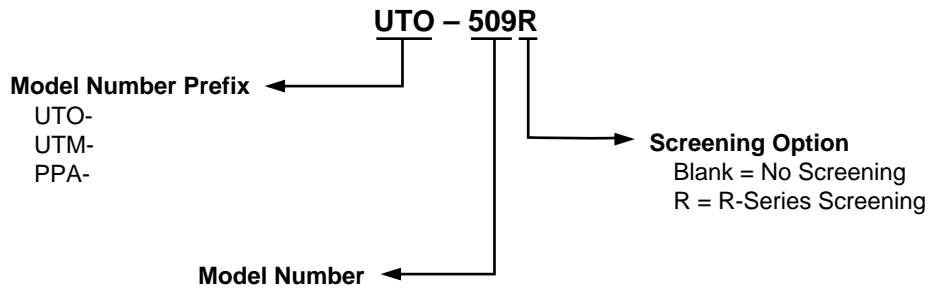

Note: R-Series screening is not available in the TC-1 case as the case is non-hermetic.

Case Drawings TO-8U

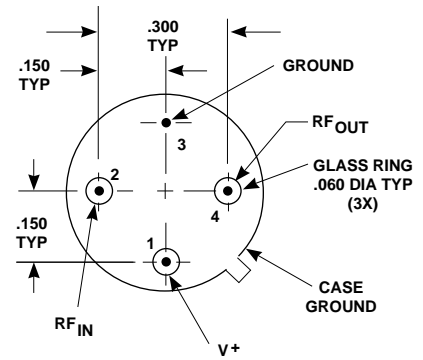
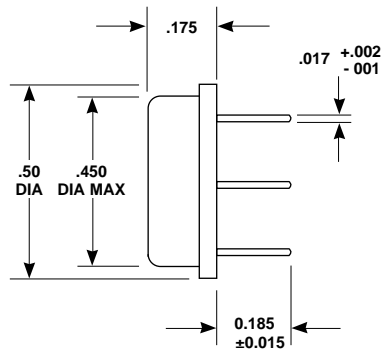
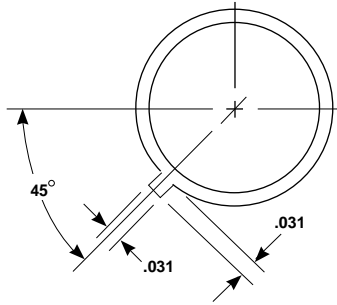

APPROXIMATE WEIGHT 2.1 GRAMS

NOTES (UNLESS OTHERWISE SPECIFIED):

1. DIMENSIONS ARE SPECIFIED IN INCHES
2. TOLERANCES: $xx \pm .02$
 $xxx \pm .010$

Case Drawings TC-1

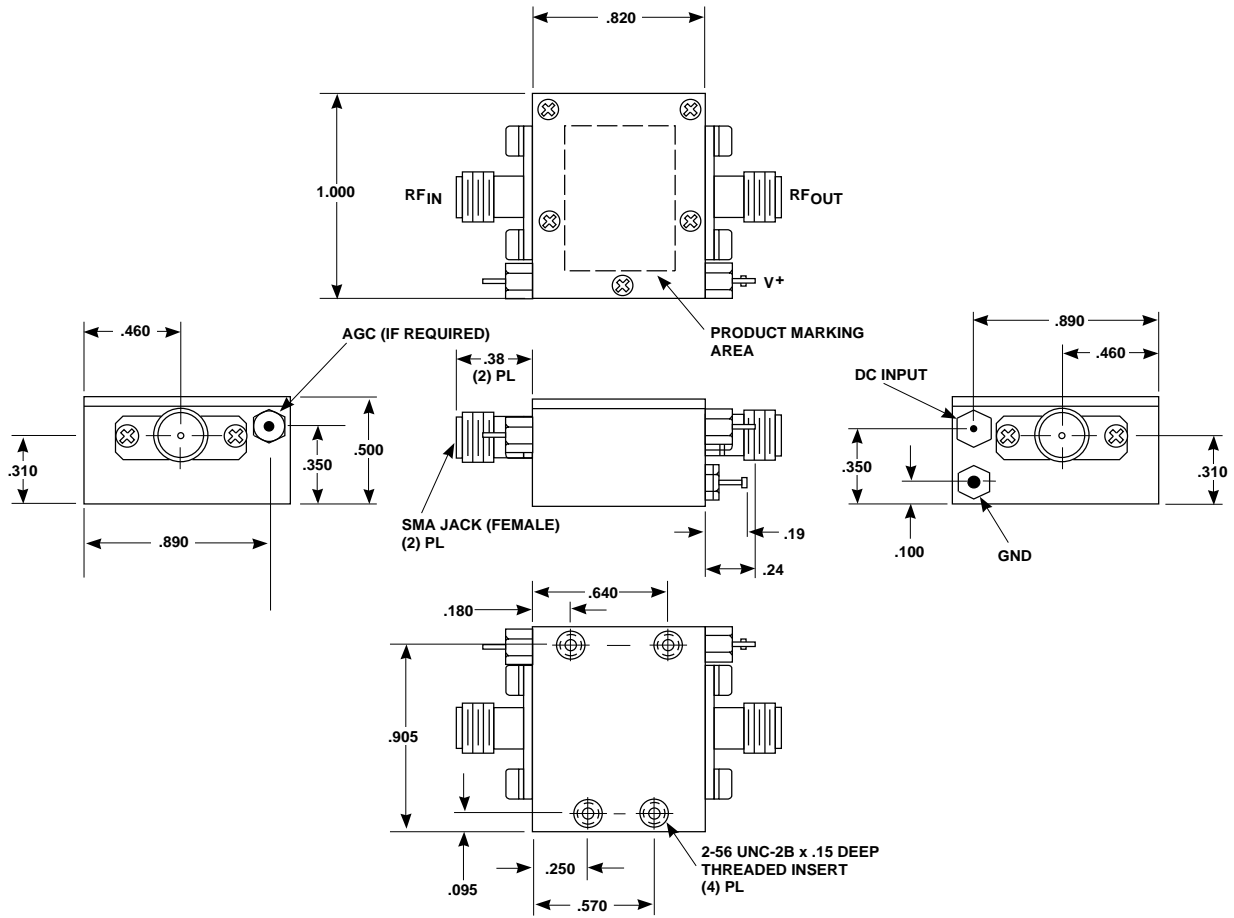

TYPICAL WEIGHT WITH CONNECTORS = 21.5 GRAMS

NOTES: 1. THE TC-1 CASE IS A NON-HERMETIC CASE.
2. THE ONLY CONNECTOR OPTION AVAILABLE FOR THE TC-1 CASE IS THE -1, SMA FEMALE CONNECTORS AT BOTH INPUT AND OUTPUT PORTS.

NOTES (UNLESS OTHERWISE SPECIFIED):
1. DIMENSIONS ARE SPECIFIED IN INCHES
2. TOLERANCES: xx ±.02
xxx ±.010

Contact Teledyne Microwave Solutions:
650-691-9800
650-962-6845 fax

Check for updates:
www.teledynemicrowave.com