

1. Mechanical Dimensions:

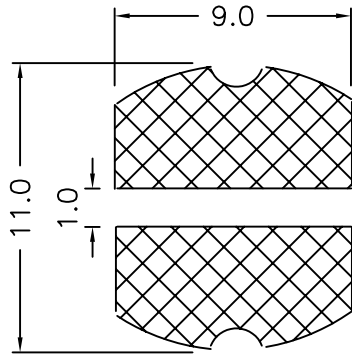

PAD LAYOUT

2. Schematic:

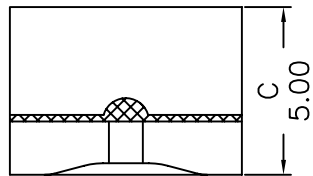
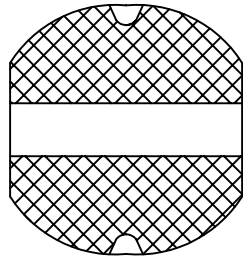
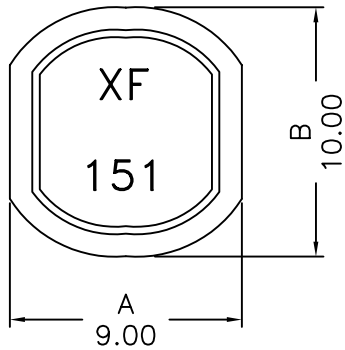
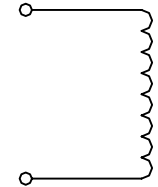

3. Electrical Specifications:

OCL: 150uH±20% @1.0KHz 1V

DCR: 0.510 Ohms Max

IDC: 0.55Adc Max

Notes:

1. Solderability: Leads shall meet MIL-STD-202, Method 208D for solderability.
2. Flammability: UL94V-0
3. ASTM oxygen index: > 28%
4. Temperature rating: 155°C. UL file E151556
5. Operating Temperature Range: -40°C to +85°C

DOC REV: A/2

XFMRs Inc		Title: INDUCTOR		
UNLESS OTHERWISE SPECIFIED TOLERANCES: .xx ±0.25 Dimensions in MM	P/N: XFSDR105SH-151M		REV. A	
	DWN.	罗振江	Sep-15-03	
	CHK.	廖玉坤	Sep-15-03	
SHT 1 OF 1		APP.	Isaiah M	Sep-15-03