

General Description

JJC' s SIDAC (Silicon Diode for Alternating Current) represents an unique set of thyristor qualities. The SIDAC is a bidirectional voltage triggered switch. Upon application of a voltage exceeding the sidac breakover voltage point, the sidac switches on through a negative resistance region to a low on-state voltage. conduction will continue until the current is interrupted or drops below the minimum holding current of the device.

At present, JINGHENG can offer three kinds of package in DO-41,R-1, Mini-MELF, SMA, SOD-123FL

JINGHENG's sidacs feature glass passivated junctions to ensure a rugged and dependable device capable of withstanding harsh environments.

Mini-MELF(DO-213AA)

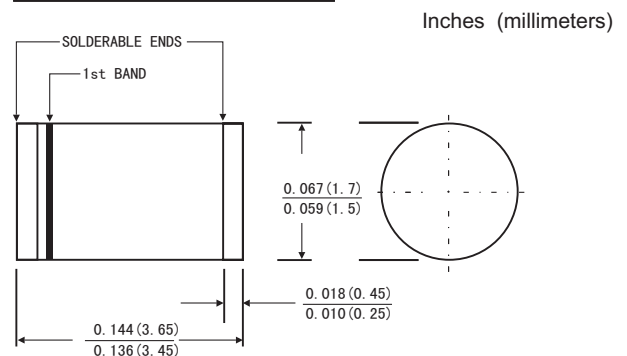

Features

- Bilateral Voltage triggered
- AC circuit oriented
- Glass-passivated junctions
- High surge current capabilities

Applications

- High voltage lamp ignitors
- Xenon ignitors
- Natural gas ignitors
- Over voltage protector
- Gas oil ignitors
- High voltage power supply
- Pulse generators
- Fluorescent lighting ignitors
- HID (high intensity discharge) lighting ignitors

SMA(DO-214AC)

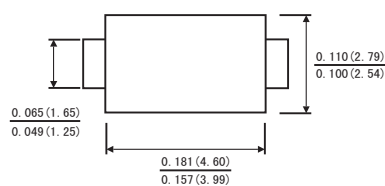

SOD-123FL

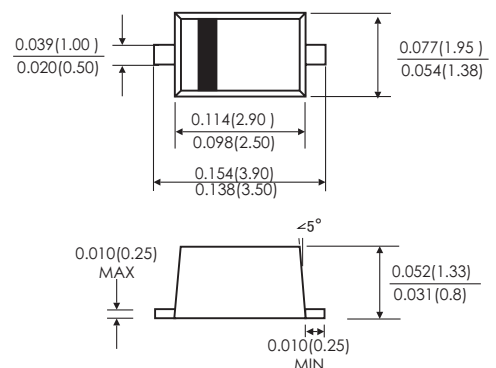

R-1

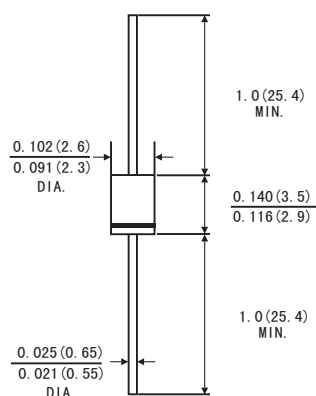

DO-41

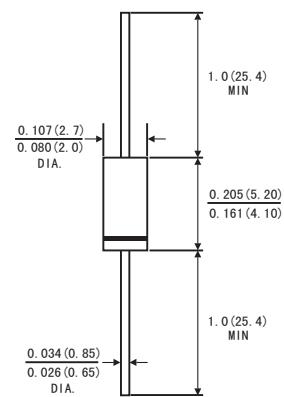

Electrical Specifications

PART NUMBER					IT(RMS)	VDRM	VBO		IDRM	IBO
DO-41	R-1	SMA	SOD-123FL	Mini-MELF	On-state RMS Current T _j ≤ 110°C 50/60Hz	Repetitive Peak Off-state Voltage	Breakover voltage 50/60Hz sine wave		Repetitive Peak Off-state Current 50/60Hz Sine Wave V=V _{DRM}	Breakover Current 50/60Hz sine wave
					Amps	Volts	Volts		μAmps	μAmps
					MAX	MIN	MIN	MAX	MAX	MAX
DB105A	DB105R	DB105S	DB105K	LL105	1.0	±90	95	113	5	10
DB110A	DB110R	DB110S	DB110K	LL110	1.0	±90	104	118	5	10
DB120A	DB120R	DB120S	DB120K	LL120	1.0	±90	110	125	5	10
DB130A	DB130R	DB130S	DB130K	LL130	1.0	±90	120	138	5	10
DB140A	DB140R	DB140S	DB140K	LL140	1.0	±90	130	146	5	10
DB150A	DB150R	DB150S	DB150K	LL150	1.0	±90	140	170	5	10
DB200A	DB200R	DB200S	DB200K	LL200	1.0	±180	190	215	5	10
DB220A	DB220R	DB220S	DB220K	LL220	1.0	±180	205	230	5	10
DB240A	DB240R	DB240S	DB240K	LL240	1.0	±190	220	250	5	10
DB250A	DB250R	DB250S	DB250K	LL250	1.0	±190	240	280	5	10
DB300A	DB300R	DB300S	DB300K	LL300	1.0	±190	270	330	5	10

I _H		V _{TM}	I _{TSM}		R _s	d _v /d _t	d _i /d _t
Dynamic Holding Current 50/60Hz Sine Wave R=100 OHMS mAmps		Peak On-state Voltage I _T =1Amp Volts MAX	Peak One Cycle Surge Current 50/60Hz Sine Wave (Non-Repetitive) Amps		Switching Resistance R _s = $\frac{(V_{BO}-V_S)}{(I_S-I_{BO})}$ 50/60Hz Sine Wave KΩ	Critical Rate-of-rise Of Off-state Voltage at Rate V _{DRM} T _j ≤ 100°C Volts/μsecond	Critical Rate-of-Rise Of On-State Current Amps/μsecond
TYP	MAX		60Hz	50Hz	MIN	MIN	TYP
40	100	2.0	20	16.7	0.1	1500	150
40	100	2.0	20	16.7	0.1	1500	150
40	100	2.0	20	16.7	0.1	1500	150
40	100	2.0	20	16.7	0.1	1500	150
40	100	2.0	20	16.7	0.1	1500	150
40	100	2.0	20	16.7	0.1	1500	150
40	100	2.0	20	16.7	0.1	1500	150
40	100	2.0	20	16.7	0.1	1500	150
40	100	2.0	20	16.7	0.1	1500	150
40	100	2.0	20	16.7	0.1	1500	150

Electrical Specifications

V-I Characteristics

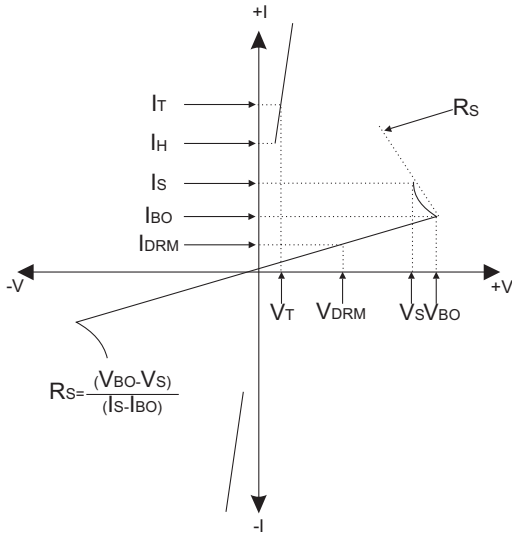

FIG.2 Peak surge current vs surge current duration

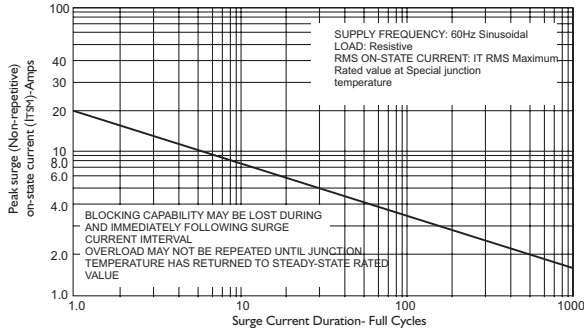

FIG.4 Repetitive Peak On-State Current (I_{TRM}) vs Pulse Width at Various Frequencies

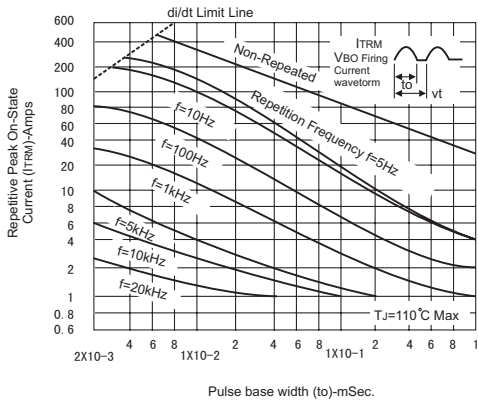

FIG.1 Normalized DC Holding Current vs case/Lead Temperature

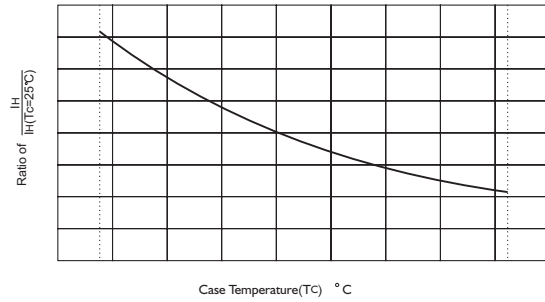

FIG.3 Normalized Repetitive Peak Breakover Current vs Junction Temperature

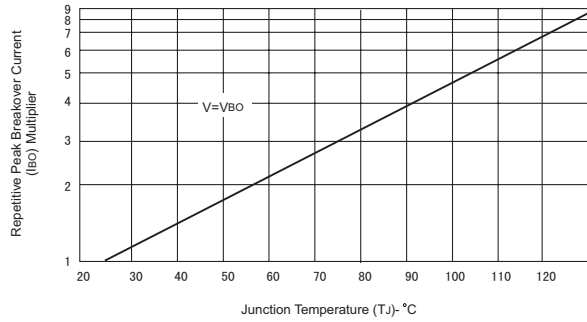
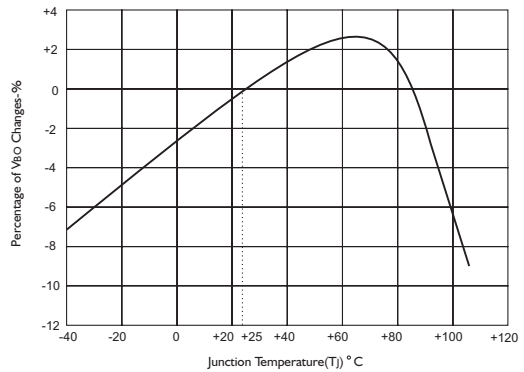

FIG.5 Normalized C_{BO} Changes vs Case Temperature



Electrical Specifications

FIG.6 Ignitor Circuit (Low Voltage Input)

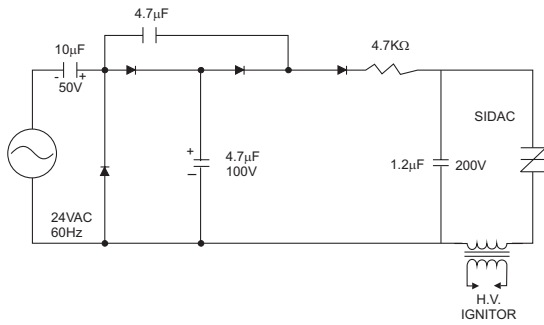

FIG.7 Typical High Pressure Sodium Lamp Firing Circuit

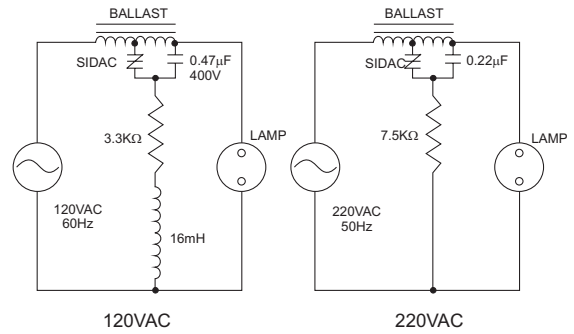

FIG.8 Comparison of SIDAC vs SCR

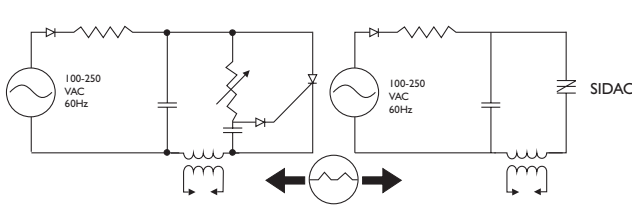

FIG.9 Xenon Lamp Flashing Circuit

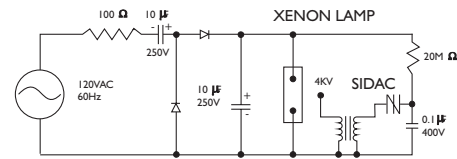

FIG.10 Dynamic Holding Current Test Circuit for SIDAC

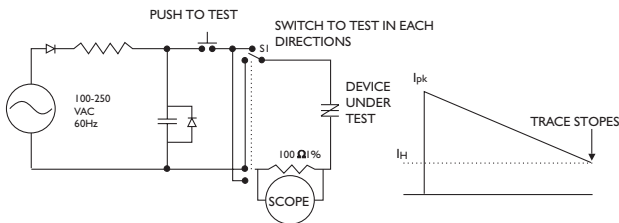
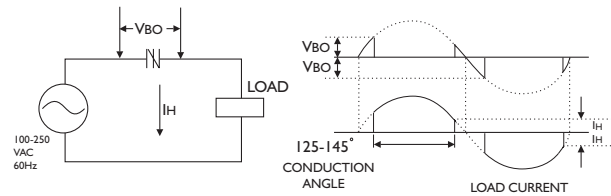

FIG.11 Basic SIDAC Circuit



Electrical Specifications

FIG.12 Relaxation Oscillator Using a SIDAC

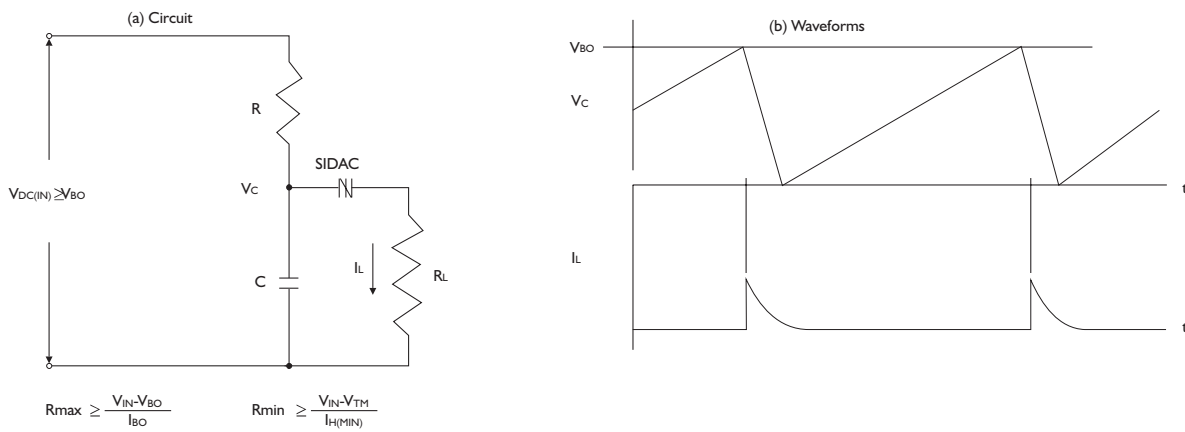
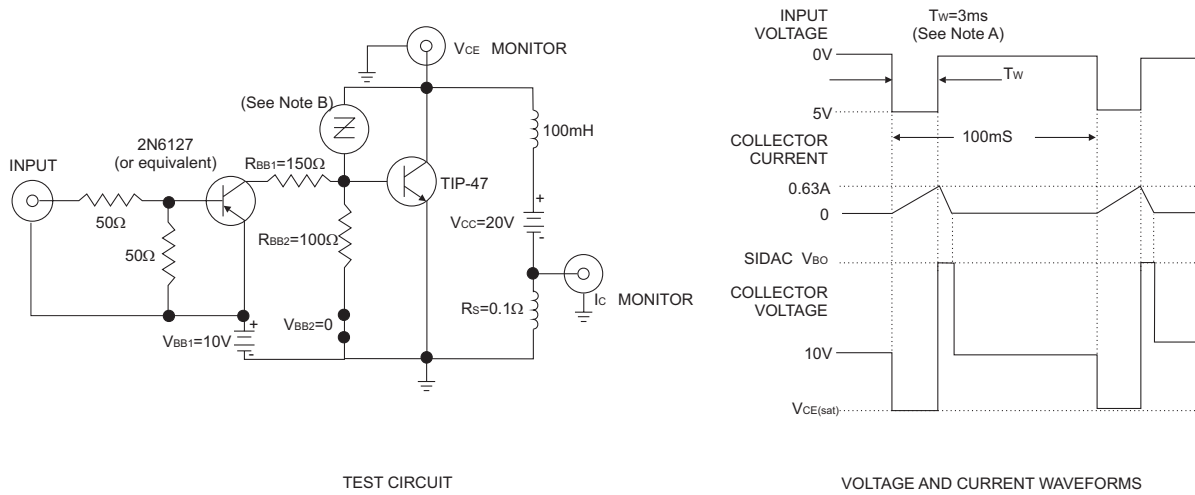

FIG.13 SIDAC Added To Protect Transistor For Typical Transistor Inductive Load Switching Requirements



NOTE A: Input pulse width is increased until $I_{CM}=0.63A$.

NOTE B: Sidac (or Diac or series of diacs) chosen so that V_{Bo} is just below V_{CE0} rating of transistor to be protected. The Sidac (or Diac) eliminates a reverse breakdown of the transistor in inductive switching circuits where otherwise the transistor could be destroyed.