

RoHS Compliant

ATA Flash Drive 255

Specifications

October 6th, 2011

Version 1.2



Apacer Technology Inc.

4th Fl., 75 Hsin Tai Wu Rd., Sec.1, Hsichih, New Taipei City, Taiwan 221

Tel: +886-2-2698-2888 Fax: +886-2-2698-2889

www.apacer.com

Features:

- **Standard ATA/IDE bus interface**
 - ATA command set compatible
 - ATA operating mode supports up to:
 - PIO Mode-4
 - Multiword DMA Mode-2
 - Ultra DMA Mode-6
- **Connector type**
 - 44-pin male
- **Power consumption (typical)***
 - Supply voltage: 5V±5%
 - Active mode: 687 mA
 - Idle mode: 52 mA
- **Estimated Performance***
 - Sustained read: Up to 120 MB/sec
 - Sustained write: Up to 105 MB/sec
- **Capacity**
 - 32, 64, 128, 256 GB
- **NAND Flash Type: SLC**
- **Temperature ranges**
 - Operation:
 - Standard: 0°C to 70°C
 - Extended Temperature: -40°C to 85°C
 - Storage: -40°C to 100°C
- **Flash management**
 - Intelligent endurance design
 - Advanced wear-leveling algorithms
 - S.M.A.R.T.
 - Built-in Hardware ECC
 - Enhanced Data Integrity
 - Intelligent power failure recovery
 - Enhanced security level
 - ATA Secure Erase
- **Cache on board**
- **RoHS compliant**

*Varies from capacities. The values presented in Performance and Power Consumption are typical and may vary depending on various settings and platforms.

Table of Contents

1. GENERAL DESCRIPTION	3
1.1 PERFORMANCE-OPTIMIZED CONTROLLER	3
1.1.1 SRAM Buffer	3
2. FUNCTIONAL BLOCK	4
3. PIN ASSIGNMENTS	5
4. CAPACITY SPECIFICATION	6
4.1 PERFORMANCE SPECIFICATIONS	6
4.2 ENVIRONMENTAL SPECIFICATIONS	6
5. FLASH MANAGEMENT	7
5.1 INTELLIGENT ENDURANCE DESIGN	7
5.1.1 Advanced wear-leveling algorithms	7
5.1.2 S.M.A.R.T.	7
5.1.3 Built-in Hardware ECC.....	7
5.1.4 Enhanced Data Integrity	7
5.2 INTELLIGENT POWER FAILURE RECOVERY.....	8
5.3 ENHANCED SECURITY LEVEL	8
5.3.1 ATA Secure Erase	8
6. SOFTWARE INTERFACE	9
6.1 COMMAND SET	9
7. ELECTRICAL SPECIFICATION.....	10
8. PHYSICAL CHARACTERISTICS	11
9. PRODUCT ORDERING INFORMATION	12
9.1 PRODUCT CODE DESIGNATIONS	12
9.2 VALID COMBINATIONS	13
9.2.1 Standard Temperature.....	13
9.2.2 Extended Temperature	13

1. General Description

Apacer's ATA-Flash Drive (AFD) is a high-performance, solid state drive (SSD) designed to replace a conventional IDE hard disk drive. AFD supports standard ATA/IDE protocol and can be plugged into a standard IDE connector commonly found in desktop or portable PCs. It is more rugged, reliable and power-efficient compared to the mechanical hard drive and is designed for use in rugged laptops, military devices, thin clients, Point of Sale (POS) terminals, telecom, medical instruments, surveillance systems and industrial PCs. AFD also offers users selectable Master/Slave operation through an external jumper setting. Apacer AFD Series is the best drop-in replacement for high-maintenance HDD where reliability is a major concern.

AFD includes a built-in microcontroller and file management firmware that communicates through with the ATA standard interfaces. This means the AFD does not require any additional or proprietary host software such as the Flash File System (FFS) and Memory Technology Driver (MTD) software. AFD is designed to work at 5 Volts, support the standard ATA/IDE protocol up to PIO Mode-4, Multiword DMA Mode-2, and Ultra DMA Mode-6 interfaces, and use a standard ATA driver that fits to all major operating systems such as Microsoft's Windows series, Apple's Mac OS family, and UNIX variants

Featuring technologies as Advanced Wear-leveling algorithms, S.M.A.R.T, Enhanced Data Integrity, Intelligent Power Failure Recovery, and ATA Secure Erase, with cache made of SDRAM up to 32 MB on board, Apacer assures users of a versatile device on data storage.

1.1 Performance-Optimized Controller

The heart of an ATA-Flash Drive is the ATA controller, which translates standard ATA signals into the data and controls of the flash media. This proprietary ATA controller is specifically designed to attain high data throughput from the host to the flash.

1.1.1 SRAM Buffer

The SRAM buffer is a key contributor to the ATA controller performance. It optimizes data writes to the flash.

2. Functional Block

The ATA-Flash Drive (AFD) includes the ATA controller and flash media, as well as the ATA standard interface. Figure 2-1 shows the functional block diagram.

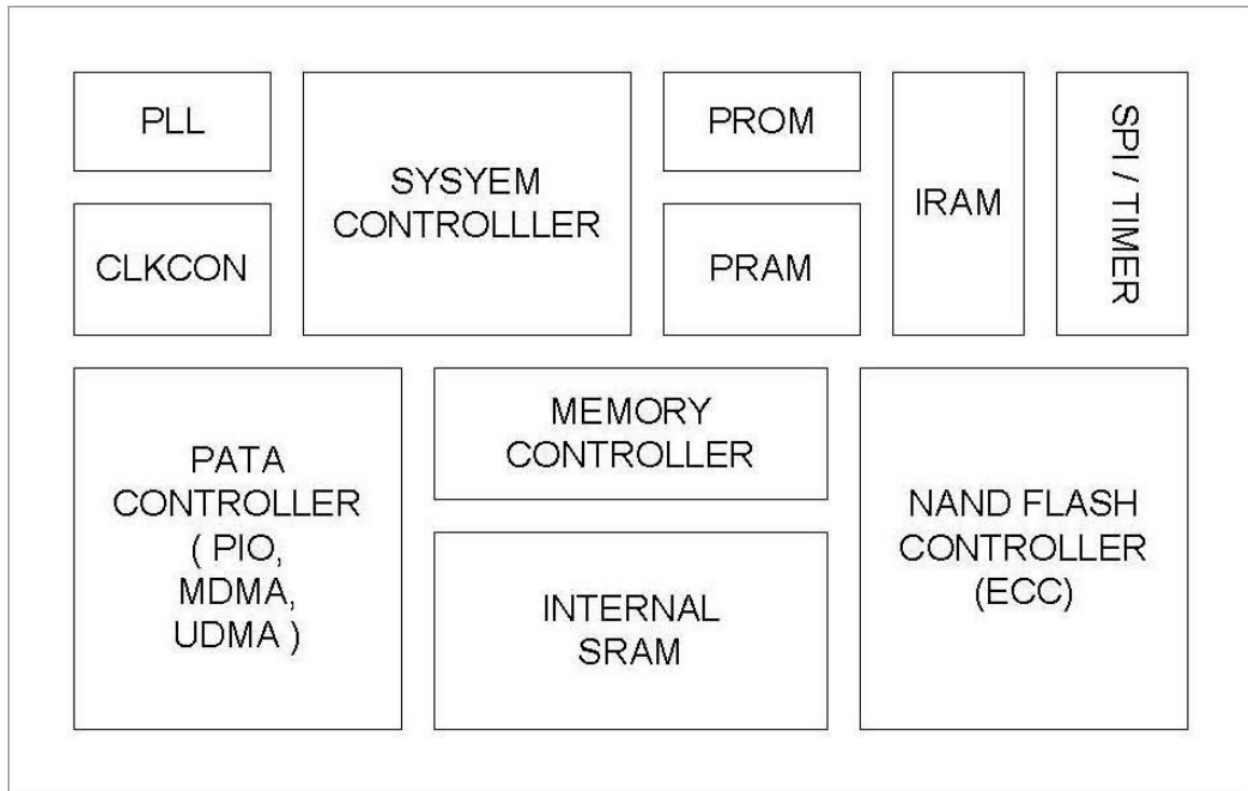

Figure 2-1: ATA-Flash Drive functional block diagram

3. Pin Assignments

Table 3-1 lists the pin assignments with respective signal names for the 44-pin configuration. A “#” suffix indicates the active low signal. The pin type can be input, output or input/output.

Figure 3-1: ATA-Flash Drive 44-pin Connector

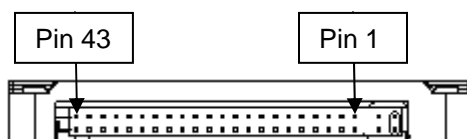

Table 3-1: Pin assignments for the 44-pin configuration

Pin No.	Signal Name	Pin Type	Pin No.	Signal Name	Pin Type
1	RESET#	I	2	GND	-
3	D7	I/O	4	D8	I/O
5	D6	I/O	6	D9	I/O
7	D5	I/O	8	D10	I/O
9	D4	I/O	10	D11	I/O
11	D3	I/O	12	D12	I/O
13	D2	I/O	14	D13	I/O
15	D1	I/O	16	D14	I/O
17	D0	I/O	18	D15	I/O
19	GND	-	20	NC	-
21	DMARQ	O	22	GND	-
23	IOWR#	I	24	GND	-
25	IORD# HDMARDY# HSTROBE#	I	26	GND	-
27	IORDY DDMARDY# DSTROBE	O	28	CSEL	I
29	DMACK#	I	30	GND	-
31	INTRQ	O	32	IOCS16#	O
33	A1	I	34	PDIAG#	I/O
35	A0	I	36	A2	I
37	CS1FX#	I	38	CS3FX#	I
39	DASP#	I/O	40	GND	-
41	VDD	-	42	VDD	-
43	GND	-	44	NC	-

4. Capacity Specification

Capacity specification of the ATA-Flash Drive (AFD) product family is available as shown in Table 4-1. It lists the specific capacity and the default numbers of heads, sectors and cylinders for each product line.

Table 4-1: AFD capacity specifications

Capacity	Total bytes*	Cylinders**	Heads	Sectors	Max LBA
32 GB	30,064,771,072	16383	16	63	58,720,256
64 GB	60,129,542,144	16383	16	63	117,440,512
128 GB	120,259,084,288	16383	16	63	234,881,024
256 GB	240,518,168,576	16383	16	63	469,762,048

*Display of total bytes varies from file systems.

**Cylinders, heads or sectors are not applicable for these capacities. Only LBA addressing applies.

4.1 Performance Specifications

Performance of the ATA-Flash Drive is listed in Table 4-2.

Table 4-2: Performance specifications

Capacity	32 GB	64 GB	128 GB	256 GB
Performance				
Sustained read (MB/s)	120	120	115	115
Sustained write (MB/s)	105	105	95	95

Note: Performance varies from flash configurations.

4.2 Environmental Specifications

Environmental specification of the ATA-Flash Drive, which follows the standards of MIL-STD-810F, MIL-STD-810G, & MIL-STD-202G, is available as shown in Table 4-3.

Table 4-3: ATA-Flash Drive environmental specifications

Item	Criteria
Non-Operating Temperature	40~100(°C)
Operating Temperature	STD*: 0~70(°C) ET**: -40~85(°C)
Sine Vibration(Non-Op)	10~2000(Hz)/15(G)
Random Vibration(Op)	20~2000(Hz)/7.7(Grms)
Shock	Op : 50(G)/11(ms) Non-Op : 1500(G)/0.5(ms)
Humidity	5~95% R.H

*Standard

**Extended Temperature

5. Flash Management

5.1 Intelligent Endurance Design

5.1.1 Advanced wear-leveling algorithms

The NAND flash devices are limited by a certain number of write cycles. When using a file system, frequent file table updates is mandatory. If some area on the flash wears out faster than others, it would significantly reduce the lifetime of the whole device, even if the erase counts of others are far from the write cycle limit. Thus, if the write cycles can be distributed evenly across the media, the lifetime of the media can be prolonged significantly. The scheme is achieved both via buffer management and Apacer-specific advanced wear leveling to ensure that the lifetime of the flash media can be increased, and the disk access performance is optimized as well.

5.1.2 S.M.A.R.T.

S.M.A.R.T. is an acronym for Self-Monitoring, Analysis and Reporting Technology, an open standard allowing disk drives to automatically monitor their own health and report potential problems. It protects the user from unscheduled downtime by monitoring and storing critical drive performance and calibration parameters. Ideally, this should allow taking proactive actions to prevent impending drive failure. Apacer SMART feature adopts the standard SMART command B0h to read data from the drive. When the Apacer SMART Utility running on the host, it analyzes and reports the disk status to the host before the device is in critical condition.

5.1.3 Built-in Hardware ECC

The ATA-Flash Drive uses BCH Error Detection Code (EDC) and Error Correction Code (ECC) algorithms which correct up to configurable 18, 16, 15, 14, 8, 7, 6 bits of random errors for each 512-byte block of data. High performance is fulfilled through hardware-based error detection and correction.

5.1.4 Enhanced Data Integrity

The properties of NAND flash memory make it ideal for applications that require high integrity while operating in challenging environments. The integrity of data to NAND flash memory is generally maintained through ECC algorithms and bad block management. Flash controllers can support up to 8 bits ECC capability for accuracy of data transactions, and bad block management is a preventive mechanism from loss of data by retiring unusable media blocks and relocating the data to the other blocks, along with the integration of advanced wear leveling algorithms, so that the lifespan of device can be expanded.

5.2 Intelligent Power Failure Recovery

The Low Power Detection on the controller initiates cached data saving before the power supply to the device is too low. This feature prevents the device from crash and ensures data integrity during an unexpected blackout. Once power was failure before cached data writing back into flash, data in the cache will lost. The next time the power is on, the controller will check these fragmented data segment, and, if necessary, replace them with old data kept in flash until programmed successfully.

5.3 Enhanced Security Level

5.3.1 ATA Secure Erase

Accomplished by the Secure Erase (SE) command, which added to the open ANSI standards that control disk drives, “ATA Secure Erase” is built into the disk drive itself and thus far less susceptible to malicious software attacks than external software utilities. It is a positive easy-to-use data destroy command, amounting to electronic data shredding. Executing the command causes a drive to internally completely erase all possible user data. This command is carried out within disk drives, so no additional software is required. Once executed, neither data nor the erase counter on the device would be recoverable, which blurs the accuracy of device lifespan. The process to erase will not be stopped until finished while encountering power failure, and will be continued when power is back on.

6. Software Interface

6.1 Command Set

This section defines the software requirements and the format of the commands the host sends to the ATA-Flash Drive (AFD). Commands are issued to the AFD by loading the required registers in the command block with the supplied parameters, and then writing the command code to the command register. The manner in which a command is accepted varies.

Table 6-1: Command set

Code	Command	Code	Command
E5h	Check Power Mode	F6h	Security Disable Password
92h	Download Microcode	F3h	Security Erase Prepare
90h	Execute Device Diagnostic	F4h	Security Erase Unit
E7h	Flush Cache	F5h	Security Freeze Lock
EAh	Flush Cache EXT	F1h	Security Set Password
ECh	Identify Device	F2h	Security Unlock
A1h	Identify Packet Device	70h	Seek
E3h	Idle	EFh	Set Features
E1h	Idle Immediate	F9h	Set Max
91h	Initialize Device Parameters	91h	Set Max Address EXT
00h	NOP	C6h	Set Multiple Mode
E4h	Read Buffer	E6h	Sleep
C8h	Read DMA	B0h	SMART
25h	Read DMA EXT	E2h	Standby
C4h	Read Multiple	E0h	Standby Immediate
29h	Read Multiple EXT	E8h	Write Buffer
F8h	Read Native Max Address	CAh	Write DMA
27h	Read Native Max Address EXT	35h	Write DMA EXT
20h	Read Sector	C5h	Write Multiple
24h	Read Sector EXT	39h	Write Multiple EXT
40h	Read Verify Sectors	30h	Write Sector
42h	Read Verify Sectors EXT	34h	Write Sector EXT
10h	Recalibrate		

7. Electrical Specification

Caution: Absolute Maximum Stress Ratings – Applied conditions greater than those listed under “Absolute Maximum Stress Ratings” may cause permanent damage to the device. This is a stress rating only and functional operation of the device at these conditions or conditions greater than those defined in the operational sections of this data sheet is not implied. Exposure to absolute maximum stress rating conditions may affect device reliability.

Table 7-1: ATA-Flash Drive operating voltage

Range	Ambient Temperature	5V±5%
Standard	0°C to +70°C	4.75-5.25V
Extended Temperature	-40°C to +85°C	

Table 7-2: Absolute maximum power pin stress ratings

Parameter	Symbol	Conditions
Input Power	V _{DD}	-0.3V min. to 6.5V max.
Voltage on any pin except V _{DD} with respect to GND	V	-0.5V min. to V _{DD} + 0.5V max.

8. Physical Characteristics

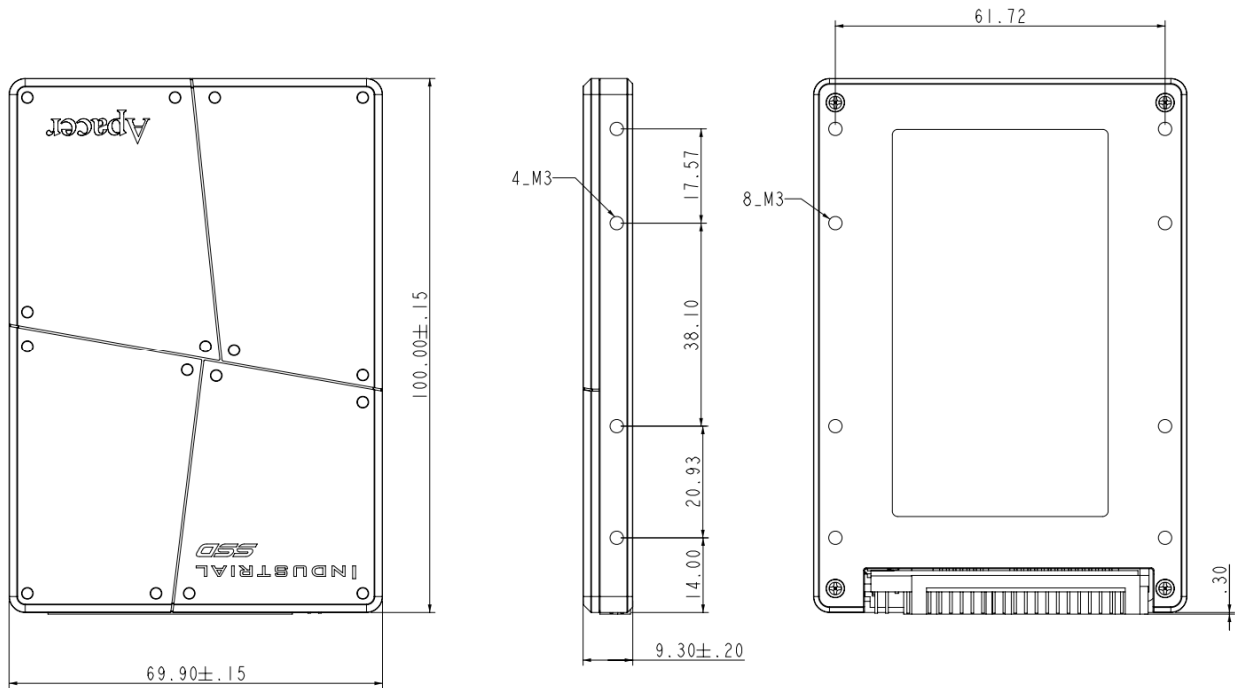

Unit: mm
Tolerance: ± 0.2

9. Product Ordering Information

9.1 Product Code Designations

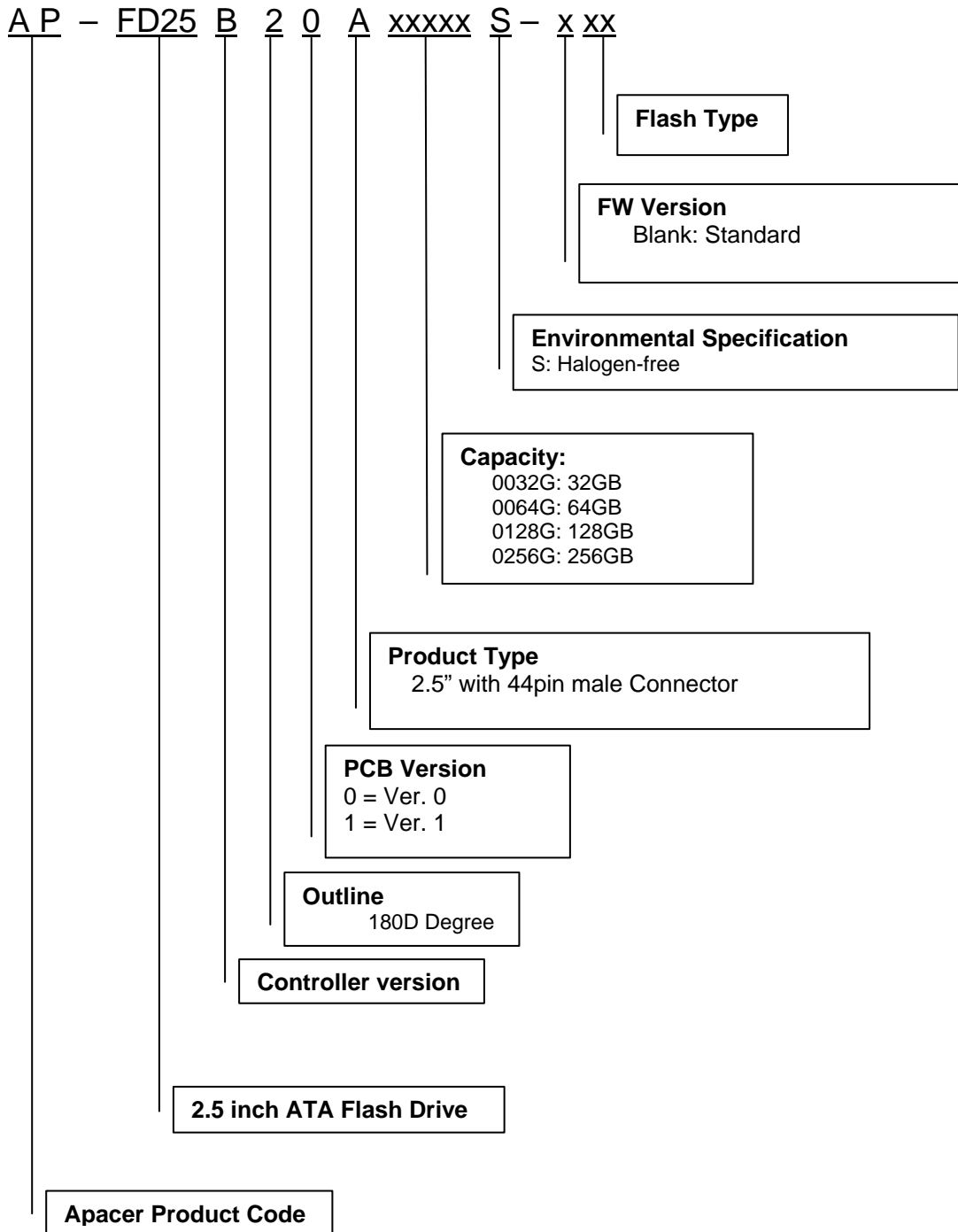

9.2 Valid Combinations

9.2.1 Standard Temperature

Capacity	Model Number
32GB	AP-FD25B20A0032GS-T
64GB	AP-FD25B20A0064GS-T
128GB	AP-FD25B20A0128GS-1C
256GB	AP-FD25B20A0256GS-1C

9.2.2 Extended Temperature

Capacity	Model Number
32 GB	AP-FD25B20A0032GS-ET
64 GB	AP-FD25B20A0064GS-ET
128GB	AP-FD25B20A0128GS-E1C
256GB	AP-FD25B20A0256GS-E1C

Revision History

Revision	Date	Description	Remark
0.1	10/29/2010	Preliminary	
0.2	12/03/2010	Updated drawings & product ordering information	
0.3	12/07/2010	Updated drawings & environmental specifications	
0.4	12/31/2010	Adjusted product capacity & flash mgmt. details	
0.5	01/07/2011	Context refined	
1.0	02/21/2011	Official release	
1.1	03/03/2011	Updated environmental specification	
1.2	10/06/2011	-- Added 128GB and 256GB capacities -- Updates for hardware	

Global Presence

Taiwan (Headquarters)	Apacer Technology Inc. 4 th Fl., 75 Hsin Tai Wu Rd., Sec.1 Hsichih, New Taipei City Taiwan 221 R.O.C. Tel: +886-2-2698-2888 Fax: +886-2-2698-2889 amtsales@apacer.com
U.S.A.	Apacer Memory America, Inc. 386 Fairview Way, Suite102, Milpitas, CA 95035 Tel: 1-408-518-8699 Fax: 1-408-935-9611 sa@apacerus.com
Japan	Apacer Technology Corp. 5F, Matsura Bldg., Shiba, Minato-Ku Tokyo, 105-0014, Japan Tel: 81-3-5419-2668 Fax: 81-3-5419-0018 jpservices@apacer.com
Europe	Apacer Technology B.V. Aziëlaan 2, 5232 BA 's-Hertogenbosch, The Netherlands Tel: 31-73-645-9620 Fax: 31-73-645-9629 sales@apacer.nl
China	Apacer Electronic (Shanghai) Co., Ltd 1301, No.251, Xiaomujiao Road, Shanghai, 200032, China Tel: 86-21-5529-0222 Fax: 86-21-5206-6939 sales@apacer.com.cn
India	Apacer Technologies Pvt Ltd, #1064, 1st Floor, 7th 'A' Main, 3rd Block Koramangala, Bangalore – 560 034 Tel: +91 80 4152 9061/62/63 Fax: +91 80 4170 0215 sales_india@apacer.com

Mouser Electronics

Authorized Distributor

Click to View Pricing, Inventory, Delivery & Lifecycle Information:

[Apacer:](#)

[AP-FD25B20A0128GS-1C](#) [AP-FD25B20A0256GS-1C](#)