

isc Silicon NPN Power Transistor

MJE18004

DESCRIPTION

- Collector-Base Breakdown Voltage-
: $V_{(BR)CBO} = 1000V(\text{Min})$
- High Switching Speed

APPLICATIONS

- Designed for use in 220V line-operated switchmode power supplies and electronic light ballasts

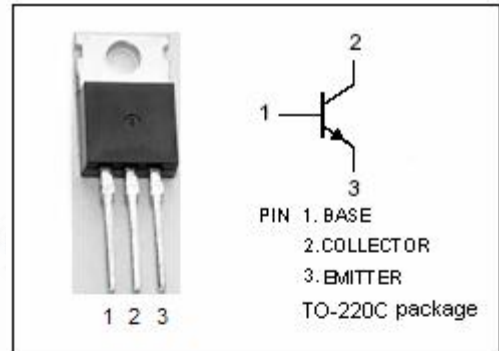

ABSOLUTE MAXIMUM RATINGS($T_a=25^\circ\text{C}$)

SYMBOL	PARAMETER	VALUE	UNIT
V_{CBO}	Collector-Base Voltage	1000	V
V_{CEO}	Collector-Emitter Voltage	450	V
V_{EBO}	Emitter-Base Voltage	9	V
I_C	Collector Current-Continuous	5	A
I_{CM}	Collector Current-Peak	10	A
I_B	Base Current	2	A
I_{BM}	Base Current-Peak	4	A
P_D	Total Power Dissipation@ $T_c=25^\circ\text{C}$	100	W
T_j	Junction Temperature	150	$^\circ\text{C}$
T_{stg}	Storage Temperature	-65~150	$^\circ\text{C}$

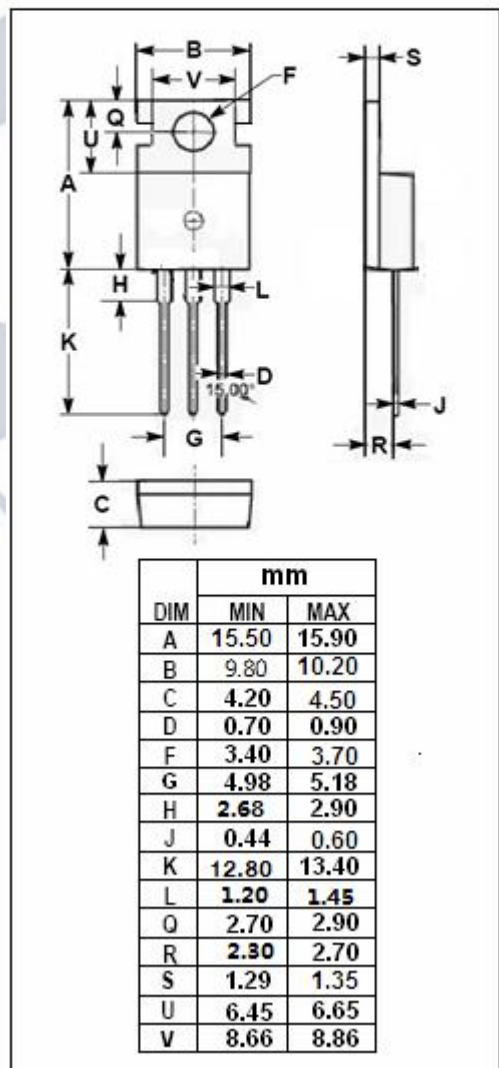

THERMAL CHARACTERISTICS

SYMBOL	PARAMETER	MAX	UNIT
$R_{th\ j-c}$	Thermal Resistance, Junction to Case	1.25	$^\circ\text{C/W}$
$R_{th\ j-a}$	Thermal Resistance, Junction to Ambient	62.5	$^\circ\text{C/W}$

isc Silicon NPN Power Transistor

MJE18004

ELECTRICAL CHARACTERISTICS

T_j=25°C unless otherwise specified

SYMBOL	PARAMETER	CONDITIONS	MIN	TYP	MAX	UNIT
V _{CEO(SUS)}	Collector-Emitter Sustaining Voltage	I _C = 30mA; I _B =0	450			V
V _{CE(sat)-1}	Collector-Emitter Saturation Voltage	I _C = 1 A ; I _B = 0.1A T _C =125°C			0.5 0.6	V
V _{CE(sat)-2}	Collector-Emitter Saturation Voltage	I _C = 2A ; I _B = 0.4 A T _C =125°C			0.45 0.8	V
V _{CE(sat)-3}	Collector-Emitter Saturation Voltage	I _C = 2.5A ; I _B = 0.5 A			0.75	V
V _{BE(sat)-1}	Base-Emitter Saturation Voltage	I _C = 1A; I _B = 0.1A			1.1	V
V _{BE(sat)-2}	Base-Emitter Saturation Voltage	I _C = 2A; I _B = 0.4A			1.25	V
V _{BE(sat)-3}	Base-Emitter Saturation Voltage	I _C = 2.5A; I _B = 0.5 A			1.3	V
I _{CES}	Collector Cutoff Current	V _{CE} = Rated V _{CE} ; V _{EB} = 0 T _C =125°C			0.05 0.5	mA
		V _{CE} = 800V T _C =125°C			0.01 0.1	
I _{CEO}	Collector Cutoff Current	V _{CE} = Rated V _{CE} ; I _B = 0			0.1	mA
I _{EBO}	Emitter Cutoff Current	V _{EB} = 9V; I _C = 0			0.1	mA
h _{FE-1}	DC Current Gain	I _C = 1A ; V _{CE} = 5V	14		36	
h _{FE-2}	DC Current Gain	I _C = 2A ; V _{CE} = 1V	6			
h _{FE-3}	DC Current Gain	I _C = 10mA; V _{CE} = 5V	10			
f _T	Current-Gain—Bandwidth Product	I _C = 0.5A; V _{CE} = 10V; f _{test} =1.0MHz		13		MHz
C _{OB}	Output Capacitance	I _E = 0; V _{CB} = 10V; f _{test} =1.0MHz		450		pF

Switching Times Resistive Load, Duty Cycle ≤ 10%, Pulse Width = 20 μs

t _{on}	Turn-on Time	V _{CC} =250V , I _C =2.5A I _{B1} =I _{B2} =0.5 A		450	600	ns
t _S	Storage Time			2	3	μs
t _f	Turn-off Time			0.275	0.4	μs