

CGA4J3X7R1E155M125AB

TDK Item Description : CGA4J3X7R1E155MT****



Equivalent C2012X7R1E155M for Automotive

Application & Main Feature

Automotive Grade (General (Up to 50V))

Series

CGA4(2012) [EIA CC0805]

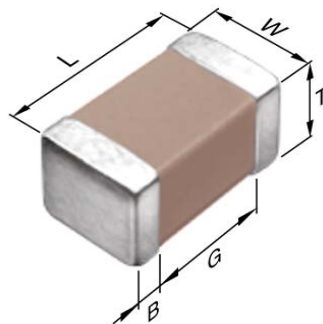

Dimensions

- L 2.00mm +/-0.2mm
- W 1.25mm +/-0.2mm
- T 1.25mm +/-0.2mm
- B 0.20mm Min.
- G 0.50mm Min.

Temperature Characteristic

X7R (-55 to 125 degC +/-15%)

Rated Voltage

1E (25Vdc)

Capacitance

1.5uF

Capacitance Tolerance

M (+/-20%)

Dissipation Factor

5% Max.

Insulation Resistance

333Mohm Min.

AEC-Q200

Yes

|Z|, ESR vs. Freq. Characteristics

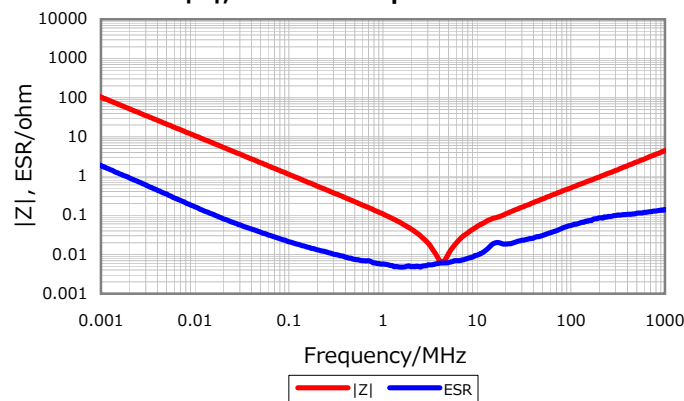

Cap. vs. Freq. Characteristic

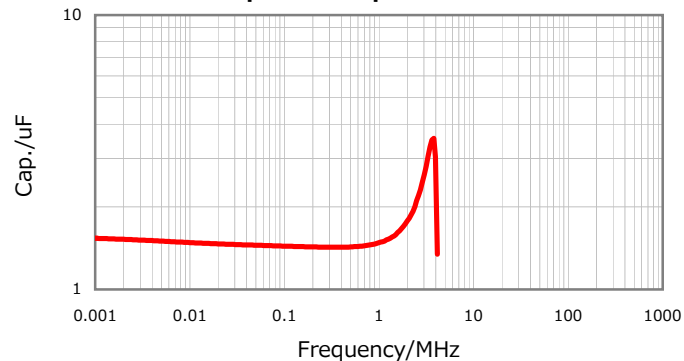

DC Bias Characteristic

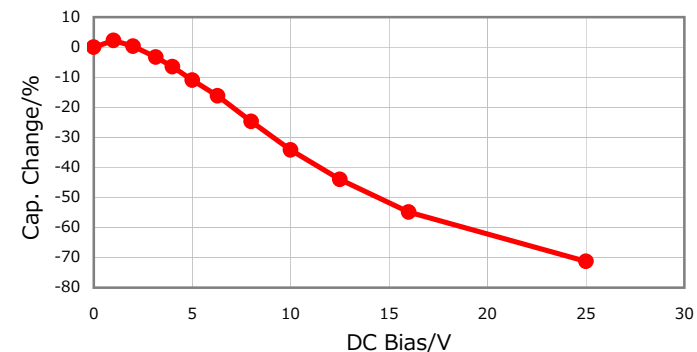

Temperature Characteristics

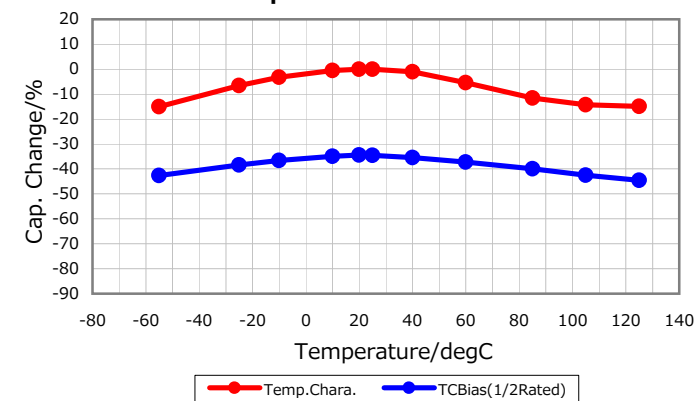

Ripple Temperature Rise Characteristics

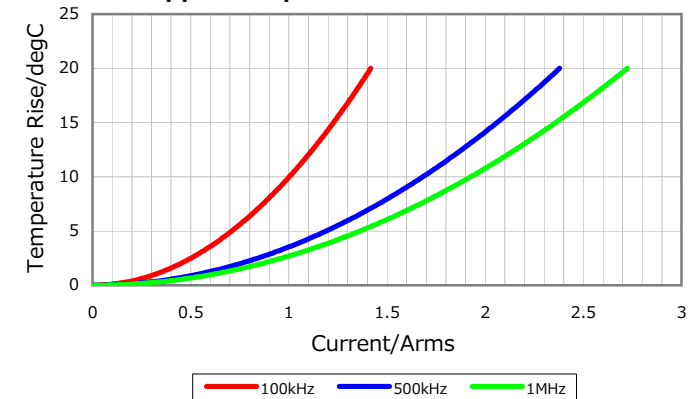

Characterization Sheet (Multilayer Ceramic Chip Capacitors)



All specifications are subject to change without notice.

January 4, 2016