

CZRL55C2V4-G Thru CZRL55C75-G

Voltage: 2.4 to 75 Volts

Power: 500 mWatts

RoHS Device



Features

- Silicon epitaxial power Zener diodes.
- For use as low voltage stabilizer or voltage reference.
- The Zener voltages are graded according to the international E24 standard. Higher Zener voltages and 1% tolerance available on request.
- Pb free product.

Mechanical data

- Case: MiniMELF glass case (SOD-80).
- Polarity: Color band denotes cathode end.
- Mounting position: Any.
- Approx. Weight: 0.05g.

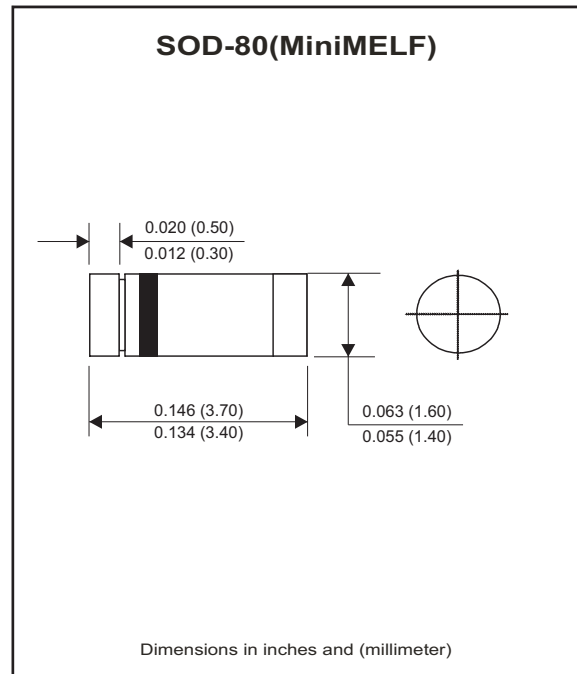

Circuit diagram



Maximum Rating And Electrical Characteristics

(TA=25°C, unless otherwise noted)

Parameter	Test Conditions	Symbol	Value	Unit
Maximum power dissipation	R _{θJA} ≤ 300K/W	P _V	500	mW
Z-current		I _Z	P _V /V _Z	mA
Junction temperature		T _J	175	°C
Storage temperature range		T _{STG}	-65 ~ +175	°C
Maximum thermal resistance	On PC board 50×50×1.6mm	R _{θJA}	500	°C/W
Forward voltage	I _F =200mA	V _F	1.5	V

ELECTRICAL CHARACTERISTICS(T_A = 25°C)

Part No.	Nominal Zener Voltage			Max. Zener Impedence				Max. Reverse Leakage Current		Typ. Temp. Coefficient
	V _Z @ I _{ZT}			Z _{ZT} @ I _{ZT}		Z _{ZK} @ I _{ZK}		I _R @ V _R		V _Z %/K
	Nom.	Min.	Max.	ohm	mA	ohm	mA	uA	V	
CZRL55C2V4-G	2.4	2.28	2.56	85	5.0	600	1.0	50.0	1.0	-0.09~-0.06
CZRL55C2V7-G	2.7	2.50	2.90	85	5.0	600	1.0	10.0	1.0	-0.09~-0.06
CZRL55C3V0-G	3.0	2.80	3.20	90	5.0	600	1.0	4.0	1.0	-0.08~-0.05
CZRL55C3V3-G	3.3	3.10	3.50	90	5.0	600	1.0	2.0	1.0	-0.08~-0.05
CZRL55C3V6-G	3.6	3.40	3.80	90	5.0	600	1.0	2.0	1.0	-0.08~-0.05
CZRL55C3V9-G	3.9	3.70	4.10	90	5.0	600	1.0	2.0	1.0	-0.08~-0.05
CZRL55C4V3-G	4.3	4.00	4.60	90	5.0	600	1.0	1.0	1.0	-0.06~-0.03
CZRL55C4V7-G	4.7	4.40	5.00	80	5.0	600	1.0	0.5	1.0	-0.05~+0.02
CZRL55C5V1-G	5.1	4.80	5.40	60	5.0	550	1.0	0.1	1.0	-0.02~+0.02
CZRL55C5V6-G	5.6	5.20	6.00	40	5.0	450	1.0	0.1	1.0	-0.05~+0.05
CZRL55C6V2-G	6.2	5.80	6.60	10	5.0	200	1.0	0.1	2.0	0.03~0.06
CZRL55C6V8-G	6.8	6.40	7.20	8	5.0	150	1.0	0.1	3.0	0.03~0.07
CZRL55C7V5-G	7.5	7.00	7.90	7	5.0	50	1.0	0.1	5.0	0.03~0.07
CZRL55C8V2-G	8.2	7.70	8.70	7	5.0	50	1.0	0.1	6.2	0.03~0.08
CZRL55C9V1-G	9.1	8.50	9.60	10	5.0	50	1.0	0.1	6.8	0.03~0.09
CZRL55C10-G	10.0	9.40	10.60	15	5.0	70	1.0	0.1	7.5	0.03~0.1
CZRL55C11-G	11.0	10.40	11.60	20	5.0	70	1.0	0.1	8.2	0.03~0.11
CZRL55C12-G	12.0	11.40	12.70	20	5.0	90	1.0	0.1	9.1	0.03~0.11
CZRL55C13-G	13.0	12.40	14.10	26	5.0	110	1.0	0.1	10	0.03~0.11
CZRL55C15-G	15.0	13.80	15.60	30	5.0	110	1.0	0.1	11	0.03~0.11
CZRL55C16-G	16.0	15.30	17.10	40	5.0	170	1.0	0.1	12	0.03~0.11
CZRL55C18-G	18.0	16.80	19.10	50	5.0	170	1.0	0.1	13	0.03~0.11
CZRL55C20-G	20.0	18.80	21.20	55	5.0	220	1.0	0.1	15	0.03~0.11
CZRL55C22-G	22.0	20.80	23.30	55	5.0	220	1.0	0.1	16	0.04~0.12
CZRL55C24-G	24.0	22.80	25.60	80	5.0	220	1.0	0.1	18	0.04~0.12
CZRL55C27-G	27.0	25.10	28.90	80	5.0	220	1.0	0.1	20	0.04~0.12
CZRL55C30-G	30.0	28.00	32.00	80	5.0	220	1.0	0.1	22	0.04~0.12
CZRL55C33-G	33.0	31.00	35.00	80	5.0	220	1.0	0.1	24	0.04~0.12
CZRL55C36-G	36.0	34.00	38.00	80	5.0	220	1.0	0.1	27	0.04~0.12
CZRL55C39-G	39.0	37.00	41.00	90	2.5	500	0.5	0.1	30	0.04~0.12
CZRL55C43-G	43.0	40.00	46.00	90	2.5	600	0.5	0.1	33	0.04~0.12
CZRL55C47-G	47.0	44.00	50.00	110	2.5	700	0.5	0.1	36	0.04~0.12
CZRL55C51-G	51.0	48.00	54.00	125.0	2.5	1000	0.5	0.1	39	0.04~0.12
CZRL55C56-G	56.0	52.00	60.00	135.0	2.5	1000	0.5	0.1	43	0.04~0.12
CZRL55C62-G	62.0	58.00	66.00	150.0	2.5	1000	0.5	0.1	47	0.04~0.12
CZRL55C68-G	68.0	64.00	72.00	200.0	2.5	1000	0.5	0.1	51	0.04~0.12
CZRL55C75-G	75.0	70.00	79.00	200.0	2.5	1500	0.5	0.1	56	0.04~0.12

RATING AND CHARACTERISTIC CURVES (CZRL55C2V4-G Thru CZRL55C75-G)

Fig.1-Total Power Dissipation vs. Ambient Temperature

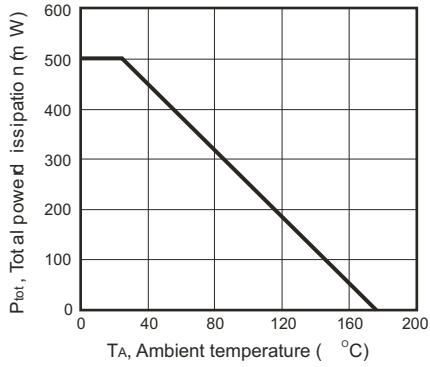

Fig.2-Typical Change of Working Voltage Under Operating Condition at T_A=25 °C

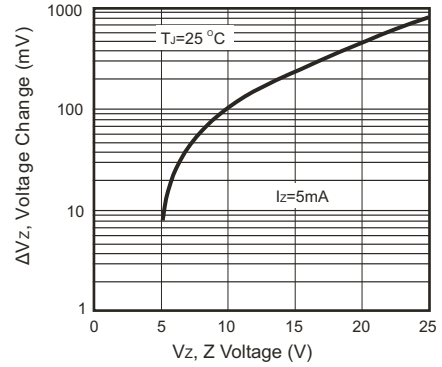

Fig.3-Typical Change of Working Voltage vs. Junction Temperature

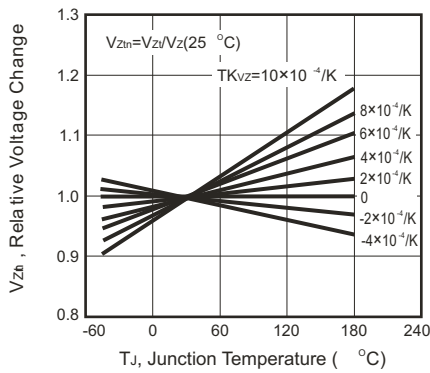

Fig.4-Temperature Coefficient of V_Z vs. Z-Voltage

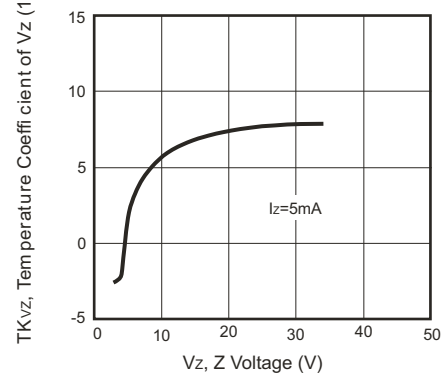
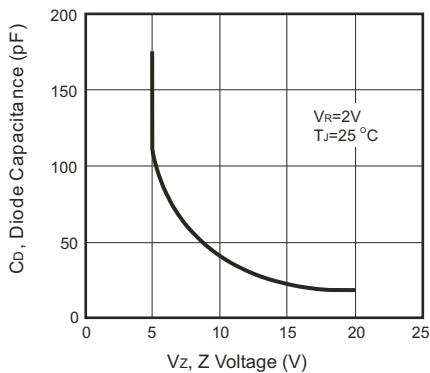

Fig.5-Diode Capacitance vs. Z-Voltage



RATING AND CHARACTERISTIC CURVES (CZRL55C2V4-G Thru CZRL55C75-G)

Fig.6-Forward Current vs. Forward Voltage

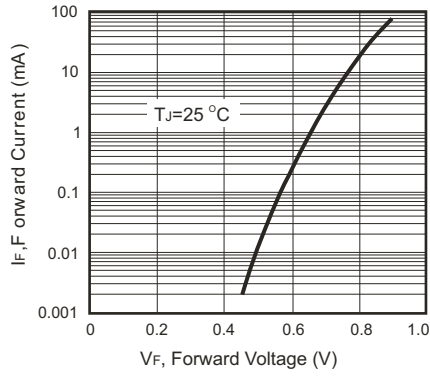

Fig.7-Z Current vs. Z Voltage

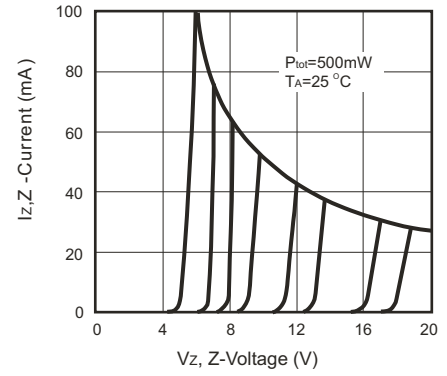

Fig.8-Z Current vs. Z Voltage

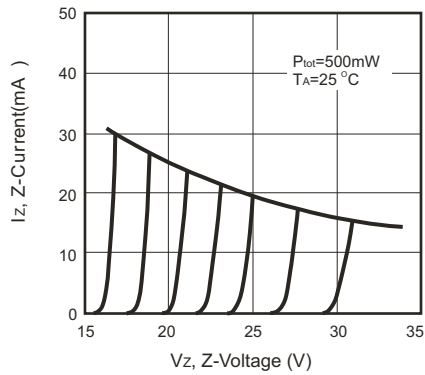
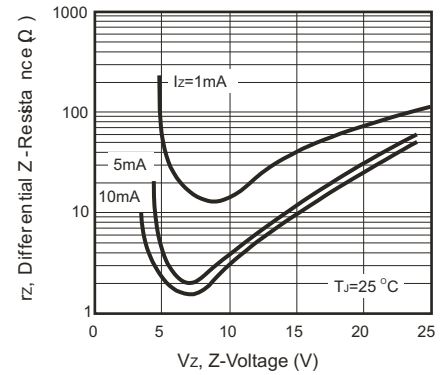
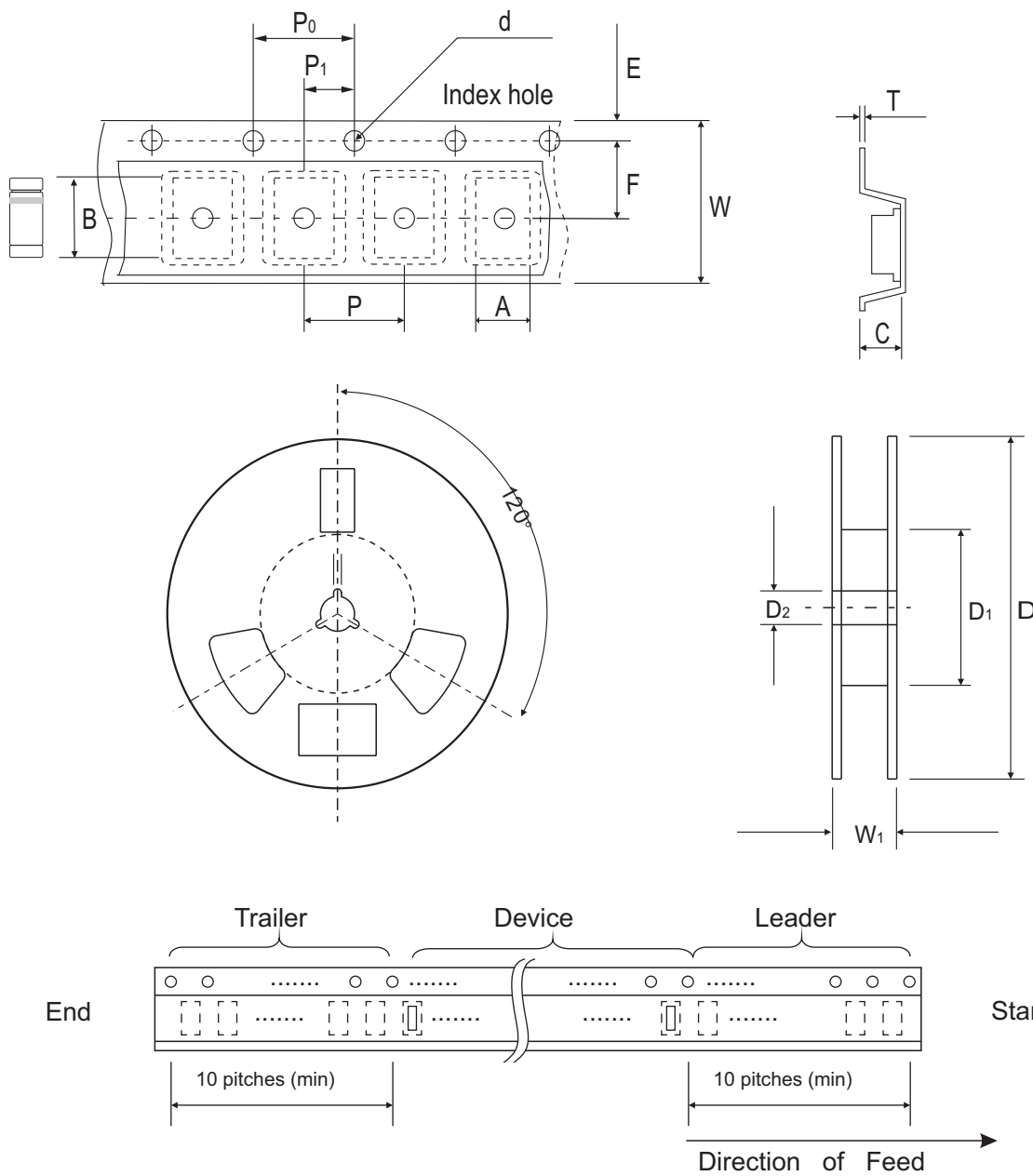

Fig.9-Differential Z-Resistance vs. Z-Voltage



Reel Taping Specification



Mini-MELF (SOD-80)	SYMBOL	A	B	C	d	D	D1	D2
	(mm)	2.0 (max)	3.9 (max)	2.0 (max)	1.55 ± 0.10	178 ± 1.00	50.0 MIN.	13.0 ± 0.20
	(inch)	0.078(max)	0.153 (max)	0.078 (max)	0.061 ± 0.004	7.00 ± 0.039	1.969 MIN.	0.512 ± 0.008

Mini-MELF (SOD-80)	SYMBOL	E	F	P	P0	P1	W	W1
	(mm)	1.75 ± 0.10	3.50 ± 0.05	4.00 ± 0.10	4.00 ± 0.10	2.00 ± 0.05	8.00 ± 0.30	14.4 MAX.
	(inch)	0.069 ± 0.004	0.138 ± 0.002	0.157 ± 0.004	0.157 ± 0.004	0.079 ± 0.002	0.314 ± 0.012	0.567 MAX

Suggested PAD Layout

SIZE	Mini-MELF (SOD-80)	
	(mm)	(inch)
A	3.40	0.134
B	1.30	0.051
C	1.70	0.067
D	5.10	0.201
E	1.70	0.067

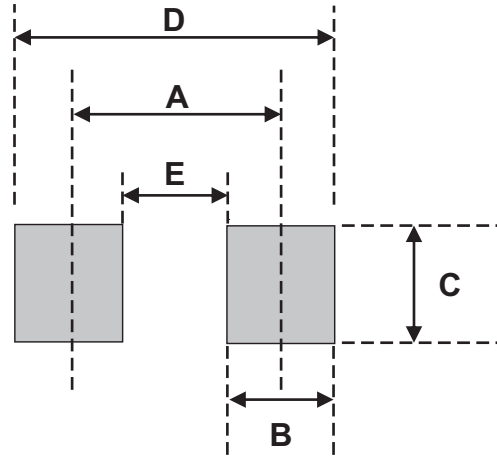

Standard Packaging

Case Type	REEL PACK	
	REEL (pcs)	Reel Size (inch)
Mini MELF (SOD-80)	2,500	7