

SERIAL COMMUNICATIONS CONTROLLER

Thank you for your interest in the SCC, one of the most versatile and most popular Serial Data Communications ICs. This document is intended to provide answers to all technical questions about the Z8530 Serial Communications Controller. Please read this Preface where we try to anticipate your questions.

- If you are new to serial data communications, you will need additional tutorial information. Of the many introductory texts on this subject, *Technical Aspects of Data Communications* by John E. McNamara, published by Digital Press (DEC) 1982, is one of the best.
- If you have designed with simpler UARTs and USARTs, and HDLC/SDLC devices, the SCC offers you far greater flexibility, but also requires an in-depth study and understanding of the impact and the use of its many powerful features. This manual contains important information.
- If you are familiar with the Z80-SIO, you will feel right at home with the SCC, for it is really a functionally enhanced superset of the Z80-SIO.

Most users read only chapters that are of interest to them. If you are designing the microcomputer hardware structure using the SCC as a peripheral, you will want to read the Initialisation Worksheet and Interrupt Routine Sections.

If you are programming a system using the SCC, you will be more interested, on the Initialization Worksheet Section.

Points To Watch Out For :

1. Follow the worksheet for initialization (page). Unexplainable operations may occur if this procedure is not followed.
2. Watch out for Write Recovery time violation (Interfacing Section). Both the CPU clock rate and the SCC clock rate will affect the Write Recovery time.
3. Ensure Mode bits are not changed when writing Commands. (Register Overview page 75). Each Mode bit affects only one function and a Command bit entry requires a rewrite of the entire register ; therefore, care must be taken to insure the integrity of the Mode bits whenever a new command is issued.
4. Data must be valid prior to falling edge of \overline{WR} or \overline{DS} .
5. If not used, \overline{INTACK} should be tied high.

Temperature Range

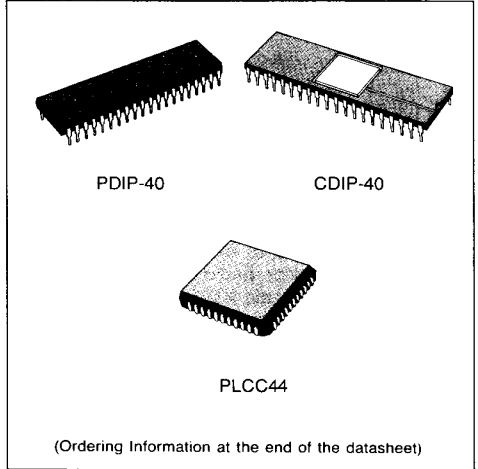
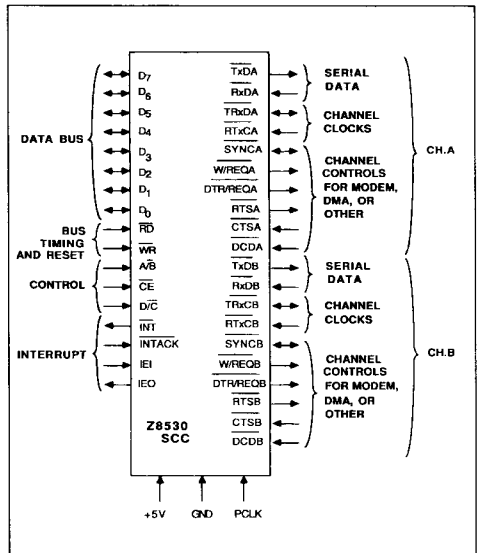

Figure 1 : Logic Functions.



CAPABILITIES

- Two independent full-duplex channels.
- Synchronous/Isosynchronous data rates :
 - Up to 1/4 of the PCLK (i.e., 1 Mbit/sec. maximum data rate with 4 MHz PCLK. Using external phase-lock loop).
 - Up to 375 Kbit/sec. with a 6 MHz clock rate.
 - Up to 250 Kbit/sec. with a 4 MHz clock rate (FM encoding using digital phase-locked loop).
 - Up to 187.5 Kbit/sec. with a 6 MHz clock rate Up to 125 Kbit/sec. with a 4 MHz clock rate (NRZI encoding using digital phase-locked loop).
- Asynchronous capabilities :
 - 5, 6, 7, or 8 bits per character
 - 1, 1-1/2, or 2 stop bits
 - Odd or even parity
 - Times 1, 16, 32, or 64 clock modes
 - Break generation and detection
 - Parity, overrun and framing error detection.
- Byte-oriented synchronous capabilities :
 - Internal or external character synchronization
 - 1 or 2 sync characters (6 or 8 bits/character) in separate registers
 - Automatic Cyclic redundancy check (CRC) generation/detection.
- SDLC/HDLC capabilities :
 - Abort sequence generation and checking
 - Automatic zero insertion and deletion
 - Automatic flag insertion between messages
 - Address field recognition
 - I-field residue handling
 - CRC generation/detection
 - SDLC loop mode with EOP recognition/loop entry and exit.
- Receiver data registers quadruply buffered. Transmitter data registered double buffered.
- NRZ, NRZI, or FM encoding/decoding.
- Baud-rate generator in each channel.
- Digital phase-locked loop for clock recovery.
- Crystal oscillator.

GENERAL DESCRIPTION

The SCC Serial Communications Controller is a dual-channel, multiprotocol data communications peripheral designed for use with 8-bit and 16-bit microprocessors. The SCC functions as a serial-to-parallel, parallel-to-serial converter/controller. The SCC can be software-configured to satisfy a wide variety of serial communications applications. The device contains a variety of new, sophisticated internal functions including on-chip baud rate generators, digital phase-lock loops, and crystal oscillators, which dramatically reduce the need for external logic.

The SCC handles asynchronous formats, Synchronous byte-oriented protocols such as IBM Bisync, and Synchronous bit-oriented protocols such as HDLC and IBM SDLC. This versatile device supports virtually any serial data transfer application (telecommunications, cassette, diskette, tape drivers, etc.).

The device can generate and check CRC codes in any Synchronous mode and can be programmed to check data integrity in various modes. The SCC also has facilities for modem controls in both channels. In applications where these controls are not needed, the modem controls can be used for general-purpose I/O.

With access to 14 Write registers and 7 Read registers per channel, the user can configure the SCC so that it can handle all asynchronous formats regardless of data size, number of stop bits, or parity requirements. The SCC accommodates all synchronous formats including character, byte, and bit-oriented protocols.

Within each operating mode, the SCC also allows for protocol variations by checking odd or even parity bits, character insertion or deletion, CRC generation and checking/break and abort generation and detection, and many other protocol-dependent features.

The SCC Z8530 is designed for non-multiplexed buses and is easily interfaced to CPUs such as the 8080, Z80, 6800, 68000 and *Multibus.

GENERAL DESCRIPTION (cont'd)

Figure 2 and Figure 5 show block diagrams of the SCC. Received data enters the receive data pins and follows one of several data paths, depending on the state of the control logic. The contents of the registers and the state of the external control pins establish the internal control logic. Transmitted data follows a similar pattern of control, register, and external pin definition.

PIN DESCRIPTIONS

The SCC pins are divided into seven functional groups : Address/Data, Bus Timing and Reset, Device Control, Interrupt, Serial Data (both channels), Peripheral Control (both channels), and Clocks (both channels). Figures 3 and 4 show the Pin Confi-

guration in both the proposed packages, Dual in Line and Chip Carrier.

The Address/Data group consists of the bidirectional lines used to transfer data between the CPU and the SCC. The direction of these lines depends on whether the SCC is selected and whether the operation is a Read or a Write.

The Timing and Control groups designate the type of transaction to occur and when this transaction will occur. The Interrupt group provides inputs and outputs to conform to the bus specifications for handling and prioritizing interrupts. The remaining groups are divided into Channel A and Channel B groups for serial data (transmit or receive), periph-

Figure 2 : SCC Block Diagram.

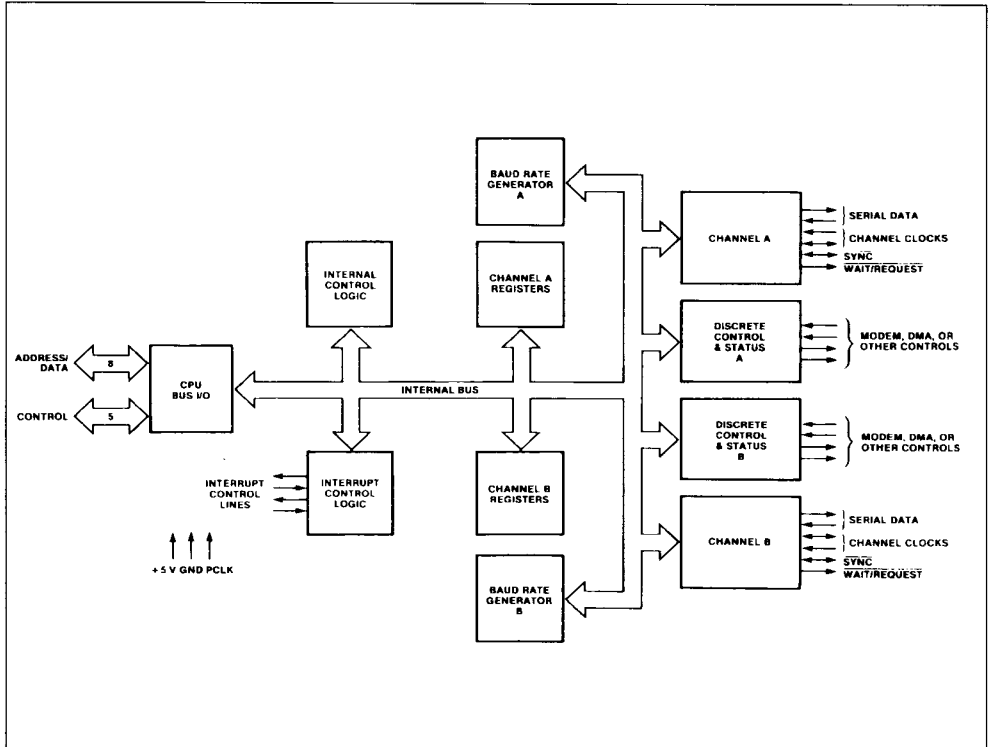

PIN DESCRIPTION (cont'd)

ral control (such as DMA or modem), and the input and output lines for the receive and transmit clocks. Here below are described the pin functions of the Z8530 Serial Communications Controller.

A/B. Channel A/Channel B Select (input, Channel A active HIGH). This signal selects the channel in which the Read or Write operation occurs.

CE. Chip Enable (input, active LOW). This signal selects the SCC for operation. It must remain active throughout the bus transaction.

D0-D7. Data Lines (bidirectional, 3-state). These I/O lines carry data or control information to and from the SCC.

D/C. Data/Control (input, Data active HIGH). This signal defines the type of information transfer performed by the SCC : data or control.

RD. Read (input, Active LOW). This signal indicates a Read operation and when the SCC is selected, enables the SCC bus drivers. During the interrupt acknowledge cycle, this signal gates the interrupt vector onto the bus if the SCC is the highest priority device requesting an interrupt.

WR. Write (input, active LOW). When the SCC is selected, this signal indicates a Write operation. The coincidence of RD and WR is interpreted as a Reset.

CTSA, CTSB. Clear to Send (inputs, active LOW). If these pins are programmed as auto enables, a LOW on these inputs enables the respective transmitters. If not programmed as auto enables, they may be used as general-purpose inputs. Both inputs are Schmitt-trigger buffered to accommodate slow rise-time inputs. The SCC detects transitions on these inputs and can interrupt the CPU on either logic level transitions.

DCDA, DCDB. Data Carrier Detect (inputs, active LOW). These pins function as receiver enables if they are programmed as auto enable bits ; otherwise they may be used as general-purpose input pins. Both pins are Schmitt-trigger buffered to accommodate slow rise-time signals. The SCC detects transitions on these pins and can interrupt the CPU on either logic level transitions.

DTR/ REQA, DTR/ REQB. Data Carrier Detect (inputs, active LOW). These pins function as receiver enables if they are programmed into the DTR bit. They can also be used as general-purpose outputs (transmit) or as request lines for the DMA controller. The SCC allows full duplex DMA transfers.

IEI. Interrupt Enable In (input, active HIGH). IEI is used with IEO to form an interrupt daisy chain when there is more than one interrupt-driven device. A HIGH on IEI indicates that no other higher priority.

Figure 3 : DIP Pin Connections.

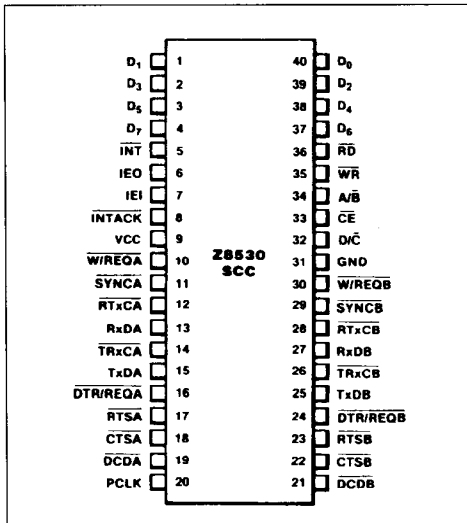
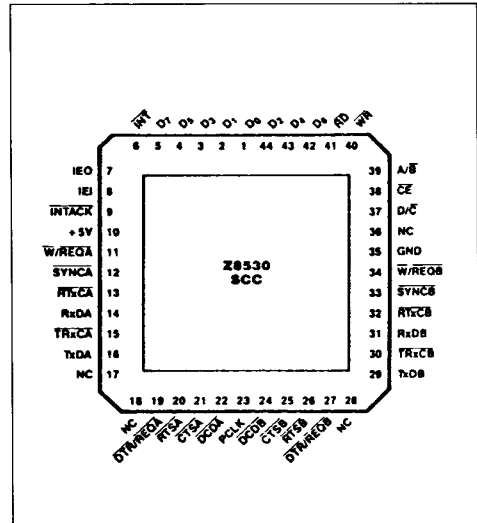

Figure 4 : Chip Carrier Pin Connection.



PIN DESCRIPTION (cont'd)

device has an Interrupt Under Service (IUS) or is requesting an interrupt.

IEO. Interrupt Enable Out (output, active HIGH). IEO is HIGH only if IEI is HIGH and the CPU is not servicing an SCC or SCC interrupt, or the controller is not requesting an interrupt (interrupt acknowledge cycle only). IEO is connected to the next lower priority device's IEI input and thus inhibits interrupts from lower priority devices.

INTACK. Interrupt Acknowledge (input, active LOW). This signal indicates an active interrupt acknowledge cycle. During this cycle, the interrupt daisy chain settles. When RD or DS becomes active, the SCC places an interrupt vector on the data bus (if IEI is HIGH). INTACK is latched by the rising edge of AS or PCLK.

INT. Interrupt Request (output, open-drain, active LOW). This signal is activated when the SCC is requesting an interrupt.

PCLK. Clock (input). This is the master clock used to synchronize internal signals. PCLK is not required to have any phase relationship with the master system clock. PCLK is a TTL level signal.

RTSA, RTSB. Request to Send (outputs, active LOW). When the Request to Send (RTS) bit in Write Register 5 (Figure 48) is set, the RTS signal goes LOW. When the RTS bit is reset in the Asynchronous mode and auto enables is on, the signal goes HIGH after the transmitter is empty. In Synchronous mode or in Asynchronous mode with auto enables off, the RTS pins strictly follow the state of the RTS bit. Both pins can be used as general-purpose outputs.

RTxCA, RTxCB. Receive/ Transmit Clocks (inputs, active LOW). The functions of these pins are under program control. In each channel, RTxC may supply the receive clock, the transmit clock, the clock for the baud rate generator, or the clock for the digital phase-locked loop (refer to Section 4 for bit configurations). These pins can also be programmed for use the respective SYNC pins as a crystal oscillator. The receive clock may be 1, 16, 32, or 64 times the data rate in asynchronous modes.

RxDA, RxDB. Receive Data (inputs, active HIGH). These input signals receive serial data at standard TTL levels.

SYNCA, SYNCB. Synchronization (inputs/outputs, active LOW). These pins can act as either inputs, outputs, or as part of the crystal oscillator circuit. In the Asynchronous Receive mode (crystal oscillator option not selected), these pins are inputs similar to CTS and DCD. In this mode, transitions on these lines affect the state of the Sync/ Hunt status bits in Read Register 0 (Figure 59), but have no other function.

In External Synchronization mode with the crystal oscillator not selected, these lines also act as inputs. In this mode, SYNC must be driven LOW two receive clock cycles after the last bit in the sync character is received. Character assembly begins on the rising edge of the receive clock immediately preceding the activation of SYNC.

In the Internal Synchronization mode, (Monosync and Bisync) with the crystal oscillator not selected, these pins act as outputs and are active only during the part of the receive clock cycle in which sync characters are recognized. The sync condition is not latched, so these outputs are active each time a sync character is recognized (regardless of character boundaries). In SDLC mode, these pins act as outputs and are valid on receipt of a flag.

TRxCA, TRxCB. Transmit/ Receive Clocks (inputs or outputs, active LOW). The functions of these pins are under program control. TRxC may supply the receive clock or the transmit clock in the Input mode or supply the output of the digital phase-locked loop, the crystal oscillator, the baud rate generator, or the transmit clock in the output mode. (Refer to Section 4 for bit configuration).

TxDA, TxDB. Transmit Data (outputs, active HIGH). This output signal transmits serial data at standard TTL levels.

W/ REQA, W/ REQB. Wait/ Request (outputs, open drain when programmed for Wait function, driven HIGH or LOW when programmed for a Request function). These dual-purpose outputs can be programmed as Request (receive) lines for a DMA controller or as Wait lines to synchronize the CPU to the SCC data rate. The reset state is Wait. The SCC allows full duplex DMA transfer.

OVERVIEW

The SCC internal structure provides all the interrupt and control logic necessary to interface with non-multiplexed bus. Interface logic is also provided to monitor modem or peripheral control inputs and outputs. All of the control signals are general purpose and can be applied to various peripheral devices as well as used for modem control.

The center for data activity revolves around the internal read and write registers. The programming of these registers provides the SCC with functional "personality" ; i.e., register values can be assigned before or during program sequencing to determine how the SCC will establish a given communication protocol.

Register Functions

All modes of communication are established by the bit values of the write registers. As data is received or transmitted, read register values may change. These changed values can promote software action or internal hardware action for further register changes.

The register set for each channel includes 14 write registers and seven read registers. Ten write registers are used for control, two for sync character generation, and two for baud rate generation. In addition there are two write registers which are shared by both channels ; one is the interrupt vector register and one is the master interrupt control and reset register. Four read registers indicate status information, two are for baud rate generation, and one for the receive buffer. In addition there are two read registers which are shared by both channels ; one for the interrupt pending bits and one for interrupt vector.

Table 1 lists the assigned functions for each read and write register. The SCC contains only one WR2 (interrupt vector) and one WR9 (master interrupt control). Both registers are accessed and shared by either channel. Chapter 7 provides a detailed bit legend and description of each register.

Table 1 : Register Set.

Read Register Functions	
RR0	Transmitt/ Receive buffer status, and External status
RR1	Special Receive Condition status, residue codes, error conditions
RR2	Modified (Channel B only) interrupt vector and Unmodified interrupt vector (Channel A only)
RR3	Interrupt Pending bits (Channel A only)
RR8	Receive buffer
RR10	Miscellaneous XMTR, RCVR status parameters
RR12	Lower byte of baud rate generator time constant
RR13	Upper byte of baud rate generator time constant
RR15	External / Status interrupt control information
Write Register Functions	
WR0	Command Register, CRC initialization resets for various modes
WR1	Interrupt conditions, Wait / DMA request control
WR2	Interrupt vector (access through either channel)
WR3	Receive / Control parameters, number of bits per character, RxCRC enable
WR4	Transmit / Receive miscellaneous parameters and codes, clock rate, number of sync characters, stop bits, parity
WR5	Transmit parameters and control, number of Tx bits per character, TxCRC enable
WR6	Sync character (1 st byte) or SDLC flag
WR8	Transmitt buffer
WR9	Master interrupt control and reset (accessed through either channel), reset bits, control interrupt daisy chain
WR10	Miscellaneous transmitter/receiver control bits, NRZI, NRZ, FM encoding, CRC reset
WR11	Clock mode control, source of Rx and Tx clocks
WR12	Lower byte of baud rate generator time constant
WR13	Upper byte of baud rate generator time constant
WR14	Miscellaneous control bits : baud rate generator, Phase-Locked Loop control, auto echo, local loopback
WR14	External/ Status interrupt control information-control external conditions causing interrupts

OVERVIEW (cont'd)**Data Paths**

Figure 6 illustrates the data paths involved in the six major areas of the SCC :

- Transmitter
- Receiver
- Baud rate generator
- DPLL
- Clocking options
- Data encoding

All communication modes are established by programming the write registers. As data is received or transmitted, read register values may change, altering the direction of the data path. These changed values can promote software action or internal hardware action for further register changes.

Transmitter. The transmitter has an 8-bit Transmit Data register (WR8) loaded from the internal data bus and a Transmit Shift register loaded from either WR6, WR7, or the Transmit Data register. In byte-oriented modes, WR6 and WR7 can be programmed with sync characters. In Monosync mode, an 8-bit or 6-bit sync character is used (WR6), whereas a 16-bit sync character is used (WR6 and WR7) in Bisync mode. In bit-oriented synchronous modes, the flag contained in WR7 is loaded into the Transmit Shift register at the beginning and end of a message.

If asynchronous data is processed, WR6 and WR7 are not used and the Transmit Shift register is formatted with start and stop bits shifted out to the transmit multiplexer at the selected clock rate. Synchronous data (except SDLC/HDLC) is shifted to the CRC generator as well as to the transmit multiplexer.

SDLC/HDLC data is shifted to the CRC Generator and out through the zero insertion logic (which is disabled while the flags are being sent). A "0" is inserted in all address, control, information, and frame check fields following five contiguous "1s" in the data stream. The result of the CRC generator for SDLC data is also routed through the zero insertion logic and then to the transmit multiplexer.

Receiver. The receiver has a three deep 8-bit Data FIFO (paired with an 8-bit Error FIFO), and an 8-bit shift register. This arrangement creates a 3-byte delay time, which allows the CPU time to service an interrupt at the beginning of a block of high-speed data. With each Receive Data FIFO, the error FIFO stores parity and framing errors and other types of status information. The error FIFO is readable in Read Register 1.

Incoming data is routed through one of several paths depending on the mode and character length. In

Asynchronous mode, serial data enters the 3-bit delay (Figure 5) if the character length of seven or eight bits is selected. If a character length of five or six bits is selected, data enters the receive shift register directly.

In synchronous modes, the data path is determined by the phase of the receive process currently in operation. A synchronous receive operation begins with a hunt phase in which a bit pattern that matches the programmed sync characters (6-bit, 8-bit, or 16-bit is searched).

The incoming data then passes through the Sync register and is compared to a sync character stored in WR6 or WR7 (depending on which mode it is in). The monosync mode matches the sync character programmed in WR7 and the character assembled in the Receive Sync register to establish synchronization.

Synchronization is achieved differently in the Bisync mode. Incoming data is shifted to the Receive Shift register while the next eight bits of the message are assembled in the Receive Sync register. If these two characters match the programmed characters in WR6 and WR7, synchronization is established. Incoming data can then bypass the Receive Sync register and enter the 3-bit delay directly.

The SDLC mode of operation uses the Receive Sync register to monitor the receive data stream and to perform zero deletion when necessary ; i.e., when five continuous "1s" are received, the sixth bit is inspected and deleted from the data stream if it is "0". The seventh bit is inspected only if the sixth bit equals one. If the seventh bit is "0", a flag sequence has been received and the receiver is synchronized to that flag. If the seventh bit is a "1", an abort or an EOP (End Off Poll) is recognized, depending on the selection of either the normal SDLC mode or SDLC Loop mode.

The same path is taken by incoming data for both SDLC modes. The reformatted data enters the 3-bit delay and is transferred to the Receive Shift register. The SDLC receive operation begins in the hunt phase by attempting to match the assembled character in the Receive Shift Register with the flag pattern in WR7. Then the flag character is recognized, subsequent data is routed through the same path, regardless of character length.

Either the CRC - 16 or CRC - SDLC cyclic redundancy check (CRC) polynomial can be used for both Monosync and Bisync modes, but only the CRC - SDLC polynomial is used for SDLC operation. The data path taken for each mode is also different.

OVERVIEW (cont'd)

Figure 5 : Data Paths.

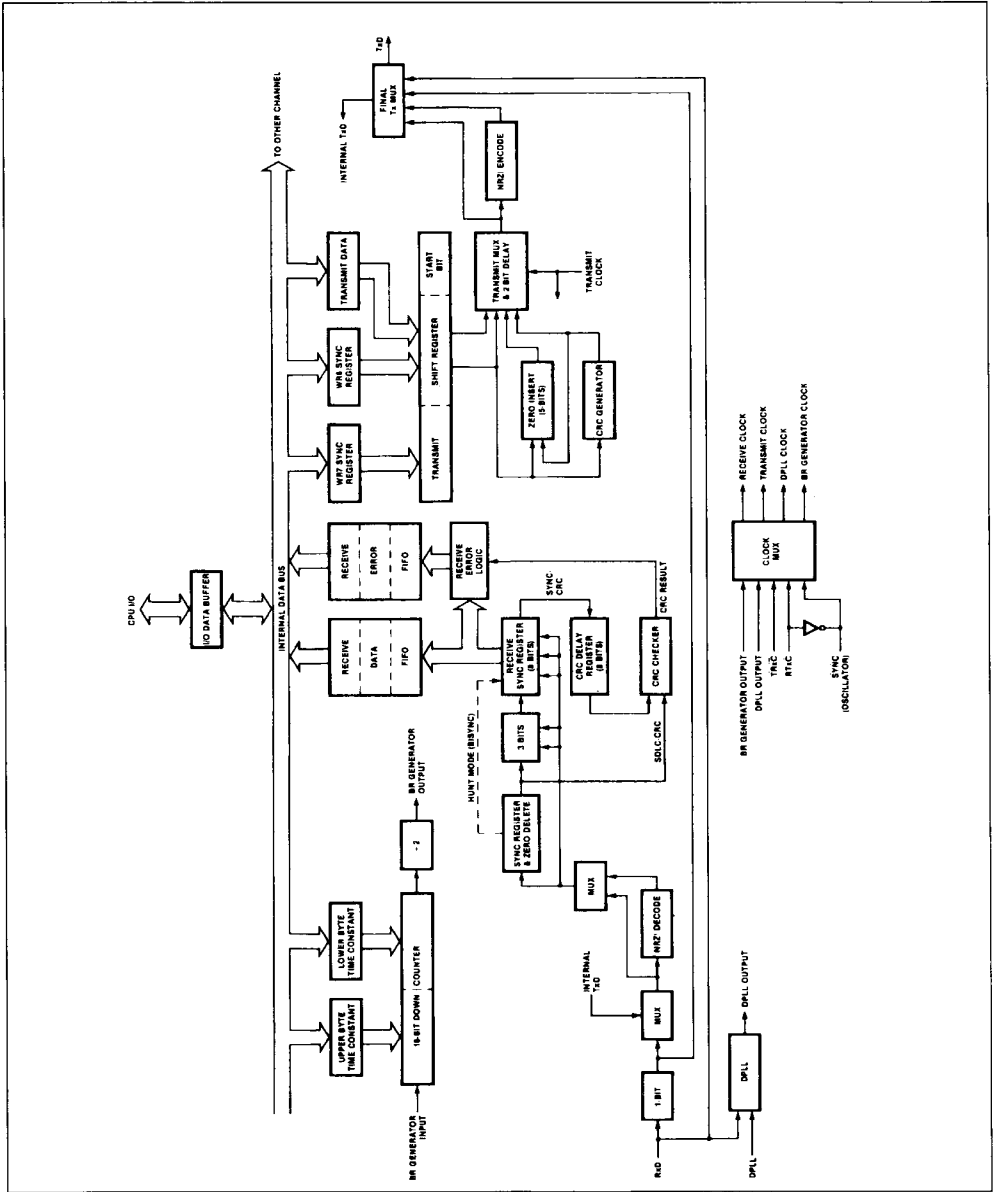

OVERVIEW (cont'd)

Bisync protocol is a byte-oriented operation that requires the CPU to decide whether or not a data character is to be included in CRC calculation. An 8-bit delay in all synchronous modes except SDLC is allowed for this process. In SDLC mode, all bytes are included in the CRC calculation.

Baud Rate Generator. Each channel in the SCC contains a programmable baud rate generator. Each generator consists of two 8-bit, time-constant registers forming a 16-bit time constant, a 16-bit down counter, and a flip-flop on the output that makes the output a square wave. On start-up, the flip-flop on the output is set High so that it starts in a known state, the value in the time-constant register is again loaded into the counter, and the counter begins counting down. When a count of zero is reached, the output of the baud rate generator toggles, the value in the time-constant register is loaded into the counter, and the process starts over. The time constant can be changed at any time, but the new value does not take effect until the next load of the counter.

No attempt is made to synchronize the loading of a new time constant with the clock used to drive the generator. When the time constant is to be changed, the generator should be stopped by writing to an en-

able bit in WR14. This ensures the loading of the correct time constant.

If neither the transmit clock nor the receive clock are programmed to come from the TRXC pin, the output of the baud rate generator may be made available for external use on the TRXC pin.

Digital Phase-locked Loop (DPLL). The SCC contains a digital phase-locked loop that can be used to recover clock information from a data stream with NRZI or FM coding. The DPLL is driven by a clock nominally 32 (NRZI) or 16 (FM) times the data rate. The DPLL uses this clock, along with the data stream, to construct a receive clock for the data. This clock can then be used as the SCC receive clock, the transmit clock, or both.

Clocking Options. The SCC can select several clock sources for internal and external use. Write Register 11 is the Clock Mode Control register for both the receive and transmit clocks. It determines the type of signal on the SYNC and RTxC pins and the direction of the TRxC pin.

Write Register 11 also controls the output of the baud rate generator, the DPLL output, and the selection of either a TT1 or XTAL output for the RTxC pin.

Figure 6 : Data Encoding Methods.

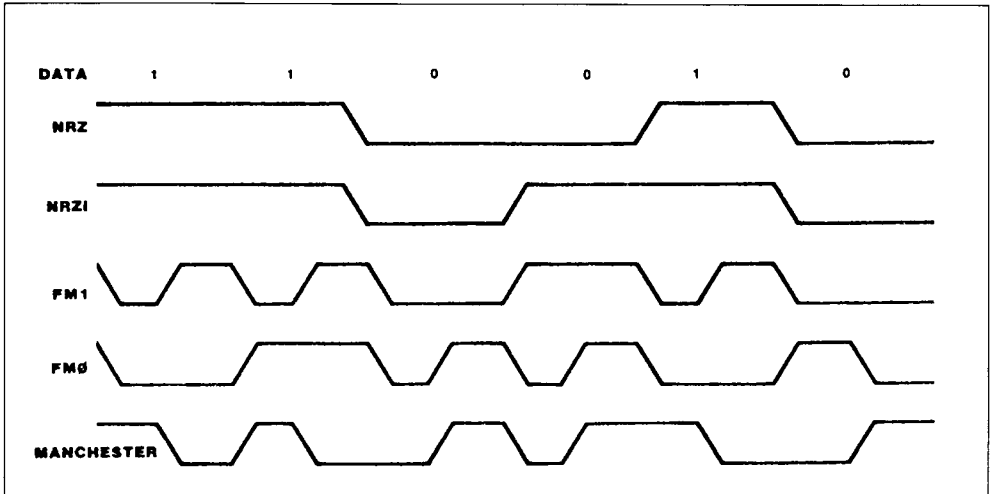

OVERVIEW (cont'd)

Data Encoding. Figure 6 illustrates the four encoding methods used by the SCC. In NRZ encoding, a "1" is represented by a High level and a "0" is represented by a Low level. In NRZI encoding, a "1" is represented by no change in level and a "0" is represented by a change in level. In FM1 (more properly, biphase mark), a transition occurs at the beginning of every bit cell. A "1" is represented by an additional transition at the center of the bit cell and a "0" is represented by the absence of a transition at the center of the bit cell. In FM0 (more properly, biphase space), a transition occurs at the beginning of every bit cell. A "0" is represented by an additional transition at the center of the bit cell and a "1" is represented by the absence of a transition at the center of the bit cell.

In addition to these four methods, the SCC can be used to decode Manchester (biphase level) data by using the DPLL in the FM mode and programming the receiver for NRZ data. Manchester encoding always produces a transition at the center of the bit cell. If the transition is Low to High, the bit is "0". If the transition is High to Low, the bit is "1".

Data Communications Capabilities

SCC logic handles all asynchronous, byte-oriented synchronous, and bit-oriented synchronous modes of operation. The following section briefly describes asynchronous, synchronous, and SDLC modes of communication.

Asynchronous. Figure 7 represents a typical asynchronous message format using one start bit, seven data bits, one parity bit, and one stop bit. A start bit is a High-to-Low transition detected by an asynchronous receiver and is actually an information bit notifying the receiver of an incoming message.

The start bit also initiates a clock circuit to provide latching pulses during expected data bit intervals. The parity bit is provided for error checking. The parity bit is calculated in both the receiver and the

transmitter ; the two results are compared to ensure that the expected and the actual bit values match. The stop bit returns the message unit to the quiescent marking state ; i.e., a constant high state condition lasts until the next High-to-Low start bit indicates an incoming data byte. During reception, the start and stop bits are stripped away and checked for errors, leaving only the working data for CPU interaction. The number of selected bits for each asynchronous function may differ between the transmitter and the receiver.

Monosync Mode. Monosync and Bisync modes require clocking information to be transmitted along with the data either by a method of encoding data that contains clocking information, or by a modem that encodes or decodes clock information in the modulation process.

Start and stop bits are not required in synchronous modes. All bits are used to transmit data. This eliminates the "waste" characteristic of asynchronous communication.

Figure 8 shows the character format for synchronous transmission. For example, bits 1-8 might be one character and bits 9-13 part of another character ; or bit 1 might be part of one character, bits 2-9 part of a second character, and bits 10-13 part of a third character. The framing (where each character begins) of each character is accomplished by defining a synchronization character, commonly called a "sync character".

The CPU places the receiver in Hunt mode whenever transmission begins (or whenever a data dropout has occurred and the hardware determines that resynchronization is necessary). In Hunt mode, the receiver shifts a bit into the Receive Shift register and compares the contents of the Receive Shift register and with the sync character (stored in another register), repeating the process until a match occurs. When a match occurs, the receiver begins transferring bytes to the receive FIFO.

Figure 7 : Asynchronous Message Format.

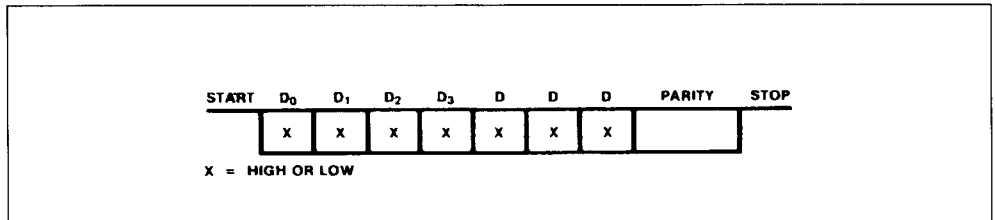

OVERVIEW (cont'd)

Bisynchronous Mode. The Bisync mode of operation (Figure 9) is similar to the Monosync mode, except that two sync characters are provided instead of one. Bisync attempts a more structured approach to synchronization through the use of special characters as message "headers" or "trailers". A detailed description of IBM's Bisync can be found in McNamara's Book (See Preface).

External Sync Mode. External Sync mode (Figure 10) eliminates the use of sync characters in the serial data stream by providing an external sync signal to mark the beginning of a data field; i.e., an external input pin (Sync) waits for an active state change to indicate the beginning of an information field.

SDLC Mode. Synchronous Data Link Control mode (SDLC) uses synchronization characters similar to Bisync and Monosync modes (such as flags and pad characters), but it is a bit-oriented protocol instead of byte-oriented protocol.

Any data communication link involves at least two stations. The station that is responsible for the data link and issues the commands to control the link is called the "primary station". The other station is a "secondary station". Not all information transfers need to be initiated by a primary station. In SDLC mode, a secondary station can be the initiator.

The basic format for SDLC is a "frame" (Figure 11). The information field is not restricted in format or content and can be of any reasonable length (including zero). Its maximum length is that which can be expected to arrive at the receiver error-free most of time. Hence, the determination of maximum length is a function of communication channel error rate.

The two flags that delineate the SDLC frame serve as reference points when positioning the address and control fields, and they initiate the transmission error check. The ending flag indicates to the receiving station that the 16 bits just received constitute the frame check. The ending flag could be followed by another frame, another flag, or an idle. This means that when two frames follow one another, the intervening flag may simultaneously be the ending flag of the first frame and the beginning flag of the next frame. Since the SDLC mode does not use characters of defined length, but rather works on a bit-by-bit basis, the 01111110 (7EH) flag can be recognized at any time.

To ensure that the flag is not sent accidentally, SDLC procedures require a binary "0" to be inserted by the transmitter after the transmission of any five contiguous "1s". The receiver then removes the "0" following a received succession of five "1s". Inserted and removed "0s" are not included in the CRC calculation.

The address field is 8 bits long and designates the number of secondary station to which the commands or data from the primary station are sent. The control field is eight bits long and is used to initiate all SDLC activities.

The SCC can also serve the High-level synchronous Data Link Communication (HDLC) protocol, which is identical to SDLC except for differences in framing.

SDLC Loop Mode. The SCC supports SDLC Loop mode in addition to normal SDLC. SDLC Loop mode is very similar to normal SDLC but is usually used in application where a point-to-point network is not ap-

Figure 8 : Monosync Data Character Format.

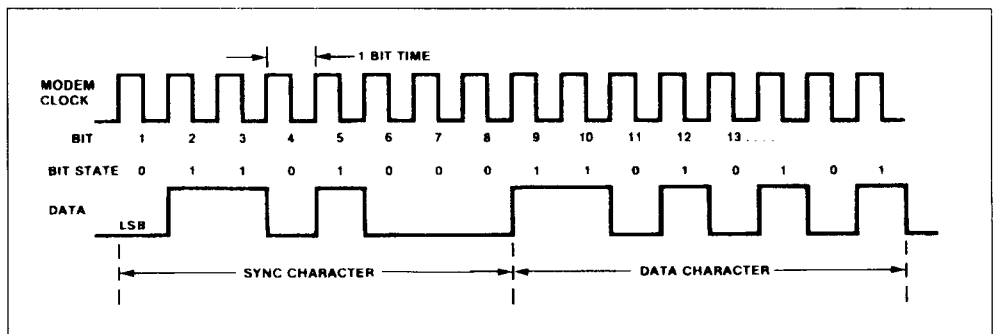

OVERVIEW (cont'd)

appropriate (for example, Point-Of-Sale terminals). In an SDLC Loop there is a primary station, called the controller, that manages the message traffic flow on the loop, and there are any number of secondary stations.

A secondary station in an SDLC loop is always listening to the messages being sent around the loop, and must pass these messages to the rest of the loop by retransmitting them with a one-bit-time delay. The secondary station can only place its own message on the loop at specific times. The controller signals that secondary stations may transmit messages by sending a special character, called an EOP (End of Poll), around the loop. The EOP character is the bit pattern 11111110. Because of zero insertion during messages this bit pattern is unique and thus is easily recognized.

When a secondary station has a message to transmit and it recognizes an EOP on the line, the first thing that it does is to change the last 1 or the EOP to a "0" before transmitting it. This turns the EOP into a Flag sequence. The secondary station now places its message on the loop and terminates its message with an EOP. Any secondary stations further down the loop with messages to transmit can

then append its message to the message of the first secondary station by the same process. All secondary stations without messages to send merely echo the incoming messages and are prohibited from placing messages on the loop, except upon recognizing an EOP.

There are also restrictions as to when and how a secondary station physically becomes part of the loop. A secondary station that has just powered up must monitor the loop, without the one-bit-time delay, until it recognizes an EOP. When an EOP is recognized the one-bit-time delay is switched on. This does not disturb the loop because the line is marking idle between the time that the controller sends the EOP and the time that it receives the EOP back. The secondary station that has gone on-loop cannot place a message on the loop until the next time that an EOP is issued by the controller. A secondary station goes off-loop in a similar manner. When given a command to go off-loop, the secondary station waits until the next EOP to remove the one-bit-time delay.

To operate the SCC in SDLC Loop mode, the SCC must first be programmed just as if normal SDLC were to be used. Loop mode is then selected by writing the appropriate control word in WR10. The SCC

Figure 9 : Bisynchronous Message Format.

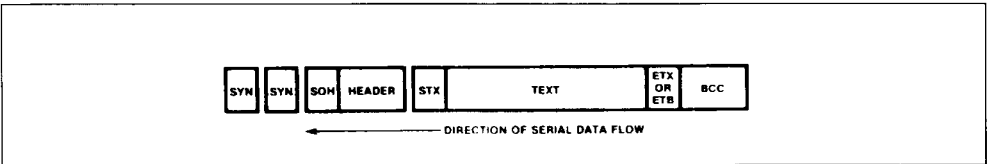

Figure 10 : External Sync Format.

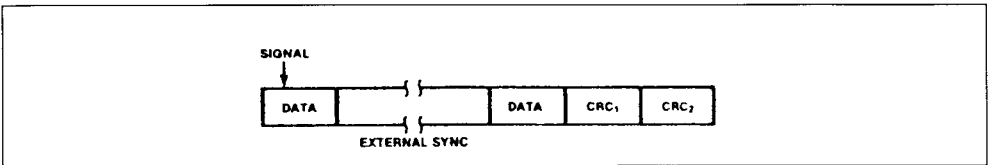
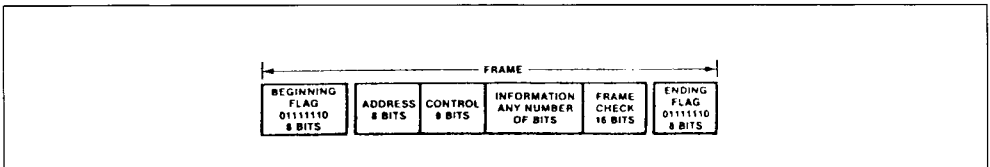

Figure 11 : SDLC Message Format.



OVERVIEW (cont'd)

is now waiting for the EOP so that it can go on loop. While waiting for the EOP, the SCC ties TxD to RxD with only the internal gate delays in the signal path. When the first EOP is recognized by the SCC, the Break/Abort/EOP bit is set in RR0, generating an External/Status interrupt (if so enabled). At the same time, the On-Loop bit in RR10 is set to indicate that the SCC is indeed on-loop, and a one-bit time delay is inserted in the TxD to the RxD patch.

The SCC is now on-loop but cannot transmit a message until a flag and the next EOP are received. The requirement that a flag be received ensures that the SCC cannot erroneously send messages until the controller ends the current polling sequence and starts another one.

A secondary station on the loop is prohibited from transmitting a message during a polling sequence unless it captures the line at the moment the EOP passes by. The SCC does this automatically. If the CPU in the secondary station with SCC needs to transmit a message, the Go-Active-On-Poll bit in WR10 must be set. If this bit is set when the EOP is detected, the SCC changes the EOP to a flag and starts sending another flag. The EOP is reported in the Break/Abort/EOP bit in RR0 and the CPU should write its data bytes to the SCC, just as in normal SDLC frame transmission. When the frame is complete and CRC has been sent, the SCC closes with a flag and reverts to One-Bit-Delay mode. The last zero of the flag, along with the marking line echoed from the RxD pin, form an EOP for secondary stations further down the loop. If the Go-Active-On-Poll bit is not set at the time the EOP passes by, the SCC cannot send a message until a flag (terminating the current polling sequence) and another EOP are received. While the SCC is actually transmitting a message, the loop-sending bit in R10 is set to indicate this.

If SDLC loop is de-selected, the SCC is designed to exit from the loop gracefully. When SDLC Loop mode is de-selected by writing to WR10, the SCC waits until the next polling cycle to remove the on-bit time delay. If a polling cycle is in progress at the time the command is written, the SCC finishes sending any message that it may be transmitting, ends with an EOP, and disconnects TxD from RxD. If no message was in progress, the SCC immediately disconnects TxD from RxD. To ensure proper loop operation after the SCC goes off the loop, and until the external relays take the SCC completely out of the loop, the SCC should be programmed for Mark idle instead of Flag idle. When the SCC goes off the loop, the On-Loop bit is reset.

The SCC allows the user the option of using NRZI in SDLC Loop mode by programming WR20 appropriately. With NRZI encoding, the outputs of secondary stations in the loop may be inverted from their inputs because of messages that they have transmitted. Removing the stations from the loop (removing the one-bit time delay) may cause problems further down the loop because of extraneous transitions on the line. The SCC avoids this problem by making transparent adjustments at the end of each frame it sends in response to an EOP. A response frame from the SCC is terminated by a flag and an EOP. Normally, the flag and the EOP share a zero, but if such sharing would cause the RxD and TxD pins to be of opposite polarity after the EOP, the SCC adds another zero between the flag and the EOP. This causes an extra line transition so that RxD and TxD are identical after the EOP is sent. This extra zero is completely transparent because it only means that the flag and the EOP no longer share a zero. All that a proper loop exit needs, therefore, is the removal of the one-bit time delay.

I/O Capabilities.

The SCC can work with three basic forms of I/O operations: polling, interrupts, and block transfer. All three I/O types involve register manipulation during initialization and data transfer.

Polling. During a polling sequence, the status of Read Register 0 is examined in each channel. This register indicates whether or not a receive or transmit data transfer is needed and whether or not any special conditions are present, e.g., errors.

This method of I/O transfer avoids interrupts. All interrupt functions must be disabled in order to operate the device in a polled environment. With no interrupts enabled, this mode of operation must initiate a read cycle of Read Register 0 to detect an incoming character before jumping to a data handler routine.

Interrupts. The SCC provides interrupt capability through the use of pins and a hardware scheme that enhances the maximum speed of serial data. Whenever the interrupt (INT) pin is active, the SCC is ready to transfer data.

Read and write registers are programmed so that an interrupt vector points to an interrupt service routine. The interrupt vector can also be modified to reflect various status conditions. Therefore, as many as eight different interrupt routines can be referenced.

Transmit interrupts, receive interrupts, and external/status interrupts are the main sources of interrupts. Each interrupt source is enabled under pro-

OVERVIEW (cont'd)

gram control, with channel A having a higher priority than channel B and with receive, transmit, and external/status interrupts prioritized respectively within each channel.

Block Transfers. The SCC provides a Block Transfer mode to accommodate CPU block transfer functions and DMA controllers. The Block Transfer mode uses the \overline{W}/REQ output in conjunction with the Wait/Request bits in Write Register 1.

The \overline{W}/REQ output can be defined by software as a \overline{WAIT} line in the CPU Block Transfer mode or as a $\overline{REQUEST}$ line in the DMA Block Transfer mode.

To a DMA controller, the SCC $\overline{REQUEST}$ output indicates that the SCC is ready to transfer data to or from memory. To the CPU, the \overline{WAIT} output indicates that the SCC is not ready to transfer data, thereby requesting the CPU to extend the I/O cycle.

INTERFACING THE SCC

This section covers the details of interfacing the Z8530 to a system. The general timing requirements for the device are described in the hardware information section.

Interfacing the Z8530

Two control signals, \overline{RD} and \overline{WR} , are used by the Z8530 to time bus transactions. In addition, four other control signals, \overline{CE} , D/\overline{C} , A/\overline{B} and \overline{INTACK} , are used to control the type of bus transaction that will occur. A bus transaction start when the addresses on D/\overline{C} and A/\overline{B} are asserted before \overline{RD} or \overline{WR} fall. The coincidence of \overline{CE} and \overline{RD} or \overline{CE} and \overline{WR} latches the state of D/\overline{C} and A/\overline{B} and starts the internal operation. The \overline{INTACK} signal must have been previously sampled High by a rising edge of $PCLK$ for a read or write cycle to occur. In addition to sampling \overline{INTACK} , $PCLK$ is used by the interrupt section to set the IP bits. The Z8530 generates internal control signals in response to a register access. Since \overline{RD} and \overline{WR} have no phase relationship with $PCLK$, the circuitry generating these internal control signals provides time for metastable conditions to disappear. This results in a recovery time related to $PCLK$. This recovery time applies only between transactions involving the Z8530, and any intervening transactions are ignored. This recovery time is four $PCLK$ cycles, measured from the falling edge of \overline{RD} or \overline{WR} in the case of a read or write of any register.

Z8530 Read Cycle Timing. The Read cycle timing for the Z8530 is shown in Figure 12. The address on A/\overline{B} and D/\overline{C} is latched by the coincidence of \overline{RD} and \overline{CE} active. \overline{CE} must remain LOW and \overline{INTACK} must remain HIGH throughout the cycle. The Z8530 bus drivers are enabled while \overline{CE} and \overline{RD} are both LOW. A read with D/\overline{C} HIGH does not disturb the state of the pointers and a read cycle with D/\overline{C} LOW resets the pointers to zero after the internal operation is complete.

Z8530 Write Cycle Timing. The Write cycle timing for the Z8530 is shown in Figure 13. The address on A/\overline{B} and D/\overline{C} , as well as the data on $D0-D7$, is latched by the coincidence of \overline{WR} and \overline{CE} active. \overline{CE} must remain LOW and \overline{INTACK} must remain HIGH throughout the cycle. A write cycle with D/\overline{C} HIGH does not disturb the state of pointers and a write cycle with D/\overline{C} LOW resets the pointers to zero after the internal operation is complete.

Z8530 Interrupt Acknowledge Cycle Timing. The interrupt Acknowledge cycle timing for the Z8530 is shown in Figure 14. The state of \overline{INTACK} is latched by the rising edge of $PCLK$. While \overline{INTACK} is LOW, the state of A/\overline{B} , \overline{CE} , D/\overline{C} , and \overline{WR} are ignored. Between the time \overline{INTACK} is first sampled LOW and the time \overline{RD} falls, the internal and external IEL/ IEO daisy chains settle; this is A.C. parameter #38 $TdIAi(RD)$. If there is an interrupt pending in the Z8530, and IEL is HIGH when \overline{RD} falls, the Interrupt Acknowledge cycle was intended for the Z8530. This being the case, the Z8530 sets the appropriate Interrupt Under Service latch, and places an interrupt vector on $D0-D7$. If the falling edge of \overline{RD} sets an IUS bit in the Z8530, the \overline{INT} pin goes active in response to the falling edge. Note that there should be only one \overline{RD} per Acknowledge cycle. Another important fact is that the IP bits in the Z8530 are updated by $PCLK$ divided by two, and this clock to update IPs is stopped while the pointers point to $RR2$ and $RR3$. This prevents data changing during a read, but will delay interrupt requests if the pointers are left pointing at these registers.

Z8530 Register Access. The registers in the Z8530 are accessed in a two-step process, using a Register Pointer to perform the addressing. To access a particular register, the pointer bits must be set by writing to $WR0$ the pointer bits may be written in either channel because only one set exists in the Z8530. After the pointer bits are set, the next read

INTERFACING THE SCC (cont'd)

or write cycle of the Z8530 having D/ \bar{C} LOW will access the desired register. At the conclusion of this read or write cycle the pointer bits are reset to "0s", so that the next control write will be to the pointers in WR0. A read or RR8 (the receive data buffer) or a write to WR8 (the transmit data buffer) may either be done in this fashion or by accessing the Z8530 having D/ \bar{C} pin HIGH. A read or write with D/ \bar{C} HIGH accesses the data registers directly, and independently, of the state of the pointer bits. This al-

lows single-cycle access to the data registers and does not disturb the pointer bits. The fact that the pointer bits are reset to "0", unless explicitly set otherwise, means that WR0 and RR0 may also be accessed in a single cycle. That is, it is not necessary to write the pointer bits with "0" before accessing WR0 or RR0. There are three pointer bits in WR0, and these allow access to the registers with addresses 0 through 7. Note that a command may be written to WR0 at the same time that the pointer

Figure 12 : Z8530 Read Cycle Timing.

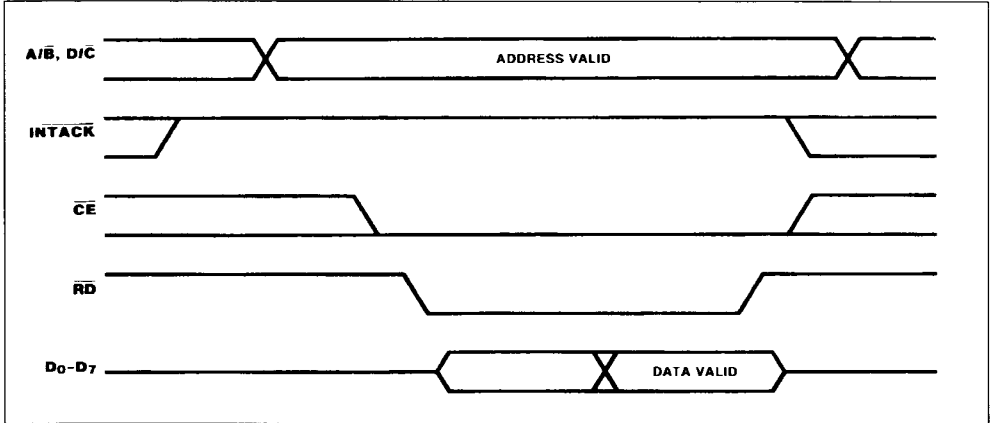
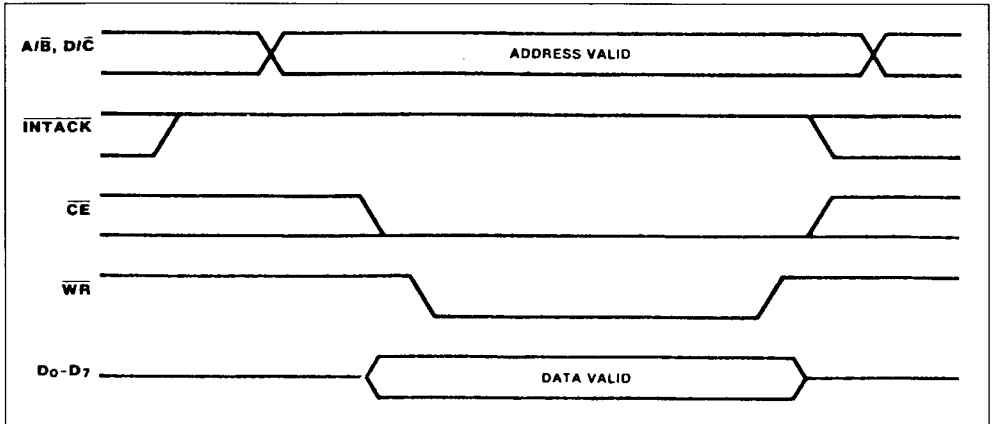
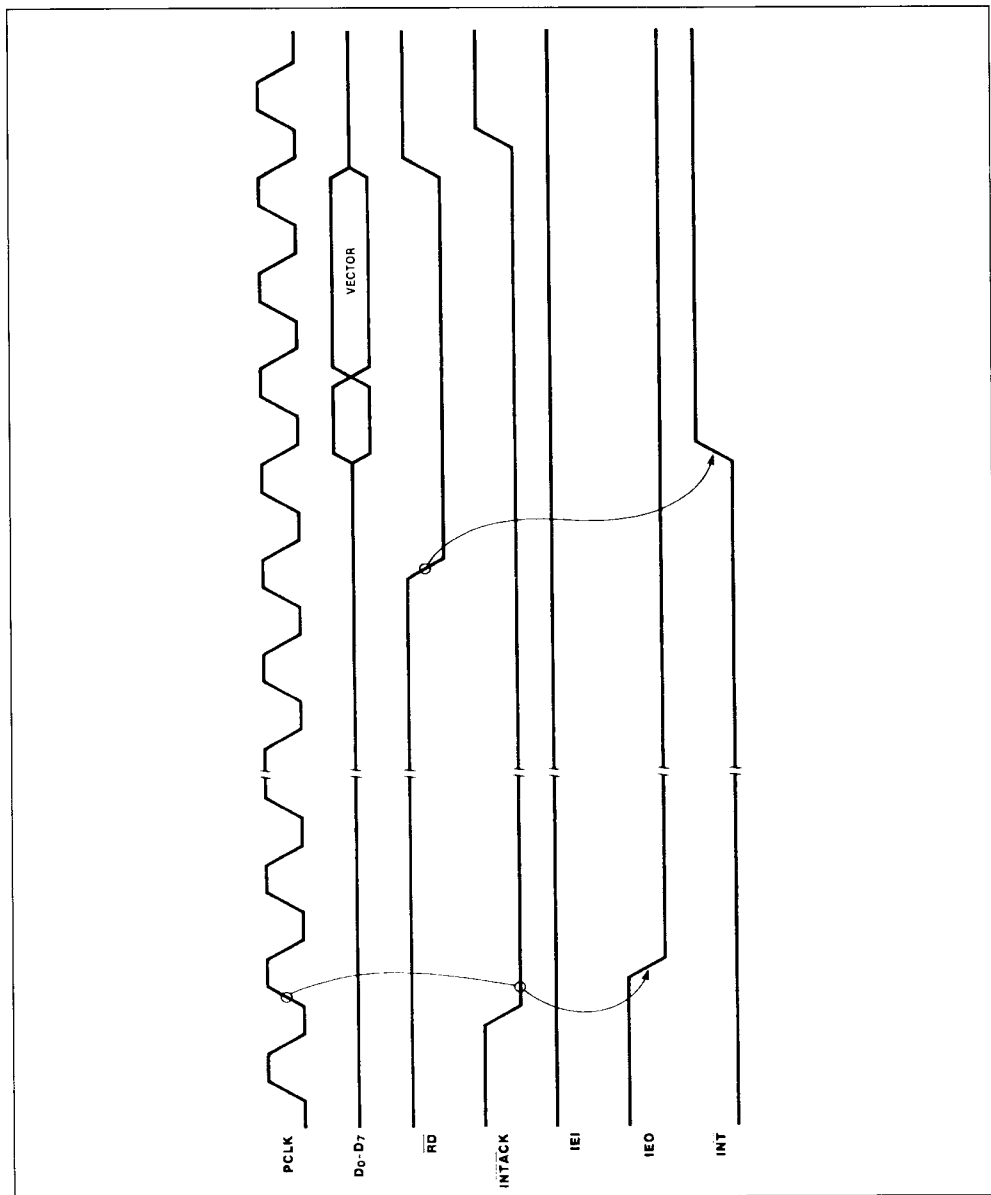

Figure 13 : Z8530 Write Cycle Timing.



INTERFACING THE SCC (cont'd)

Figure 14 : Z8530 Interrupt Acknowledge Details.



INTERFACING THE SCC (cont'd)

bits are written. To access the registers with addresses 8 through 15, a special command must accompany the pointer bits. This precludes concurrently issuing a command when pointing to these registers. The register map for the AmZ8530 is shown in Table 2. If for some reason, the state of the pointer bits is unknown they may be reset to "0" by performing a read cycle with the D/ \bar{C} pin held LOW. Once the pointer bits have been set, the desired channel is selected by the state of the A/ \bar{B} pin during the actual read or write of the desired register.

Z8530 Reset. The Z8530 may be reset by either hardware or software. Hardware reset occurs when \bar{RD} and \bar{WR} are both LOW, simultaneously, which is normally an illegal condition. As long as both \bar{RD} and \bar{WR} are LOW, the Z8530 recognizes the reset condition. Once this condition is removed, however, the reset condition is asserted internally for an additional four to five PCLK cycles. During this time any attempt to access the Z8530 will be ignored. The Z8530 has three software resets, encoded into command bits in WR9. There are two channel resets, which affect only one channel in the device and some of the bits in the write registers. The third command forces the same result as does a hardware reset. As in the case of a hardware reset, the Z8530 stretches the reset signal an additional four to five PCLK cycles beyond the ordinary valid access recovery time. The bits in WR9 may be written at the same time as the reset command because these bits are affected only by a hardware reset.

The reset values of the various registers are shown in Figure 15.

Table 2 : Z8530 Register Map.

A/B	PNT ₂	PNT ₁	PNT ₀	WRITE	READ
0	0	0	0	WR0B	RR0B
0	0	0	1	WR1B	RR1B
0	0	1	0	WR2	RR2B
0	0	1	1	WR3B	RR3B
0	1	0	0	WR4B	(RR0B)
0	1	0	1	WR5B	(RR1B)
0	1	1	0	WR6B	(RR2B)
0	1	1	1	WR7B	(RR3B)
1	0	0	0	WR0A	RR0A
1	0	0	1	WR1A	RR1A
1	0	1	0	WR2	RR2A
1	0	1	1	WR3A	RR3A
1	1	0	0	WR4A	(RR0A)
1	1	0	1	WR5A	(RR1A)
1	1	1	0	WR6A	(RR2A)
1	1	1	1	WR7A	(RR3A)
With the Point High Command					
0	0	0	0	WR8B	RR8B
0	0	0	1	WR9	RR13B
0	0	1	0	WR10B	RR10B
0	0	1	1	WR11B	(RR15B)
0	1	0	0	WR12B	RR12B
0	1	0	1	WR13B	RR13B
0	1	1	0	WR14B	(RR10B)
0	1	1	1	WR15B	RR15B
1	0	0	0	WR8A	RR8A
1	0	0	1	WR9	(RR13A)
1	0	1	0	WR10A	RR10A
1	0	1	1	WR11A	(RR15A)
1	1	0	0	WR12A	RR12A
1	1	0	1	WR13A	RR13A
1	1	1	0	WR14A	RR14A
1	1	1	1	WR15A	RR15A

INTERFACING THE SCC (cont'd)

Figure 15 : Z8530 Register Reset Values.

HARDWARE RESET								CHANNEL RESET								
7	6	5	4	3	2	1	0	7	6	5	4	3	2	1	0	
0	0	0	0	0	0	0	0	0	0	0	0	0	0	0	0	WR0
0	0	.	0	0	.	0	0	0	0	.	0	0	.	0	0	WR1
.	WR2
.	0	0	WR3
.	1	1	.	.	WR4
0	.	.	0	0	0	0	.	0	.	.	0	0	0	0	.	WR5
.	WR6
.	WR7
1	1	0	0	0	0	0	WR9
0	0	0	0	0	0	0	0	0	.	.	0	0	0	0	0	WR10
0	0	0	0	1	0	0	0	WR11
.	WR12
.	WR13
.	.	1	0	0	0	0	0	.	.	1	0	0	0	.	.	WR14
1	1	1	1	1	0	0	0	1	1	1	1	1	0	0	0	WR15
0	1	.	.	.	1	0	0	0	1	.	.	.	1	0	0	RR0
0	0	0	0	0	1	1	0	0	0	0	0	0	1	1	0	RR1
0	0	0	0	0	0	0	0	0	0	0	0	0	0	0	0	RR3
0	0	0	0	0	0	0	0	0	0	0	0	0	0	0	0	RR10

I/O PROGRAMMING CAPABILITIES

Regardless of the version of the SCC, all communication modes can use a choice of polling, interrupt and block transfer. These modes must be selected by the user to select the proper hardware and software required to supply data at the rate required.

Polling

This is the simplest mode to implement. The software must poll the SCC to determine when data is to be inputted or outputted from the SCC. In this mode, MIE (WR9 bit 3), and Wait/ DMA Request Enable (WR1 bit 7) are both reset to 0 to disable any requests. The software must then poll RR0 to determine the status of the receive buffer, transmit buffer and external status.

Interrupt Operations

The SCC, as a microprocessor peripheral, will request an interrupt only when it needs servicing. This allows the CPU to perform other operations while the SCC does not need service. The SCC has an internal priority resolution method to allow the highest priority interrupt to be serviced first.

The SCC is flexible with its interrupt method. The interrupt may be acknowledged with a vector transferred, acknowledged without a vector, or not acknowledged at all.

Interrupt Without Acknowledge. In this mode, the Interrupt Acknowledge signal does not have to be generated. This allows a simpler hardware design that does not have to meet the Interrupt acknowledge timing. Soon after the $\overline{\text{INT}}$ goes active, the interrupt controller will jump to the interrupt routine. In the interrupt routine, the code must read RR2 from Channel B to read the vector including status. When the vector is read from Channel B, it always includes the status regardless of the VIS bit (WR9 bit 0). The status given will decode the highest priority interrupt pending at the time it is read. The vector is not latched so that the next read could produce a different vector if another interrupt occurs. The register is disabled from change during the read operation to prevent an error if a higher interrupt occurs exactly during the read operation.

Once the status is read, the interrupt routine must decode the interrupt pending, and clear the condition. Removing the interrupt condition will clear the IP and bring $\overline{\text{INT}}$ inactive, as long as there are no other IP bits set. For example, writing a character to the transmit buffer will clear the transmit buffer empty IP.

When the interrupt IP, decoded from the status, is cleared RR2 can be read again. This allows the interrupt routine to clear all of the IP's within one interrupt request to the CPU.

Interrupt With Acknowledge. After the SCC brings $\overline{\text{INT}}$ active, the CPU must respond by bringing $\overline{\text{INTACK}}$ active. After enough time has elapsed to allow the daisy-chain to settle, the SCC will set the IUS bit for the highest priority IP. If the No Vector bit is not set (WR9 bit 1), the SCC will then place the interrupt vector on the data bus during a read. To speed the interrupt response time, the SCC can also modify 3 bits in the vector to indicate status. To include the status, the VIS bit (WR9 bit 0) must be set. The service routine must then clear the interrupting condition. For example, writing a character to the transmit buffer will clear the transmit buffer empty IP. After the interrupting condition is cleared, the routine can read RR3 to determine if any other IP's are set and clear them. At the end of the interrupt routine, a Reset IUS command (WR0) must be issued to unlock the daisy-chain and allow lower-priority interrupt requests. This is the only way, short of a software or hardware reset, that an IUS bit may be reset.

If the No Vector bit (WR9 bit 1) is set, the SCC will not place the vector on the data bus. An interrupt controller must then vector the code to the interrupt routine. The interrupt routine must then read RR2 from Channel B to read the status. This is the same as the case of an interrupt without an acknowledge except the IUS is set and the vector will not change until the Reset IUS command in RR0 is issued.

Interrupt Sources. Each channel in the SCC contains 3 sources of interrupt, making a total of 6. These 3 sources of interrupts are the receiver, the transmitter, and External/ Status conditions. In addition, there are several conditions that may cause these interrupts.

The receive interrupt request may either be caused by a receive character available or a special condition. The receive character available interrupt is generated when a character is loaded into the FIFO and is ready to be read. The special conditions are receive FIFO overrun, CRC/ framing error. End of frame, and parity. The parity special condition can be included as a special condition or not depending on bit 2 WR1. The special condition status can be read from RR1.

The transmit interrupt request has only one source. It can only be set when the transmit buffer goes from

I/O PROGRAMMING CAPABILITIES (cont'd)

full to empty. Note that this means that the transmit interrupt will not be set until after the first character is written to the SCC.

The External/ status Interrupts have several sources which may be individually enabled in WR15. The sources are zero count, DCD, Sync/ Hunt, CTS, transmitter underrun/ EOM and Break/ Abort.

Each source of interrupt in the SCC has three control/status bits associated with it. There are Interrupt Enable (IE), Interrupt Pending (IP), and Interrupt Under Service (IUS) (see Figure 16). The IE bit is written by the processor and serves to control interrupt requests from the SCC. If the IE bit is set for a given source of interrupt, then that source may cause an interrupt request when all of the necessary conditions are met. If the IE bit is reset, no interrupt request will be generated by that source. The IE bits are write-only in the SCC. The IP bit for a given source of interrupt condition in the SCC and is reset directly by the processor, or indirectly by some action that the processor may take. If the corresponding IE bit is not set, the IP bits in the SCC are read-only in RR3A. The IUS bits are completely hidden from the processor's view. An IUS is set during an Interrupt Acknowledge cycle for the highest-priority IP. See Table 3 for the interrupt priority. IUS is used to control the operation of the interrupt daisy chain by masking lower-priority interrupts. At the end of an interrupt service routine, the processor must issue a Reset Highest IUS command in WR0 to allow lower-priority interrupts. This is the only way, short of a software or hardware reset, that an IUS bit may be reset.

Table 3 : Interrupt Source Priority.

Receiver Channel A Transmit Channel A	High
External / Status Channel A	↓
Receiver Channel B Transmit Channel B	↓
External / Status Channel B	Low

Daisy-chain Priority Resolution. The six sources of interrupt in the SCC are prioritized in a fixed order via a daisy chain ; provision is made, via the IEI and IEO pins, for use of an external daisy chain as well. All Channel A interrupts are higher-priority than any Channel B interrupts, with the receiver, transmitter, and External/ Status interrupts prioritized in that order within each channel. The SCC requests an interrupt by pulling the INT pin Low from its open-drain state. This is controlled by the IP bits and the IEI input, among other things. A flowchart of the interrupt sequence for the SCC is shown in Figure 17. The internal daisy chain links the six sources of interrupt in a fixed order, chaining the IUS bits for each source. While an IUS is set, all lower-priority interrupt requests are masked off ; during an Interrupt Acknowledge cycle the IP bits are also gated into the daisy chain. This insures that the highest-priority IP will be selected to have its IUS set. The internal daisy chain may be controlled by the MIE bit in WR9. This bit, when reset, has the same effect as pulling the IEI pin Low, thus disabling all interrupt requests.

External Daisy Chain Operations. The SCC generates an interrupt request by pulling INT Low, but

Figure 16 : Peripheral Interrupt Structure.

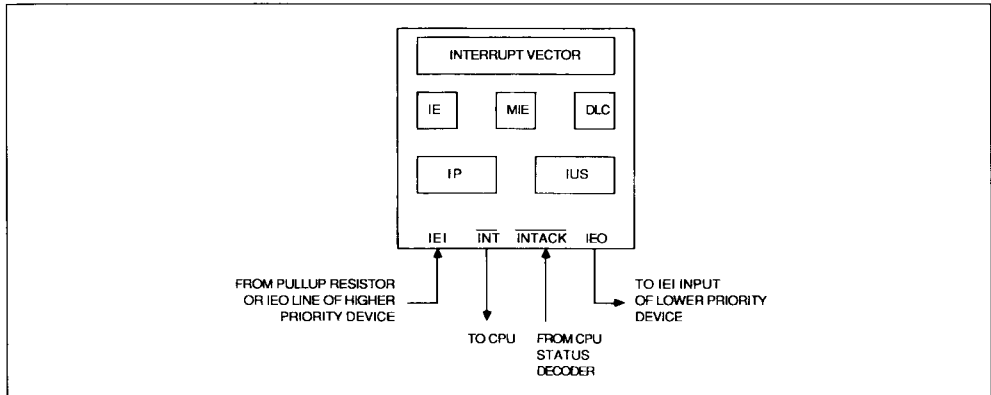

I/O PROGRAMMING CAPABILITIES (cont'd)

only if such interrupt requests are enabled (IE is 1, MIE is 1), an IP is set without a higher-priority IUS being set, or no higher-priority IUS being set, or no higher-priority interrupt is being serviced (IEI is High), or no Interrupt Acknowledge transaction is taking place. It is not pulled Low by the SCC at this time, but instead continues to follow IEI until an Interrupt Acknowledge transaction occurs. Some time after INT has been pulled Low, the processor initiates an Interrupt Acknowledge transaction. Between the time the SCC recognizes that an Interrupt Acknowledge cycle is in progress and the time during the acknowledge that the processor requests an interrupt vector, the IEI/IEO daisy chain settles. Any peripheral in the daisy chain having an Interrupt Pending (IP is 1) or an Interrupt Under Service (IUS is 1) holds its IEO line Low and all others make IEO follow IEI.

When the processor requests an interrupt vector, only the highest-priority interrupt source with a pending interrupt (IP is 1) has its IEI input High, its IE bit set to "1", and its IUS bit set to "0". This is the interrupt source being acknowledged, and at this point it sets its IUS bit to "1". If its NV bit is "0", the SCC identifies itself by placing the interrupt vector from WR2 on the data bus. If the NV bit is "1", the SCC data bus remains floating, allowing external logic to supply a vector. If the VIS bit in the SCC is "1", the vector also contains status information, encoded as shown in Table 4, which further describes the nature of the SCC interrupt. If the VIS bit is "0", the vector held in WR2 is returned without modification. If the SCC is programmed to include status information in the vector, this status may be encoded and placed in either bits 1-3 or in bits 4-6. This operation is selected by programming the Status High/Status Low bit in WR9. At the end of the interrupt service routine, the processor should issue the Reset Highest IUS command to unlock the daisy chain and allow lower-priority interrupt requests. The IP is reset during the interrupt service routine either directly by command, or indirectly, through some action taken by the processor. The external daisy chain may be controlled by the DLC bit in WR9. This bit, when set, forces IEO Low, disabling all lower-priority devices.

Receive Interrupts. The Receive Interrupt mode is controlled by WR1 bits 4 and 3. These select one of the four interrupt modes. The four modes are, Interrupt disabled, Interrupt on first character or special conditions, Interrupt on all characters or special conditions, and Interrupt on special conditions.

Receive Interrupts Disabled. This mode prevents the receiver from requesting an interrupt. It is used

Table 4 : Interrupt Vector Modification.

V3	V2	V1	Status High / status Low = 0
V4	V5	V6	Status High / status Low = 1
0	0	0	Ch B Transmit Buffer Empty
0	0	1	Ch B External / Status Change
0	1	0	Ch B Receive Character Avail.
0	1	1	Ch B Special Receive Condition
1	0	0	Ch A Transmit Buffer Empty
1	0	1	Ch A External / status Change
1	1	0	Ch A Receive Character Avail.
1	1	1	Ch A Special Receive Condition

in a polled environment where either the status bits in RR0 or the modified vector in RR2 (Channel B) is read. Although the receiver interrupts are disabled, the interrupt logic can still be used to provide status.

When these bits indicate that a received character has reached the top of the FIFO, the status in RR1 should be checked and then the data should be read. If status is to be checked, it must be done before the data is read, because the act of reading the data pops both the data and error FIFOs.

Receive Interrupt On First Character Or Special Condition. This mode is designed for use with DMA transfers of the receive characters. After this mode is selected, the first character received, or the first character already stored in the FIFO, will set the receiver IP. This IP will be reset when this character is removed from the SCC. No further receive interrupts will occur until the processor issues an Enable Interrupt on Next Receive Character command in WR0 until a special receive condition occurs. The SCC recognizes several special receive conditions. A receive overrun (where a character in the FIFO is written over) is a special receive condition, as is a framing error in Asynchronous mode, or the end-of-frame condition in SDLC mode. In addition, if D2 of WR1 is set, any character with a parity error will generate a special receive condition interrupt. The correct sequence of events when using this mode is to first select the mode and wait for the receive character available interrupt. When the interrupt occurs the processor should read the character and then enable the DMA to transfer the remaining characters. A special receive condition interrupt may occur any time after the first character is received, but is guaranteed to occur after the character having the special condition has been read. The status is not lost in this case, however, because the FIFO is locked by the special condition. In the service routine the processor should read RR1 to obtain the status, and may read the data again if necessary. The FIFO is unlocked by issuing an Error Reset command in WR0. If the special condition was End-

I/O PROGRAMMING CAPABILITIES (cont'd)

Figure 17 : Interrupt Flowchart.

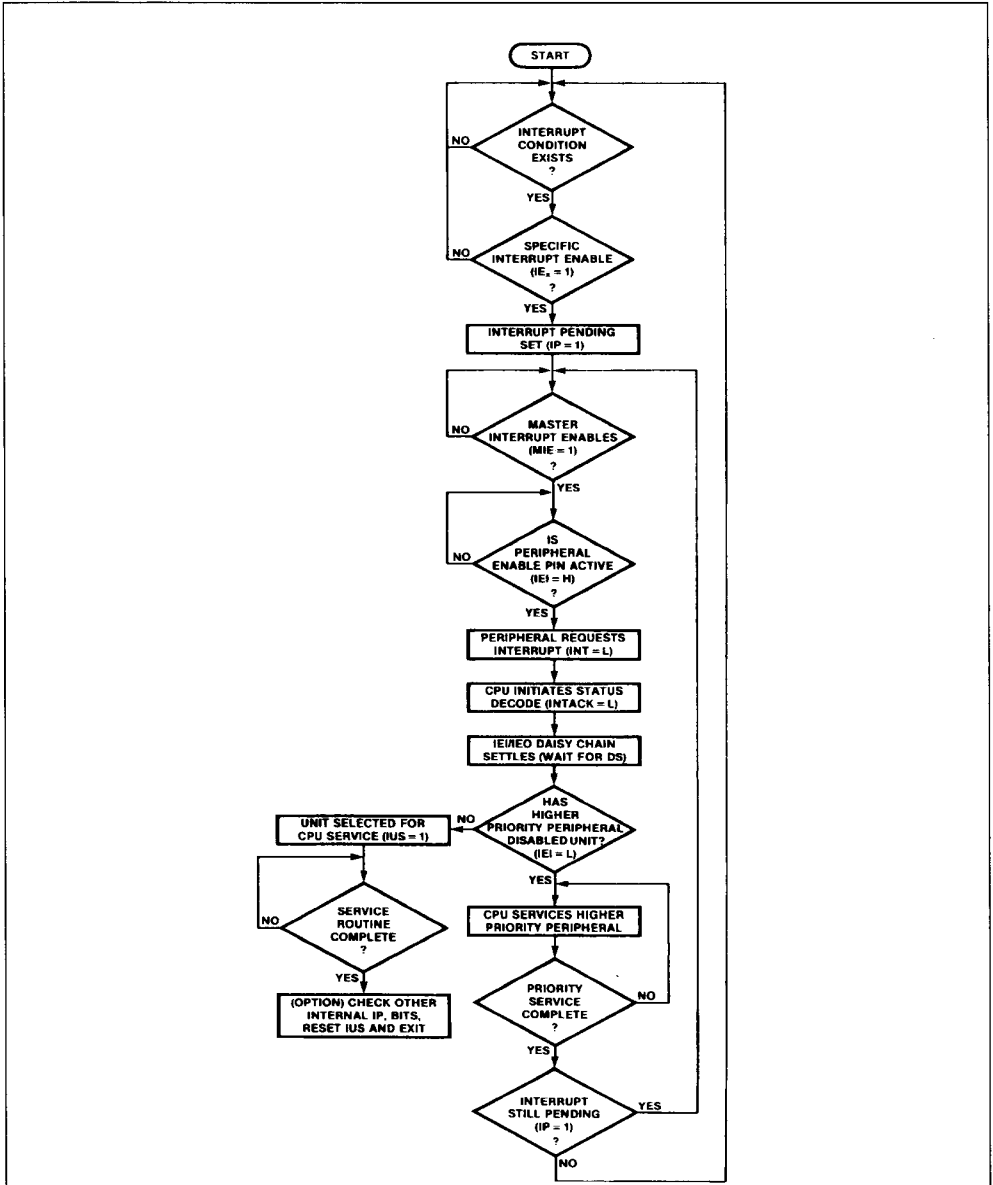

I/O PROGRAMMING CAPABILITIES (cont'd)

of-Frame, the processor should now issue the Enable Interrupt on Next Receive Character command to prepare for the next frame. The first character interrupt and special condition interrupt are distinguished by the status included in the interrupt vector. In all other respects they are identical, including sharing the IP and IUS bits.

Interrupt On All Receive Characters Or Special Conditions. This mode is designed for an interrupt-driven system. In this mode the SCC will set the receiver IP on every received character, whether or not it has a special receive condition. This includes characters already in the FIFO when this mode is selected. In this mode of operation the IP is reset when the character is removed from the FIFO, so if the processor requires status for any character, this status must be read before the data is removed from the FIFO. The special receive conditions are identical to those previously mentioned, and as before, the only difference between a "receive character available" interrupt and a "special receive condition" interrupt is the status encoded in the vector. In this mode a special receive condition does not lock the receive data FIFO so that the service routine must read the status in RR1 before reading the data. At moderate to high data rates, where the interrupt overhead is significant, time can usually be saved by checking for another received character before exiting the service routine. This technique eliminates the Interrupt Acknowledge and the processor-state-saving time, but care must be exercised because this receive character must be checked for special receive conditions before it is removed from the SCC.

Receive Interrupt On Special Conditions. This mode is designed for use with DMA transfers of the receive characters. In this mode, only receive characters with special conditions will cause the receiver IP to be set. All other characters are assumed to be transferred via DMA. No special initialization sequence is needed in this mode. Usually the DMA is initialized and enabled, and then this mode is selected in the SCC. A special receive condition interrupt may occur at any time after this mode is selected but the logic guarantees that the interrupt will not occur until after the character with the special condition has been read from the SCC. The special condition locks the FIFO so that the status will be valid when read in the interrupt service routine, and it guarantees that the DMA will not transfer any characters until the special condition has been serviced. In the service routine the processor should read RR1 to obtain the status and unlock the FIFO by issuing an Error Reset command. DMA transfer of the receive characters will then resume.

Transmit Interrupts. Transmit interrupts are controlled by the Transmit Interrupt Enable bit (D1) in WR1. If the interrupt capabilities of the SCC are not required, polling may be used. This is selected by disabling the transmit interrupts and polling the Transmit Buffer Empty bit in RR0. When the Transmit Buffer Empty is set a character may be written to the SCC without fear of writing over previous data. Another way of polling the SCC is to enable the transmit interrupt and then reset the MIE bit in WR9. The processor may then poll the IP bits in RR3A to determine when the transmit buffer is empty. Transmit interrupts should also be disabled in the case of DMA transfer of the transmitted data.

While the transmit interrupts are enabled the SCC will set the transmit IP whenever the transmit buffer becomes empty. This means that the transmit buffer must have been full before the transmit IP can be set. Thus when the transmit interrupts are first enabled, the transmit IP will not be set until after the first character is written to the SCC. In synchronous modes one other condition can cause the transmit IP to be set. This occurs at the end of a transmission after CRC is sent. When the last bit of CRC has cleared the Transmit Shift register and the flag or sync character is loaded into the Transmit Shift register, the SCC will set the transmit IP. Data for the new frame or block to be transmitted may be written at this time. In this particular case the Transmit Buffer Empty bit in RR0 is not set; only the transmit IP is set. If the transmit Buffer Empty bit is, in fact, set for the transmit interrupt that occurs immediately after CRC transmission, this indicates that data was written while CRC was being sent. This is an indication that the transmitter underflowed, without the CPU being aware of it. The transmit IP is reset either by writing data to the transmit buffer or by issuing the Reset Transmit IP command in WR0. Ordinarily the response to a transmit interrupt is to write more data to the SCC; however, at the end of a frame or block of data where CRC is to be sent next, the Reset Transmit IP command should be issued in lieu of data.

External/Status Interrupts. There are several sources of External/Status interrupts, each of which may be individually enabled in WR15. The master enable for the External/Status interrupts is located in WR1 (D0). The individual enable bits in WR15 control whether or not latches will be present in the path from the source of interrupt to the status bit in RR0. If an individual enable bit in WR15 is set to "0" the latches are not present in the signal path and the value read in RR0 reflects the current status. An interrupt source whose individual enable in WR15 is "0" is not a source of External/Status interrupts

I/O PROGRAMMING CAPABILITIES (cont'd)

even though the External/Status Interrupt Enable bit is set. When an individual enable in WR15 is set to "1", the latch is present in the signal path. The latches for the sources of External/Status interrupts are not independent. Rather, they all close at the same time as a result of a state change by one of the sources of interrupt. Thus, a read of RR0 returns the current status for any bits whose individual enable is "0" and either the current state or the latched state of the remainder of the bits. To guarantee the current status the processor should issue a Reset External/Status Interrupts command in WR0 to open the latches. The External/Status IP is set by the closing of the latches and remains set as long as they are closed. If the master enable for the External/Status interrupts is not set, the IP will never be set, even though the latches may be present in the signal paths and working as described. Because the latches close on the current status but give no indication of change, the processor must maintain a copy of RR0 in memory. When the SCC generates an External/Status interrupt the processor should read RR0 and determine which condition changed state and take appropriate action. The copy of RR0 in memory must then be updated and the Reset External/Status Interrupt command issued. Care must be taken in writing the interrupt service routine for the External/Status interrupts because it is possible for more than one status condition to change state at the same time. All of the latch bits in RR0 should be compared to the copy of RR0 in memory. If none have changed and the ZC interrupt is enabled, the Zero Count condition caused the interrupt.

The operation of the individual enable bits in WR15 for each of the six sources of External/Status interrupts is identical, but subtle differences exist in the operation of each source of interrupt. The six sources are Break/Abort, Underrun/EOM, CTS, DCD, Sync/Hunt and Zero Count. The Break/Abort, Underrun/EOM, and Zero Count conditions are internal to the SCC, while Sync/Hunt may be internal or external, and CTS and DCD are purely external signals. In the following discussions each source is assumed to be enabled, so that the latches are present, and the External/Status interrupts are enabled as a whole. Recall that the External/Status IP is set while the latches are closed and that the state of the signal is reflected immediately in RR0 if the latches are not present.

The Break/Abort status is used in asynchronous and SDLC modes but is always "0" in synchronous modes other than SDLC. In asynchronous modes this bit is set when a break sequence (null character plus framing error) is detected in the receive data stream, and remains set as long as "0s" continue

to be received. This bit is reset when a "1" is received. A single null character is left in the receive FIFO each time that the break condition is terminated. This character should be read and discarded. In SDLC mode this bit is set by the detection of an abort sequence, which is seven or more contiguous "1s" in the receive data stream. The bit is reset when a "0" is received. A received abort forces the receiver into Hunt, which is also an external/status condition. Though these two bits change state at roughly the same time, one or two External/Status interrupts may be generated as a result. The Break/Abort bit is unique in that both transitions are guaranteed to cause the latches to close, even if another External/Status interrupt is pending at the time these transitions occur. This guarantees that a break or abort will be caught.

The Transmit Underrun/ EOM bit is used in synchronous modes to control the transmission of CRC. This bit is reset by issuing the Reset Transmit Underrun/ EOM command in WR0. However, this transition does not cause the latches to close ; this occurs only when the bit is set. To inform the processor of this fact, the SCC sets this bit when CRC is loaded into the Transmit Shift register. This bit will also be set if the processor issues the Send Abort command in WR0. The bit is always set in Asynchronous mode.

The CTS bit reports the state of the $\overline{\text{CTS}}$ input, and the DCD bit reports the status of the DCD input. Both bits latch on either input transition. In both cases, after the Reset External/Status Interrupt command is issued, if the latches are closed, they remain closed if there is any odd number of transitions on an input ; they will be open if there is an even number of transitions on the input.

The Zero Count bit is set when the counter in the baud rate generator reaches a count of "0" and is reset when the counter is reloaded. The latches are closed only when this bit is set to "1", and the status in RR0 always reflects the current status. While the Zero Count IE bit in WR15 is reset this bit is forced to "0" .

There are a variety of ways in which the Sync/ Hunt may be set and reset, depending on the SCC's mode operation. In Asynchronous mode this bit reports the state of the $\overline{\text{SYNC}}$ pin, latching on both input transitions. The same is true of External Sync mode. However, if the crystal oscillator is enabled while in Asynchronous mode this bit will be forced to "0" and the latches will not be closed. Selecting the crystal option in External Sync mode is illegal, but the result will be the same. In Synchronous modes other than SDLC the Sync/Hunt reports the

I/O PROGRAMMING CAPABILITIES (cont'd)

Hunt state of the receiver. Hunt mode is entered when the processor issues the Enter Hunt command in WR3. This forces the receiver to search for a sync character match in the receive data stream. Because both transitions of the Hunt bit close the latches, issuing this command will cause an External/Status interrupt. The SCC resets this bit when character synchronization has been achieved, causing the latches to again be closed. In these synchronous modes the SCC will not reenter the Hunt mode automatically; only the Enter Hunt command will set this bit. In SDLC mode this bit is also set by the Enter Hunt command, but the receiver will also automatically enter the Hunt mode if an Abort sequence is received. The receiver leaves Hunt upon receipt of a flag sequence. Both transitions of the Hunt bit will cause the latches to be closed. In SDLC mode the receiver will automatically synchronize on Flag characters. The receiver is in Hunt mode when it is enabled, so the Enter Hunt command will probably never be needed.

If careful attention is paid to details, the interrupt service routine for External/Status interrupts is straightforward. To determine which bit or bits changed state, the routine should first read RR0 and compare it to a copy from memory. For each changed bit the appropriate action should be taken and the copy in memory updated. The service routine should close with a Reset External/Status interrupts command to reopen the latches. The copy of RR0 in memory should always have the Zero Count bit set to "0", since this will be the state of the bit after the Reset External/Status interrupts command at the end of the service routine. When the processor issues the Reset Transmit Underrun/EOM latch command in WR0, the Transmit Underrun/EOM bit in the copy of RR0 in memory should be reset because this transition does not cause an interrupt.

Block Transfers

The SCC offers several alternatives for the block transfer of data. The various options are selected by WR1 (bits D7 through D5) and WR14 (bit D2). Each channel in the SCC has two pins which may be used to control the block transfer data. Both pins in each channel may be programmed to act as DMA Request signals, and one pin in each channel may be programmed to act as a Wait signal for the CPU. In either mode, it is advisable to select and enable the mode in two separate accesses of the appropriate register. The first access should select the mode and the second access should enable the function. This procedure prevents glitches on the output pins. Reset forces Wait mode, with $\overline{W}/\overline{REQ}$ open-drain.

Wait On Transmit. The Wait function on transmit is selected by setting both D6 and D5 to "0" and then enabling the function by setting D7 of WR1 to "1". In this mode the $\overline{W}/\overline{REQ}$ pin carries the \overline{WAIT} signal, and is open-drain when inactive and Low when active. When the processor attempts to write to the transmit buffer when it is full, the SCC will assert \overline{WAIT} until the buffer is empty. This allows the use of a block-move instruction to transfer the transmit data. In the Z8530, \overline{WAIT} will go active in response to \overline{WR} going active, but only if the data buffer is being accessed, either directly or via the pointers. The \overline{WAIT} pin is released in response to the falling edge of PCLK. Details of the timing are shown in Figure 18.

Wait On Receive. The Wait function on receive is selected by setting D6 or WR1 to "0", D5 of WR1 to "1", and then enabling the function by setting D7 of WR1 to "1". In this mode the $\overline{W}/\overline{REQ}$ pin carries the \overline{WAIT} signal, and is open-drain when inactive and Low when active. When the processor attempts to read data from the receive FIFO when it is empty, the SCC will assert \overline{WAIT} until a character has reached the top of the FIFO. This allows the use of a block-move instruction to transfer the receive data. In the Z8530, \overline{WAIT} will go active in response to \overline{RD} going active, but only if the receive data FIFO is being accessed, either directly or via the pointers. The \overline{WAIT} pin is released in response to the falling edge of PCLK. Details of the timing are shown in Figure 19.

DMA Requests. The two DMA request pins $\overline{W}/\overline{REQ}$ and $\overline{DTR}/\overline{REQ}$ can be programmed to be used as DMA requests. The $\overline{W}/\overline{REQ}$ pin can be used as either a transmit or a receive request and the $\overline{DTR}/\overline{REQ}$ pin can only be used as a receive request. For full-duplex operation, the $\overline{W}/\overline{REQ}$ is, therefore, used for transmit and the $\overline{DTR}/\overline{REQ}$ is used for receive. These modes are described below.

DMA Request On Transmit (using $\overline{W}/\overline{REQ}$). The Request on Transmit function is selected by setting D6 of WR to "1", D5 of WR1 to "0", and then enabling the function by setting D7 of WR1 to "1". In this mode the $\overline{W}/\overline{REQ}$ pin carries the $\overline{REQUEST}$ signal, which is active Low. When this mode is selected, but not yet enabled, the $\overline{W}/\overline{REQ}$ is driven High. When the enable bit is set, $\overline{REQUEST}$ goes Low if the transmit buffer is empty at the time, or will remain High until the transmit buffer becomes empty. Note that the $\overline{REQUEST}$ pin will follow the state of the transmit buffer even though the transmitter is disabled. Thus, if the $\overline{REQUEST}$ is enabled, the DMA may write data to the SCC before the transmitter is enabled. This will not cause a problem in Asynchro-

I/O PROGRAMMING CAPABILITIES (cont'd)

nous mode but may cause problems in Synchronous mode because the SCC will send data in preference to flags or sync characters. It may also complicate the CRC initialization, which cannot be done until after the transmitter is enabled. With only one exception, the REQUEST pin directly follows the state of the transmit buffer in this mode. REQUEST goes Low when the transmit buffer empties and remains Low until the transmit buffer is filled. The SCC generates only one falling edge on REQUEST per character requested and the timing for this is shown in Figure 20. The one exception occurs in synchronous modes at the end of CRC transmission. At the end of CRC transmission, when the closing flag or sync character is loaded into the Transmit Shift register, REQUEST is pulsed High for one PCLK cycle. The DMA may use this falling edge on REQUEST to write the first character of the next frame or block to the SCC.

In the Z8530, REQUEST will go High in response to the falling edge of WR, but only when the appropriate transmit buffer in the SCC is accessed. This is shown in Figure 21.

DMA Request On Transmit (using DIR/REQ). A second Request on Transmit function is available on the DTR/REQ pin. This mode is selected by setting D2 of WR14 to "1". When this bit is set to "1", REQUEST goes Low if the transmit buffer is empty at the time, or will go High until the transmit buffer becomes empty. While D2 of WR14 is set to "0", the DTR/REQ pin is DTR and follows the inverted state of D7 in WR5. This pin will be High after a channel or hardware reset and in the DTR mode. In the Request mode REQUEST will follow the state of the transmit buffer even though the transmitter is disabled. Thus if REQUEST is enabled before the transmitter is enabled, the DMA may write data to the SCC before the transmitter is enabled. This will not cause a problem in Asynchronous mode, but may cause problems in Synchronous mode because the SCC will send data in preference to flags or sync characters. It may also complicate the CRC initialization, which cannot be done until after the transmitter is enabled. With only one exception, the REQUEST pin directly follows the state of the transmit buffer in this mode. REQUEST goes Low when the transmit buffer empties and remains Low until the transmit buffer is filled. The SCC generates only one falling edge on REQUEST per character requested. The one exception occurs in synchronous modes at the end of CRC transmission. At the end of CRC transmission, when the closing flag or sync character is loaded into the Transmit Shift register, REQUEST is pulsed High for one PCLK cycle. The DMA may use this falling edge on REQUEST to

write the first character of the next frame or block to the SCC. The Request signal on DTR/REQ differs from the one on W/REQ in that it does not go immediately High in response to the access which writes to the transmit buffer. This is because the registers in the SCC are not written during the actual access, but are delayed by some number of PCLK cycles. The Request signal on DTR/REQ follows the state of the transmit buffer exactly while the Request signal on W/REQ goes inactive in anticipation of the transmit buffer becoming full. The timing of the Request signal on both pins is shown in Figure 21.

DMA Request On Receive. The Request on Receive function is selected by setting D6 and D5 of WR1 to "1" and then enabling the function by setting D7 of WR1 to "1". In this mode the W/REQ pin carries the REQUEST signal, which is active Low. When this mode is selected, but not yet enabled, the W/REQ pin is driven High. When the enable bit is set REQUEST goes Low if the receive buffer contains a character at the time, or will remain High until a character enters the receive buffer. Note that the REQUEST pin will follow the state of the receive buffer even though the receiver is disabled. Thus, if the receiver is disabled and REQUEST is still enabled, the DMA will transfer the previously received data correctly. In this mode the REQUEST pin directly follows the state of the receive buffer with only one exception. REQUEST goes Low when a character enters the receive buffer and remains Low until this character is removed from the receive buffer. The SCC generates only one falling edge on REQUEST per character transfer requested and the timing for this is shown in Figure 22. The one exception occurs in the case of a special receive condition in the Receive Interrupt on First Character or Special Condition mode, or the Receive Interrupt on Special Condition Only mode. In the two interrupt modes any receive character with a special receive condition is locked at the top of the FIFO until an Error Reset command is issued. This character in the receive FIFO would ordinarily cause additional DMA Requests after the first time it is read. However, the logic in the SCC guarantees only one falling edge on REQUEST by holding REQUEST High from the time the character with the special receive condition is read, and the FIFO locked, until after the Error Reset command has been issued. Once the FIFO is unlocked by the Error Reset command, REQUEST again follows the state of the receive buffer. In the Z8530, REQUEST will go High in response to the falling edge of RD, but only when the appropriate receive buffer in the SCC is accessed. This is shown in Figure 23.

I/O PROGRAMMING CAPABILITIES (cont'd)

Figure 18 : Wait on Transmit.

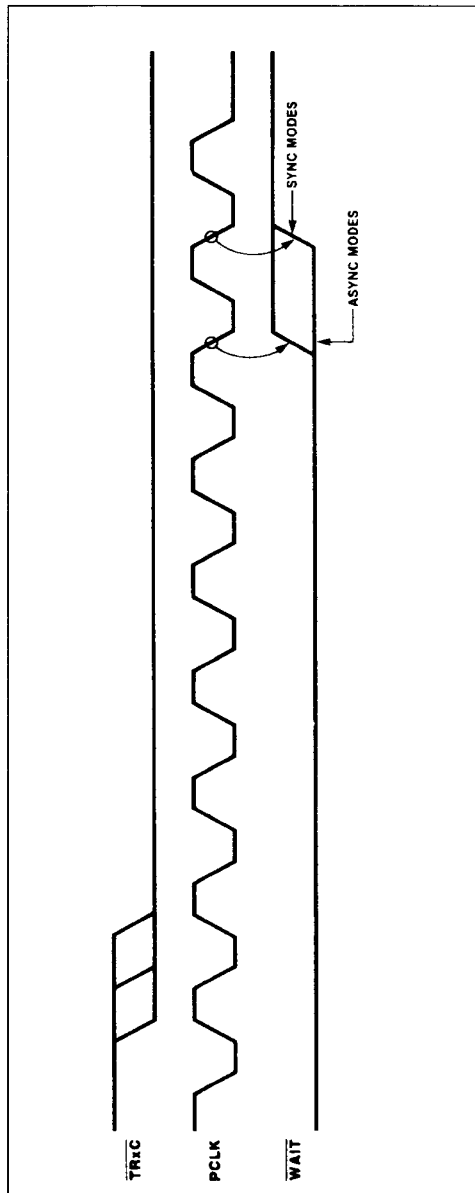
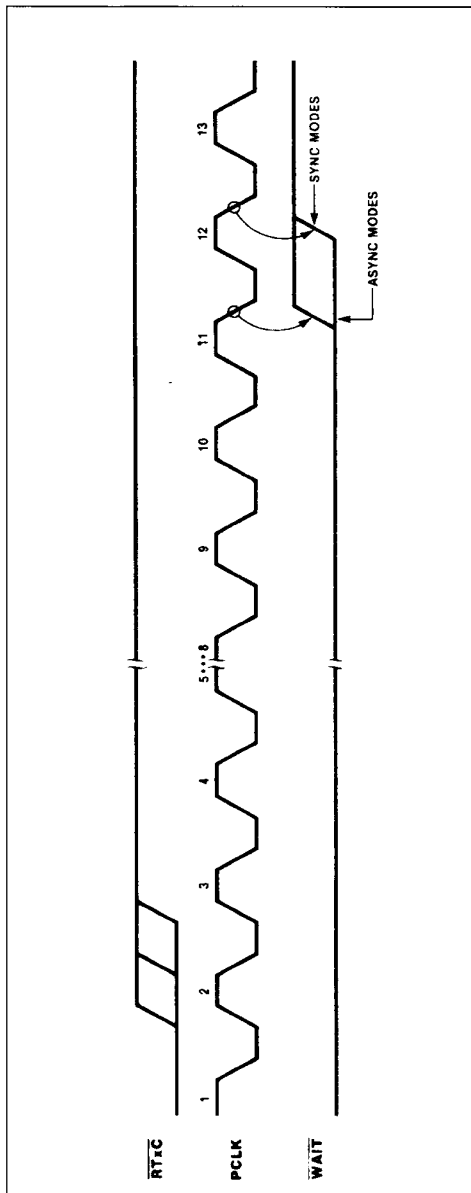

Figure 19 : Wait on Receive.



I/O PROGRAMMING CAPABILITIES (cont'd)

Figure 20 : Transmit Request Assertion.

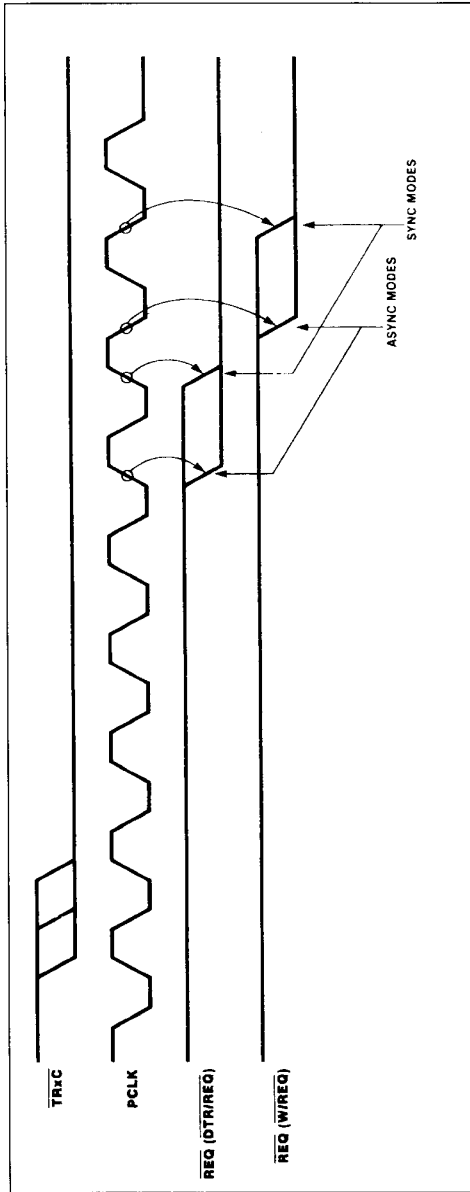
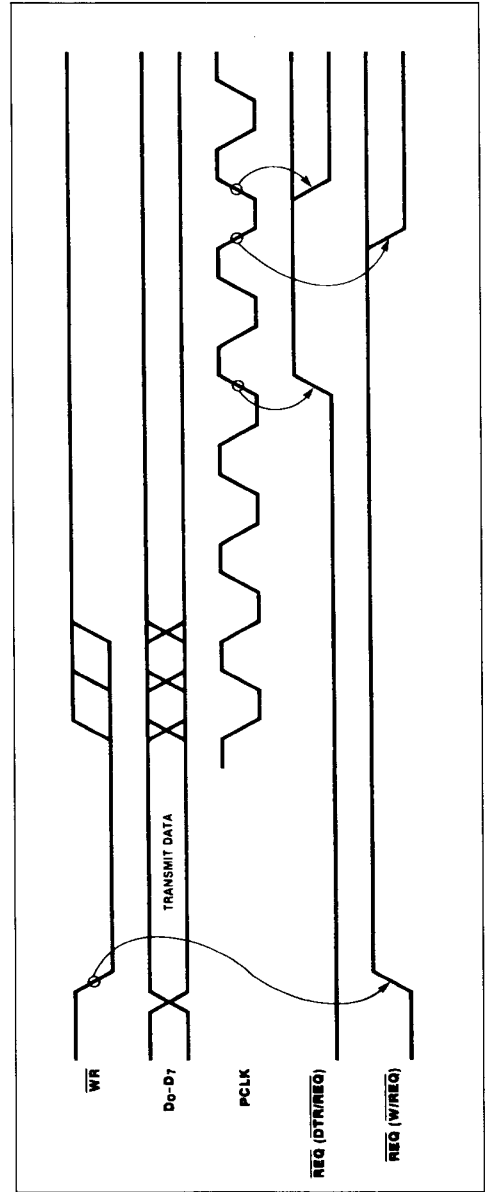

Figure 21 : Transmit Request Release.



I/O PROGRAMMING CAPABILITIES (cont'd)

Figure 22 : Receive Request Assertion.

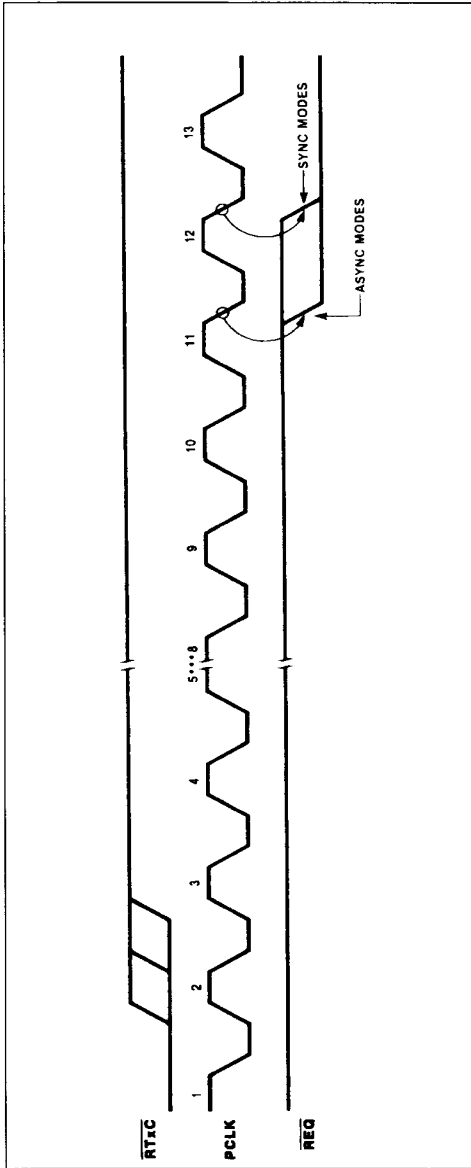
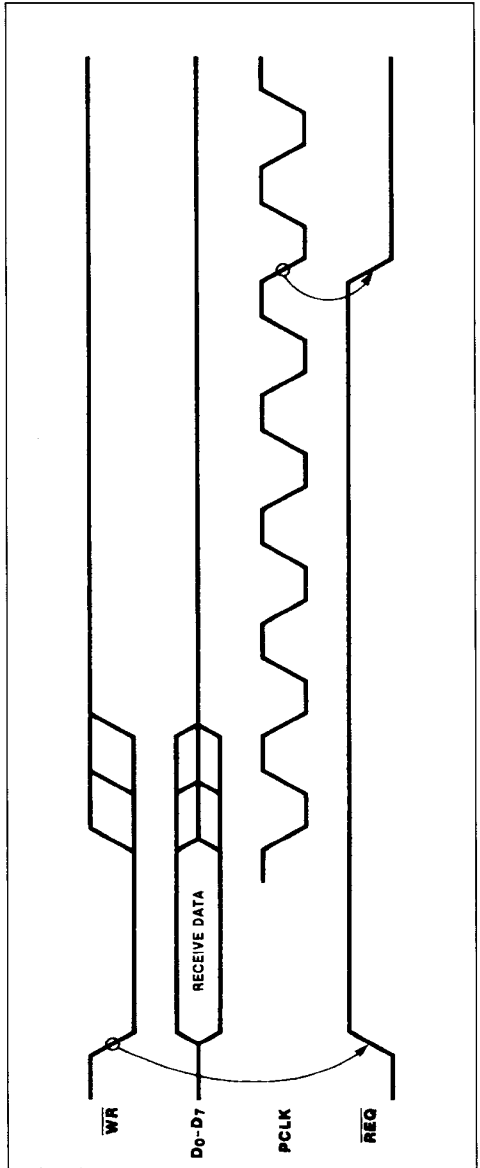

Figure 23 : Z8530 Receive Request Release.



PROGRAMMING DATA COMMUNICATION MODES

The SCC provides two independent full-duplex channels programmable for use in any common asynchronous or synchronous data communication protocol. These include asynchronous, synchronous byte-oriented protocols, monosync, IBM Bisync, and bit-oriented protocols such as HDLC and SDLC. This chapter is divided into 3 parts : Asynchronous, Synchronous, and SDLC.

Asynchronous Mode

The SCC supports Asynchronous mode with a number of programmable options including the number of bits per character, the number of stop bits, the clock factor, modem interface signals and break detect and generation. Asynchronous mode is selected by programming the desired number of stop bits in D₃ and D₂ of WR4. Programming these two bits with other than "00" places both the receiver and transmitter in Asynchronous mode. In this mode, the SCC ignores the state of bits D₄, D₃, D₂, and D₁ of WR3, bits D₅ and D₄ of WR4, bits D₂ and D₀ of WR5, all of WR6 and WR7 and all of WR10 except D₆ and D₅. Bits that are ignored may be programmed with "1" or "0" or not at all.

Asynchronous Receive. Asynchronous mode is selected by specifying the number of stop bits per character in WR4. This selection applies only the transmitter, however, as the receiver always checks for one stop bit. If after character assembly the receiver finds this stop bit to be a "0", the Framing Error bit in the receive error FIFO is set at the same time that the character is transferred to the receive data FIFO. This error bit accompanies the data to the top of the FIFO, where it generates a special receive condition. The Framing Error bit is not latched, and so must be read in RR1 before the accompanying data is read.

The number of bits per character is controlled by bits D₇ and D₆ of WR3. Five, six, seven, or eight bits per character may be selected via these two bits. Data is right-justified with the unused bits set to "1s". An additional bit, carrying parity information may be selected by setting bit D₀ of WR4 to "1". Note that this also enables parity for the transmitter. The parity sense is selected by bit D₁ of WR4. If this bit is set to "1", the received character is checked for even parity, if set to "0", the received character is checked for odd parity. The additional parity bit per character is transferred to the receive data FIFO along with the data if the data plus parity is eight bits or less. The parity Error bit in the receive error FIFO may be programmed to cause a special receive condition interrupt by setting bit D₂ of WR1 to

"1". This error bit is latched and so will remain active, once set, until an Error Reset command has been issued. If interrupts are not used to transfer data, the Parity Error, Framing Error, and Overrun Error bits in RR1 should be checked before the data is removed from the receive data FIFO.

The break condition is continuous "0s", as opposed to the usual continuous ones during an idle. The SCC recognizes the Break condition upon seeing a null character (all "0s") plus a framing error. Upon recognizing this sequence the Break bit in RR0 will be set and will remain set until a "1" is received. At this point the break condition is no longer present. At the termination of a break the receive data FIFO contains a single null character, which should be read and discarded. The Framing Error bit will not be set for this character, but if odd parity has been selected, the Parity Error bit will be set. Caution should be exercised if the receive data line contains a switch that is not debounced to generate breaks. Switch bounce may cause multiple breaks, recognized by the SCC to be additional characters assembled in the receive data FIFO. It may also cause a receive overrun condition being latched.

The SCC may be programmed to accept a receive clock that is one, sixteen, thirty-two, or sixty-four times the data rate. This is selected by bits D₇ and D₆ in WR4. The 1X mode is used when bits are synchronized external to the receiver. The 1X mode is the only mode in which a data encoding method other than NRZ may be used. The clock factor is common to the receiver and transmitter.

The SCC provides up to three modem control signals associated with the receiver. The SYNC pin is a general-purpose input whose state is reported in the Sync/Hunt bit in RR0. If the crystal oscillator is enabled, this pin is not available and the Sync/Hunt bit is forced to "0". Otherwise, the SYNC pin may be used to carry the Ring Indicator signal. The DTR/REQ pin carries the inverted state of the DTR bit (D₇) in WR5 unless this pin has been programmed to carry a DMA Request signal. The DCD pin is ordinarily a simple input to the DCD bit in RR0. However, if the Auto Enables mode is selected by setting D₅ of WR3 to "1", this pin becomes an enable for the receiver. That is, if Auto Enables is on and the DCD pin is HIGH, the receiver is disabled. While the DCD pin is LOW, the receiver is enabled.

The initialization sequence for the receiver in Asynchronous mode is : WR4 first to select the mode, then WR3 and WR5 to select the various options. At this point, the other registers should be ini-

PROGRAMMING DATA COMMUNICATION MODES (cont'd)

tialized as necessary. When all of this is complete the receiver may be enabled by setting bit D₀ or WR3 to "1".

Asynchronous Transmit. Asynchronous mode is selected by specifying the number of stop bits per character in bits D₃ and D₂ of WR4. The three options available are one, one-and-a-half, or two stop bits per character. These two bits only select the number of stop bits for the transmitter, as the receiver always checks for one stop bit.

The number of bits per transmitted character is controlled both by Bits D₆ and D₅ in WR5 and the way the data is formatted within the transmit buffer. The bits in WR5 allow the option of five, six seven, or eight bits per character. When five bits per character is selected the data may be formatted before being written to the transmit buffer to allow transmission of from one to five bits per character.

This formatting is shown in Table 5.

Table 5 : Data Format - Five Bits or Less.

D ₇	D ₆	D ₅	D ₄	D ₃	D ₂	D ₁	D ₀	
1	1	1	1	0	0	0	0	One data bit
1	1	1	0	0	0	0	0	Two data bits
1	1	0	0	0	0	0	0	Three data bits
1	0	0	0	0	0	0	0	Four data bits
0	0	0	0	0	0	0	0	Five data bits

In all cases the data must be right-justified, with the unused bits being ignored except in the case of five bits per character. An additional bit, carrying parity information, may be automatically appended to every transmitted character by setting bit D₀ of WR4 to "1". This bit is sent in addition to the number of bits specified in WR4 or by the data format. The parity sense is selected by bit D₁ of WR4. If this bit is set to "1", the transmitter sends even parity, if set to "0", the parity is odd.

The transmitter may be programmed to send a Break by setting bit D₄ of WR5 to "1". The transmitter will send continuous "0s" from the first transmit clock edge after this command is issued, until the first transmit clock edge after this bit is reset. The transmit clock edges referred to here are those that define transmitted bit cell boundaries.

An additional status bit for use in Asynchronous mode is available in bit D₀ or RR1. This bit, called All Sent, is set when the transmitter is completely empty and any previous data or stop bits have reached the TxD pin. The All Sent bit can be used by

the processor as an indication that the transmitter may be safely disabled.

The SCC may be programmed to accept a transmit clock that is one, sixteen, thirty-two, or sixty-four times the data rate. This is selected by bits D₇ and D₆ of WR4, in common with the clock factor for the receiver. Note that the chosen clock factor may restrict the number of stop bits that may be transmitted. In particular, when the clock rate and data rate are identical, one-and-a-half stop bits are not allowed. If any length other than one stop bit is desired in the times one mode, only two stop bits may be used.

There are two modem control signals associated with the transmitter provided by the SCC. The RTS pin is a simple output that carries the inverted state of the RTS bit (D₁) in WR5, unless the Auto Enables bit (D₅) is set in WR3. When Auto Enables is set the RTS pin will immediately go LOW when the RTS bit is set. However, when the RTS bit is reset the RTS pin remains LOW until the transmitter is completely empty and the last stop bit has left the TxD pin. Thus the RTS pin may be used to disable external drivers for the transmit data. The CTS pin is ordinarily a simple input to the CTS bit in RR0. However, if Auto Enables mode is selected this pin becomes an enable for the transmitter. That is, if Auto Enables is on and the CTS pin is HIGH, the transmitter is disabled; the transmitter is enabled while the CTS pin is LOW.

The initialization sequence for the transmitter in Asynchronous mode is : WR4 first to select the mode, then WR3 and WR5 to select the various options. At this point the other registers should be initialized as necessary. When all of this is complete, the transmitter may be enabled by setting bit D₃ of WR5 to "1". Note that the transmitter and receiver may be initialized at the same time.

Synchronous Mode

In synchronous modes of operation a special bit pattern is used to provide character synchronization. The SCC offers several options to support Synchronous mode including various sync character lengths, the number of bits per data character, parity generation and checking, CRC generation and checking, as well as modem controls and a transmitter to receiver synchronization function. Synchronous mode is selected by programming bits D₃ and D₂ of WR4 with "0s". This selects Synchronous mode, as opposed to Asynchronous mode, but this selection is further modified by bits D₅ and D₇ of WR4 as well as bits D₁ and D₀ of WR10.

PROGRAMMING DATA COMMUNICATION MODES (cont'd)

The sync character or characters are written in WR6 and WR7. In all synchronous modes, except External Sync the state of bits D₇ and D₆ of WR4 are forced to "0" to select the times one clock mode. In External Sync mode these two bits must be programmed with "0s".

Synchronous Receive. The receiver in the SCC searches for character synchronization only while it is in Hunt mode. In this mode the receiver is idle except that it is searching the incoming data stream for a sync character match. The receiver is in Hunt mode when it is first enabled, and may be placed in Hunt mode by command from the processor. This is accomplished by issuing the Enter Hunt Mode command in WR3. This bit (D₄) is a command ; writing a "0" to it has no effect. The Hunt status of the receiver is reported by the Sync/ Hunt bit in RR0. Sync/Hunt is one of the possible sources of external/status interrupts, with both transitions causing an interrupt. This is true even if the Sync/ Hunt bit is set as a result of the processor issuing the Enter Hunt Mode command.

An 8-bit sync character is selected by setting bits D₅ and D₄ of WR4, as well as bit D0 of WR10, to "0". With this option the receiver searches the data stream for a match will the eight bits in WR7. The 6-bit sync option requires the same programming except that D0 of WR10 is set to "1" and the sync character is held in the high-order six bits of WR7. The SCC also allows the option of double length sync characters. This is selected by setting bit D₅ of WR4 to "0" and bit D₄ of WR4 to "1". The selection between 12 and 16 bits of sync character is controlled by bit D0 of WR10. A "0" selects 16 bits of sync character, while a "1" in this bit selects a 12-bit sync character. The arrangement of the sync character in WR6 and WR7 is shown in Figure 24. For those applications requiring any other sync character length, the SCC makes provision for an external circuit to provide a character synchronization signal on the SYNC pin. This mode is selected by setting bit D₅ and D₄ of WR4 to "1". In this mode the Sync/Hunt bit in RR0 reports the state of the SYNC pin but the receiver must still be placed in Hunt mode when the external logic is searching for a sync character match. When the receiver is in Hunt mode and the SYNC pin is driven LOW, two receive clock cycles after the last bit of the sync character is received, character assembly will begin on the rising edge of the receive clock immediately preceding the activation of SYNC. This is shown in Figure 25. The receiver leaves Hunt mode when SYNC is driven LOW. In all cases except External Sync mode the SYNC pin is an output that is driven LOW by the SCC to

signal that a sync character has been received. The SYNC pin is activated regardless of character boundaries so any external circuitry using it should only respond the SYNC pulse that occurs while the receiver is in Hunt mode. The timing for the SYNC signal is shown in Figure 26.

The number of bits per character is controlled by bits D₇ and D₆ of WR3. Five, six, seven, or eight bits per character may be selected via these two bits. The data is right-justified in the receive data buffer. The SCC merely takes a snapshot of the receive data stream at the appropriate times so the "unused" bits in the receive buffer are only the bits following the character in the data stream. An additional bit, carrying parity information, may be selected by setting bit D₀ of WR4 to "1". If this bit is set to "1", the received character is checked for even parity, if set to "0", the received character is checked for odd parity. The additional bit per character is visible in the receive data FIFO if the data plus parity is eight bits or less. The parity bit is not visible when there are eight data bits per character. The Parity Error bit in the receive error FIFO may be programmed to cause a Special Receive Condition interrupt by setting bit D₂ of WR1 to "1". This error bit is latched and so will remain active, once set, until an Error Reset command has been issued. If interrupts are not used to transfer data the Parity Error, CRC Error, and Overrun Error bits in RR1 should be checked before the data is removed from the receive data FIFO. The character length may be changed at any time before the new number of bits has been assembled by the receiver, but, care should be exercised as unexpected results may occur. A representative example, switching from five bits to eight bits and back to five bits is shown in Figure 27. It is sometimes desirable to prevent sync characters in the receive data stream from being transferred to the receive data FIFO. This function is available in the SCC by setting the Sync Character Load Inhibit bit (D₁) in WR3 to "1". While this bit is set to "1", character about to be loaded into the receive data FIFO is compared with the contents of WR6. If all eight bits match the character, it is not loaded into the receive data FIFO. Because the comparison is across eight bits, this function works correctly only when the number of bits per character is the same as the sync character length. Thus it cannot be used with 12- or 16-bit sync characters. Both leading sync characters and sync characters embedded in the data will be properly removed in the case of an 8-bit sync character, but only the leading sync characters may be properly removed in the case of a 6-bit sync character. Care must be exercised in using this feature be-

PROGRAMMING DATA COMMUNICATION MODES (cont'd)

cause sync characters not transferred to the receive data FIFO will automatically be excluded from CRC calculation. This works properly only in the 8-bit case.

Either of two CRC polynomials may be used in synchronous modes, selected by bit D₂ in WR5. If this bit is set to "1", the CRC-16 polynomial is used, if this bit is set to "0", the CRC-CCITT polynomial is used. This bit controls the polynomial selection for both the receiver and transmitter. The initial state of the generator and checker is controlled by bit D₇ of WR10. When this bit is set to "1", both the generator and checker will have an initial value of all ones, if this bit is set to "0", the initial values will be all "0s". The SCC presets the checker whenever the receiver is in Hunt mode so a CRC reset command is not strictly necessary. However, the CRC checker may be preset by issuing the Reset CRC Checker command in WR0. This command is encoded in bits D₇

and D₆ of WR0. If CRC is to be used the CRC checker must be enabled by setting bit D₀ of WR3 to "1". If sync characters are being stripped from the data stream, this may be done at any time before the first non-sync character is received. If the sync strip feature is not being used, CRC must not be enabled until after the first data character has been transferred to the receive data FIFO. As previously mentioned, 8-bit sync characters stripped from the data stream are automatically excluded from CRC calculation.

Some synchronous protocols require that certain characters be excluded from CRC calculation. This is possible in the SCC because CRC calculation may be enabled and disabled on the fly. To give the processor sufficient time to decide whether or not a particular character should be included in the CRC calculation, the SCC contains an 8-bit time delay between the receive shift register and the CRC

Figure 24 : Sync Character Programming.

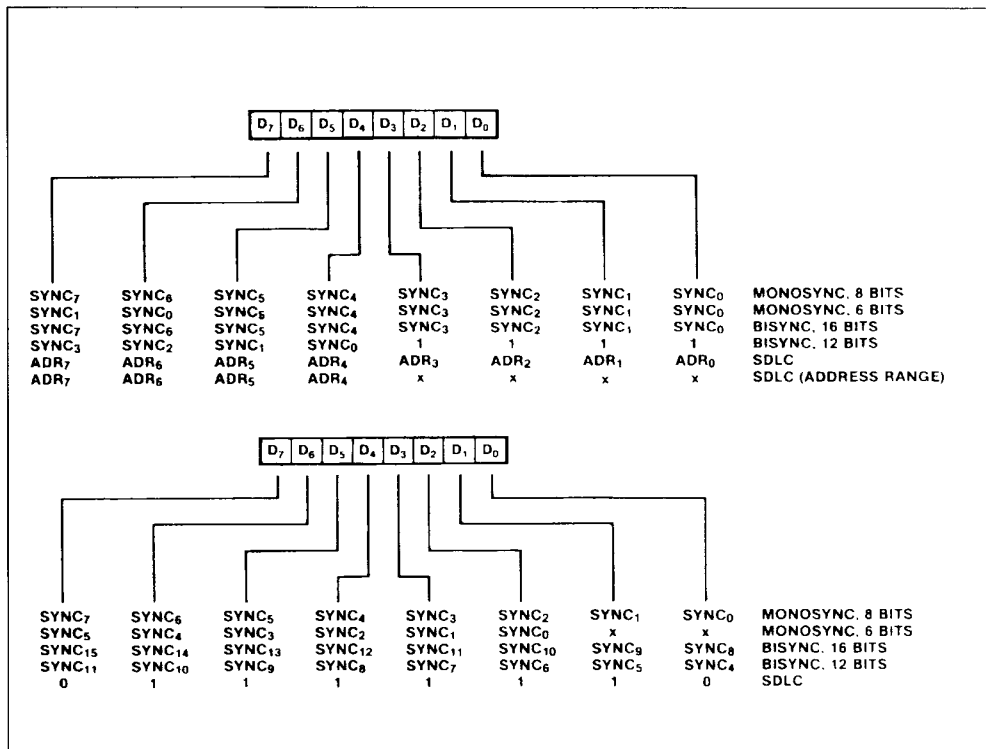

PROGRAMMING DATA COMMUNICATION MODES (cont'd)

Figure 25 : SYNC as an Output.

Figure 26 : SYNC as an Input.

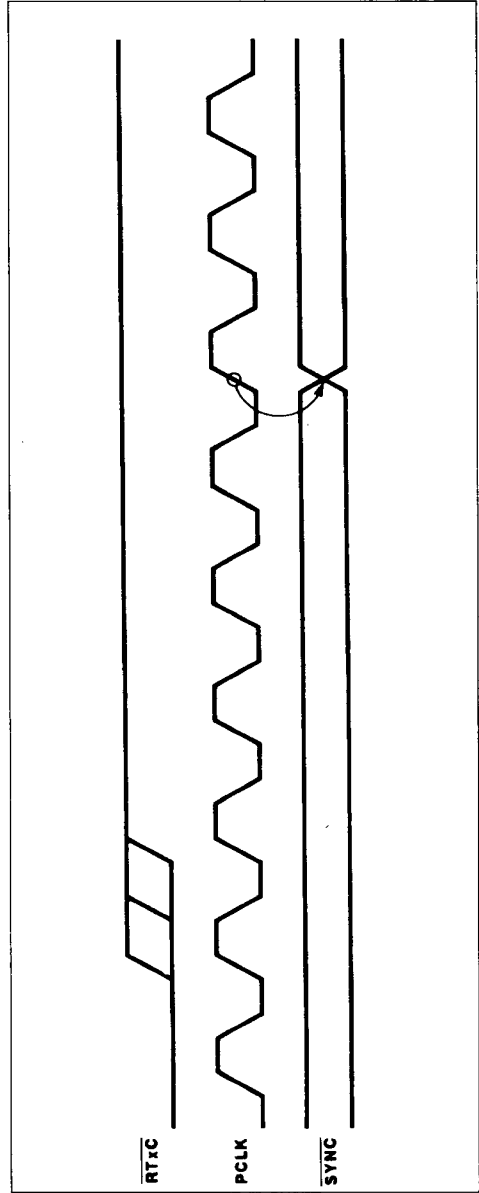
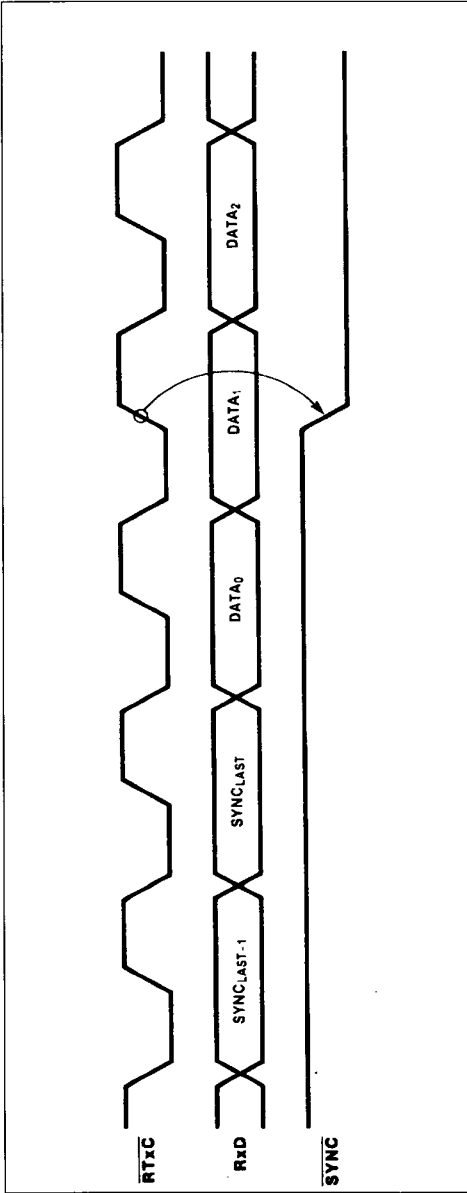

PROGRAMMING DATA COMMUNICATION MODES (cont'd)

checker. The logic also guarantees that the calculation will only start or stop on a character boundary by delaying the enable or disable until the next character is loaded into the receive data FIFO. To understand how this works refer to Figure 28 and the following explanation. Consider a case where the SCC receives a sequence of eight bytes, called A, B, C, D, E, F, G and H with A receiver first. Now suppose that A is the sync character, that CRC is to be calculated on B, C, E, and F, and that F is the last byte of this message. Before A is received the receiver is in Hunt mode and the CRC is disabled. When A is in the receive shift register it is compared with the contents of WR7. Since A is the sync character, the bit patterns match and receiver leaves Hunt mode, but character A is not transferred to the receive data FIFO. The CRC remains disabled even though somewhere during the next eight-bit-time processor reads B and enables CRC. At the end of

an eight-bit-time, B is in the 8-bit delay and C is in the receive shift register. At this point, B is loaded into the receive data FIFO. The CRC remains disabled even though somewhere during the next eight bit times the processor reads B and enables CRC. At the end of the eight-bit-time, B is in the 8-bit delay and C is in the receive shift register. Character C is loaded into the receive data FIFO and at the same time the CRC checker is enabled. During the next eight-bit-time, the processor reads C and leaves the CRC enabled. At the end of these eight-bit-times the SCC has calculated CRC on B, character C is the 8-bit delay and D is in the Receive Shift register. D is then loaded into the receive data buffer and at some point during the next eight-bit-time the processor reads D and disables CRC. At the end of these eight-bit-times CRC has been calculated on C, character D is in the 8-bit delay and E is in the Receive Shift register.

Figure 27 : Changing Character Length.

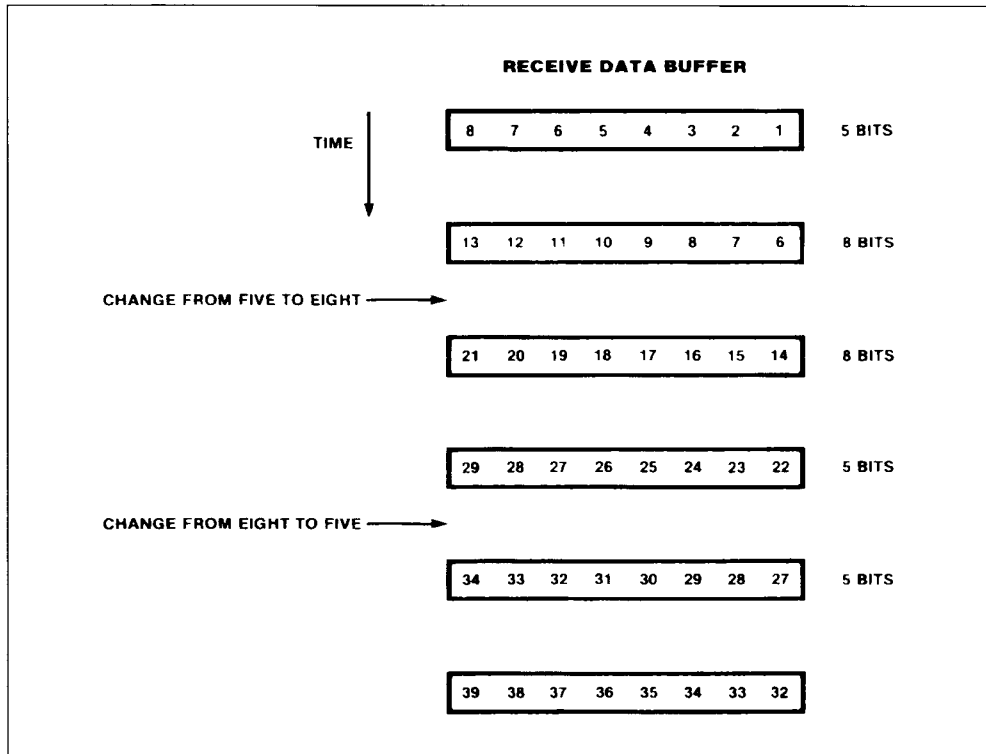

PROGRAMMING DATA COMMUNICATION MODES (cont'd)

Now E is loaded into the receiver data FIFO and, at the same time, the CRC is disabled. During the next eight-bit-times the processor reads E and enables the CRC. During this time E shifts into the 8-bit delay, F enters the Receive Shift register and CRC is not being calculated on D. After these eight-bit-times have elapsed, E is in the 8-bit delay, and F is in the Receive Shift register. Now F is transferred to the receive data FIFO and CRC is enabled. During the next eight-bit-times the processor reads F and leaves the CRC enabled. The processor is usually aware that this is the last character in the message and so prepares to check the result of the CRC computation. However, another sixteen bit-times are required before CRC has been calculated on all of character F. At the end of eight-bit-times F is in the 8-bit delay and G is in the Receive Shift register. At this time G is transferred to the receive data FIFO. Character G must be read and discarded by the processor. Eight bit times later H is transferred to the receive data FIFO also. The result of a CRC calculation is latched in the receive error FIFO at the same time as data is written to the receive data FIFO. Thus the CRC result through character F accompanies

character H in the FIFO and will be valid in RR1 until character H is read from the receive data FIFO. The CRC checker may be disabled and reset at any time after character H is transferred to the receive data FIFO. Recall, however, that internally CRC will not be disabled until a character is loaded into the receive data FIFO so the reset command should not be issued until after this occurs. A better alternative is to place the receiver in Hunt mode, which automatically disables and resets the CRC checker.

Up to two modem control signals associated with the receiver are available in synchronous modes. The DTR REQ pin carries the inverted state of the DTR bit (D7) in WR5 unless this pin has been programmed to carry a DMA Request signal. The DCD pin is ordinarily a simple input to the DCD bit in RR0. However, if the Auto Enables mode is selected by setting D5 of WR3 to "1", this pin becomes an enable for the receiver. That is, if Auto Enables is on and the DCD pin is HIGH the receiver is disabled; while the DCD pin is LOW the receiver is enabled.

The initialization sequence for the receiver in synchronous modes is WR4 first, to select the mode,

Figure 28 : Receive CRC Data Path.

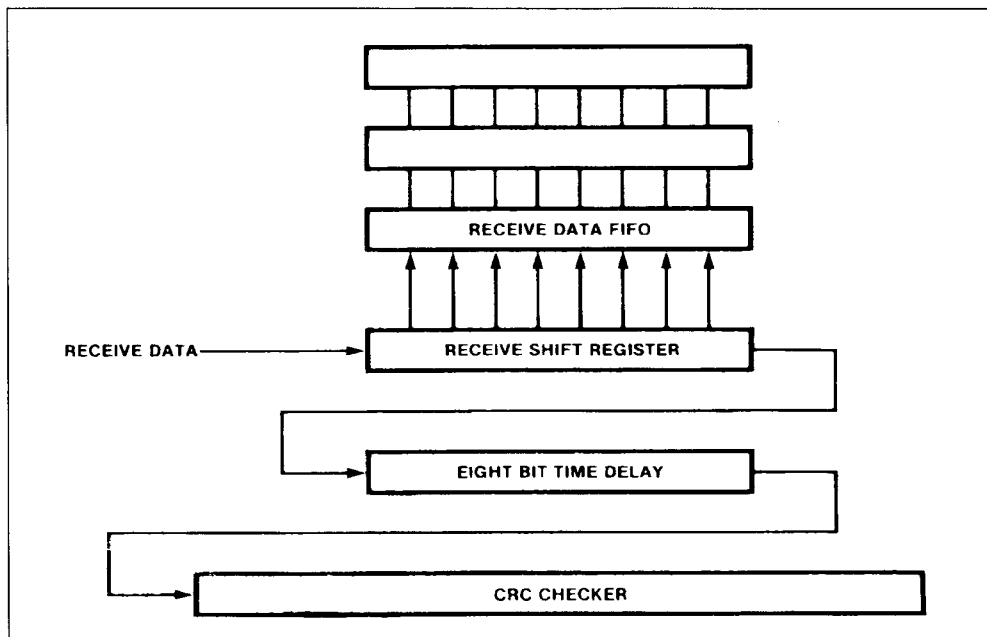

PROGRAMMING DATA COMMUNICATION MODES (cont'd)

then WR10 to modify it if necessary, WR6 and WR7 to program the sync characters and then WR3 and WR5 to select the various options. At this point the other registers should be initialized as necessary. When all of this is complete the receiver is enabled by setting bit D of WR3 to "1".

Synchronous Transmit. Once Synchronous mode has been selected, any of three sync character lengths may be selected. An 8-bit sync character is selected by setting bits D₅ and D₄ of WR4, as well as bit D₀ of WR10 to "0". With this option selected the transmitter sends the contents of WR6 when it has no data to send. The 6-bit sync option requires the same programming except that bit D₀ of WR10 is set to "1" and only the least significant six bits of WR6 and used as a time fill. For a 16-bit sync character, set bit D₄ of WR4 to "1" and D₅ of WR4 and bit D₀ of WR10 to "0". In this mode the transmitter sends the concatenation of WR6 and WR7 as a time fill. Because the receiver requires that sync characters be left-justified in the registers, while the transmitter requires them to be right-justified, only the receiver will work with a 12-bit sync character. While the receiver is in External Sync mode the transmitter sync length may be six or eight bits, as selected by bit D₀ of WR10.

The number of bits per transmitted character is controlled by bits D₆ and D₅ of WR5 and the way the data is formatted within the transmit buffer. The bits in WR5 allow the option of five, six, seven, or eight bits per character. When five bits per character is selected the data may be formatted before being written to the transmit buffer to allow transmission of from one to five bits per character. This formatting is shown in Table 5. In all cases the data must be right-justified, with the unused bits being ignored except in the case of five bits per character. An additional bit, carrying parity information, may be automatically appended to every transmitted character by setting bit D₀ of WR4 to "1". This parity bit is sent in addition to the number of bits specified in WR4 or by the data format. If this bit is set to "1", the transmitter will send even parity, if set to "0", the transmitted parity will be odd.

Either of two CRC polynomials may be used in synchronous modes, selected by bit D₂ in WR5. If this bit is set to "1", the CRC-16 polynomial is used and, if this bit is set to "0", the CRC-CCITT polynomial is used. This bit controls the selection for both the transmitter and receiver. The initial state of the generator and checker is controlled by bit D₇ of WR10. When this bit is set to "1", both the generator and checker will have an initial value of all ones, if this

bit is set to "0", the initial values will be all zeros. The SCC does not automatically preset the CRC generator, so this must be done in software. This is accomplished by issuing the Reset Tx CRC Generator command, which is encoded in bits D₇ and D₆ of WR0. For proper results this command must be issued while the transmitter is enabled and sending sync characters. If CRC is to be used, the transmit CRC generator must be enabled by setting bit D₀ of WR5 to "1". This bit may also be used to exclude certain characters from the CRC calculation. Sync characters are automatically excluded from the CRC calculation and any characters written as data may also be excluded from the calculation by using bit D₀ of WR5. Internally, the CRC is enabled or disabled for a particular character at the same time as the character is loaded from the transmit buffer to the Transmit Shift register. Thus, to exclude a character from CRC calculation bit, D₀ of WR5 should be set to "0" before the character is written to the transmit buffer. This guarantees that the internal disable will occur when the character moves from the buffer to the shift register. Once the buffer becomes empty, the Tx CRC Enable bit may be written for the next character.

Enabling the CRC generator is not sufficient to control the transmission of CRC. In the SCC this function is controlled by the Tx Underrun/EOM bit, which may be reset by the processor and set by the SCC. When the transmitter underruns (both the transmit buffer and Transmit Shift register are empty) the state of the Tx Underrun/EOM bit determines the action taken by the SCC. If the tx Underrun/EOM bit is set when the underrun occurs, the transmitter will send sync characters, if this bit is reset when the underrun occurs, the transmitter will send the accumulated CRC followed by sync characters. When the CRC is loaded into the transmit Shift register for transmission, the SCC will set the Tx Underrun/EOM bit to indicate this. This transition may be programmed to cause an external/status interrupt, or the Tx Underrun/EOM is available in RR0. The Reset Tx Underrun/EOM Latch command is encoded in bits D₇ and D₆ in WR0. For correct transmission of the CRC at the end of a block of data, this command must be issued after the first character is written to the SCC but before the transmitter underruns after the last character written to the SCC. The command is usually issued immediately after the first character is written to the SCC so that CRC will be sent if an underrun occurs inadvertently during the block of data.

In synchronous modes, if the transmitter is disabled during transmission of a character, that character

PROGRAMMING DATA COMMUNICATION MODES (cont'd)

will be sent completely. This applies to both data and sync characters. However, if the transmitter is disabled during the transmission of CRC, the 16-bit transmission will be completed, but the remaining bits will come from the SYNC registers rather than the remainder of the CRC.

There are two modem control signals associated with the transmitter provided by the SCC. The RTS pin is a simple output that carries the inverted state of the RTS bit (D₁) in WR5. The CTS pin is ordinarily a simple input to the CTS bit in RR0. However, if Auto Enables mode is selected this pin becomes an enable for the transmitter. That is, if Auto Enables is on and the CTS pin is HIGH the transmitter is disabled. While the CTS pin is LOW, transmitter is enabled.

The initialization sequence for the transmitter in synchronous modes is : WR4 first, to select the mode, then WR10 to modify it if necessary, WR6 and WR7 to program the sync characters, then WR3 and WR5 to program the sync characters, and then WR3 and WR5 to select the various options. At this point, the other registers should be initialized as necessary. When all of this is complete the transmitter may be enabled by setting bit D₃ or WR5 to "1". Now that the transmitter is enabled the CRC generator may be initialized by issuing the Reset Tx CRC Generator command in WR0.

Transmitter To Receiver Synchronization. The SCC contains a transmitter-to-receiver synchronization function that may be used to guarantee that

the character boundaries for the received and transmitted data are the same. In this mode the receiver is in Hunt and the transmitter is idle, sending either all "1s" or "0s". When the receiver recognizes a sync character, it leaves Hunt mode and one character time later the transmitter is enabled and begins sending sync characters. Beyond this point the receiver and transmitter are again completely independent, except that the character boundaries are now aligned. This is shown in Figure 29. There are several restrictions on the use of this feature in the SCC. First, it will only work with 6-bit, 8-bit or 16-bit sync characters, and the data character length for both the receiver and the transmitter must be six bits with a 6-bit sync character or eight bits with an 8-bit or 16-bit sync character. Of course, the receive and transmit clocks must have the same rate as well as the proper phase relationship.

A specific sequence of operations must be followed to synchronize the transmitter to the receiver. Both the receiver and transmitter must have been initialized for operation in Synchronous mode sometime in the past, although this initialization need not be redone each time the transmitter is synchronized to the receiver. The transmitter is disabled by setting bit D₃ of WR5 to "0". At this point the transmitter will send continuous "1s". If it is desired that continuous "1s". If it is desired that continuous "0s" be transmitted, the Send Break bit (D₄) in WR5 should be set to "1". The transmitter is now idling but must still be placed in the transmitter to receiver synchronization mode. This is accomplished by setting the Loop

Figure 29 : Transmitter to Receiver Synchronization.

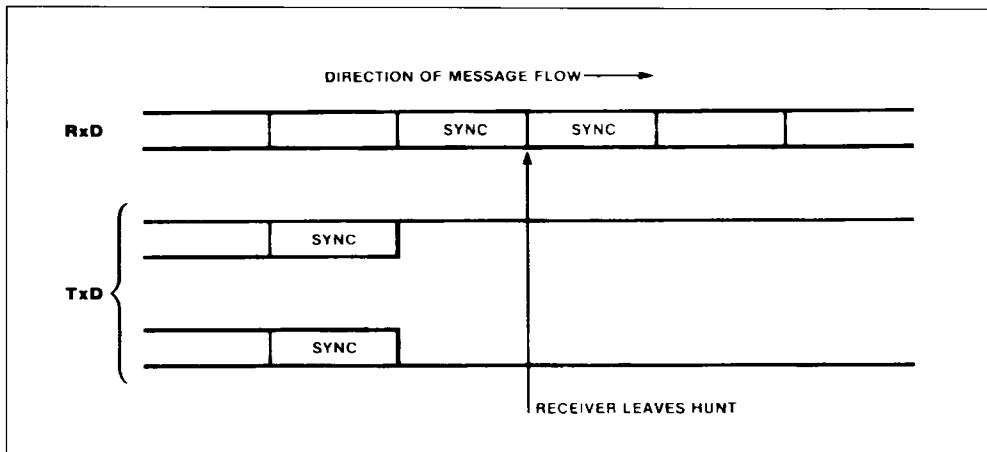

PROGRAMMING DATA COMMUNICATION MODES (cont'd)

the processor should set the Go Active on Poll bit (D₄) in WR10. The final step is to force the receiver to search for sync characters. If the receiver is currently disabled the receiver will enter Hunt mode when it is enabled by setting bit D₀ of WR3 to "1". If the receiver is already enabled it may be placed in Hunt mode by setting bit D₄ of WR3 to "1". Once the receiver leaves Hunt mode the transmitter is activate on the following character boundary.

SDLC Mode

SDLC mode is useful in bit-oriented protocols. That is, protocols which use the technique of "0" insertion to achieve data transparency. In SDLC mode, frames of information are opened and closed by a unique bit pattern called a flag. The Flag character has a bit pattern of "01111110" and this sequence is unique because all data between the opening and closing flags is prohibited from having more than five consecutive "1"s. The transmitter guarantees this by watching the transmit data stream and inserting a "0" after five consecutive ones, irrespective of character boundaries. In turn, the receiver searches the receive data stream for five consecutive "1s" and deletes the next bit if it is a "0". CRC may be used in SDLC mode but only with the CRC-CCITT polynomial, because the transmitter in the SCC automatically inverts the CRC before transmission, and the receiver - to compensate for this - checks the CRC result for the bit pattern "000111010000111". This is consistent with bit-oriented protocols such as SDLC, HDLC, and ADCCP. There are two unique bit patterns in SDLC mode besides the flag sequence. They are the Abort and EOP (End of Poll) sequence. An Abort is a sequence of from seven to thirteen consecutive "1s" and is used to signal the premature termination of a frame. The EOP is the bit pattern "11111110", which is used in loop applications as a signal to a secondary station that it may begin transmission.

SDLC mode is selected by setting bit D₅ of WR4 to "1" and bits D₄, D₃, and D₂ of WR4 to "0". In addition, the flag sequence must be written to WR7. Additional control bits for SDLC mode are located in WR10.

SDLC Receive. The receiver in the SCC always searches the receive data stream for flag characters in SDLC mode. Ordinarily, the receiver transfers all received data between flags to the receive data FIFO. However, if the receiver is in Hunt mode no flag is received. The receiver is in Hunt mode when first enabled, or the receiver may be placed in Hunt mode by the processor issuing the Enter Hunt mode command in WR3. This bit (D₄) is a command, and writing a "0" to it has no effect. The Hunt status of the receiver is reported by the Sync/Hunt bit in RR0. Sync/Hunt is one of the possible sources of external/status interrupts, with both transitions causing an interrupt. This is true even if the Sync/Hunt bit is set as a result of the processor issuing the Enter Hunt mode command. The receiver will automatically enter Hunt mode if an abort is received. Because the receiver always searches the receive data stream for flags and automatically enter Hunt Mode when an abort is received, the receiver will always handle frames correctly, and the Enter Hunt Mode command should never be needed. The SCC will drive the SYNC pin LOW to signal that a flag has been recognized. The timing for the SYNC signal is shown in Figure 30.

The first byte in an SDLC frame is assumed by the SCC to be the address of the secondary station for which the frame is intended. The SCC provides several options for handling this address. If the Address Search Mode bit (D₂) in WR3 is set to "0", the address recognition logic is disabled and all received frames are transferred to the receive data FIFO. In this mode the software must perform any address recognition. If the Address Search Mode bit is

Table 6 : Residue Codes.

Residue Code			Bits in Previous Byte				Bits in Second Previous Byte				Bits in Third Previous Byte			
2	1	0	8 B/C	7 B/C	6 B/C	5 B/C	8 B/C	7 B/C	6 B/C	5 B/C	8 B/C	7 B/C	6 B/C	5 B/C
1	0	0	0	0	0	0	3	1	0	0	8	7	5	2
0	1	0	0	0	0	0	4	2	0	0	8	7	6	3
1	1	0	0	0	0	0	5	3	1	0	8	7	6	4
0	0	1	0	0	0	0	6	4	2	0	8	7	6	5
1	0	1	0	0	0	0	7	5	3	1	8	7	6	5
0	1	1	0	0	0	-	8	6	4	-	8	7	6	-
1	1	1	1	0	-	-	8	7	-	-	8	7	-	-
0	0	0	2	-	-	-	8	-	-	-	8	-	-	-

PROGRAMMING DATA COMMUNICATION MODES (cont'd)

set to "1", only those frames whose address matches the address programmed in WR6 or the global address (all "1s") will be transferred to the receive data FIFO. The address comparison will be across all eight bits of WR6 if the Sync Character Load Inhibit bit (D₁) in WR3 is set to "0". The comparison may be modified so that only the four most significant bits of WR6 must match the received address. This mode is selected by setting the Sync Character Load Inhibit bit to "1". In this mode, however, the address field is still eight bits wide. The address field is transferred to the receive data FIFO in the same manner as data. It is not treated differently than data.

The number of bits per character is controlled by bits D₇ and D₆ of WR3. Five, six, seven, or eight bits per character may be selected via these two bits. The data is right-justified in the receive buffer. The SCC merely takes a snapshot of the receive data stream at the appropriate times, so the "unused" bits in the receive buffer are only the bits following the character in the data stream. An additional bit carrying parity information may be selected by setting bit D₆ of WR4 to "1". This also enables parity in the transmitter. The parity sense is selected by bit D₁ of WR4. Parity is not normally used in SDLC mode. The character length may be changed at any time before the new number of bits have been assembled by the receiver. Care should be exercised, however, as unexpected results may occur. A representative example, switching from five bits to eight bits and back to five bits is shown in Figure 31.

Most bit-oriented protocols allow an arbitrary number of bits between opening and closing Flags. The SCC allows for this by providing three bits of Residue Code in RR1 that indicate which bits in the last few bytes transferred from the receive data FIFO by the processor are actually valid data bits. The meaning of these three bits with each character length option is shown in Table 6. As indicated in the table, these bits allow the processor to determine those bits in the information (and not CRC) field. This allows transparent retransmission of the received frame. The Residue Code bits do not go through a FIFO so they change in RR1 when the last character of the frame is loaded into the receive data FIFO. If there are any characters already in the receive data FIFO the Residue Code will be updated before they are read by the processor. Thus these three bits off RR1 should be ignored by the processor unless the End of Frame bit in RR1 is set.

Only the CRC-CCITT polynomial may be used for CRC calculation in SDLC mode, although the gene-

Figure 30 : SYNC as an Output.

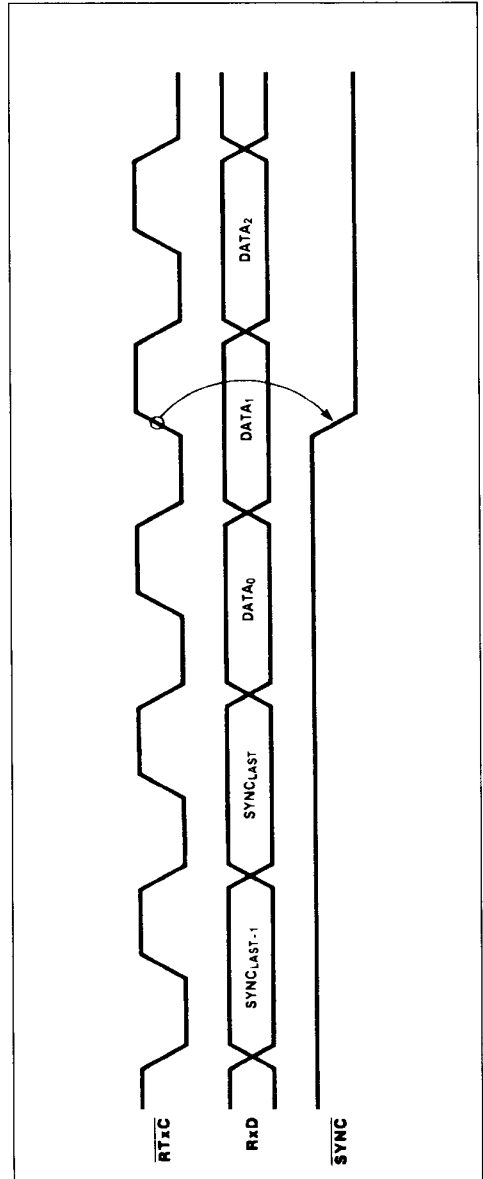

PROGRAMMING DATA COMMUNICATION MODES (cont'd)

rator and checker may be preset to all "1s" or all "0s". The CRC-CCITT polynomial is selected by setting D₂ of WR5 to "0", bit D₇ of WR10 controls the preset value. If this bit is set to "1", the generator and checker are preset to "1s", if this bit is reset, the generator and checker are preset to all "0s". The receiver expects the CRC to be inverted before transmission and so checks the CRC result against the value "0001110100001111". The SCC presets the CRC checker whenever the receiver is in Hunt mode or whenever a flag is received so a CRC reset command is not strictly necessary. However, the CRC checker may be preset by issuing the Reset CRC Checker command in WRO. The CRC checker is automatically enabled for all data between the opening and closing flags by the SCC in SDLC mode, and the Rx CRC Enable bit (D₃) in WR3 is ignored. The result of the CRC calculation for the entire frame is valid in RR1 only when accompanied by the end of Frame bit being set in RR1. At all other times the CRC Error bit in RR1 should be ignored by the processor. Care must be exercised so that the processor does not attempt to use the CRC bytes that are

transferred as data because not all of the bits are transferred properly. The last two bits of CRC are never transferred to the receive data FIFO and are not recoverable.

A frame is terminated by a closing flag. When the SCC recognizes this flag the contents of the Receive Shift register are transferred to the receive data FIFO, the Residue Code is latched, the CRC Error bit is latched in the status FIFO and the End Of Frame bit is set in the receive status FIFO. The End Of Frame bit, upon reaching the top of the FIFO, will cause a special receive condition. The processor may then read RR1 to determine the result of the CRC calculation as well as the Residue Code. If either the Rx Interrupt on Special Condition Only or the Rx Interrupt on First Character or Special Condition mode are selected, the processor must issue an Error Reset command in WRO to unlock the receive FIFO.

In addition to searching the data stream for flags, the receiver in the SCC also watches for seven consecutive "1s", which is the abort condition. The

Figure 31 : Changing Character Length.

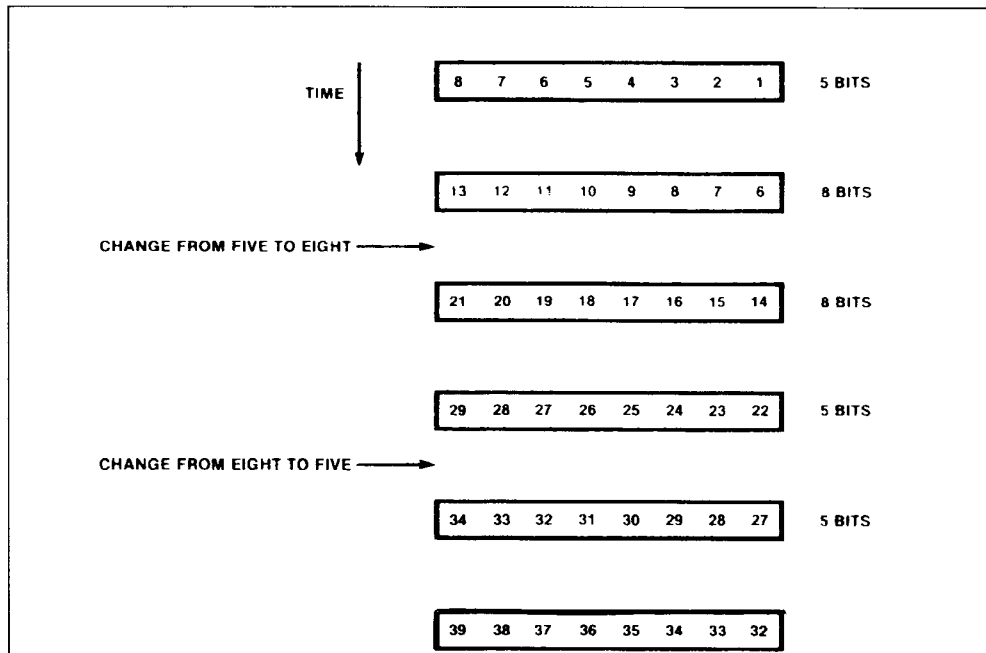

PROGRAMMING DATA COMMUNICATION MODES (cont'd)

presence of seven consecutive "1s" is reported in the Break/Abort bit in RR0. This is one of the possible external/status interrupts, so transitions of this status may be programmed to cause interrupts. Upon receipt of an abort the receiver is forced into Hunt mode, where it looks for flags. The Hunt status is also a possible external/status condition whose transition may be programmed to cause an interrupt. The transitions of these two bits occur very close together but either one or two external/status interrupts may result. The abort condition is terminated when a "0" is received, either by itself or as the leading "0" of a flag. The receiver does not leave Hunt mode until a flag has been received so two discrete external/status conditions will occur at the end of an abort. An abort received in the middle of a frame terminates the frame reception, but no in an orderly manner, because the character being assembled is lost.

Up to two modem control signals associated with the receiver are available in SDLC mode. The DTR/REQ pin carries the inverted state of the DTR bit (D7) in WR5 unless this pin has been programmed to carry a DMA Request signal. The DCD pin is ordinarily a simple input to the DCD bit in RR0. However, if the Auto Enables mode is selected by setting bit D5 of WR3 to "1", this pin becomes an enable for the receiver. That is, if Auto Enable is on and the DCD pin is HIGH the receiver is disabled. While the DCD pin is LOW, the receiver is enabled.

The initialization sequence for the receiver in SDLC mode is: WR4 first, to select the mode, then WR10 to modify it if necessary, WR6 to program the address, WR7 to program the flag and the WR3 and WR5 to select the various options. At this point the other registers should be initialized as necessary. When all of this is complete the receiver may be enabled by setting bit D6 of WR3 to "1".

SDLC Transmit. Once SDLC mode has been selected, the flag must be written in WR7, to be used to open and close the transmitted frames. The SCC does not automatically send the address byte; it merely encapsulates the data supplied by the processor with flags and CRC. Ordinarily, a frame will be terminated by the SCC with CRC and a flag but the SCC may be programmed to send an abort and a flag in place of the CRC. This option allows the SCC to abort a frame transmission in progress if the transmitter is accidentally allowed to underrun. This is controlled by the Abort/Flag On Underrun bit (D2) in WR10. When this bit is set to "1" the transmitter will send an abort and a flag in place of the CRC when an underrun occurs. The frame will be termi-

nated normally, with CRC and a flag, if this bit is set to "0". The SCC is also able to send an abort by command of the processor. The Send Abort command, issued in WR0, will send eight consecutive "1s" and then the transmitter will idle. Since up to five consecutive "1s" may have been sent prior to the command being issued, a Send Abort will cause a sequence of from eight to thirteen "1s" to be transmitted. The Send Abort command also empties the transmit buffer register. The idle condition for the transmitter is continuous flags, but this is under program control. By setting the Mark/Flag Idle bit (D3) in WR10 to "1", the transmitter will send continuous "1s" in place of the idle flags. Note that the closing flag will be transmitted correctly even if this mode is selected. The Mark/Flag Idle must be set to "0", allowing a flag to be transmitted, before data is written to the transmit buffer. Care must be exercised in doing this because the continuous "1s" are transmitted eight at a time, and all eight must leave the Transmit Shift register, so that flag may be loaded into it before the first data is written to the transmit buffer. When using the transmitter in SDLC mode, recall that all data passes through the zero inserter, which adds an extra five bit times of delay between the Transmit Shift register and the Transmit Data pin.

The number of bits per transmitted character is controlled by bits D6 and D5 of WR5 and the way the data is formatted within the transmit buffer. The bits in WR5 allow the option of five, six, seven, or eight bits per character. When five bits per character is selected, the data may be formatted before being written to the transmit buffer, to allow transmission of one to five bits per character. This formatting is shown in Table 4-1. In all cases the data must be right-justified, with the unused bits being ignored, except in the case of five bits per character.

An additional bit, carrying parity information, may be automatically appended to every transmitted character by setting bit D6 of WR4 to "1". This bit is sent in addition to the number of bits specified in WR4 or by the data format. The parity sense is selected by bit D1 of WR4. Parity is not normally used in SDLC mode. The character length may be changed on the fly, but the desired length must be selected before the character is loaded into the transmit shift register from the transmit buffer. The easiest way to ensure this is to write to WR5 to change the character length before writing the data to the transmit buffer.

Only the CRC-CCITT polynomial may be used in SDLC mode. This is selected by setting bit D2 in WR5 to "0". This bit controls the selection for both

PROGRAMMING DATA COMMUNICATION MODES (cont'd)

the transmitter and receiver. The initial state of the generator and checker is controlled by bit D₇ of WR10. When this bit is set to "1", both the generator and checker will have an initial value of all "1s" and, if this bit is set to "0", the initial values will be all "0s". The SCC does not automatically preset the CRC generator so this must be done in software. This is accomplished by issuing the Reset Tx CRC generator command, which is encoded in bits D₇ and D₆ of WR0. For proper results, this command must be issued while the transmitter is enabled and idling. If CRC is to be used the transmit CRC generator must be enabled by setting bit D₀ of WR5 to "1". CRC is normally calculated on all characters between opening and closing flags, so this bit is usually set to "1" at initialization and never changed.

Enabling the CRC generator is not sufficient to control the transmission of CRC. In the SCC this function is controlled by the Tx Underrun/EOM bit, which may be reset by the processor and set by the SCC. When the transmitter underruns (both the transmit buffer and transmit shift register are empty) the state of the Tx Underrun/EOM bit determines the action taken by the SCC. If the Tx Underrun/EOM bit is set to "1" when the underrun occurs, the transmitter will send flags; if this bit is reset to "0" when the underrun occurs, the transmitter will send either the accumulated CRC followed by flags, or an abort followed by flags, depending on the state of the Abort/Flag on Underrun bit in the WR10. When the CRC or abort is loaded into the Transmit Shift register for transmission, the SCC will set the Tx Underrun/EOM bit to indicate this. This transition may be programmed to cause an external/status interrupt, or the Tx Underrun/EOM bit is available in RR0. The Reset Tx Underrun/EOM Latch command is encoded in bits D₇ and D₆ of WR0.

For correct transmission of the CRC at the end of a frame, this command must be issued after the first character is written to the SCC but before the transmitter underruns after the last character written to the SCC. The command is usually issued immediately after the first character is written to the SCC so that the abort or CRC is sent if an underrun occurs inadvertently. The Abort/Flag on Underrun bit (D₂) in WR10 is usually set to "1" at the same time as the Tx Underrun/EOM bit is reset so that an abort will be sent if the transmitter underruns. The bit is then set to "0" near the end of the frame to allow the correct transmission of CRC.

In this paragraph the term "completely sent" means shifted out of the Transmit Shift register, not shifted out of the zero inserter, which is an additional five

bit times of delay. In SDLC mode, if the transmitter is disabled during transmission of a character, that character will be "completely sent". This applies to both data and flags. However, if the transmitter is disabled during the transmission of CRC, the 16-bit transmission will be completed but the remaining bits will be from the Flag register rather than the remainder of the CRC.

There are two modem control signals associated with the transmitter provided by the SCC. The RTS pin is a simple output that carries the inverted state of the RTS bit (D₁) in WR5. The CTS pin is ordinarily a simple input to the CTS bit in RR0. However, if Auto Enables mode is selected, this pin becomes an enable for the transmitter. That is, if Auto Enables is on and the CTS pin is HIGH the transmitter is disabled. If the CTS pin is LOW, the transmitter is enabled.

The initialization sequence for the transmitter in SDLC mode is: WR4 first, to select the mode, then WR10 to modify it if necessary, WR7 to program the flag, and then WR3 and WR5 to select the various options. At this point the other registers should be initialized as necessary. When all of this is complete, the transmitter may be enabled by setting bit D₃ of WR5 to "1". Now that the transmitter is enabled, the CRC generator may be initialized by issuing the Reset Tx CRC Generator command in WR0.

SDLC Loop Mode. SDLC Loop mode is quite similar to SDLC mode except that two additional control bits are used. They are the Loop Mode bit (D₁) and the Go Active on Poll bit (D₄) in WR10. In addition to these two extra control bits, there are also two status bits in RR10. They are the On Loop bit (D₁) and the Loop Sending bit (D₄). Before Loop mode is selected both the receiver and transmitter must be completely initialized for SDLC operation. Once this is done, Loop mode is selected by setting bit D₁ of WR10 to "1". At this point the SCC connects TxD to RxD with only gate delays in the path. At the same time a flag is loaded into the Transmit Shift register, and is shifted to the end of the zero inserter, ready for transmission. The SCC will remain in this state until the Go Active on Poll bit (D₄) in WR10 is set to "1". When this bit is set to "1" the receiver begins looking for a sequence of seven consecutive "1s", indicating either an EOP or an idle line. When the receiver detects this condition the Break/Abort bit in RR0 is set to "1" and a one-bit time delay is inserted in the path from RxD to TxD. The On Loop bit in RR10 is also set to "1" at this time, and the receiver enters the Hunt mode. The SCC cannot transmit on the loop until a flag is received, causing the receiver

PROGRAMMING DATA COMMUNICATION MODES (cont'd)

to leave Hunt mode, and another EOP (bit pattern "11111110") is received. The SCC is now on the loop and capable of transmitting on the loop. As soon as this status is recognized by the processor, the Go Active On Poll bit in WR10 should be set to "0" to prevent the SCC from transmitting on the loop without the consent of the processor.

To transmit a message on the loop, the Go Active On Poll bit in WR10 must be set to "1". Once this is done, the SCC will change the next received EOP into Flag and begin transmitting on the loop. When the EOP is received, the Break/Abort and Hunt bits in RR0 will be set to "1", and the Loop Sending bit in RR10 will also be set to "1". Data to be transmitted may be written after the Go Active On Poll bit has been set or after the receiver enters Hunt mode. If the data is written immediately after the Go Active On Poll bit has been set, the SCC will only insert one flag after the EOP is changed into a flag. If the data is not written until after the receiver enters the Hunt mode, flags will be transmitted until the data is written. If only one frame is to be transmitted on the loop in response to an EOP, the processor must set the Go Active On Poll bit to "0" before the last data is written to the transmitter. In this case the transmitter will close the frame with a single flag, and then revert to the one-bit delay. The Loop Sending bit in RR10 is set to "0" when the closing Flag has been sent. If more than one frame is to be transmitted, the Go Active On Poll bit should not be set to "0" until the last frame is being sent. If this bit is not set to "0" before the end of a frame, the transmitter will send Flags until either more data is written to the transmitter, or until the Go Active On Poll bit is set to "0". Note that the state of the Abort/Flag on Underrun and Mark/Flag Idle bits in WR10 are ignored by the SCC in SDLC Loop mode.

To go off the loop in an orderly manner requires actions similar to those taken to go the loop. First, the Go Active On Poll bit must be set to "0" and any transmission in progress completed, if the SCC is currently sending on the loop. Once the SCC is not sending on the loop, an exit from the loop is accomplished by setting the Loop Mode bit in WR10 to "0", and at the same time writing the Abort/Flag on Underrun and Mark/Flag Idle bits with the desired va-

lues. The SCC will revert to normal SDLC operation as soon as an EOP is received, or immediately, if the receiver is already in Hunt mode because of the receipt of an EOP.

The initialization sequence for the SCC in SDLC Loop mode is similar to the sequence used in SDLC mode, except that it is somewhat longer. The processor should program WR4 first, to select SDLC mode, and then WR10 to select the CRC preset value and program the Mark/Flag Idle bit. The Loop Mode and Go Active On Poll bits in WR10 should not be set to "1" yet. The flag is written in WR7 and the various options are selected in WR3 and WR5. At this point the other registers should be initialized as necessary, then Loop Mode bit (D₁) in WR10 should be set to "1". When all of this is complete the transmitter may be enabled by setting bit D₃ of WR5 to "1". Now that the transmitter is enabled, the CRC generator may be initialized by issuing the Reset TxCRC Generator command in WR0. The receiver is enabled by setting the Go Active on Poll bit (D₄) in WR10 to "1". The SCC will go on the loop when seven consecutive "1s" are received, and will signal this by setting the On Loop bit in RR10. Note that the seven consecutive "1s" will set the Break/Abort and Hunt bits in RR0 also. Once the SCC is on the loop, the Go Active on Poll bit should be set to "0" until a message is to be transmitted on the loop. To transmit a message on the loop, the Go Active on Poll bit should be set to "1". At this point the processor may either write the first character to the transmit buffer and wait for a transmit buffer empty condition, or wait for the Break/Abort and Hunt bits to be set in RR10 and the Loop Sending bit to be set in RR10 before writing the first data to the transmitter. The Go Active On Poll bit should be set to "0" after the transmission of the frame has begun. To go off of the loop, the processor should set the Go Active On Poll bit in WR10 to "0" and then wait for the Loop Sending bit in RR10 to be set to "0". At this point the Loop Mode bit (D₁) in WR10 is set to "0" to request an orderly exit from the loop. The SCC will exit SDLC Loop mode when seven consecutive "1s" have been received; at the same time the Break/Abort and Hunt bits in RR0 will be set to "1", and the On Loop bit in RR10 will be set to "0".

SUPPORT CIRCUITRY PROGRAMMING

The SCC incorporates additional circuitry to aid in serial communications. This circuitry includes clocking options, baud rate generator, data encoding, and internal loopback. This section discusses how to program these functions.

Clock Options

The SCC may be programmed to select one of several sources to provide the transmit and receive clocks. In addition, the SCC requires a fundamental, parallel resonant crystal oscillator in each channel, as well as the ability to echo one of several internal clock sources to the outside world. These options are controlled by the bits in WR11.

The crystal oscillator option is controlled by bit D₇ in WR11. When this is set to "0", the crystal oscillator is disabled and all pins function normally. When this bit is set to "1" the crystal oscillator is enabled and a high-gain amplifier is connected between the RTxC pin and the SYNC pin. While the crystal oscillator is enabled, anything that has RTxC selected as its clock source will automatically be connected to the output of the crystal oscillator. While the crystal oscillator is enabled, the SYNC pin is obviously unavailable for other use. In synchronous modes no sync pulse is output, and the External Sync mode cannot be selected. In asynchronous modes the state of the Sync/ Hunt bit in RR0 is no longer controlled by the SYNC pin. Instead, the Sync/ Hunt bit is forced to "0". The crystal oscillator requires some finite time to stabilize. The oscillator must be allowed to stabilize before it is used as a clock source.

The source of the receive clock is controlled by bits D₆ and D₅ of WR11. The receive clock may be programmed to come from the RTxC pin, the TRxC pin, the output of the baud rate generator, or the transmit output of the DPLL.

The source of the transmit clock is controlled by bits D₄ and D₃ of WR11. The transmit clock may be programmed to come from the RTxC pin, the TRxC pin, the output of the baud rate generator, or the transmit output of the DPLL.

Ordinarily the TRxC pin is an input, but it becomes an output if this pin has not been selected as the source for the transmitter or the receiver, and bit D₂ of WR11 is set to "1". The selection of the signal provided on the TRxC output pin is controlled by bits D₁ and D₀ of WR11. The TRxC pin may be programmed to provide the output of the crystal oscil-

lator, the output of the baud rate generator, the receive output of the DPLL or the actual transmit clock. If the output of the crystal oscillator is selected but the crystal oscillator has not been enabled the TRxC pin will be driven HIGH. The option of placing the transmit clock signal on the TRxC pin when it is an output allows access to the transmit output of the DPLL.

Figure 32 shows a simplified schematic diagram of the circuitry used in the clock multiplexing. It shows the inputs to the multiplexer section as well as the various signal inversions that occur in the paths to the outputs. Also shown are the edges used by the receiver, transmitter, baud rate generator and DPLL to sample or send data or otherwise change state. For example, the receiver samples data on the falling edge, but since there is an inversion in the clock path between the RTxC pin and the receiver, a rising edge of the RTxC pin samples the data for the receiver.

Selection of the clocking options may be done anywhere in the initialization sequence, but the final values must be selected before the receiver, transmitter, baud rate generator, or DPLL are enabled to prevent problems from arbitrarily narrow clock signals out of the multiplexers. The same is true of the crystal oscillator, in that the output should be allowed to stabilize before it is used as a clock source.

Baud Rate Generator

Figure 33 shows a block diagram of the baud rate generator. It consists of a 16-bit down-counter, two 8-bit time constant registers and an output divide-by-two. The baud rate generator input comes from the output of a two-input multiplexer, the zero count condition is output to the External/ Status Interrupt Section. The baud rate generator may be enabled and disabled by command and is disabled by a hardware reset.

The time constant for the baud rate generator is programmed in WR12 and WR13, with the least-significant byte in WR12. The formulas relating the baud rate to the time constant and vice versa are shown with an example. In these formulas the baud rate generator clock frequency is in Hertz, the desired baud rate in bits/ second and the time constant is dimensionless. The example in Table 7 assumes a 2.4576 MHz clock factor of 16 and shows the time constant for a number of popular baud rates.

SUPPORT CIRCUITRY PROGRAMMING (cont'd)

Time Constant Formulas :

$$\text{Time Constant} = \frac{\text{Clock Frequency}}{2 \bullet (\text{Clock Mode}) \cdot (\text{Baud Rate})} - 2$$

$$\text{Baud Rate} = \frac{\text{Clock Frequency}}{2 \bullet (\text{Clock Mode}) \cdot (\text{Time Const.} + 2)}$$

The clock source for the baud rate generator is selected by bit D₁ of WR14. When this bit is set to "0" the baud rate generator uses the signal on the TxC

Table 7 : Baud Rate Example.

Baud Rate	Divider	
	Decimal	Hex
38400	0	0000H
19200	2	0002H
9600	6	0006H
4800	14	000EH
2400	30	001EH
1200	62	003EH
600	126	007EH
300	254	00FEH
150	510	01FEH

For 2.4576 MHz Clock, X 16 Mode

Figure 32 : Clock Multiplexer.

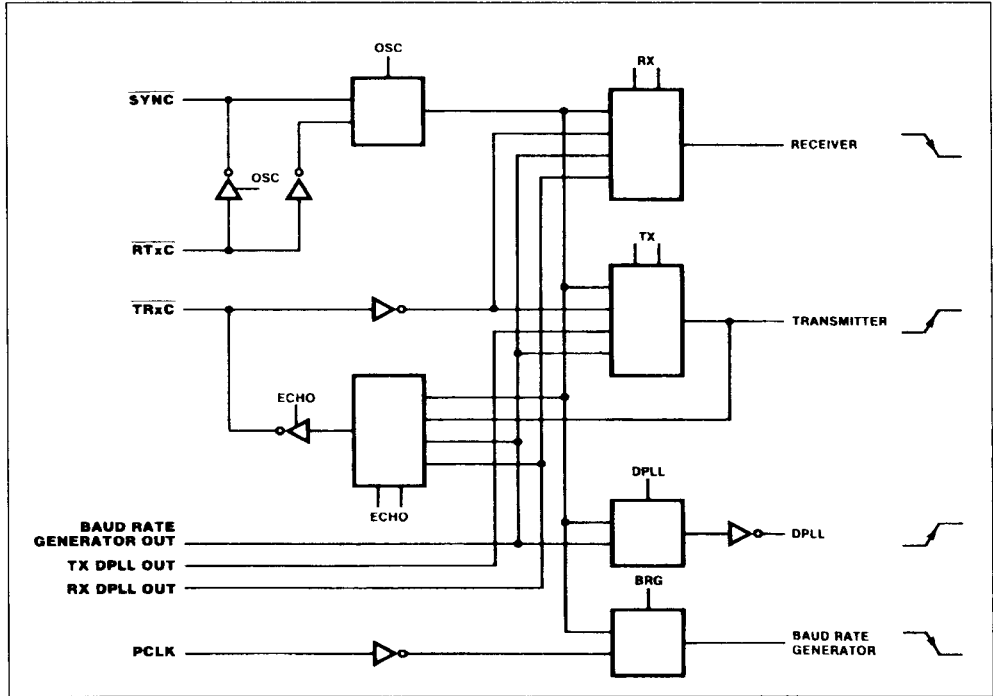

SUPPORT CIRCUITRY PROGRAMMING (cont'd)

pin as its clock, independent of whether the $\overline{\text{TxC}}$ pin is a simple input or part of the crystal oscillator circuit. When this bit is set to "1" the baud rate generator is clocked by PCLK. To avoid metastable problems in the counter, this bit should be changed on-

ly while the baud rate generator is disabled, since arbitrarily narrow pulses can be generated at the output of the multiplexer when it changes status. The baud rate generator is enabled while bit D_0 of WR14 is set to "1" and is disabled while this bit is

Figure 33 : Baud Rate Generator.

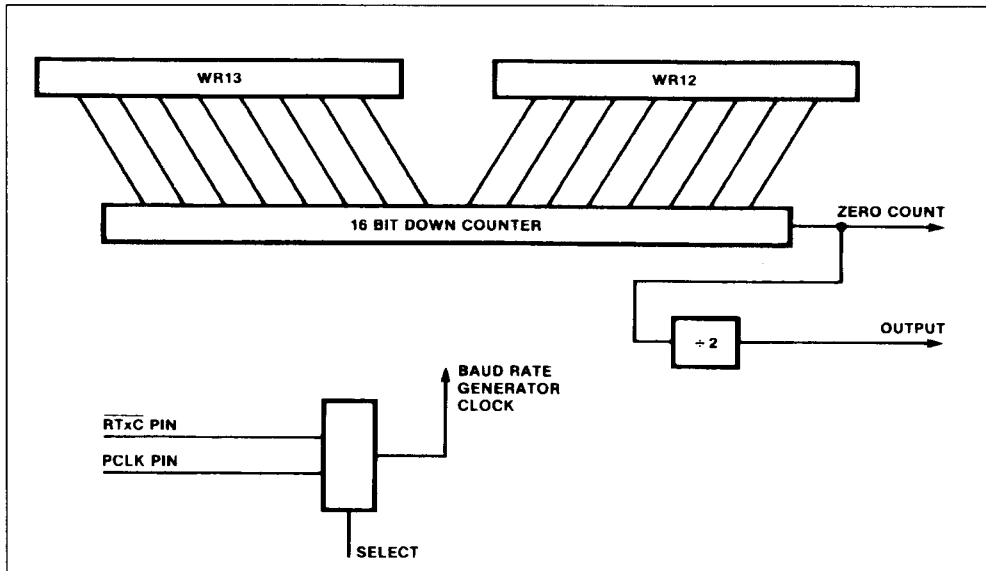
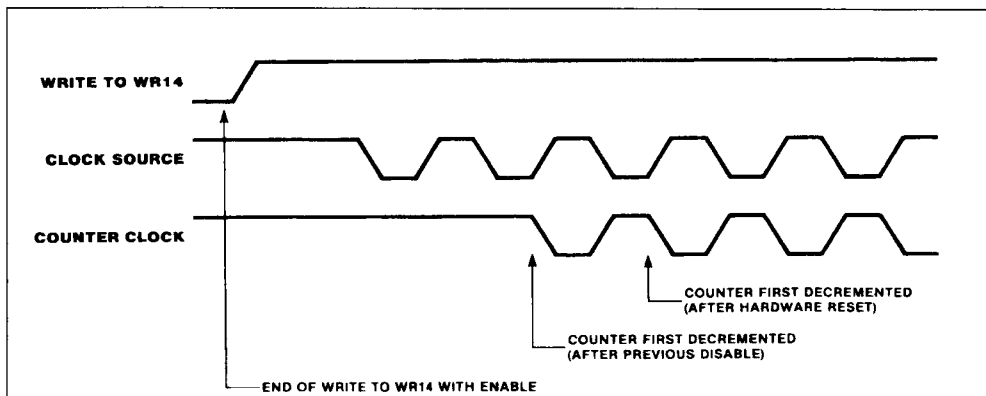

Figure 34 : Baud Rate Generator Start-Up.



SUPPORT CIRCUITRY PROGRAMMING (cont'd)

set to "0". To prevent metastable problems when the baud rate generator is first enabled, the enable bit is synchronized to the baud rate generator clock. This introduces an additional delay then the baud rate generator is first enabled and this is shown in Figure 5-3. The baud rate generator is disabled immediately when bit D0 of WR14 is set to "0", because the delay is only necessary on startup. The baud rate generator may be enabled and disabled on the fly, but this delay on startup must be taken into consideration.

Upon reaching a count of "0" the time constant held in WR12 and WR13 is reloaded into the downcounter so that the process of counting down may start over. In addition to reloading the time constant, the output of the baud rate generator toggles, and for the clock cycle with a zero count, the zero count signal goes active to the External/Status Section. This zero count condition from the baud rate generator does not persist, so if it is to be used by the processor, it should be latched in the External/Status latch. While the baud rate generator is disabled the state of the zero count signal is held. This signal is forced active by a hardware reset.

Initializing the baud rate generator is done in four steps. First, the time constant is determined and loaded into WR12 and WR13. Next, the processor must select the clock source for the baud rate generator by writing to bit D1 of WR14. Finally, the baud rate generator is enabled by setting bit D0 of WR14 to "1". Note that the first write to WR14 is not necessary after a hardware reset if the clock source is to be the RTxC pin. This is because a hardware reset automatically selects the RTxC pin as the baud rate generator clock source.

Data Encoding

The SCC provides four different data encoding methods, selected by bits D6 and D5 in WR10. An example for these four encoding methods is shown in Figure 35. Any encoding method may be used in any X1 mode in the SCC, asynchronous or synchronous. The data encoding selected is active even though the transmitter or receiver may be idling or disabled.

In NRZ encoding a "1" is represented by a HIGH level and a "0" is represented by a LOW level. In this encoding method only a minimal amount of clocking

Figure 35 : Data Encoding Methods.

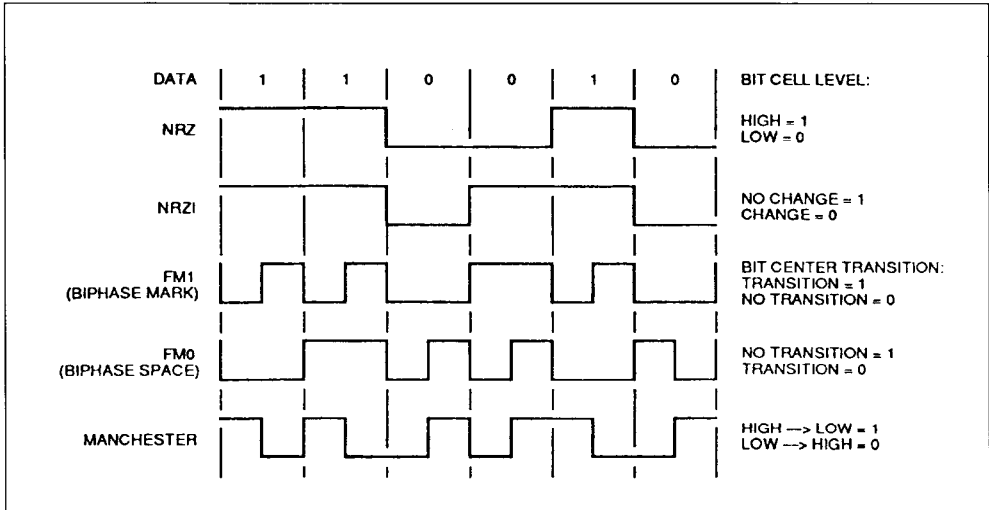

SUPPORT CIRCUITRY PROGRAMMING (cont'd)

information is available in the data stream in the form of transitions on bit-cell boundaries. In an arbitrary data pattern this may not be sufficient to generate a clock for the data from the data itself. In the case of SDLC, where the number of consecutive "1s" in the data stream is limited, a minimum number of transitions to generate a clock are guaranteed.

In FM1 encoding, also known as biphasc mark, a transition is present on every bit cell boundary, and an additional transition may be present in the middle of the bit cell. In FM1 a "0" is sent as no transition in the center of the bit cell and a "1" is sent as a transition in the center of the bit cell. FM1 encoded data contains sufficient information to recover a clock from the data.

In FM0 encoding, also known as biphasc space, a transition is present on every bit cell boundary and an additional transition may be present in the middle on the bit cell. In FM0 a "1" is sent as no transition in the center of the bit cell and a "0" is sent as a transition in the center of the bit cell. FM0 encoded data contains sufficient information to recover a clock from the data.

The data encoding method should be selected in the initialization procedure before the transmitter and receiver are enabled but no other restrictions apply. Note, in Figure 35, that in NRZ and NRZI the receiver samples the data only on one edge. However, in FM1 and FM0 the receiver samples the data on both edges. Also, as shown in Figure 5-4, the transmitter defines bit cell boundaries by one edge in all cases and uses the other edge in FM1 and FM0 to create the mid-bit transition.

Digital Phase-locked Loop

Figure 36 shows a block diagram of the digital phase-locked loop. It consists of a 5-bit counter, an edge detector, and a pair of output decoders. The clock for the DPLL comes from the output of a two-input multiplexer, and the two outputs go to the transmitter and receive clock multiplexers. The

DPLL is controlled by the seven commands that are encoded in bits D₇, D₆ and D₅ of WR14.

The clock for the DPLL is selected by two of the commands in WR14. One command selects the output of the baud rate generator as the clock source, and the other command selects the RTxC pin as the clock source, independent of whether the RTxC pin is a simple input or part of the crystal oscillator circuit. To avoid metastable problems in the counter, the clock source selection should be made only while DPLL is disabled, since arbitrarily narrow pulses can be generated at the output of the multiplexer when it changes status.

The DPLL is enabled by issuing the Enter Search Mode command in WR14. This command is also used to reset the DPLL to a known state if it is suspected that synchronization has been lost. When used to enable the DPLL, the Enter Search Mode command unlocks the counter, which is held while the DPLL is disabled and enables the edge detector. If the DPLL is already enabled when this command is issued, the DPLL also enters Search Mode. While in Search mode, the counter is held at a specific count and no outputs are provided. The DPLL remains in this status until an edge is detected in the receive data stream. This first edge is assumed to occur on a bit cell boundary, and the DPLL will begin providing an output to the receiver that will properly sample the data. From this point on the DPLL will adjust its output to remain in phase with the receive data. If the first edge that the DPLL sees does not occur on a bit cell boundary, the DPLL will eventually lock on to the receive data but it will take longer to do so.

The DPLL may be programmed to operate in either of two modes, as selected by command in WR14. In the NRZI mode the DPLL clock must be 32 times the data rate. In this mode the transmit and receive clock outputs of the DPLL are identical, and the clocks are phased so that the receiver samples the data in the middle of the bit cell. In NRZ mode the DPLL does not require a transition in every bit cell,

Figure 36 : Digital Phase-Locked Loop.

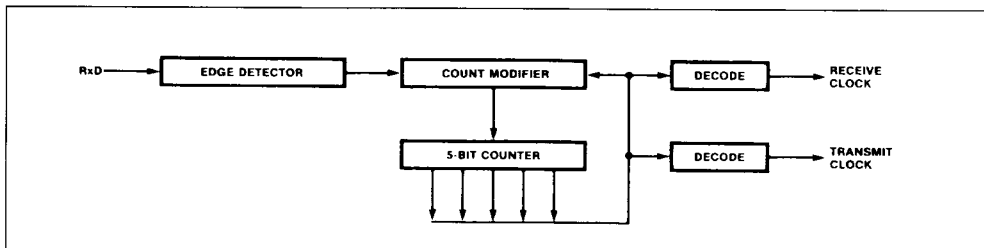

SUPPORT CIRCUITRY PROGRAMMING (cont'd)

so this mode is useful for recovering the clocking information from NRZ and NRZI data streams. In the FM mode the DPLL clock must be 16 times the data rate. In this mode the transmit clock output of the DPLL lags the receive clock outputs by 90°, to make the transmit and receive bit cell boundaries the same, because the receiver must sample FM data at one-quarters and three-quarters bit time. In FM mode the DPLL requires a transition in every bit cell, and if this transition is not present in two consecutively sampled bit cells, the DPLL will automatically enter the search mode. As in the case of the clock source selection, the mode of operation should only be changed while the DPLL is disabled to prevent unpredictable results.

NRZI Mode Operation

To operate in NRZI mode the DPLL must be supplied with a clock that is 32 times the data rate. The DPLL uses this clock, along with the receive data,

to construct receive and transmit clock outputs that are phased to properly receive and transmit data. To do this, the DPLL divides each bit cell into four regions, and makes an adjustment to the count cycle of the 5-bit counter dependent upon in which region a transition on the receive data input occurred. This is shown in Figure 37. Ordinarily, a bit cell boundary will occur between count 15 and count 16, and the DPLL output will cause the data to be sampled in the middle of the bit cell. The DPLL actually allows the transition marking a bit cell boundary to occur anywhere during the second half of count 15 or the first half of count 16 without making a correction to its count cycle. However, if the transition marking a bit cell boundary occurs between the middle of count 16 and count 31 the DPLL is sampling the data too early in the bit cell. In response to this the DPLL extends its count by one during the next 0 to 31 counting cycle, which effectively moves the edge of the clock that samples the receive data closer to

Figure 37 : DPLL in NRZI Mode.

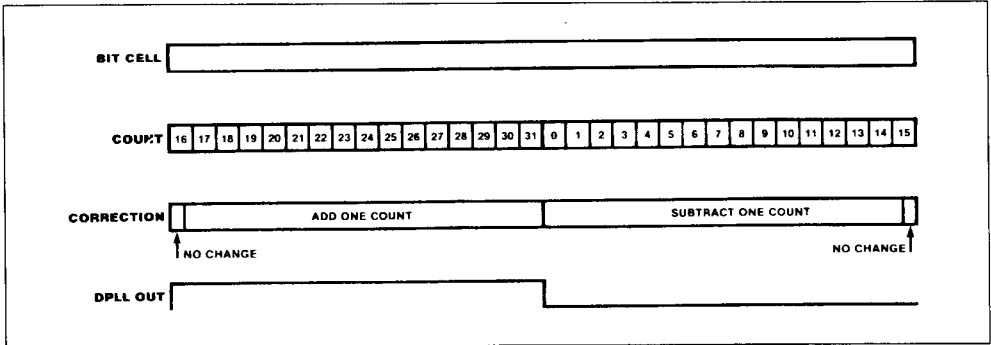
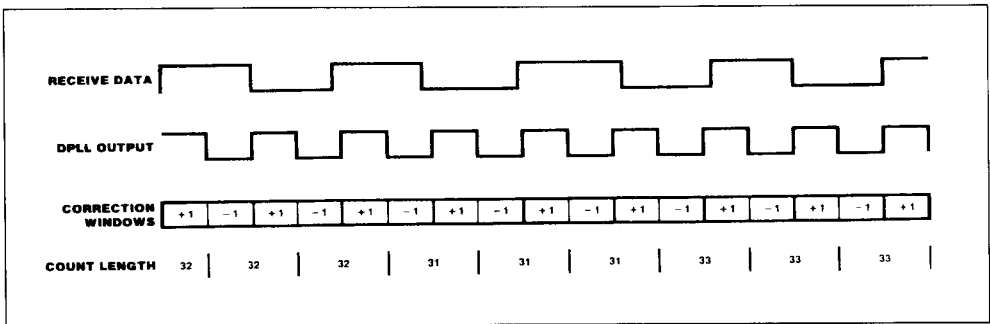

Figure 38 : DPLL Operating Example.



SUPPORT CIRCUITRY PROGRAMMING (cont'd)

the center of the bit cell. In a similar manner, if the transition occurs between count 0 and the middle of count 15, the output of the DPLL is sampling the data too late in the bit cell. To correct this, the DPLL shortens its count by one during the next 0 to 31 counting cycle, which effectively moves the edge of the clock that samples the receive data closer to the center of the bit cell. In NRZI mode, if the DPLL does not see any transition during a counting cycle, no adjustment is made in the following counting cycle. If an adjustment to the counting cycle is necessary the DPLL modifies count five, either deleting it or doubling it. Thus only the LOW time of the DPLL output will be lengthened or shortened. While the DPLL is in search mode, the counter remains at count 16, where the DPLL outputs are both HIGH. The missing clock latches in the DPLL which may be accessed in RR10, are not used in NRZI mode. An example of the DPLL in operation is shown in Figure 38.

FM Mode Operation

To operate in FM mode the DPLL must be supplied with a clock that is 16 times the data rate. The DPLL uses this clock, along with the receive data, to construct receive and transmit clock outputs that are phased to receive and transmit data properly. In FM mode that the counter in the DPLL still counts from 0 to 31 but now each cycle corresponds to 2-bit cells. To make adjustments to remain in phase with the receive data, the DPLL divides a pair of bit cells into five regions, making the adjustment to the coun-

ter dependent upon which region the transition on the receive data input occurred. This is shown in Figure 39. Ordinarily a bit cell boundary will occur between count 15 or count 16, and the DPLL receive output will cause the data to be sampled at one-fourth and three-fourths of the way through the bit cell. The DPLL actually allows the transition marking a bit-cell boundary to occur anywhere during the second half of count 15 or the first half of count 16 without making a correction to its count cycle. However, if the transition marking a bit cell boundary occurs between the middle of count 16 and the middle of count 19 the DPLL is sampling the data too early in the bit cell. In response to this the DPLL extends its count by 1 during the next 0 to 31 counting cycle, which effectively moves the receive clock edges closer to where they should be. In FM mode any transitions occurring between the middle of count 19 in one cycle and the middle of count 12 during the next cycle are ignored by the DPLL. This is necessary to guarantee that any data transitions in the bit cells will not cause an adjustment to the counting cycle.

In FM mode the transmit clock and receive clock outputs from the DPLL are not in phase. This is necessary to make the transmit and receive bit cell boundaries coincide, since the receive clock must sample the data one-fourth and three-fourths of the way through the bit cell. As in NRZI mode, if an adjustment to the counting cycle is necessary, the DPLL

Figure 39 : DPLL in FM Mode.

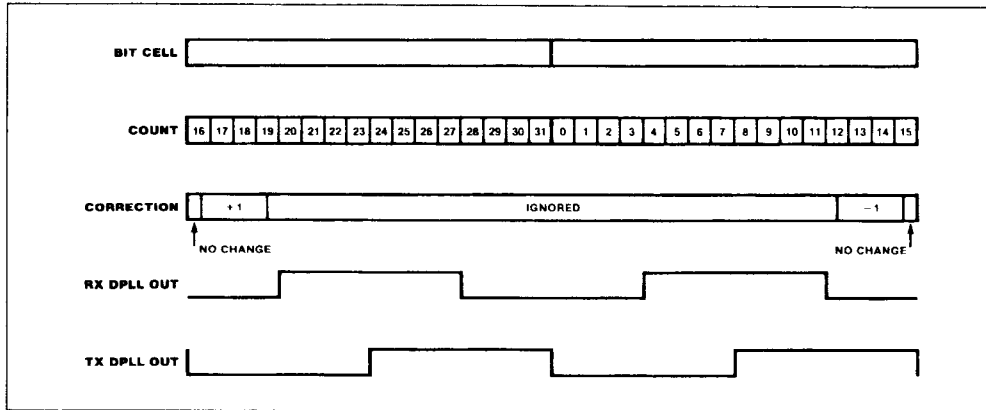

SUPPORT CIRCUITRY PROGRAMMING (cont'd)

modifies count 5, either deleting it or doubling it. If no adjustment is necessary, the count sequence proceeds normally. While the DPLL is in search mode, the counter remains at count 16, where the receive output is LOW and the transmit output is LOW. This fact can be used to provide a transmit clock under software control since the DPLL is in search mode while it is disabled. While the DPLL is disabled the transmit clock output of the DPLL may be toggled by alternately selecting FM and NRZI mode in the DPLL. The same is true of the receive clock.

In addition to FM encoded data, the DPLL may also be used to recover the clock from Manchester encoded data, which contains a transition at the center of every bit cell. Here it is the direction of the transition that distinguishes a "1" from a "0". Another way of looking at Manchester encoding is to realize that, during the first half of the bit cell the data is sent, during the second half of the bit cell the complement of the data is sent. This is shown in Figure 40, along with the DPLL output if it thinks that the mid-bit transitions are really bit cell boundaries. As is obvious from the figure, if the receiver samples the data on the falling edge of the DPLL receive clock output, the Manchester data will be properly decoded. This occurs if the receiver is programmed to accept NRZ data.

From the above discussion together with an examination of FM0 and FM1 data encoding, it should be obvious that only clock transitions should exist on the receive data pin when the DPLL is programmed to enter search mode. If this is not case the DPLL may attempt to lock on to the data transitions. With FM0 encoding this requires continuous "1s" received when leaving search. In FM1 encoding it is continuous "0s"; which Manchester encoded data this means alternating "1s" and "0s". With all three of these data encoding methods there will always be at least one transition in every bit cell, and in FM

mode the DPLL is designed to expect this transition. In particular, if no transition occurs between the middle of count 12 and the middle of count 19, the DPLL is probably not locked onto the data properly. When the DPLL misses an edge the One Clock Missing bit in RR10 is set to "1" and latched. It will hold this value until a Reset Mission Clock command is issued in WR14 or until the DPLL is disabled or programmed to enter the Search mode. Upon missing this one edge the DPLL takes no other action and does not modify its count during the next counting cycle. However, if the DPLL does not see an edge between the middle of count 12 and the middle of count 19 in two successive 0 to 31 count cycles, a line error condition is assumed. If this occurs, the two Clocks Missing bit in RR10 is set to "1" and latched. At the same time the DPLL enters the Search mode. The DPLL makes the decision to enter Search mode during count 2, where both the receive clock and transmit clock outputs are LOW. This prevents any glitches on the clock outputs when search mode is entered. While in search mode no clock outputs are provided by the DPLL. The Two Clocks Missing bit in RR10 is latched until a Reset Missing Clock command is issued in WR14, or until the DPLL is disabled or programmed to enter the Search mode.

DPLL Initialization

Initialization of the DPLL may be done at any time during the initialization sequence, but should probably be done after the clock modes have been selected in WR11, and before the receiver and transmitter are enabled. When initializing the DPLL the clock source should be selected first, followed by the selection of the operating mode. At this point the DPLL, may be enabled by issuing the Enter Search Mode command in WR14. Note that a channel or hardware reset disables the DPLL, selects the \overline{RTXC} pin as the clock source for the DPLL, and places it in the NRZI mode.

Figure 40 : Manchester Clock Recovery.

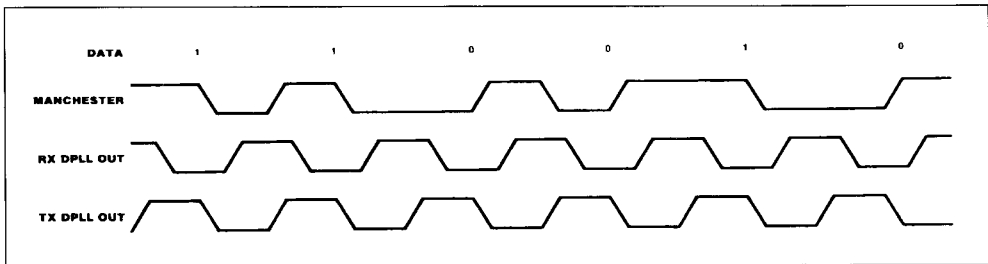

SUPPORT CIRCUITRY PROGRAMMING (cont'd)

Internal Loopback/Auto Echo

The SCC contains two other features useful for diagnostic purposes, controlled by bits in WR14. They are local loopback and auto echo.

Local loopback is selected when bit D4 of WR14 is set to "1". In this mode the output of the transmitter is internally connected to the input of the receiver. At the same time the TxD pin remains connected to the transmitter. In this mode the \overline{DCD} pin is ignored as a receive enable and the CTS pin is ignored as a transmitter enable even if the Auto Enables mode has been selected. Note that the DPLL input is connected to the RxD pin, not to the input of the receiver. This precludes the use of the DPLL in local loopback.

Auto echo is selected when bit D3 of WR14 is set to "1". In this mode the TxD pin is connected directly to the RxD pin, and the receiver input is connected to the RxD pin. In this mode the \overline{CTS} pin is ignored as a transmitter enable and the output of the transmitter does not connect to anything. If both the Local Loopback and Auto Echo bits are set to "1", the auto echo mode will be selected, but both the \overline{CTS} pin and \overline{DCD} pin will be ignored as auto enables. This, however, should not be considered a normal operating mode, however. Local Loopback is shown schematically in Figure 41 and auto echo is shown schematically in Figure 42.

Figure 41 : Local Loopback.

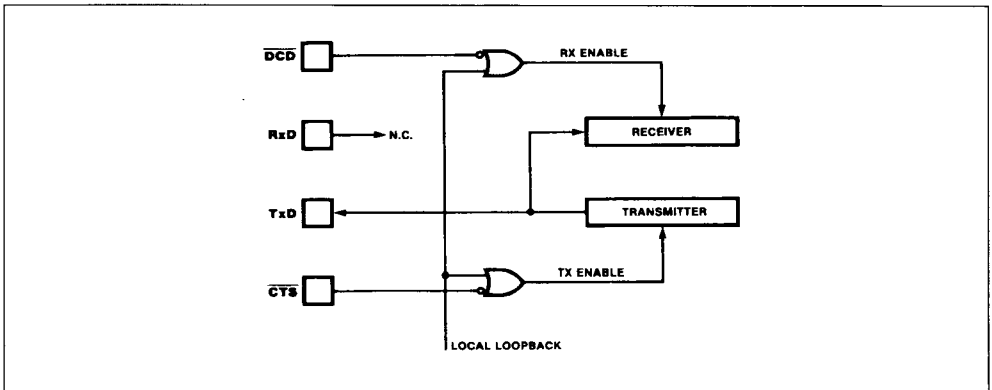
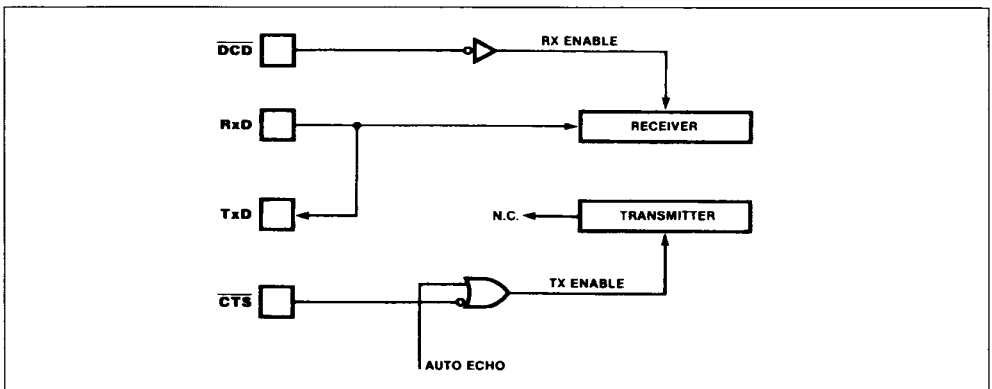

Figure 42 : Auto Echo.



REGISTERS DESCRIPTION

The following section describes the SCC registers. Each register is detailed in terms of bit configuration, the active states (See Table 8) of each bit, their definitions, their functions, and their effects upon the internal hardware and external pins.

Table 8 : SCC Registers Description.

Read Register	Description
RR0	Xmit/Receive Buffer Status and Ext Status
RR1	Receive Condition Status/Residue Codes
RR2	Interrupt Vector (modified in BChannel)
RR3	Interrupt Pending (Channel Aonly)
RR8	Receive Buffer
RR10	Loop/Clock Status
RR12	Lower Byte of Time Constant
RR13	Upper Byte of Time Constant
RR15	External Status Interrupt Enable
Write Register	Description
WR0	Command Register
WR1	Tx/Rx Interrupt and Data Xfer Mode Definition
WR2	Interrupt Vector
WR3	Receive Parameters and Control
WR4	Tx/Rx Miscellaneous Parameters and Modes
WR5	Transmit Parameter and Controls
WR6	Sync Character or SDLC Address Field
WR7	Sync Character or SDLC Flag
WR8	Transmit Buffer
WR9	Master Interrupt Control
WR10	Misc Transmitter/Receiver Control Bits
WR11	Clock Mode Control
WR12	Lower Byte Baud Rate Generator Time Constant
WR13	Upper Byte of Baud Rate Generator Time Constant
WR14	Miscellaneous Control Bits
WR15	External Status/Interrupt Control

WRITE REGISTERS

The SCC write register set in each channel includes ten control registers (among them is the transmit buffer), two sync character registers, and two baud rate time constant registers. The interrupt control register and the master interrupt control and reset register are shared by both channels.

Write Register 0 (command register). WR0 is the command register and the CRC reset code register. Figure 43 shows the bit configuration for the Z8530 and includes register select bits in addition to command and reset codes.

Bits D7 and D6 : CRC Reset Codes 0 And 1

Null Code (00). This command has no effect on the SCC and is used when a write to WR0 is necessary for some reason other than a CRC Reset command.

Reset Receive CRC Checker (01). This command is used to initialize the receive CRC circuitry. It is necessary in synchronous modes (except SDLC) if the Enter Hunt Mode command in Write Register 3 is not issued between received messages. Any action that disables the receiver initializes the CRC circuitry. Resetting the Receive CRC Checker command is accomplished automatically in SDLC mode.

Reset Transmit CRC Generator (10). This command initializes the CRC generator. It is usually issued in the initialization routine and after the CRC has been transmitted. A Channel Reset will not initialize the generator and this command should not be issued until after the transmitter has been enabled in the initialization routine.

Reset Transmit Underrun/EOM Latch (11). This command controls the transmission of CRC at the end of transmission (EOM). If this latch has been reset, and a transmit underrun occurs, the SCC automatically appends CRC to the message. In SDLC mode with Abort on Underrun selected, the SCC sends an abort, and Flag on under-run if the TX Underrun/EOM latch as been reset.

At the start of CRC transmission, the Tx Underrun/EOM latch is set. The Reset command can be issued at any time during a message. If the transmitter is disabled, this command will not reset the latch. However, if no External Status interrupt is pending, or if a Reset External Status Int command accompanies this command while the transmitter is disabled, an External/Status interrupt is generated with the Tx Underrun/ EOM bit reset in RR0.

Bits D5-D3 : Command Codes

Null Code (000). The Null command has no effect on the SCC.

Point High (001). This command effectively adds eight to the Register Pointer (B2-B0) by allowing WR8 through WR15 to be accessed. The Point High command and the Register Pointer bits are written simultaneously.

Reset External/Status Interrupts (010). After an External/Status interrupt (a change on a modem line or a break condition, for example), the status bits in RR0 are latched. This command re-enables the bits and allows interrupts to occur again as a result of a status change. Latching the status bits captures short pulses until the CPU has time to read the change. The SCC contains simple queueing logic associated with most of the external status bits

REGISTERS DESCRIPTION (cont'd)

in RR0. If another External/Status condition changes while a previous condition is still pending (Reset External/Status Interrupts has not yet been issued) and this condition persists until after the command is issued, this second change causes another External/Status interrupt. However, if this second status change does not persist (there are two transitions), another interrupt is not generated. Exceptions to this rule are detailed in the RR0 description.

Figure 43 : Write Register 0 (Z8530).

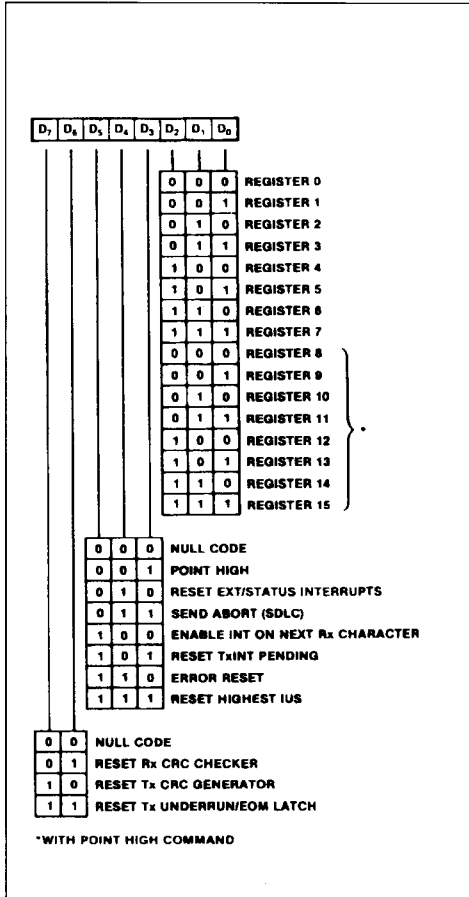

Send Abort (011). This command is used in SDLC mode to transmit a sequence of eight to thirteen "1s". This command always empties the transmit buffer and sets Tx Underrun/EOM bit in Read Register 0.

Enable Interrupt On Next Rx Character (100). If the interrupt on the First Received Character mode is selected, this command is used to reactivate that mode after each message is received. The next character to enter the receive FIFO causes a Receive interrupt. Alternatively, the first previously stored character in the FIFO will cause a Receive interrupt.

Reset Tx Interrupt Pending (101). This command is used in cases where there are no more characters to be sent ; e.g., at the end of a message. This command prevents further transmit interrupts until after the next character has been loaded into the transmit buffer or until CRC has been completely sent. This command is necessary to prevent the transmitter from requesting an interrupt when the transmit buffer becomes empty (with Transmit Interrupt Enabled).

Error Reset (110). This command resets the error bits in RR1. If Interrupt on First Rx Character or Interrupt on Special Condition modes are selected and a special condition exists, the data with the special condition is held in the receive FIFO until this command is issued. If either of these modes is selected and this command is issued before the data has been read from the receive FIFO, the data is lost.

Reset Highest IUS (111). This command resets the highest priority Interrupt Under Service (IUS) bit, allowing lower priority conditions to request interrupts. This command allows the use of the internal daisy chain (even in systems without an external daisy chain) and should be the last operation in an interrupt service routine.

Bits 2 through 0 : Register Selection Code

These three bits select Registers 0 through 7. With the Point High command, Registers 8 through 15 are selected.

The following is a summary of the bit descriptions for each write register (WR1-WR15)

Write Register 1 (transmit/receive interrupt and data transfer mode definition). Write Register 1 is the control register for the various SCC interrupt and Wait/Request modes. Figure 44 shows the bit assignments for WR1.

REGISTERS DESCRIPTION (cont'd)

Bit 7 : WAIT/DMA Request Enable

This bit enables the Wait/Request function in conjunction with the Request/Wait Function Select bit (B6). If bit 7 is set to "1", the state of bit 6 determines the activity of the WAIT/REQUEST pin (Wait or Request). If bit 7 is set to "0", the selected function (bit 6) forces the WAIT/REQUEST pin in to the appropriate inactive state (High for Request, floating for Wait).

Bit 6 : WAIT/DMA Request Function

The request function is selected by setting this bit to "1". In the Request mode, the WAIT/REQUEST pin switches from High to Low when the SCC is ready to transfer data. When this bit is "0", the wait function is selected. In the Wait mode, the WAIT/REQUEST pin switches from floating to Low when the CPU attempts to transfer data before the SCC is ready.

Bit 5 : WAIT/DMA Request On Receive Transmit

This bit determines whether the WAIT/REQUEST pin operates in the Transmit mode or the Receive mode. When set to "1", this bit allows the wait/request function to follow the state of the receive buffer ; i.e., depending on the state of bit 6, the WAIT/REQUEST pin is active or inactive in relation to the empty or full state of the receive buffer. Conversely, if this bit is set to "0", the state of the WAIT/REQUEST pin is determined by bit 6 and the state of the transmit buffer. (Note that a transmit request function is available on the DTR/REQUEST

pin. This allows full-duplex operation under DMA control for both channels.)

The request function may occur only when the SCC is not selected ; e.g., if the internal request becomes active while the SCC is in the middle of a read or write cycle, the external request will not become active until the cycle is complete. An active request output causes a DMA controller to initiate a read or write operation. If the request on Transmit mode is selected in either SDLC or Synchronous Mode, the Request pin is pulsed Low for one PCLK cycle at the end of CRC transmission to allow the immediate transmission of another block of data.

If the Wait On Receive mode, the WAIT pin is active if the CPU attempts to read SCC data that has not yet been received. In the Wait On Transmit mode, the WAIT pin is active if the CPU attempts to write data when the transmit buffer is still full. Both situations can occur frequently when block transfer instructions are used.

Bits 4 and 3 : Receive Interrupt Modes

These two bits specify the various character-available conditions that may cause interrupt requests.

Receive Interrupts Disabled (00). This mode prevents the receiver from requesting an interrupt and is normally used in a polled environment where either the status bits on RR0 or the modified vector in RR2 (Channel B) can be monitored to initiate a service routine. Although the receiver interrupts are disabled, a special condition can still provide a unique vector status in RR2.

Figure 44 : Write Register 1.

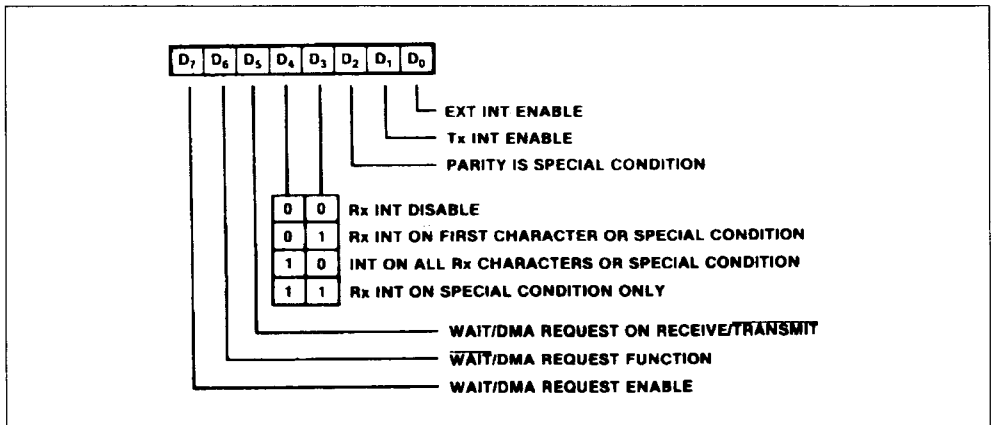

REGISTERS DESCRIPTION (cont'd)

Receive Interrupt On First Character Or Special Condition (01). The receiver requests an interrupt in this mode on the first available character (or stored FIFO character) or on a special condition. Sync characters to be stripped from the message stream do not cause interrupts.

Special receive conditions are : receiver overrun, framing error, end of frame, or parity error (if selected). If a special receive condition occurs, the data containing the error is stored in the receive FIFO until an Error Reset command is issued by the CPU.

This mode is usually selected when a Block Transfer mode is used. In this interrupt mode, a pending special receive condition remains set until either an Error Reset command, a channel or hardware reset, or until receive interrupts are disabled.

The Receive Interrupt on First Character or Special Condition mode can be re-enabled by the Enable Rx Interrupt on Next Character command in WR0.

Interrupt On All Receive Characters Or Special Condition (10). This mode allows an interrupt for every character received (or character in the receive FIFO) and provides a unique vector when a special condition exists. The receiver Overrun bit and the Parity Error bit in RR1 are two special conditions that are latched. These two bits must be reset by the Error Reset command. Receiver overrun is always a special receive condition, and parity can be programmed to be a special condition.

Data characters with special receive conditions are not held in the receive FIFO in the Interrupt On All Receive Characters or Special Conditions Mode as they are in the other receive interrupt modes.

Receive Interrupt On Special Condition (11). This mode allows the receiver to interrupt only on cha-

racters with a special receive condition. When an interrupt occurs, the data containing the error is held in the receive FIFO until an Error Reset command is issued. When using this mode in conjunction with a DMA, the DMA can be initialized and enabled before any characters have been received by the SCC. This eliminates the time critical section of code required in the Receive Interrupt on First Character or Special condition mode ; i.e., all data can be transferred via the DMA so that the CPU need not handle the first received character as a special case.

Bit 2 : Parity Is Special Condition

If this bit is set to "1", any received characters with parity not matching the sense programmed in WR4 give rise to a Special Receive Condition. If parity is disabled (WR4), this bit is ignored. A special condition modifies the status of the interrupt vector stored in WR2. During an interrupt acknowledge cycle, this vector can be placed on the data bus.

Bit 1 : Transmitter Interrupt Enable

If this bit is set to "1", the transmitter requests an interrupt whenever the transmit buffer becomes empty.

Bit 0 : External/Status Master Interrupt Enable

This bit is the master enable for External/Status interrupts including DCD, CTS, SYNC pins, break, abort, the beginning of CRC transmission when the Transmit/Underrun/EOM latch is set, or when the counter in the baud rate generator reaches "0". Write Register 15 contains the individual enable bits for each of these sources of External/Status interrupts. This bit is reset by a channel or hardware reset.

Figure 45 : Write Register 2.

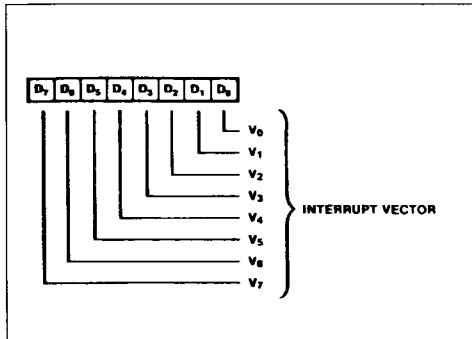
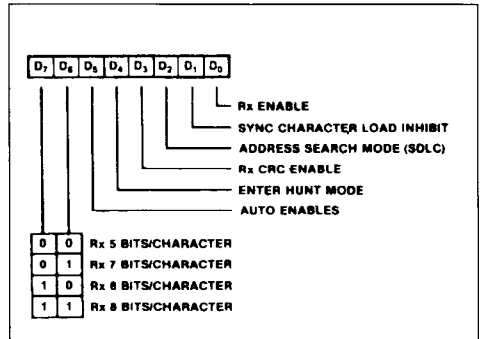

Figure 46 : Write Register 3.



REGISTERS DESCRIPTION (cont'd)

Write Register 2 (interrupt vector). WR2 is the interrupt vector register. Only one vector register exists in the SCC, but it can be accessed through either channel. The interrupt vector can be modified by status information. This is controlled by the Vector Includes Status (VIS) and the Status High/Status Low bits in WR9. The bit positions for WR2 are shown in Figure 45.

Write Register 3 (receive parameters and control). This register contains the control bits and parameters for the receiver logic as illustrated in Figure 46.

Bits 7 and 6 : Receiver Bits/Character

The state of these two bits determines the number of bits to be assembled as a character in the received serial data stream. The number of bits per character can be changed while a character is being assembled but only before the number of bits currently programmed is reached. Unused bits in the Received Data Register (RR8) are set to "1" in asynchronous modes and SDLC modes, the SCC merely transfers an 8-bit section of the serial data stream to the receive FIFO at the appropriate time. Table 9 lists the number of bits per character in the assembled character format.

Table 9 : Receive Bits/Character

B ₇	B ₆	
0	0	5 Bits / Character
0	1	7 Bits / Character
1	0	6 Bits / Character
1	1	8 Bits / Character

Bit 5 : Auto Enables

This bit programs the function for both the \overline{DCD} and CTS pins. CTS becomes the transmitter enable and \overline{DCD} becomes the receiver enable when this bit is set to "1". However, the Receiver Enable and Transmit Enable bits must be set before the \overline{DCD} and CTS pins can be used in this manner. When the Auto Enables bit is set to "0", the \overline{DCD} and CTS pins are merely inputs to the corresponding status bits in Read Register 0. The state of \overline{DCD} is ignored in the Local Loopback mode. The state of CTS is ignored in both Auto Echo and Local Loopback modes.

Bit 4 : Enter Hunt Mode

This command forces the comparison of sync characters or flags to assembled receive characters for the purpose of synchronization. After reset, the SCC automatically enters the Hunt mode (except asynchronous). Whenever a flag or sync character is matched, the Sync/Hunt bit in Read Register 0 is re-

set and, if External/Status Interrupt Enable is set, an interrupt sequence is initiated. The SCC automatically enters the Hunt mode when an abort condition is received or when the receiver is disabled.

Bit 3 : Receiver CRC Enable

This bit is used to initiate CRC calculation at the beginning of the last byte transferred from the Receiver Shift register to the receive FIFO. This operation occurs independently of the number of bytes in the receive FIFO. When a particular byte is to be excluded from CRC calculation, this bit should be reset before the next byte is transferred to the receive FIFO. If this feature is used, care must be taken to ensure that eight bits per character is selected in the receiver because of an inherent delay from the Receive Shift register to the CRC checker.

This bit is internally set to "1" in SDLC mode and the SCC calculates CRC on all bits except inserted zeros between the opening and closing character flags. This bit is ignored in asynchronous mode.

Bits 2 : Address Search Mode (SDLC)

Setting this bit in SDLC mode causes messages with addresses not matching the address programmed in WR6 to be rejected. No receiver interrupts can occur in this mode unless there is an address match. The address that the SCC attempts to match can be unique (1 in 256) or multiple (16 in 256), depending on the state of Sync Character Load Inhibit bit. The Address Search mode bit is ignored in all modes except SDLC.

Bit 1 : SYNC Character Load Inhibit

If this bit is set to "1" in any synchronous mode except SDLC, the SCC compares the byte in WR6 with the byte about to be stored in the FIFO, and it inhibits this load if the bytes are equal. The SCC does not calculate the CRC on bytes stripped from the Data stream in the manner. If the 6-bit sync option is selected while in Monosync mode, the compare is still across eight bits, so WR6 must be programmed for proper operation.

If the 6-bit sync option is selected with this bit set to "1", all sync characters except the one immediately preceding the data are stripped from the message. If the 6-bit sync option is selected while in the Bisync mode, this bit is ignored.

The address recognition logic of the receiver is modified in SDLC mode if this bit is set to "1", i.e., only the four most significant bits of WR6 must match the receiver address. This procedure allows the

REGISTERS DESCRIPTION (cont'd)

SCC to receive frames from up to 16 separate sources without programming WR6 for each source (if each station address has the four most significant bits in common). The address field in the frame is still eight bits long.

This bit is ignored in SDLC mode if Address Search mode has not been selected.

Bit 0 : Receiver Enable

When this bit is set to "1", receiver operation begins. This bit should be set only after all other receiver parameters are established and the receiver is completely initialized. This bit is reset by a channel or hardware reset command, and it disables the receiver.

Write Register 4 (transmit/receiver miscellaneous parameters and modes). WR4 contains the control bits for both the receiver and the transmitter. These bits should be set in the transmit and receiver initialization routine before issuing the contents of WR1, WR3, WR6, and WR7. Bit positions for WR4 are shown in Figure 47.

Bits 7 and 6 : Clock Rate 1 And 0

These bits specify the multiplier between the clock and data rates. In synchronous modes, the 1S mode is forced internally and these bits are ignored unless External Sync mode has been selected.

1X Mode (00). The clock rate and data rate are the same. In External Sync mode, this bit combination specifies that only the SYNC pin can be used to achieve character synchronization.

16X Mode (01). The clock rate is 16 times the data rate. In External Sync mode, this bit combination specifies that only the SYNC pin can be used to achieve character synchronization.

32X Mode (10). The clock rate is 32 times the data rate. In External Sync mode, this bit combination specifies that either the SYNC pin or a match with the character stored in WR7 will signal character synchronization. The sync character can be either six or eight bits long as specified by the 6-bit/8-bit Sync bit in WR10.

64X Mode (11). The clock rate is 64 times the data rate. With this bit combination in External Sync mode, both the receiver and transmitter are placed in SDLC mode. The only variation from normal SDLC operation is that the SYNC pin can be used to start or stop the reception of a frame by forcing the receiver to act as though a flag had been received.

Bits 5 and 4 : SYNC Modes 1 And 0

These two bits select the various options for character synchronization. They are ignored unless synchronous modes are selected in the stop bits field of this register.

Monosync (00). In this mode, the receiver achieves character synchronization by matching the character stored in WR7 with an identical character in the received data stream. The transmitter uses the character stored in WR6 as a time fill. The sync character can be either six or eight bits, depending on the state of the 6-bit/8-bit Sync bit in WR10. If the Sync Character Load Inhibit bit is set, the receiver strips the contents of WR6 from the data stream if received within character boundaries.

Bisync (01). The concatenation of WR7 with WR6 is used for receiver synchronization and as a time fill by the transmitter. The sync character can be 12 or 16 bits in the receiver, depending on the state of the 6-bit/8-bit Sync bit in WR10. The transmitted character is always 16 bits.

SDLC Mode (10). In this mode, SDLC is selected

Figure 47 : Write Register 4.

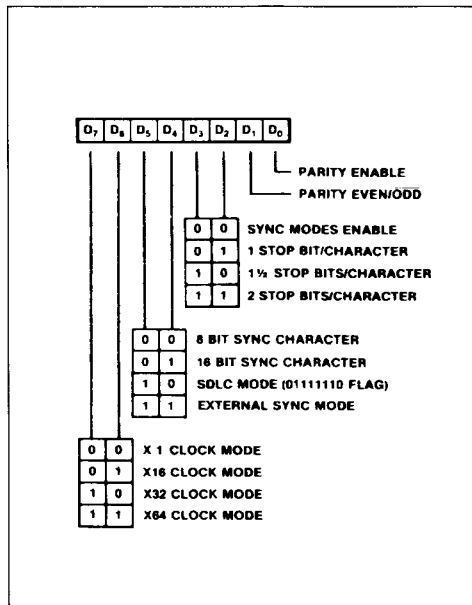

REGISTERS DESCRIPTION (cont'd)

and requires a Flag (01111110) to be written to WR7. The receiver address field should be written to WR6. The SDLC CRC polynomial must also be selected (WR5) in SDLC mode.

External Sync Mode (11). In this mode, the SCC expects external logic to signal character synchronization via the SYNC pin. If the crystal oscillator option is selected (in WR11), the internal SYNC signal is forced to "0". In this mode, bits B7-B6 of this register select special version of External Sync mode. In this mode, the transmitter is in Monosync mode using the contents of WR6 as the time fill with the sync character length specified by the 6-bit/8-bit Sync bit in WR10.

Bits 3 and 2 : Stop Bits 1 and 0

These bits determine the number of stop bits added to each asynchronous character that is transmitted. The receiver always checks for one stop bit in Asynchronous mode. A Special mode specifies that a Synchronous mode is to be selected. B2 is always set to "1" by a channel or hardware reset to ensure that the SYNC pin is in a known state after a reset.

Synchronous Modes Enable (00). This bit combination selects one of the synchronous modes specified by bits B4, B5, B6, and B7 of this register and forces the 1X Clock mode internally.

1 Stop Bit/Character (01). This bit selects Asynchronous mode with one stop bit per character.

1 1/2 Stop Bits/Character (10). These bits select Asynchronous mode with 1-1/2 stop bits per character. This mode can not be used with the 1X clock mode.

Figure 48 : Write Register 5.

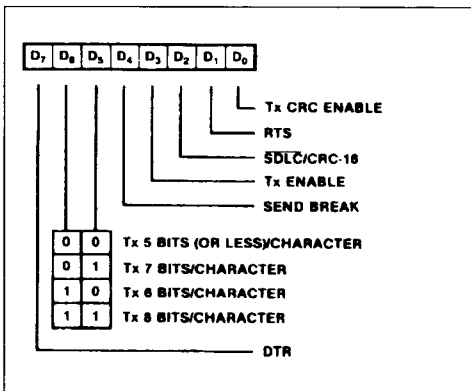

2 Stop Bits/Character (11). These bits select Asynchronous mode with two stop bits per transmitted character and check for one received stop bit.

Bit 1 : Parity Even/Odd

This bit determines whether parity is checked as even or odd. A "1" programmed here selects even parity, and a "0" selects odd parity. This bit is ignored if the Parity Enable bit is not set.

Bit 0 : Parity Enable

When this bit is set, an additional bit position beyond those specified in the bits/character control is added to the transmitted data and is expected in the receive data. The Received Parity bit is transferred to the CPU as part of the data unless eight bits per character is selected in the receiver.

Write Register 5 (transmit parameter and controls). WR5 contains control bits that affect the operation of the transmitter. B2 affects both the transmitter and the receiver. Bit positions for WR5 are shown in Figure 48.

Bit 7 : Data Terminal Ready

This is the control bit for the DTR/REQ pin while the pin is in the DTR mode (selected in WR14). When set, DTR is Low ; when reset, DTR is High. This bit is ignored when DTR/REQ is programmed to act as a REQUEST pin. This bit is reset by a channel or hardware reset.

Bits 6 and 5 : TXBits/Character 1 and 0

These bits control the number of bits in each byte transferred to the transmit buffer. Bits sent must be right justified with least significant bits first.

The Five Or Less mode allows transmission of one to five bits per character ; however, the CPU should form at the data character as shown below in Table 10. In the Six or Seven Bits/Character modes, unused data bits are ignored.

Table 10 : Tx Bits/Character 1 and 0.

Tx BITS / CHAR 1		Tx BITS / CHAR 0		
0	0	0	0	5 or less bits / character
0	1	0	1	7 bits / character
1	0	0	0	6 bits / character
1	1	0	1	8 bits / character

D7	D6	D5	D4	D3	D2	D1	D0	
1	1	1	1	0	0	0	0	Sends one data bit
1	1	1	0	0	0	0	0	Sends two data bits
1	1	0	0	0	0	0	0	Sends three data bits
1	0	0	0	0	0	0	0	Sends four data bits
0	0	0	0	0	0	0	0	Sends five data bits

REGISTERS DESCRIPTION (cont'd)

Bit 4 : Send Break

When set, this bit forces the TxD output to send continuous "0s" beginning with the following transmit clock, regardless of any data being transmitted at the time. This bit functions whether or not the transmitter is enabled. When reset, TxD continues to send the contents of the Transmit Shift register, which might be syncs, data or all "1s". If this bit is set while in the X21 mode (Monosync and Loop mode selected) and character synchronization is achieved in the receiver, this bit is automatically reset and the transmitter begins sending syncs or data. This bit can also be reset by a channel or hardware reset.

Bit 3 : Transmit Enable

Data is not transmitted until this bit is set, and the TxD output sends continuous "1s" unless Auto Echo mode or SDLC Loop mode is selected. If this bit is reset after transmission started, the transmission of data or sync characters is completed. If the transmitter is disabled during the transmission of a CRC character, sync or flag characters are sent instead of CRC. This bit is reset by a channel or hardware reset.

Bit 2 : SDLC/CRC-16

This bit selects the CRC polynomial used by both the transmitter and receiver. When set, the CRC-16 polynomial is used ; when reset, the SDLC polynomial is used. The SDLC/CRC polynomial must be selected when SDLC mode is selected. The CRC generator and checker can be preset to all "0s" or all "1s", depending on the state of the Preset 1/ Preset 0 bit in WR10.

Bit 1 : Request To Send

This is the control bit for the RTS pin. When the RTS bit is set, the RST pin goes Low ; when reset, RTS

goes High. In the Asynchronous mode with the Auto Enables bit set, RST goes High only after all bits of the character have been sent and the transmit buffer is empty. In synchronous modes of the Asynchronous mode with auto enables off, the pin directly follows the state of this bit. This bit is reset by a channel or hardware reset.

Bit 0 : Transmit CRC Enable

This bit determines whether or not CRC is calculated on a transmit character. If this bit is set at the time the character is loaded from the transmit buffer to the Transmit Shift register, CRC is calculated on that character. CRC is not automatically sent unless this bit is set when the transmit underrun exists.

Write Register 6 (sync characters or SDLC address field). WR6 is programmed to contain the transmit sync character in the Monosync mode, the first byte of a 16-bit sync character in the External Sync mode. In the SDLC modes, it is programmed to contain the secondary address field used to compare against the address field of the SDLC Frame. In SDLC mode, the SCC does not automatically transmit the station address at the beginning of the response frame. Bit positions for WR6 are shown in Figure 49.

Write Register 7 (sync character or SDLC flag). WR7 is programmed to contain the receive sync character in the Monosync mode, a second byte (the last eight bits) of a 16-bit sync character in the Bi-sync mode, or a Flag character (01111110) in the SDLC modes. WR7 may hold the receive sync character or a flag if one of the special versions of the External Sync mode is selected. WR7 is not used in Asynchronous mode. Bit positions for WR7 are shown in Figure 50.

Figure 49 : Write Register 6.

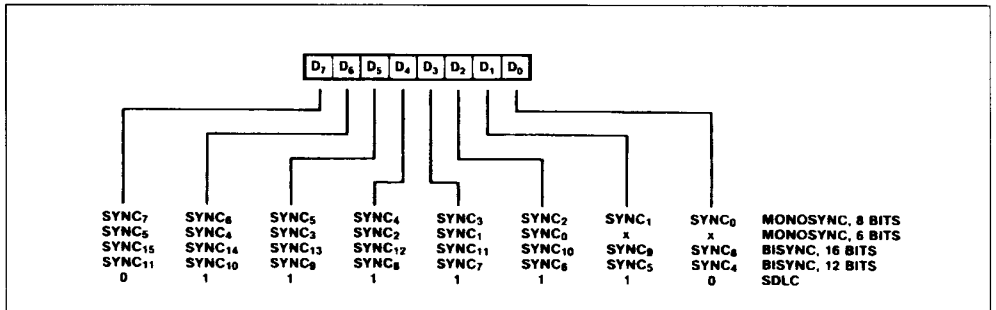

REGISTERS DESCRIPTION (cont'd)

Figure 50 : Write Register 7.

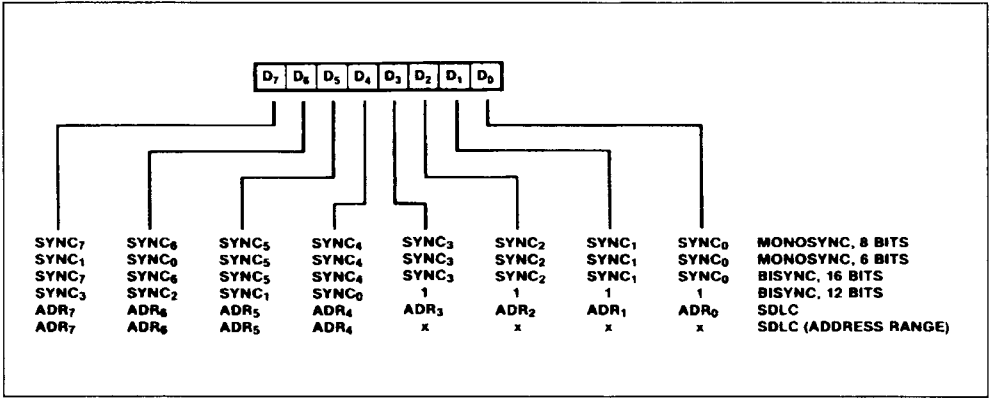
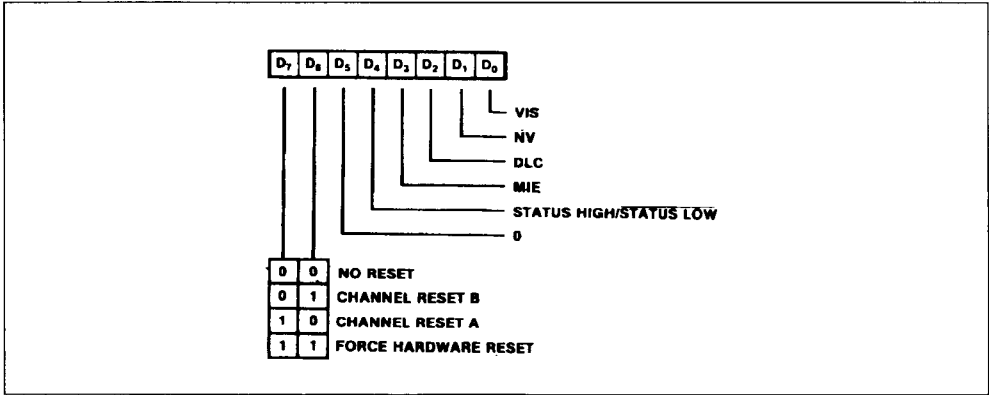

Figure 51 : Write Register 9 .



Write Register 8 (transmit buffer). WR8 is the transmit buffer register.

Write Register 9 (master interrupt control). WR9 is the Master Interrupt Control register and contains the Reset command bits. Only one WR9 exists in the SCC and can be accessed from either channel. The interrupt control bits can be programmed at the same time as the Reset command because these bits are only reset by a hardware reset. Bit positions for WR9 are shown in Figure 51.

Bits 7 and 6 : Reset Command Bits

Together, these bits select one of the reset com-

mands for the SCC. Setting either of these bits to "1" disables both the receiver and the transmitter in the corresponding channel, forces TxD for that channel marking, forces the modem control signals High in that channel, resets all IPs and IUSs and disables all interrupts in that channel. Four extra PCLK cycles must be allowed beyond the usual cycle time after any of the active reset commands is issued before any additional commands or controls are written to the channel affected. Four extra PCLK cycles must be allowed beyond the usual cycle time before any additional command or controls are written to the SCC.

REGISTERS DESCRIPTION (cont'd)

No Reset (00). This command has no effect. It is used when a write to WR9 is necessary for some reason other than an SCC Reset command.

Channel Reset B (01). Issuing this command causes a channel reset to be performed on Channel B.

Channel Reset A (10). Issuing this command causes a channel reset to be performed on Channel A.

Force Hardware Reset (11). The effects of this command are identical to those of a hardware reset, except that the Shift Right/Shift Left bit is not changed and the MIE, Status High/Status Low and DLC bits take the programmed values that accompany this command.

Bit 5 : Not Used

Must be "0".

Bit 4 : Status High/Status Low

This bit controls which vector bits the SCC will modify to indicate status. When set to "1", the SCC modifies bits V6, V5, and V4 according to Table 11. When set to "0", the SCC modifies bits V1, V2, and V3 according to Table 11. This bit controls status in both the vector returned during an interrupt acknowledge cycle and the status in RR2B. This bit is reset a hardware reset.

Table 11 : Interrupt Vector Modification.

V3	V2	V1	Status High / Status Low = 0
V4	V5	V6	Status High / Status Low = 1
0	0	0	Ch B Transmit Buffer Empty
0	0	1	Ch B External / Status Change
0	1	0	Ch B Receive Character Avail.
0	1	1	Ch B Special Receive Condition
1	0	0	Ch A Transmit Buffer Empty
1	0	1	Ch A External / Status Change
1	1	0	Ch A Receive Character Avail.
1	1	1	Ch A Special Receive Condition

Bit 3 : Master Interrupt Enable

This bit is set to 1 to globally enable interrupts, and cleared to zero to disable interrupts. Clearing this bit to zero forces the IEO pin to follow the state of the IEI pin unless there is an IUS bit set in the SCC.

No IUS bit can be set after the MIE bit is cleared to zero. This bit is reset by a hardware reset.

Bit 2 : Disable Lower Chain

The Disable Lower Chain bit can be used by the CPU to control the interrupt daisy chain. Setting this bit to "1" forces the IEO pin Low, preventing lower-

priority devices on the daisy chain from requesting interrupts. This bit is reset by a hardware reset.

Bit 1 : No Vector

The No Vector bit controls whether or not the SCC will respond to an interrupt acknowledge cycle by placing a vector on the data bus if the SCC is the highest-priority device requesting an interrupt. If this bit is set, no vector is returned ; i.e., AD0-AD7 remain three-stated during an interrupt acknowledge cycle, even if the SCC is the highest-priority device requesting an interrupt.

Bit 0 : Vector Includes Status

The Vector Includes Status Bit controls whether or not then SCC will include status information in the vector it places on the bus in response to an interrupt acknowledge cycle. If this bit is set, the vector returned is variable, with the variable field depending on the highest-priority IP that is set. Table 11 shows the encoding of the status information. This bit is ignored if the No Vector (NV) bit is set.

Figure 52 : Write Register 10.

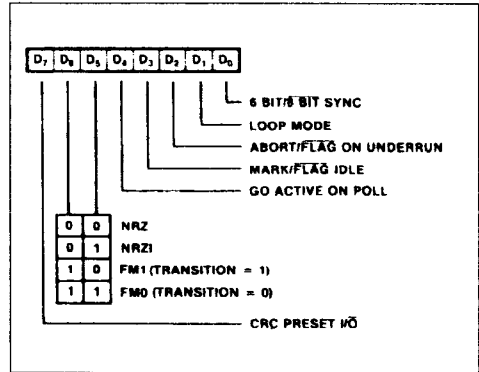

Write Register 10 (miscellaneous transmitter/receiver control bits). WR10 contains miscellaneous control bits for both the receiver and the transmitter. Bit positions for WR10 are shown in Figure 52.

Bit 7 : CRC Preset $\overline{1/0}$

This bit specifies the initialized condition of the receive CRC checker and the transmit CRC generator. If this bit is set to "1", the CRC generator and checker are preset to "1". If this bit is set to "0", the CRC generator and checker are preset to "0". Either option can be selected with either CRC polynomial.

REGISTERS DESCRIPTION (cont'd)

In SDLC mode, the transmitted CRC is inverted before transmission and the received CRC is checked against the bit pattern "0001110100001111". This bit is reset by a channel or hardware reset. This bit is ignored in Asynchronous mode.

Bit 6 and 5 : Data Encoding 1 and 2

These bits control the coding method used for both the transmitter and the receiver, as illustrated in Table 12. All of the clocking options are available for all coding methods. The DPLL in the SCC is useful for recovering clocking information in NRZI and FM modes. A hardware reset forces NRZ mode. Timing for the various modes is shown in Figure 53.

Table 12 : Data Encoding

Data	Data Encoding	Encoding
0	0	NRZ
0	1	NRZI
1	0	FM1 (transition = 1)
1	1	FM0 (transition = 1)

Bit 4 : Go Active On Poll

When Loop mode is first selected during SDLC operation, the SCC connects RxD to TxD with only gate delays in the path. The SCC does not go on-loop and insert the 1-bit delay between RxD and TxD until this bit has been set and an EOP received. When the SCC is on-loop, the transmitter cannot go active unless this bit is set at the time an EOP is received. The SCC examines this bit whenever the transmitter is active in SDLC Loop mode and is sending a flag. If this bit is set at the time the flag is leaving the Transmit Shift register, another flag or data byte (if the transmit buffer is full) is transmitted. If the Go Active on Poll bit is not set at this time, the transmitter finishes sending the flag and reverts to the 1-Bit Delay mode. Thus, to transmit only one response frame, this bit should be reset after the first data byte is sent to the SCC but before CRC has been transmitted. If the bit is not reset before CRC is transmitted, extra flags are sent, slowing down response time on the loop. If this bit is reset before the first data is written, the SCC completes the transmission of the present flag and reverts to the 1-Bit Delay mode. After gaining control of the loop, the SCC is not able to transmit again until a flag and another EOP have been received. Though not strictly necessary, it is good practice to set this bit only upon receipt of a poll frame to ensure that the SCC does not go on loop without the CPU noticing it.

In synchronous modes other than SDLC with the Loop Mode bit set, this bit must be set before the

transmitter can go active in response to a received sync character.

This bit is always ignored in Asynchronous mode and Synchronous modes unless the Loop Mode bit is set. This bit is reset by a channel or hardware reset.

Bit 3 : Mark/Flag Idle

This bit affects only SDLC operation and is used to control the idle line condition. If this bit is set to "0", the transmitter sends flags an idle line. If this bit is set to "1", the transmitter sends continuous "1s" after the closing flag of a frame. The idle line condition is selected byte by byte ; i.e., either a flag or eight "1s" are transmitted. The primary station in an SDLC loop should be programmed for Mark Idle to create the EOP sequence . Mark Idle must be deselected at the beginning of a frame before the first data is written to the SCC, so that an opening flag can be transmitted. This bit is ignored in Loop mode, but the programmed value takes effect upon exiting the Loop mode. This bit is reset by a channel or hardware reset.

Bit 2 : Abort/Flag On Underrun

This bit affects only SDLC operation and is used to control how the SCC responds to a transmit underrun condition. If this bit is set to "1" and a transmit underrun occurs, the SCC sends an abort and a flag instead of CRC. If this bit is reset, the SCC sends CRC on a transmit underrun. At the beginning of this 16-bit transmission, the Transmit Underrun/EOM bit is set, causing an External/Status interrupt. The CPU uses this status, along with the byte count from memory or the DMA, to determine whether the frame must be retransmitted. A transmit buffer Empty interrupt occurs at the end of this 16-bit transmission to start the next frame. If both this bit and the Mark/Flag Idle bit are set to "1", all "1s" are transmitted after the transmit underrun. This bit should be set after the first byte of data is sent to the SCC and reset immediately after the last byte of data so that the frame will be terminated properly with CRC and a flag. This bit is ignored in Loop mode, but the programmed value is active upon exiting Loop mode. This bit is reset by a channel or hardware reset.

Bit 1 : Loop Mode

In SDLC mode, the initial set condition of this bit forces the SCC to connect TxD to TxD and to begin searching the incoming data stream so that it can go on loop. All bits pertinent to SDLC mode operation in other registers must be set before this mode

REGISTERS DESCRIPTION (cont'd)

Figure 53 : NRZ(NRZI)FM1(FM0) Timing.

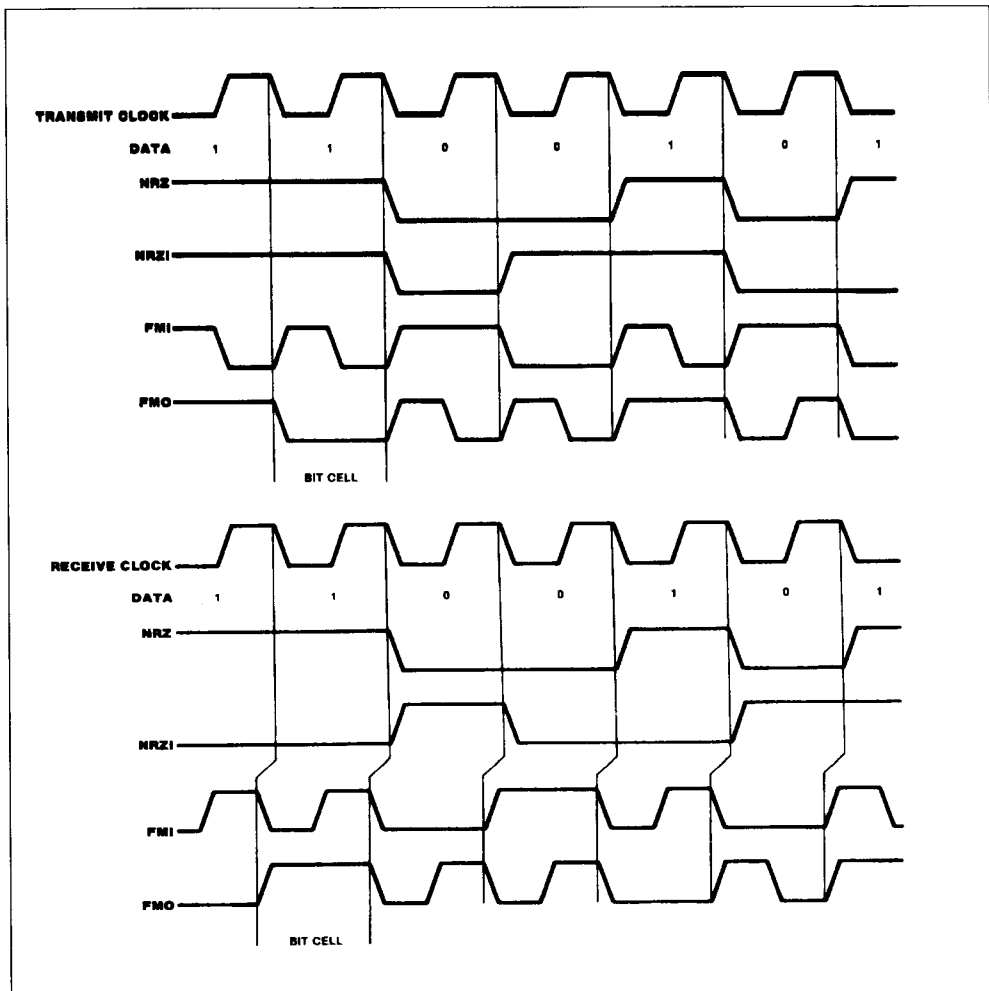

REGISTERS DESCRIPTION (cont'd)

is selected. The transmitter and receiver should not be enabled until after this mode has been selected. As soon as the Go Active Onn Poll bit is set and an EOP is received the SCC goes on loop. If this bit is reset after the SCC is on loop, the SCC waits for the next EOP to go off loop.

In synchronous modes, the SCC uses this bit, along with the Go Active On Poll bit, to synchronize the transmitter to the receiver. The receiver should not be enabled until after this mode is selected. The TxD pin is held marking when this mode is selected unless a break condition is programmed. The receiver waits for a sync character to be received and then enables the transmitter on a character boundary. The break condition, if programmed, is removed. This mode works properly with sync characters of 6, 8, or 16 bits. This bit is ignored in Asynchronous mode and is reset by a channel or hardware reset.

Bit 0 : 6 Bit/8 Bit SYNC

This bit is used to select a special case of synchronous modes. If this bit is set to "1" in Monosync mode, the receiver and transmitter sync characters are six bits long instead of the usual eight. If this bit is set to "1" in Bisync mode, the received sync will be 12 bits and the transmitter sync character will remain 16 bits long. This bit is ignored in SDLC and Asynchronous modes but still has effect in the special external sync modes. This bit is reset by a channel or hardware reset.

Write Register 11 (clock mode control). WR11 is the Clock Mode Control register. The bits in this register control the sources of the both the receive and transmit clocks, the type of signal on the SYNC and RTxC pins, and the direction of the TRxC pin. Bit positions for WR11 are shown in Figure 54.

Bit 7 : RTxC-XTAL/NO XTAL

This bit controls the type of input signal the SCC expects to see on the RTxC pin. If this bit is set to "0", the SCC expects a TTL-compatible signal as an input to this pin. If this bit is set to "1", the SCC connects a high-gain amplifier between the RTxC and SYNC pins in expectation of a quartz crystal being placed across the pins.

The output of this oscillator is available for use as a clocking source. In this mode of operation, the SYNC pin is unavailable for other use. The SYNC-signal is forced to "0" internally. A hardware reset forces NO XTAL. (At least 20 ms should be allowed after this bit is set to allow the oscillator to stabilize.)

Bits 6 and 5 : Receiver Clock 1 And 0

These bits determine the source of the receive clock as shown in Table 13. They do not interfere with any of the modes of operation in the SCC but simply control a multiplexer just before the internal receive clock input. A hardware reset forces the receive clock to come from the TRxC pin.

Table 13 : Receive Clock Source.

Receive Clock 1	Receive Clock 0	
0	0	Receive Clock = RTxC Pin
0	1	Receive Clock = TRxC Pin
1	0	Receive Clock = BR Output
1	1	Receive Clock = DPLL Output

Bits 4 and 3 : Transmit Clock 1 and 0

These bits determine the source of the transmit clock as shown in Table 14. They do not interfere with any of the modes of operation of the SCC but simply control a multiplexer just before the internal transmit clock input. The DPLL output that may be used to feed the transmitter in FM modes lags by 90 the output of the DPLL used by the receiver. This makes the received and transmitted bit cells occur simultaneously, neglecting delays. A hardware reset selects the TRxC pin as the source of the transmit clocks.

Table 14 : Transmit Clock Source.

Transmit Clock 1	Transmit Clock 0	
0	0	Transmit Clock = RTxC Pin
0	1	Transmit Clock = TRxC Pin
1	0	Transmit Clock = BR Output
1	1	Transmit Clock = DPLL Output

Bit 2 : TRxC O/I

This bit determines the direction of the TRxC pin. If this bit is set to "1", the TRxC pin is an output and carries the signal selected by D1 and D0 of this register. However, if either the receive or the transmit clock is programmed to come from the TRxC pin, TRxC will be an input, regardless of the state of this bit. The TRxC pin is also an input if this bit is set to "0". A hardware reset forces this bit to "0".

Bits 1 and 0 : TRxC Output Source 1 And 0

These bits determine the signal to be echoed out of the SCC via the TRxC pin. No signal is produced if TRxC has been programmed as the source of either

REGISTERS DESCRIPTION (cont'd)

Figure 54 : Write Register 11.

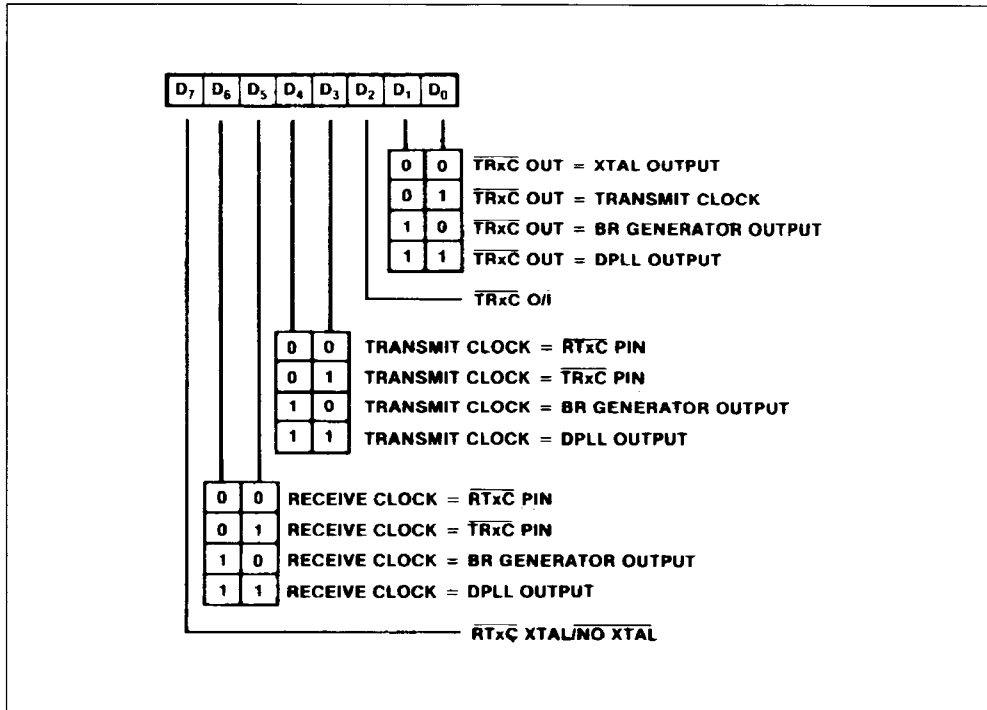

the receive or the transmit clock. If TRxC O/I (bit 2) is set to "0", these bits are ignored.

If the XTAL oscillator output is programmed to be echoed, and the Xtal oscillator has not been enabled, the TRxC pin goes High. The DPLL signal that is echoed is the DPLL signal used by the receiver. Hardware reset selects the XTAL oscillator as the output source.

Table 15 : Transmit External Control Selection.

Output Signal	Output Signal	
0	0	TRxC = XTAL Oscillator Output
0	1	TRxC = Transmit Clock
1	0	TRxC = B R Output
1	1	TRxC = DPLL Output (Receive)

Write Register 12 (lower byte of baud rate generator time constant). WR12 contains the lower byte of the time constant for the baud rate generator. The time constant can be changed at any time, but the new value does not take effect until the next time the time constant is loaded into the down counter. No attempt is made to synchronize the loading of the time constant into WR12 and WR13 with the clock driving the down counter. For this reason, it is advisable to disable the baud rate generator while the new time constant is loaded into WR12 and WR13. Ordinarily, this is done anyway to prevent a load of the down counter between the writing of the upper and lower bytes of the time constant.

The formula for determining the appropriate time constant for a given baud is shown below with the desired rate in bits per second and the BR clock pe-

REGISTERS DESCRIPTION (cont'd)

riod in seconds. This formula is derived because the counter decrements from N down to "0"- plus-one-cycle for reloading the time constant and is then fed to a toggle flip-flop to make the output a square wave. Bit positions for WR12 are shown in Figure 55.

Time constant = $[1/2 \text{ desired rate} \cdot \text{BR clock period}] - 2$

Figure 55 : Write Register 12.

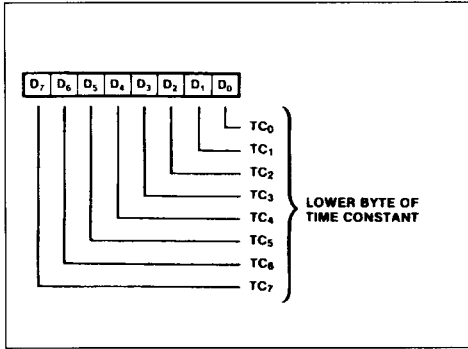

Write Register 13 (upper byte of baud rate generator time constant). WR13 contains the upper byte of the time constant for the baud rate generator. Bit positions for WR13 are shown in Figure 56.

Write Register 14 (miscellaneous control bits). WR14 contains some miscellaneous control bits. Bit positions for WR14 are shown in Figure 57.

Bits 7 and 5 : Digital Phase-Locked Loop Command Bits

These three bits encode the eight commands for the Digital Phase-Locked Loop. A channel or hardware reset disables the DPLL, resets the mission clock latches, sets the source to the RTxC pin and selects NRZI mode. The Enter Search Mode command enables the DPLL after a reset.

Null Command (000). This command has no effect on the DPLL.

Enter Search Mode (001). Issuing this command causes the DPLL to enter the Search mode, where the DPLL searches for a locking edge in the incoming data stream. The action taken by the DPLL upon receipt of this command depends on the operating mode of the DPLL.

Figure 56 : Write Register 13.

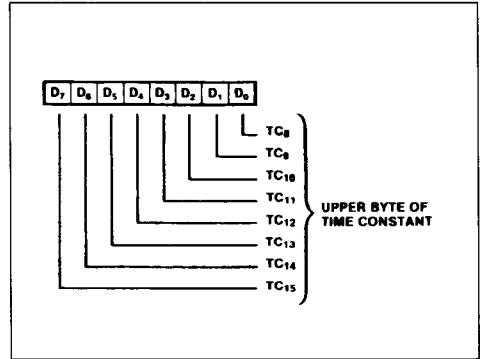
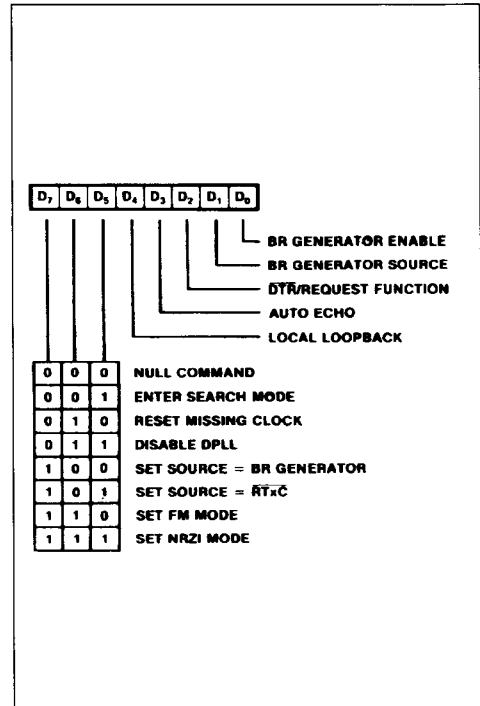

Figure 57 : Write Register 14.



REGISTERS DESCRIPTION (cont'd)

In NRZI mode, the output of the DPLL is High while the DPLL is waiting for an edge in the incoming data stream. After the Search mode is entered, the first edge the DPLL sees is assumed to be a valid data edge, and the DPLL begins the clock recovery operation from that point. The DPLL clock rate must be 32 times the data rate in NRZI mode. Upon leaving the Search mode, the first sampling edge of the DPLL occurs 16 of these 32X clocks after the first data edge and the second sampling edge occurs 48 of these 32X clocks after the first data edge. Beyond this point, the DPLL begins normal operation, adjusting the output to remain in sync with the incoming data.

In FM mode, the output of the DPLL is Low while the DPLL is waiting for an edge in the incoming data stream. The first edge the DPLL detects is assumed to be a valid clock edge. For this to be the case, the line must contain only clock edges ; i.e., with FM1 encoding, the line must be continuous "0s". With FM0 encoding the line must be continuous "1s", whereas Manchester encoding requires alternating "1s" and "0s" on the line. The DPLL clock rate must be 16 times the data rate in FM mode. The DPLL output causes the receiver to sample the data stream in the nominal center of the two halves of the bit cell to decide whether the data was a "1" or a "0". After this command is issued, as in NRZI mode, the DPLL starts sampling immediately after the first edge is detected. (In FM mode, the DPLL examines the clock edge of every other bit cell to decide what correction must be made to remain in sync). If the DPLL does not see an edge during the expected window, the one clock mission bit in RR10 is set. If the DPLL does not see an edge after two successive attempts, the two clocks missing bit in RR10 is set and the DPLL automatically enters the Search mode. This command resets both clock missing latches.

Reset Clock Missing (010). Issuing this command disables the DPLL, resets the clock missing latches in RR10, and forces a continuous Search mode state.

Disable DPLL (001). Issuing this command disables the DPLL, resets the clock missing latches in RR10, and forces a continuous Search mode state.

Set Source = BR Gen (100). Issuing this command forces the clock for the DPLL to come from the output of the baud rate generator.

Set Source = RTxC (101). Issuing the command forces the clock for the DPLL to come from the RTxC pin or the crystal oscillator, depending on the state

of the XTAL/no XTAL bit in WR11. This mode is selected by a channel or hardware reset.

Set FM Mode (110). This command forces the DPLL to operate in the FM mode and is used to recover the clock from FM or Manchester-encoded data. (Manchester is decoded by placing the receiver in NRZ mode while the DPLL is in FM mode.)

Set NRZI Mode (111). Issuing this command forces the DPLL to operate in the NRZI mode. This mode is also selected by a hardware or channel reset.

Bit 4 : Local Loopback

Setting this bit to "1" selects the local Loopback mode of operation. In this mode, the internal transmitted data is routed back to the receiver, as well as to the TxD pin. The $\overline{\text{CTS}}$ and $\overline{\text{DCD}}$ inputs are ignored as enables in Local Loopback mode, even if auto enables is selected. (If so programmed, transitions on these inputs still cause interrupts.) This mode works with any Transmit/Receive mode except Loop mode. For meaningful results, the frequency of the transmit and receive clocks must be the same. This bit is reset by a channel or hardware reset.

Bit 3 : Auto Enable

Setting this bit to "1" selects the Auto Enable mode of operation. In this mode, the TxD pin is connected to RxD, as in Local Loopback mode, but the receiver still listens to the RxD input. Transmitted data is never seen inside or outside the SCC in this mode, and $\overline{\text{CTS}}$ is ignored as a transmit enable. This bit is reset by a channel or hardware reset.

Bit 2 : DTR/Request Function

This bit selects the function of the $\overline{\text{DTR}}/\overline{\text{REQ}}$ pin follows the state of the DTR bit in WR5. If this bit is set to "1", the $\overline{\text{DTR}}/\overline{\text{REQ}}$ pin follows the state of the DTR bit in WR5. If this bit is set to "1", the $\overline{\text{DTR}}/\overline{\text{REQ}}$ pin goes Low whenever the transmit buffer becomes empty and in any of the synchronous mode when CRC has been sent at the end of a message. The request function on the $\overline{\text{DTR}}/\overline{\text{REQ}}$ pin differs somewhat from the transmit request function available on the $\overline{\text{W}}/\overline{\text{REQ}}$ pin in that $\overline{\text{REQUEST}}$ does not go inactive until the internal operation satisfying the request is complete, which occurs four to five PCLK cycles after the rising edge of $\overline{\text{DS}}$, $\overline{\text{READ}}$ or $\overline{\text{WRITE}}$. If the DMA used is edge-triggered, this difference is unimportant. This bit is reset by a channel or hardware reset.

Bit 1 : Baud Rate Generator Source

This bit selects the source of the clock for the baud rate generator. If this bit is set to "0", the baud rate

REGISTERS DESCRIPTION (cont'd)

generator clock comes from either the \overline{RTxC} pin or the XTAL oscillator (depending on the state of the XTAL/no XTAL bit). If this bit is set to "1", the clock for the baud rate generator is the SCC's PCLK input. Hardware reset sets this bit to "0", selecting the \overline{RTxC} pin as the clock source for the baud rate generator.

Bit 0 : Baud Rate Generator Enable

This bit controls the operation of the baud rate generator. The counter in the baud rate generator is enabled for counting when this bit is set to "1", and counting is inhibited when this bit is set to "0". When this bit is set to "1", change in the state of this bit is not reflected by the output of the baud rate generator for two counts of the counter. This allows the command to be synchronized. However, when set to "0", disabling is immediate. This bit is reset by a hardware reset.

Write Register 15 (external/status interrupt control). WR15 is the External/Status Source Control register. If the External/Status interrupts are enabled as a group via WR1, bits in this register control which External/Status conditions can cause an interrupt. Only the External/Status conditions that occur after the controlling bit are sent to "1" will cause an interrupt. This is true even if an External/Status condition is pending at the time the bit is set. Bit positions for WR15 are shown in Figure 58.

Bit 7 : Break/Abort IE

If this bit is set to "1", a change in the Break/Abort status of the receiver causes an External/Status interrupt. This bit is set by a channel or hardware reset.

Bit 6 : Tx Underrun/EOM

If this bit is set to "1", a change of state by the Tx Underrun/EOM latch in the transmitter causes an External/Status interrupt. This bit is set to "1" a channel or hardware reset.

Bit 5 : CTS IE

If this bit is set to "1", a change of state on the \overline{CTS} pin causes an External/Status interrupt. This bit is set by a channel or hardware reset.

Bit 4 : SYNC/Hunt IE

If this bit is set to "1", a change of state on the \overline{SYNC} pin causes an External/Status interrupt in Asynchronous mode, and a change of state in the Hunt

bit in the receiver causes an External/Status interrupt in synchronous modes. This bit is set by a channel or hardware reset.

Bit 3 : DCD IE

If this bit is set to "1", a change of state on the \overline{DCD} pin causes an External/Status interrupt. This bit is set by a channel or hardware reset.

Bit 2 : Not Used

Must be "0".

Bit 1 : Zero Count IE

If this bit is set to "1", an External/Status interrupt is generated whenever the counter in the baud rate generator reaches "0". This bit is set to "0" by a channel or hardware reset.

Bit 0 : Not Used

Must be "0".

READ REGISTERS

The Z8530 SCC contains seven read registers in each channel. In addition there are two registers which are shared by both channels. The status of these registers is continually changing and depends on the mode of communication, received and transmitted data, and the manner in which this data is transferred to and from the CPU. The following description details the bit assignments for each register.

Read Register 0 (transmit/ receiver buffer status and external status). Read Register 0 contains the status of the receive and transmit buffers. RR0 also contains the status bits for the six sources of External/Status interrupts. The bit configuration is illustrated in Figure 59.

Bit 7 : Break/Abort

In the Asynchronous mode, this bit is set when a Break sequence (null character plus framing error) is detected in the receive data stream. This bit is reset when the sequence is terminated, leaving a single null character in the receive FIFO. This character should be read and discarded. In SDLC mode, this bit is set by the detection of an Abort sequence (seven or more "1s"), then reset automatically at the termination of the Abort sequence. In either case, if the Break/Abort IE bit is set, an External/Status interrupt is initiated. Unlike the remainder of the External/Status bits, both transitions are guaranteed to

REGISTERS DESCRIPTION (cont'd)

cause an External/Status interrupt, even if another External/Status interrupt is pending at the time these transitions occur. This procedure is necessary because Abort or Break conditions may not persist.

Bit 6 : TX Underrun/EOM

This bit is set by a channel or hardware reset and when the transmitter is disabled or a Send Abort command is issued. This bit can only be reset by the reset Tx Underrun/EOM Latch command in WR0. When the Transmit Underrun occurs, this bit is set and causes an External/Status interrupt (if the Tx Underrun/EOM IE bit is set).

Only the 0-to-1 transition of this bit causes an interrupt. This bit is always "1" in Asynchronous mode, unless a reset Tx Underrun/EOM Latch command has been erroneously issued. In this case, the Send Abort command can be used to set the bit to one and at the same time cause an External/Status interrupt.

Bit 5 : Clear to Send

If the CTS IE bit in WR15 is set, this bit indicates the state of the CTS pin the last time any of the enabled External/Status bits changed. Any transition on the CTS pin while no interrupt is pending latches the state of the CTS pin and generates an External/Status interrupt. Any odd number of transitions on the CTS pin while another External/Status interrupt is pending also causes an External/Status interrupts condition. If the CTS IE bit is reset, it merely reports the current unlatched state of the CTS pin.

Bit 4 : SYNC/Hunt

The operation of this bit is similar to that of the CTS

bit, except that the condition monitored by the bit varies depending on the mode in which the SCC is operating.

When the XTAL oscillator option is selected in asynchronous modes, this bit is forced to "0" (no External/Status interrupt is generated). Selecting the XTAL oscillator in synchronous or SDLC modes had no effect on the operation of this bit.

The XTAL oscillator should not be selected in External Sync mode.

In Asynchronous mode, the operation of this bit is identical to that of the CTS status bit, except that this bit reports the state of the SYNC pin.

In External sync mode the SYNC pin is used by external logic to signal character synchronization. When the Enter Hunt Mode command is issued in External Sync mode, the SYNC pin must be held High by the external sync logic until character synchronization is achieved. A High on the SYNC pin holds the Sync/Hunt bit in the reset condition.

When external synchronization is achieved, SYNC must be driven Low on the second rising edge of the Receive Clock after the last rising edge of the Receive Clock on which the last bit of the receive character was received. Only SYNC is forced Low, it is good practice to keep it Low until the CPU informs the external sync logic that synchronization has been lost or that a new message is about to start. Both transitions on the SYNC pin cause External/Status interrupts if the Sync/Hunt IE bit is set to "1".

The Enter Hunt Mode command should be issued

Figure 58 : Write Register 15.

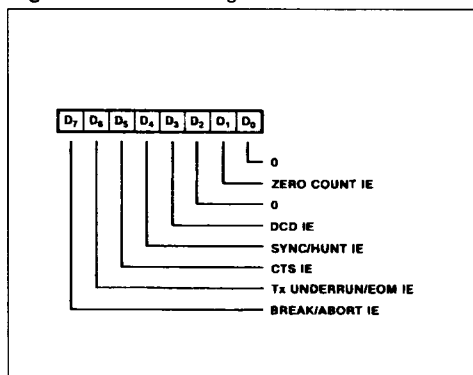
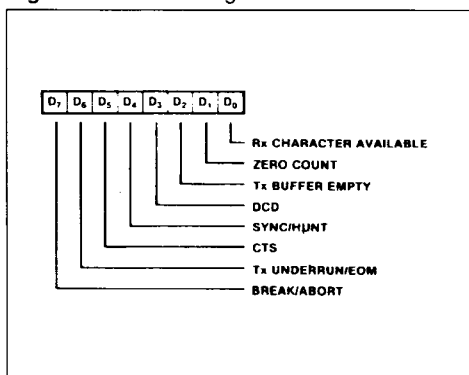

Figure 59 : Read Register 0.



REGISTERS DESCRIPTION (cont'd)

whenever character synchronization is lost. At the same time, the CPU should inform the external logic that character synchronization has been lost and that the SCC is waiting for SYNC to become active.

In the Monosync and Bisync Receive modes, the Sync/Hunt status bit is initially set to "1" by the Enter Hunt Mode command. The Sync/Hunt bit is reset when the SCC established character synchronization. Both transitions cause External/Status interrupts if the Sync/Hunt IE bit is set. When the CPU detects the end of message or the loss of character synchronization, the Enter Hunt Mode command should be issued to set the Sync/Hunt bit and cause an External/Status interrupt. In this mode, the SYNC pin is an output, which goes Low every time a sync pattern is detected in the data stream.

In the SDLC modes, the Sync/Hunt bit is initially set by the Enter Hunt Mode command or when the receiver is disabled. It is reset when the opening flag of the first frame is detected by the SCC. An External/Status interrupt is also generated if the Sync/Hunt IE bit is set. Unlike the Monosync and Bisync modes, once the Sync/Hunt bit is reset in SDLC mode, it does not need to be set when the end of the frame is detected. The SCC automatically maintains synchronization. The only way the Sync/Hunt bit can be set again is by the Enter Hunt Mode command or by disabling the receiver.

Bit 3 : Data Carrier Detect

If the DCD bit in WR15 is set, this bit indicates the state of the DCD pin the last time the Enabled External/Status bits changed. Any transition on the DCD pin while no interrupt is pending latches the state of the DCD pin, and generates an External/Status interrupt. Any odd number of transitions on the DCD pin while another External/Status interrupt is pending also causes an External/Status interrupt condition. If the DCD IE is reset, this bit merely reports the current, unlatched state of the DCD pin.

Bit 2 : TX Buffer Empty

This bit is set to "1" when the transmit buffer is empty. It is reset while CRC is sent in a synchronous or SDLC mode and while the transmit buffer is full. The bit is reset when a character is loaded into the transmit buffer. This bit is always in the set condition after a hardware or channel reset.

Bit 1 : Zero Count

If the Zero Count Interrupt Enable bit is set in WR15,

this bit is set to one while the counter in the baud rate generator is at the count of zero. If there is no other External / Status interrupt condition pending at the time this bit is set, an External/Status interrupt is generated. However, if there is another External/Status interrupt pending at this time, no interrupt is initiated until interrupt service is complete. If the Zero Count condition does not persist beyond the end of the interrupt service routine, no interrupt will be generated. This bit is not latched High, even though the other External/Status latches close as a result of the Low-to-High transition on ZC. The interrupt service routine should check the other External / Status conditions for changes. If none changed, ZC was the source. In polled applications, check the IP bit in RR3A for a status change and then proceed as in the interrupt service routine.

Bit 0 : RX Character Available

This bit is set to "1" when at least one character is available in the receive FIFO and is reset when the receive FIFO is completely empty. A channel or hardware reset empties the receive FIFO.

Read Register 1. RR1 contains the Special Receive Condition status bits and the residue codes for the I-field in SDLC mode. Figure 60 shows the bit positions for RR1.

Bit 7 : End of Frame (SDLC)

This bit is used only in SDLC mode and indicates that a valid closing flag has been received and that the CRC Error bit and residue codes are valid. This bit can be reset by issuing the Error Reset command. It is also updated by the first character of the following frame. This bit is reset in any mode other than SDLC.

Bit 6 : CRC/Framing Error

If a framing error occurs (in Asynchronous mode), this bit is set (and not latched) for the receive character in which the framing error occurred. Detection of a framing error adds an additional one-half bit to the character time so that the framing error is not interpreted as a new Start bit. In Synchronous and SDLC modes, this bit indicates the result of comparing the CRC checker to the appropriate check value. This bit is reset by issuing an Error Reset command, but the bit is never latched. Therefore, it is always updated when the next character is received. When used for CRC error status in Synchronous or SDLC modes, this bit is usually set since most bit combination, except for a correctly completed message, result in a non-zero CRC.

REGISTERS DESCRIPTION (cont'd)

Figure 60 : Read Register 1.

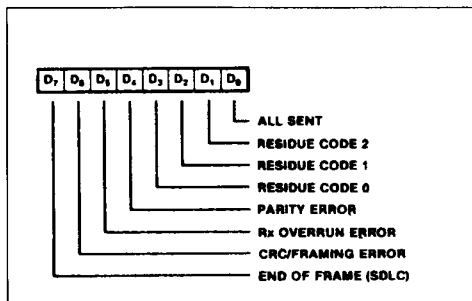
**Bit 5 : Receiver Overrun Error**

This bit indicates that the receive FIFO has overflowed. Only the character that has been written over is flagged with this error, and when the character is read, the Error condition is latched until reset by the Error Reset command. The overrun character and all subsequent characters received until the Error Reset command is issued causes a Special Receive Condition vector to be returned.

Bit 4 : Parity Error

When parity is enabled, this bit is set for the characters whose parity does not match the programmed sense (even/odd). This bit is latched so that once an error occurs, it remains set until the Error Reset command is issued. If the parity in Special Condition bit is set, a parity error causes a Special Receive Condition vector to be returned on the character containing the error and on all subsequent characters until the Error Reset command is issued.

Bit 3,2, and 1 : Residue Codes 2,1, And 0

In those cases in SDLC mode where the received I-Field is not an integral multiple of the character length, these three bits indicate the length of the I-Field and are meaningful only for the transfer in which the end of frame bit is set. This field is set to "011" by a channel or hardware reset and is forced to this state in Asynchronous mode. These three bits can leave this state only if SDLC is selected and a character is received. The codes signify the following (Reference Table 16 when a receive character length is eight bits per character).

I-Field bits are right-justified in all cases. If a receive character length other than eight bits is used for the I-Field, a table similar to Table 16 can be constructed for each different character length. Table 17

shows the residue codes for no residue (The I-Field boundary lies on a character boundary).

Table 16 : I-Field Bit Selection (8 Bits only).

Residue	Residue	Residue	I-Field Bits in Last Byte	I-Field Bits in Previous Byte
1	0	0	0	3
0	1	0	0	4
1	1	0	0	5
0	0	1	0	6
1	0	1	0	7
0	1	1	0	8
1	1	1	1	8
0	0	0	2	8

Bit 0 : All Sent

In Asynchronous mode, this bit is set when all characters have completely cleared the transmitter pins. Most modems contain additional delays in the data path, which requires the modem control signals to remain active until after the data has cleared both the transmitter and the modem. This bit is always set in synchronous and SDLC modes.

Table 17 : Residue Bits/Character.

Bits / Char	Residue	Residue	Residue
8	0	1	1
7	0	0	0
6	0	1	0
5	0	0	1

Read Register 2. RR2 contains the interrupt vector written into WR2. When the register is accessed in Channel A, the vector returned is the vector actually stored in WR2. When this register is accessed in Channel B, the vector returned includes status information in bits 1, 2, and 3, or in bits 6, 5, and 4, depending on the state of the Status High/Status Low bit in WR9 and independent of the state of the VIS bit in WR9. The vector is modified according to Table 11 shown in the explanation of the VIS bit in WR9. If no interrupts are pending, the status is V3, V2, V1 = 011, or V6, V5, V4 = 110. Figure 61 shows the bit positions for RR2.

Read Register 3. RR3 is the Interrupts Pending register. The status of each of the Interrupt Pending bits in the SCC is reported in this register. This register exists only in Channel A. If this register is accessed in Channel B, all "0s" are returned. The two unused bits are always returned as "0". Figure 62 shows the bit positions for RR3.

REGISTERS DESCRIPTION (cont'd)

Read Register 8. RR8 is the Receive Data register.

Read Register 10. RR10 contains some miscellaneous status bits. Unused bits are always "0". Bit positions for RR10 are shown in Figure 63.

Bit 7 : One Clock Missing

While operating in the FM mode, the DPLL sets this bit to "1" when it does not see a clock edge on the incoming lines in the window where it expects one. This bit is latched until reset by a Reset Missing Clock or Enter Search Mode command in WR14. In the NRZI mode of operation and while the DPLL is disabled, this bit is always "0".

Bit 6 : Two Clocks Missing

While operating in the FM mode, the DPLL sets this bit to "1" when it does not see a clock edge in two successive tries. At the same time the DPLL enters the Search mode. This bit is latched until reset by a Reset Missing Clock or Enter Search Mode command in WR10. In the NRZI mode of operation and while the DPLL is disabled, this bit is always "0".

Bit 4 : Loop Sending

This bit is set to "1" in SDLC Loop mode while the transmitter is in control of the Loop, that is, while the

SCC is actively transmitting on the loop. This bit is reset at all other times.

This bit can be polled in SDLC mode to determine when the closing flag has been sent.

Bit 1 : On Loop

This bit is set to "1" while the SCC is actually onloop in SDLC Loop mode. This bit is set to "1" in the X.21 mode (Loop mode selected while in monosync) when the transmitter goes active. This bit is "0" at all other times. This bit can also be pulled in SDLC mode to determine when the closing flag has been sent.

Read Register 12. RR12 returns the value stored in WR12, the lower byte of the time constant for the baud rate generator. Figure 64 shows the bit positions for RR12

Read Register 13. RR13 returns the value stored in WR13, the upper byte of the time constant for the baud rate generator. Figure 65 shows the bit positions for RR13.

Read Register 15. RR15 reflects the value stored in WR15, the External/Status IE bits. The two unused bits are always returned as "0s". Figure 66 shows the bits positions for RR15.

Figure 61 : Write Register 2.

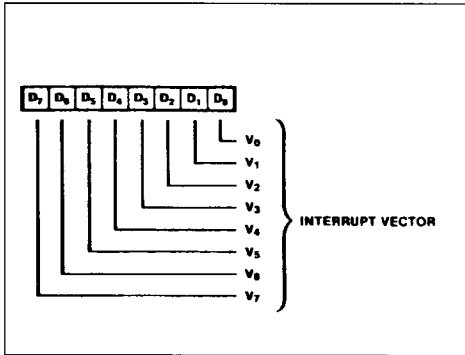
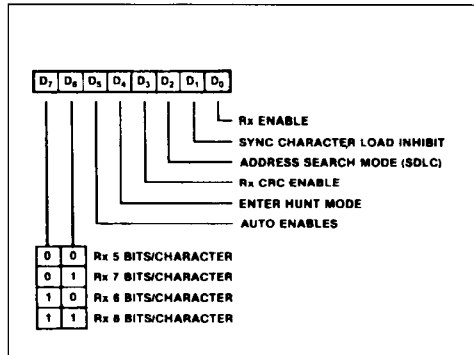

Figure 62 : Write Register 3.



REGISTERS DESCRIPTION (cont'd)

Figure 63 : Write Register 10.

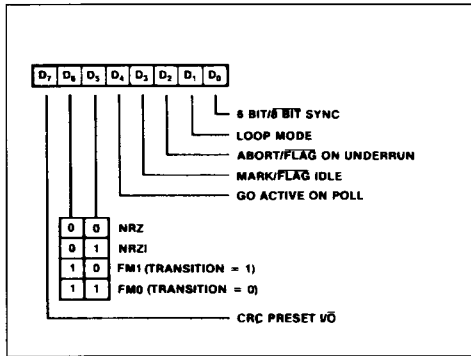

Figure 64 : Write Register 12.

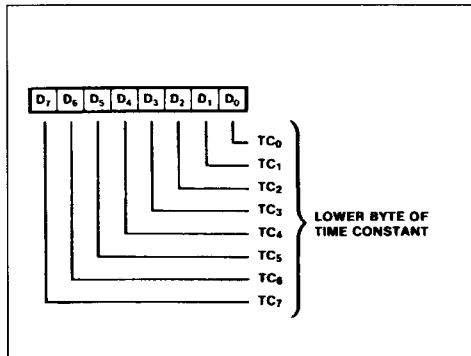

Figure 65 : Write Register 13.

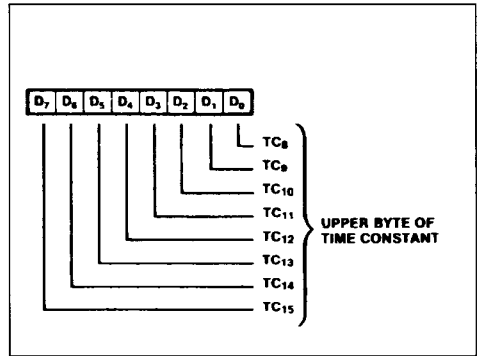
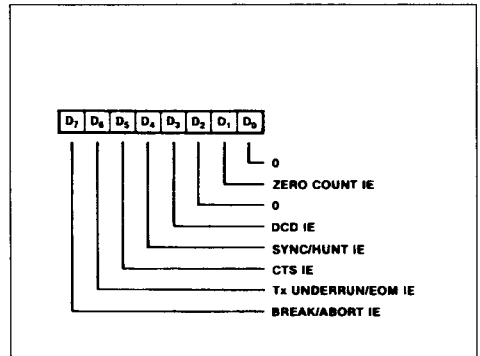

Figure 66 : Write Register 15.



SCC INITIALIZATION WORKSHEET

This section describes the software initialization procedure for the Serial Communications Controller (SCC).

Figure 68 provides a worksheet that can be used as an aid when initializing the SCC. Since all SCC operation modes are initialized in a similar manner, the worksheet can be used to tailor the SCC device to the user's individual need. Specific examples are given in the following sections.

Register Overview

Each of the SCC's two channels has its own separate Write registers that are programmed to initialize different operating modes. There are two types of bits in the Write registers: Command bits and Mode bits. An example of a register that contains both types of bits is Write Register 9 (WR9), and is shown in figure 67.

Figure 67 : Write Register 2.

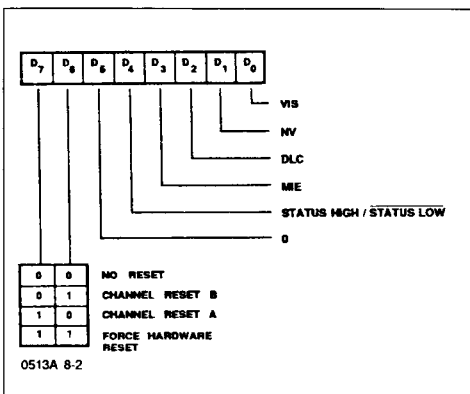

WR9 is the Master Interrupt Control register and contains the Reset command bits. Command bits are denoted by having boxes drawn around them in register diagrams. Bit D5 in this register is not used in this register and must be 0 at all times.

The Command bits, D7 and D6, select one of the reset commands for the SCC. Setting either of these bits to 1 disables both the receiver and the transmitter in the corresponding channel, forces Tx/D for the channel marking, forces the modem control signals High in that channel, resets all IPs and IUSs, and di-

sables all interrupts in that channel. Functions controlled by the Command bits can only be enabled or disabled, they cannot be toggled.

Bits D4-D0 are Mode bits that can be enabled or disabled either by being set to "1" or reset to "0". Each Mode bit affects only one function. For example, Bit D1 is the No Vector mode bit, it controls whether or not the SCC will respond to an interrupt acknowledge cycle by placing a vector on the data bus. If this bit is set, no vector is returned. In command bits entry, each new command requires a separate rewrite of the entire register. Care must be taken when issuing a command, so that the Mode bits are not changed accidentally.

Initialization Procedure

The SCC initialization procedure is divided into three parts. The first part consists of programming the operation modes (e.g. bits-per-character, parity) and loading the constants (e.g., interrupt vector, time constants). The second part enables the hardware functions (e.g., transmitter, receiver, baud-rate generator). It is important that the operating modes are programmed before the hardware functions are enabled. The third part, if required, consists of enabling the different interrupts.

Table 18 shows the order (from top to bottom) in which the SCC registers are to be programmed. Those registers that need not be programmed are listed as optional in the comments column. The bits in the registers that are marked with an "X" are to be programmed by the user. The bits marked with an "S" are to be set to their previous programmed value. For example, in part 2, Write Register 3, bits D1-D7 are shown with an "S" because they have been programmed in part 1 and must remain set to the same value.

Initialization Table Generation

Figure 68 is a worksheet for the initialization of the SCC. All the bits that must be programmed as either a "0" or a "1" are already filled in; the remaining bits are left blank and are to be programmed by the user according to the desired mode of operation. The binary value can then be converted to a hexadecimal number and placed in the table, following the Write register notation in the column labeled "HEX". A Program Initialization Table is produced when this worksheet is completed.

SCC INITIALIZATION WORKSHEET (cont'd)

Figure 68 : SCC Initialization Worksheet.

Label of SCC Table: _____ SCC Base Address _____

Description: _____

REGISTER	HEX	BINARY								COMMENTS		
		7	6	5	4	3	2	1	0			
MODES	WR0	C 0	1	1	0	0	0	0	0	0	SOFTWARE RESET	
	WR0	0	0	0	0	0	0	0	0			
	WR4											
	WR1		0			0	0		0	0		
	WR2											
	WR3									0		
	WR5						0					
	WR6											
	WR7											
	WR8		0	0	0		0					
	WR10											
	WR11											
	WR12											
	WR13											
ENABLES	WR14									0		
	WR14									0		
	WR14		0	0	0						1	
	WR5						1					
INTERRUPT	WR0	0 0	1	0	0	0	0	0	0	1	0	RESET TxCRC
	WR1											
	WR16											
	WR0	1 0	0	0	0	1	0	0	0	0	0	RESET ExtvSTATUS
WR0	1 0	0	0	0	1	0	0	0	0	0	RESET ExtvSTATUS	
WR1												
WR9		0	0	0								

SCC INITIALIZATION WORKSHEET (cont'd)

Table 18 : SCC Initialization Order.

Part 1. Modes and Constants		
WR9	1100000	Hardware Reset
WR0	000000XX	Select Shift Mode (8030 only)
WR4	XXXXXXXX	Tx/Rx Con, Async or Sync Mode
WR1	0XX00X00	Select W/REQ (opt)
WR2	XXXXXXXX	Program Interrupt Vector (opt)
WR3	XXXXXXXX	Select Rx Control
WR5	XXXX0XXX	Selects Tx Control
WR6	XXXXXXXX	Program Sync Character (opt)
WR7	XXXXXXXX	Program Sync Character (opt)
WR9	000X0XXX	Select Interrupt Control
WR10	XXXXXXXX	Miscellaneous Control (opt)
WR11	XXXXXXXX	Clock Control
WR12	XXXXXXXX	Time Constant Lower Byte (opt)
WR13	XXXXXXXX	Time Constant Upper Byte (opt)
WR14	XXXXXX0	Miscellaneous Control
WR14	XXXXSSSS	Commands (opt)

Reset Conditions

Prior the initialization, the SCC should be reset by either hardware or software. A hardware reset can

POLLED ASYNCHRONOUS MODE

This section describes the use of the SCC in polled Asynchronous Mode. The device can be set with 5 to 8 bits per character, 1, 1.5, or 2 stop bits, and a wide range of baud rates. In this particular example, 8 bits per character, 2 stop bits and 9600 baud rate are used. An external 2.4576MHz, crystal oscillator is used for baud-rate generation. The SCC can be programmed for local loopback for on-board diagnostics. The user can make use of this feature to test-program the part without additional hardware to simulate an actual transmit and receive environment.

SCC Interface

Figure 69 shows the SCC to CPU interface required for this application. The 8-bit data bus and control lines all come from the user's CPU. The 8530 control lines are RD, WR, A/B, D/C and CE. PCLK comes from the system clock, or an external crystal, up to the maximum rate of the SCC (ex. 6MHz for the Z8530A). The IEI and the INTACK pins should be pulled up. The baud-rate generator clock is connected to the RTxC pin.

SCC Initialization

Initialization of the SCC for polled asynchronous communication is divided into two parts ; part one programs the operating modes of the SCC and part two enables them. Care must be taken when writing

Part 2. Enables		
WR14	000SSSS1	Baud Rate Enable
WR3	SSSSSSS1	Rx Enable
WR5	SSSS1SSS	Tx Enable
WR0	10000000	Reset Tx CRG (opt)
WR1	XSS00S00	DMA Enable (opt)
Part 3. Interrupt Status		
WR15	XXXXXXXX	Enable External/status
WR0	00010000	Reset External Status
WR0	00010000	Reset External Status Twice
WR1	SSSXSXX	Enable Rx, Tx and Ext/status
WR9	000XSSS	Enable Master Interrupt Enable
1 = Set to one 0 = Reset to zero		X = User defined S = Same as previously prog.

be accomplished by simultaneously grounding. A software reset can be executed by writing a 0H to Write Register 9.

the software to meet the SCC's Cycle and Reset Recovery times. The Cycle Recovery time, 6 PCLK cycles, applies to the period between any Read or Write cycles affecting the SCC. The Reset Recovery time is the period after a hardware reset caused either by hardware or software ; this recovery time extends the Cycle Recovery time to 11 PCLK cycles. For more details about these recovery times, see the section Interfacing the SCC.

Table 19 : Polled Asynchronous Initialization Procedure.

Register	Value	Comments
WR9	C0H	Force Hardware Reset
WR4	4CH	x16 Clock, 2 Stop Bits, no Parity
WR3	C0H	Rx8 Bits, Rx Disabled
WR5	60H	Tx8 Bits, DTR, RTS, Tx off
WR9	00H	Int. Disabled
WR10	00H	NRZ
WR11	56H	Tx & Rx = BRG out, TRxC = BRG out
WR12	06H	Time Constant = 6
WR13	00H	Time Constant High = 0
WR14	10H	BRG in = RTxC, BRG off, Loopback
Enables		
WR14	11H	BRG Enable
WR3	C1H	Rx Enable
WR5	68H	Tx Enable

POLLED ASYNCHRONOUS MODE (cont'd)

Figure 69.

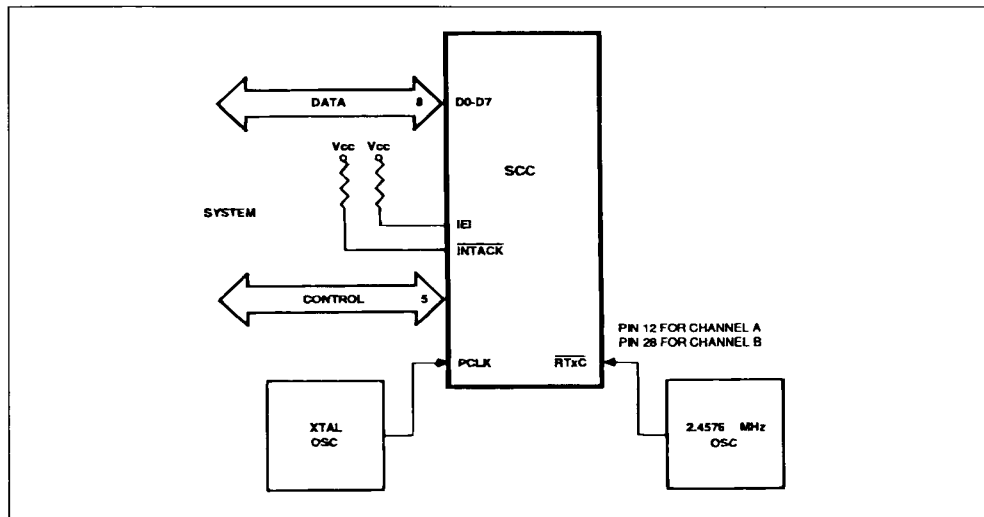
**SCC Operating Mode Programming**

WR9 resets the SCC to a known state by writing a C0 hex. The command, Force Hardware Reset, is identical to a hardware reset.

WR4 selects the asynchronous, x 16 mode, with 2 stop bits and no parity. The x 16 mode means that clock rate is 16 times the data rate.

WR3 selects 8 bits per character and does not enable the receiver. The 8 bits per character allows 8 bits to be assembled from the data stream. The receiver is not enabled at this time because the SCC has not been initialized.

WR5 selects 8 bits per character and does not enable the transmitter. The 8 bits per character allows 8 bits to be sent, as data, with the least significant bit first. The transmitter is not enabled at this time because the SCC has not been initialized.

WR9 selects that there are no interrupts enabled. This inhibits the SCC from requesting an interrupt from the CPU.

WR10 selects NRZ encoding. This NRZ coding is used on the transmitter as well as the receiver.

WR11 selects the \overline{RTxC} pin to TTL clock; the baud-rate generator is the transmit and receive clocks source, and the \overline{TRxC} pin as a baud-rate generator output.

WR12 & WR13 and select the baud-rate generator's

time constant. The WR13 time constant is determined by the equation :

$$\text{Time Constant} = \frac{\text{Clock Frequency}}{2 \times \text{Baud Rate} \times \text{clock mode}} - 2$$

In this example, the clock frequency is 2.4576MHz, the baud rate is 9600, and the clock mode is 16, the time constant is, therefore, 6; expressed as a 16-bit, hexadecimal number, it is 0006H. The time constant LOW (WR12) is, therefore, 06H and the time constant HIGH (WR13) is 00H. The baud rate for this example can be varied, as long as the data rate is less than 1/4 of the PCLK rate.

Table 20 shows the time constants for other common baud rates.

Table 20 : Time Constants for Common Baud Rates.

Baud Rate	Divider	
	Decimal	Hex
38400	0	0000H
19200	2	0002H
9600	6	0006H
4800	14	000EH
2400	30	001EH
1200	62	003EH
600	126	007EH
300	254	00FEH
150	510	01FEH

For 2.4576 MHz Clock, X 16 Mode

POLLED ASYNCHRONOUS MODE (cont'd)

WR14 selects the baud-rate generator as the $\overline{RTx\overline{C}}$ pin, baud-rate generator disabled, and internal loop-back. The baud-rate generator uses the $\overline{RTx\overline{C}}$ pin as the clock source and is not enabled at this time because the SCC initialization is not complete.

SCC Operating Mode Enables

WR14 enables the baud-rate generator. Bit 0 (LSB) is changed to a 1 to enable the baud-rate generator ; all other bits must maintain the value selected during initialization.

WR3 enables the receiver. Bit 0 (LSB) is changed to a 1 to enable the receiver, all other bits must maintain the value selected during initialization.

WR5 enables the transmitter. Bit 3 is changed to a 1 to enable the transmitter, all other bits must maintain the value selected during initialization.

Transmit and Receive Routines

After initialization, and after all enables have been selected, the SCC is ready for communication.

The transmitter buffer and the receive FIFO are empty. The example shown below is coded to transmit and receive characters.

Figure 70 : Transmit and Receive Routine.

```

; Transmit a character
TXCHAR : INPUT    RRO      ;Read RRO
          Test     Bit 2    ;Test transmit
                               buffer empty
          JZ       TXCHAR   ;Loop if not
                               empty
          OUTPUT   CHAR     ;Output chara
                               cter to data port
          RET

; Receive a character
RXCHAR : INPUT    RRO      ;Read RRO
          TEST     BIT 0    ;Test Receive
                               buffer
          JZ       RXCHAR   ;Loop if not
                               full
          INPUT    CHAR     ;Input charac
                               ter from data
                               port
          RET           ; Return
    
```

Figure 71.

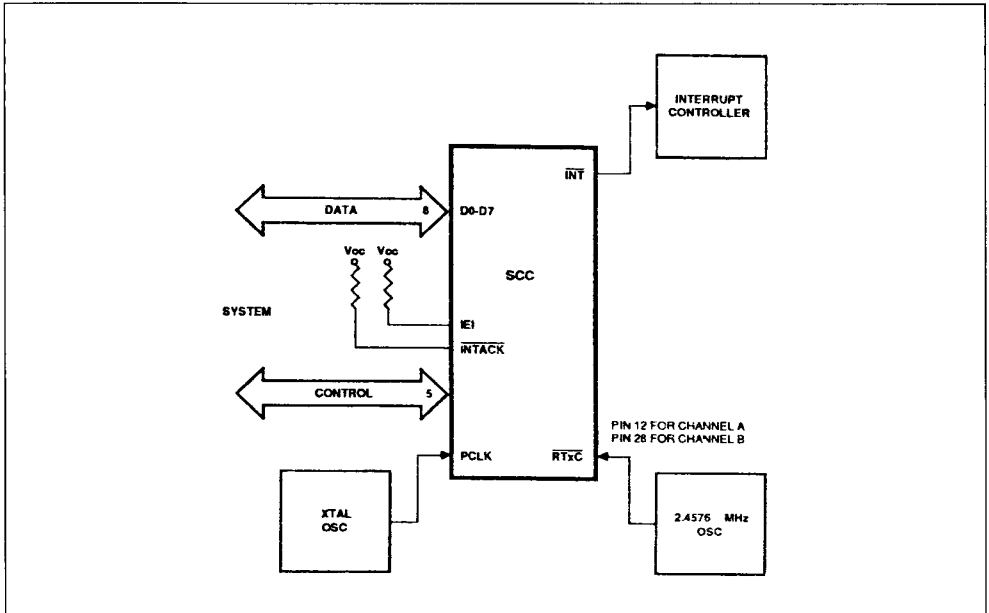

INTERRUPT WITHOUT INTACK ASYNCHRONOUS MODE

This section describes the use of the SCC for interrupt-driven Asynchronous Mode. As with the example in the previous chapter, the SCC is set with 8 bits per character, 2 stop bits, at 9600 baud rate. An external 2.4576MHz, crystal oscillator is used for baud-rate generation. Interrupt acknowledge is not generated because of the extra hardware required to produce this signal. In this chapter, the SCC is also programmed for local loopback so that no external loop between the transmit and the receive data lines is needed for on-board diagnostics. This feature allows the user to test-program the part without additional hardware to simulate an actual transmit and receive environment.

SCC Interface

Figure 71 shows the SCC to CPU interface required for this application. The 8-bit data bus and control lines all come from the user's CPU. For the 8530, the control lines are \overline{RD} , \overline{WR} , A/\overline{B} , D/\overline{C} and \overline{CE} . The \overline{INT} signal goes to an interrupt controller which must produce the interrupt vector to the CPU. The \overline{PCLK} comes from the system clock, or an external crystal oscillator, up to the maximum rate of the SCC (ex. 6MHz for the Z8530A). The \overline{IEI} and the \overline{INTACK} pins should be pulled up. The baud-rate generator clock is connected to the \overline{RTxC} pin.

SCC Initialization

The initialization of the SCC for interrupt-driven asynchronous communication is divided into three parts. Part one programs the operating modes of the SCC, part two and three enable them. Care must be taken when writing the code to meet the SCC's Cycle and Reset Recovery times. The Cycle Recovery time applies to the period between any Read or Write cycles to the SCC, and is 6PCLK cycles. The Reset Recovery time applies to a hardware reset caused either by hardware or software; this recovery time extends the Cycle Recovery time to 11PCLK cycles. More details about these recovery times can be found in the section Interfacing the SCC.

Table 21.

Register	Value	Comments
WR9	C0H	Force Hardware Reset
WR4	4CH	x16 Clock, 2 Stop Bits, no Parity
WR2	00H	Interrupt Vector 00WR3
	C0H	Rx8 Bits, Rx Disabled
WR5	60H	Tx8 Bits, DTR, RTS, Tx off
WR9	00H	Int. Disabled WR10
	00H	NRZ
WR11	56H	Tx & Rx = BRG out, TRxC = BRG out
WR12	06H	Time Constant = 6
WR13	00H	Time Constant High = 0
WR14	10H	BRG in = RTxC, BRG off, Loopback
Enables		
WR14	11H	BRG Enable
WR3	C1H	Rx Enable
WR5	68H	Tx Enable
Enable Interrupts		
WR1	12H	Rx Int on All Char and Tx Int Enables
WR9	08H	MIE

SCC Operating Modes Programming

WR9 resets the SCC to a known state by writing a C0 hex. This command, Force Hardware Reset, is identical to a hardware reset.

WR4 selects asynchronous mode, x16 mode, 2 stop bits and no parity. The x16 mode means that the clock rate is 16 times the data rate.

WR2 is the interrupt vector of the SCC. Even though a vector is not placed on the bus in this mode the vector including status in read from RR2. By writing 00H to this register the status read will be the only bits set in RR2.

WR3 selects 8 bits per character and does not enable the receiver. The 8 bits per character allows 8 bits to be assembled from the data stream. The receiver is not enabled at this time because the SCC is not completely initialized.

WR5 selects 8 bits per character and does not

INTERRUPT WITHOUT INTACK ASYNCHRONOUS MODE (cont'd)

enable the transmitter. The 8 bits per character allows 8 bits to be sent as data with the least significant bit first. The transmitter is not enabled at this time because the SCC is not completely initialized.

WR9 selects that there are no interrupts enabled. This will inhibit the SCC from requesting an interrupt from the CPU.

WR10 selects NRZ encoding. This selects NRZ coding is to be used on the transmitter and the receiver.

WR11 selects the RTxC pin to TTL clock, the transmit and receive clocks source as the baud-rate generator and the TRxC pin as a baud-rate generator output.

WR12 & WR13 select the baud-rate generators time constant. The time constant is determined by the equation :

$$\text{Time Constant} = \frac{\text{Clock Frequency}}{2 \times \text{Baud Rate} \times \text{clock mode}} - 2$$

In this example, the clock frequency is 2.4576MHz, the baud rate is 9600, and the clock mode is 16 ; the time constant is 6. Converting this time constant to a 16-bit hexadecimal number, it becomes 0006H. The time constant LOW (WR12) is 06H and the time constant HIGH (WR13) is 00H. The baud rate for this example can be varied for as long as the data rate is less than 1/4 of the PCLK rate. Table 22 gives the time constants for other common baud rates.

Table 22 : Time Constants for Common Baud Rates.

Baud Rate	Divider	
	Decimal	Hex
38400	0	0000H
19200	2	0002H
9600	6	0006H
4800	14	000EH
2400	30	001EH
1200	62	003EH
600	126	007EH
300	254	00FEH
150	510	01FEH

For 2.4576 MHz Clock, X 16 Mode

WR14 selects the baud rate source as the $\overline{\text{RTxC}}$ pin, baud rate generator disabled, and internal loop-back. The baud-rate generator will use the RTxC pin as the clock source for the baud-rate generator. The baud-rate generator is not enabled at this time because the SCC initialization is not complete.

SCC Operating Mode Enables

WR14 enables the baud-rate generator. Bit 0 (LSB) is changed to a 1 to enable the baud-rate generator ; all other bits must maintain the value selected during initialization.

WR3 enables the receiver. Bit 0 (LSB) is changed to a 1 to enable the receiver ; all other bits must maintain the value selected during initialization.

WR5 enables the transmitter. Bit 3 is changed to a 1 to enable the transmitter ; all other bits must maintain the value selected during initialization.

SCC Operating Mode Interrupts

WR1 enables the Tx and the Rx interrupts. The Rx interrupt is programmed to generate an interrupt an all received characters or special conditions. This provides an interrupt on every character received by the SCC. The external/status interrupts are not enabled in this application.

WR9 sets the master interrupt enable (MIE) bit 3. Setting this bit enables the interrupts pending to generate and interrupt on the INT pin.

Interrupt Routine

When the SCC has been initialized and enabled, it is ready for communication. The transmitter buffer and the receive FIFO are both empty. An interrupt will not be generated until the software writes the first character to the transmit buffer. Once the first character is in the SCC shift register, the first transmit interrupt will occur. The SCC will then keep setting transmit and receive interrupts to the interrupt controller until the end of the message. At the end of the message, a Reset Transmitter Interrupt Pending (WR0) is issued to clear the transmit interrupt. After the last character is read into the SCC, the interrupts will cease until another message is written into the transmitter.

Once an interrupt is received and the interrupt controller vectors to the interrupt routine, RR2 is read from channel B. The value read from RR2 is the vector, including status. This vector shows the status of the highest priority interrupt pending (IP) at the time it is read. Once the highest priority interrupt condition is cleared, RR2 will show the status of the next highest interrupt pending, if one is present. This allows multiple interrupts to be serviced without the overhead of the interrupt acknowledge cycle of the interrupt controller.

The following example shows how the interrupt routine should be coded.

HARDWARE INFORMATION

Absolute Maximum Ratings

Parameter	Test Conditions	Unit
Operating Temperature Z8530 B1/D1/C1 B6/D6/C6	0 to + 70	°C
	- 40 to + 85	°C
Storage Temperature	- 65 to + 150	°C
Voltages on any Pin with Respect to GND	- 0.3 to + 7	V
Total Power Dissipation	700	mW
Oscillator Frequency Z8530 Z8530A Z8530B	0 to 4	MHz
	0 to 6	
	0 to 8	

Note : Stresses above those listed under "Absolute Maximum Ratings" may cause permanent damage to the device. This is a stress rating only and functional operation of the device at these or any other conditions above those indicated in the operational sections of these specifications is not implied. Exposure to absolute maximum rating conditions for extended periods may affect device reliability.

Test Conditions

The characteristics below apply for the following standard test conditions, unless otherwise noted. All voltages are referenced to GND. Positive current flows into the reference pin.

Standard conditions are as follows :

- + 4.75 V \leq V_{CC} \leq + 5.25 V
- GND = 0 V
- 0 °C \leq T_A \leq + 70 °C

All ac parameters assume a load capacitance of 50 pF max.

Figure 73 : Standard Test Load.

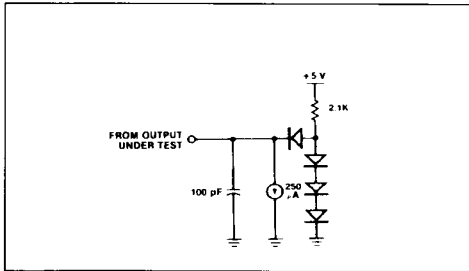
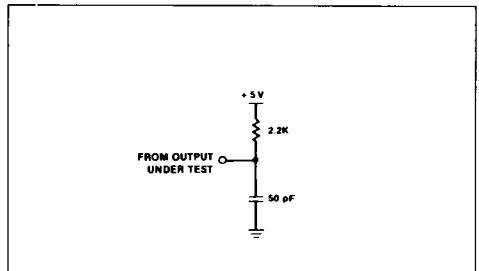

Figure 74 : Open-Drain Test Load.



DC Characteristics

Symbol	Parameter	Test Conditions	Min.	Max.	Unit
V _{IH}	Input High Voltage		2.0	V _{CC} +0.3	V
V _{IL}	Input Low Voltage		- 0.3	0.8	V
V _{OH}	Output High Voltage	I _{OH} = - 250 μA	2.4		V
V _{OL}	Output Low Voltage	I _{OL} = + 2.0 mA		0.4	V
I _{IL}	Input Leakage	0.4 \leq V _{IN} \leq + 2.4 V		± 10.0	μA
I _{OL}	Output Leakage	0.4 \leq V _{OUT} \leq + 2.4 V		± 10.0	μA
I _{CC}	V _{CC} Supply Current		250		mA

V_{CC} = 5 V \pm 5 % unless otherwise specified, over specified temperature range.

HARDWARE INFORMATION (cont'd)

Capacitance

Symbol	Parameter	Test Conditions	Min.	Max.	Unit
C _{IN}	Input Capacitance			10	pf
C _{OUT}	Output Capacitance			15	pf
C _{I/O}	Bidirectional Capacitance			20	pf

f = 1 MHz, over specified temperature range.
 Unmeasured pins returned to ground.

AC Timing Characteristics

Figure 75 : Read and Write Timing.

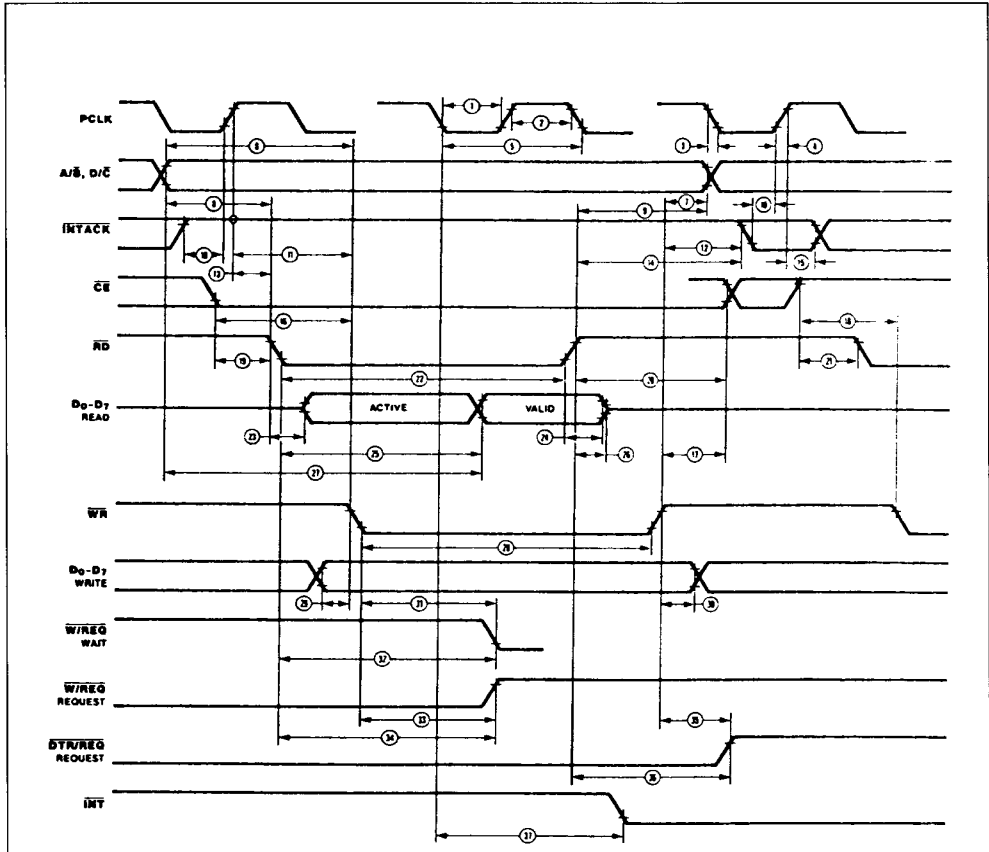

HARDWARE INFORMATION (cont'd)

Table 23 : AC Timing Characteristics.

N°	Symbol	Parameter	Z8530		Z8530A		Z8530B		Notes*
			Min. (ns)	Max. (ns)	Min. (ns)	Max. (ns)	Min. (ns)	Max. (ns)	
1	TwPC1	PCLK Low Width	105	2000	70	1000	50	1000	
2	TwPCh	PCLK High Width	105	2000	70	1000	50	1000	
3	TfPC	PCLK Fall Time		20		10		10	
4	TrPC	PCLK Rise Time		20		15		10	
5	TcPC	PCLK Cycle Time	250	4000	165	2000	125	2000	
6	TsA(WR)	Address to \overline{WR} ↓ Setup Time	80		80		70		
7	ThA(WR)	Address to \overline{WR} ↑ Hold Time	0		0		0		
8	TsA(RD)	Address to \overline{RD} ↓ Setup Time	80		80		70		
9	ThA(RD)	Address to \overline{RD} ↑ Hold Time	0		0		0		
10	TsIA(PC)	\overline{INTACK} to PCLK ↑ Setup Time	10		10		10		
11	TsIAi(WR)	\overline{INTACK} to \overline{WR} ↓ Setup Time	200		160		145		1
12	ThIA(WR)	\overline{INTACK} to \overline{WR} ↑ Hold Time	0		0		0		
13	TsIAi(RD)	\overline{INTACK} to \overline{RD} ↓ Setup Time	200		160		145		1
14	ThIA(RD)	\overline{INTACK} to \overline{RD} ↑ Hold Time	0		0		0		
15	ThIA(PC)	\overline{INTACK} to PCLK ↑ Hold Time	100		100		85		
16	TsCE1(WR)	\overline{CE} Low to \overline{WR} ↓ Setup Time	0		0		0		
17	ThCE(WR)	\overline{CE} to \overline{WR} ↑ Hold Time	0		0		0		
18	TsCEh(WR)	\overline{CE} High to \overline{WR} ↓ Setup Time	100		70		60		
19	TsCE1(RD)	\overline{CE} Low to RD ↓ Setup Time	0		0		0		1
20	ThCE(RD)	\overline{CE} to RD ↑ Hold Time	0		0		0		1
21	TsCEh(RD)	\overline{CE} High to RD ↓ Setup Time	100		70		60		1
22	TwRD1	\overline{RD} Low Width	240		200		150		1
23	TdRD(DRA)	\overline{RD} ↓ to Read Data Active Delay	0		0		0		
24	TdRD(rDR)	\overline{RD} ↑ to Read Data Not Valid Delay	0		0		0		
25	TdRDf(DR)	\overline{RD} ↓ to Read Data Valid Delay		250		180		140	
26	TdRD(DRz)	\overline{RD} ↑ to Read Data Float Delay		70		45		40	2

- Notes :
- Parameter does not apply to Interrupt Acknowledge transactions.
 - Float delay is defined as the time required for a ± 0.5 V change in the output with a maximum dc load and minimum ac load.
- * Timings are preliminary and subject to change.

HARDWARE INFORMATION (cont'd)

Figure 76 : Interrupt Acknowledge Timing.

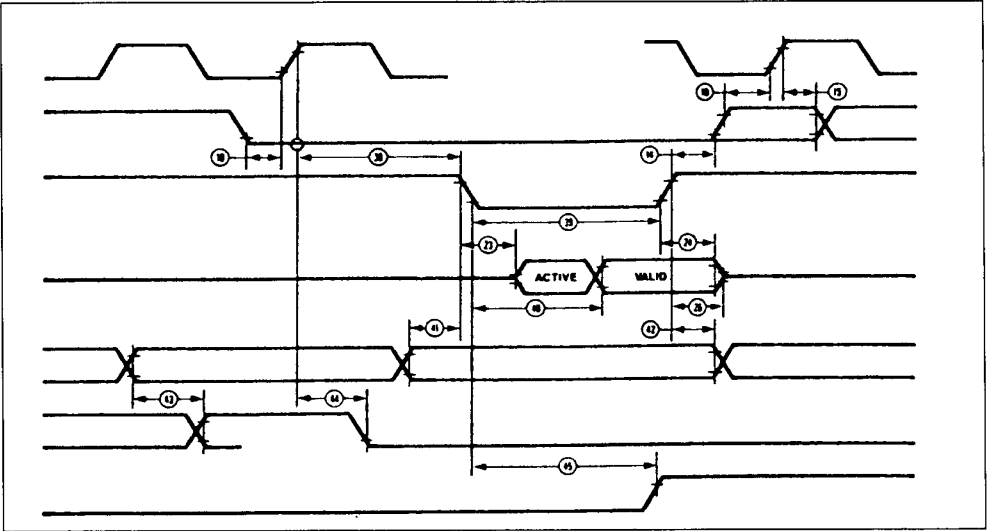

Figure 77 : Reset Timing.

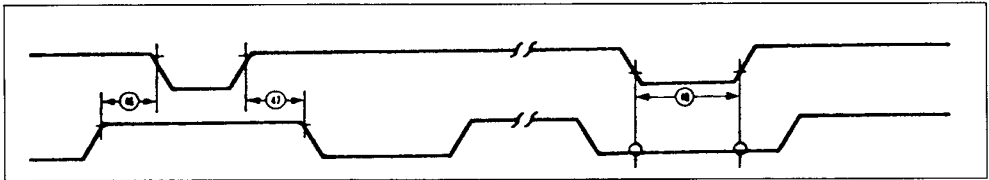
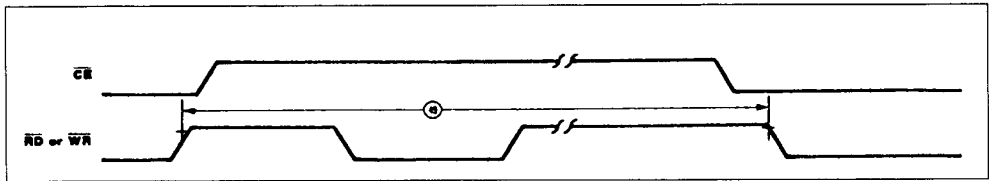

Figure 78 : Cycle Timing.



HARDWARE INFORMATION (cont'd)

Table 24 : AC Timing Characteristics.

N°	Symbol	Parameter	Z8530		Z8530A		Z8530B		Notes*
			Min. (ns)	Max. (ns)	Min. (ns)	Max. (ns)	Min. (ns)	Max. (ns)	
27	TdA(DR)	Address Required Valid to Read Data Valid Delay		300		280		220	
28	TwWR1	WR Low Width	240		200		150		
29	TsDW(WR)	Write Data to WR ↓ Setup Time	10		10		10		
30	ThDW(WR)	Write Data WR ↑ Hold Time	0		0		0		
31	TdWR(W)	WR ↓ to Wait Valid Delay		240		200		170	4
32	TdRD(W)	RD ↓ to Wait Valid Delay		240		200		170	4
33	TdWRf(REQ)	WR ↓ to W / REQ Not Valid Delay		240		200		170	
34	TdRDr(REQ)	RD ↓ to W / REQ Not Valid Delay		240		200		170	
35	TdWRr(REQ)	WR ↑ to DTR / REQ Not Valid Delay		4TcPC		4TcPC		4TcPC	
36	TdRDr(REQ)	RD ↑ to DTR / REQ Not Valid Delay		4TcPC		4TcPC		4TcPC	
37	TdPC(INT)	PCLK ↓ to INT Valid Delay		500		500		500	4
38	TdIAi(RD)	INTACK to RD ↓ (Acknowledge) Delay	250		200		150		5
39	TwRDA	RD (Acknowledge) Width	250		200		150		
40	TdRDA(DR)	RD ↓ (Acknowledge) to Read Data Valid Delay		250		180		140	
41	TsIEI(RDA)	IEI to RD ↓ (Acknowledge) Setup Time	120		100		95		
42	ThIEI(RDA)	IEI to RD ↑ (Acknowledge) Hold Time	0		0		0		
43	TdIEI(IEO)	IEI to IEO Delay Time		120		100		95	
44	TdPC(IEO)	PCLK ↑ to IEO Delay		250		250		200	
45	TdRDA(INT)	RD ↓ to INT Inactive Delay		500		500		450	4
46	TdRD(WRQ)	RD ↑ WR ↓ Delay for No Reset	30		15		15		
47	TdWRQ(RD)	WR ↑ to RD ↓ Delay for No Reset	30		30		20		
48	TwRES	WR and RD Coincident Low for Reset	250		200		150		
49	Trc	Valid Access Recovery Time	4TcPC		4TcPC		4TcPC		3

Notes : 3. Parameter applies only between transactions involving the SCC.

4. Open-drain output, measured with open-drain test load.

5. Parameter is system dependent. For any SCC in the daisy chain, TdIAi(RD) must be greater than the num of TdPC(IEO) for the highest priority device in the daisy chain, TsIEI(RDA) for the SCC, and TdIEI(IEO) for each device separating them in the daisy chain.

* Timings are preliminary and subject to change.

HARDWARE INFORMATION (cont'd)

Figure 79 : General Timing.

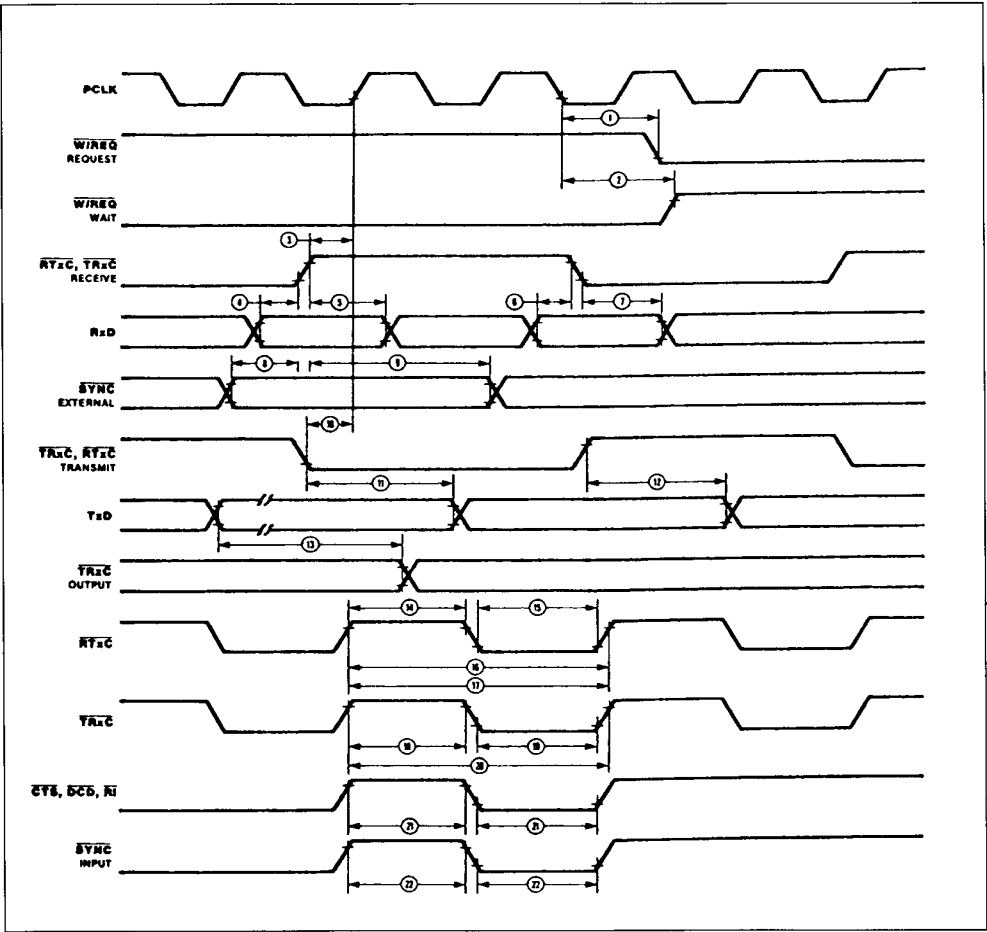

HARDWARE INFORMATION (cont'd)

Table 25 : General Timing Characteristics (cont'd).

N°	Symbol	Parameter	Z8530		Z8530A		Z8530B		Notes*
			Min. (ns)	Max. (ns)	Min. (ns)	Max. (ns)	Min. (ns)	Max. (ns)	
1	TdPC(REQ)	PCLK ↓ to \overline{W} / \overline{REQ} Valid Delay		250		250		250	
2	TdPC(W)	PCLK ↓ to Wait Inactive Delay		350		350		350	
3	TsRXC(PC)	\overline{RxC} ↑ to PCLK ↑ Setup Time (PCLK + 4 case only)	80	TwPCL	70	TwPCL	60	TwPCL	1.4
4	TsRXD(RXC _r)	RxD to \overline{RxC} ↑ Setup Time (X1 Mode)	0		0		0		1
5	ThRXD(RXC _r)	RxD to \overline{RxC} ↑ Hold Time (X1 Mode)	150		150		150		1
6	TsRXD(RXC _f)	RxD to \overline{RxC} ↓ Setup Time (X1 Mode)	0		0		0		1.5
7	ThRXD(RXC _f)	RxD to \overline{RxC} ↓ Hold Time (X1 Mode)	150		150		150		1.5
8	TsSY(RXC)	\overline{SYNC} to \overline{RxC} ↑ Setup Time	- 200		- 200		- 200		1
9	ThSY(RXC)	\overline{SYNC} to \overline{RxC} ↑ Hold Time	3TcPC + 400		3TcPC + 320		3TcPC + 250		1
10	TsTXC(PC)	\overline{TxC} ↓ to PCLK ↑ Setup Time	0		0		0		2.4
11	TdTXCf(TXD)	\overline{TxC} ↓ to TxD Delay (X1 Mode)		300		230		200	2
12	TdTXCr(TXD)	\overline{TxC} ↑ to TxD Delay (X1 Mode)		300		230		200	2.5
13	TdTXD(TRX)	TxD to \overline{TRxC} Delay (Send Clock Echo)		200		200		200	
14	TwRTXh	\overline{RTxC} High Width	180		180		150		6
15	TwRTX1	\overline{RTxC} Low Width	180		180		150		6
16	TcRTX	\overline{RTxC} Cycle Time	1000		640		500		6.7
17	TcRTXX	Crystal Oscillator Period	250	1000	165	1000	125	1000	3
18	TwTRXh	\overline{TRxC} High Width	180		180		150		6
19	TwTRX1	\overline{TRxC} Low Width	180		180		150		6
20	TcTRX	\overline{TRxC} Cycle Time	1000		640		500		6.7
21	TwEXT	\overline{DCD} or \overline{CTS} Pulse Width	200		200		200		
22	TwSY	\overline{SYNC} Pulse Width	200		200		200		

- Notes :
1. \overline{RxC} is \overline{RTxC} or \overline{TRxC} , whichever is supplying the receive clock.
 2. \overline{TxC} is \overline{TRxC} or \overline{RTxC} , whichever is supplying the transmit clock.
 3. Both \overline{RTxC} and \overline{SYNC} have 30 pF capacitors to ground connected to them.
 4. Parameter applies only if the data rate is one-fourth the PCLK rate. In all other cases, no phase relationship between \overline{RxC} and PCLK or \overline{TxC} and PCLK is required.
 5. Parameter applies only to FM encoding/decoding.
 6. Parameter applies only for transmitter and receiver : DPLL and baud rate generator timing requirements are identical to chip PCLK requirements.
 7. The maximum receive on transmit data is 1/4PCLK.
- * Timings are preliminary and subject to change.

HARDWARE INFORMATION (cont'd)

Figure 80 : System Timing.

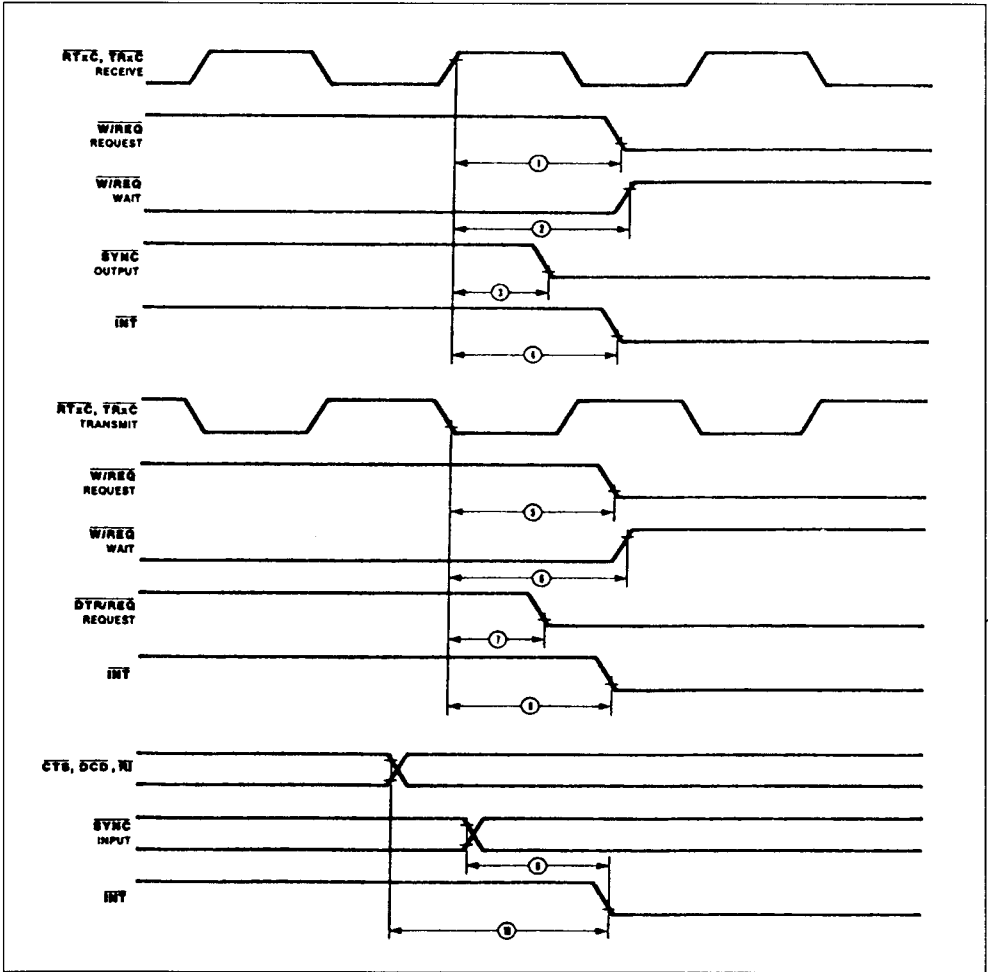

HARDWARE INFORMATION (cont'd)

Table 26 : System Timing Characteristics (cont'd).

N°	Symbol	Parameter	Z8530		Z8530A		Z8530B		Notes*
			Min.	Max.	Min.	Max.	Min.	Max.	
1	TdRXC(REQ)	$\overline{RxC} \uparrow$ to $\overline{W} / \overline{REQ}$ Valid Delay	8	12	8	12	8	12	2
2	TdRXC(W)	$\overline{RxC} \uparrow$ to Wait Inactive Delay	8	12	8	12	8	14	1.2
3	TdRXC(SY)	$\overline{RxC} \uparrow$ to \overline{SYNC} Valid Delay	4	7	4	7	4	7	2
4	TdRXC(INT)	$\overline{RxC} \uparrow$ to \overline{INT} Valid Delay	10	16	10	16	10	16	1.2
5	TdTXC(REQ)	$\overline{TxC} \downarrow$ to $\overline{W} / \overline{REQ}$ Valid Delay	5	8	5	8	5	8	3
6	TdTXC(W)	$\overline{TxC} \downarrow$ to Wait Inactive Delay	5	8	5	8	5	11	1.3
7	TdTXC(DRQ)	$\overline{TxC} \downarrow$ to $\overline{DTR} / \overline{REQ}$ Valid Delay	4	7	4	7	4	7	3
8	TdTXC(INT)	$\overline{TxC} \downarrow$ to \overline{INT} Valid Delay	6	10	6	10	6	10	1.3
9	TdSY(INT)	\overline{SYNC} Transition to \overline{INT} Valid Delay	2	6	2	6	2	6	1
10	TdEXT(INT)	\overline{DCD} or \overline{CTS} Transition to \overline{INT} Valid Delay	2	6	2	6	2	6	1

- Notes :
1. Open-drain output, measured with open-drain test load.
 2. RxC is RTxC or TRxC, whichever is supplying the receive clock.
 3. TxC is TRxC or RTxC, whichever is supplying the transmit clock.
- * Timings are preliminary and subject to change.
† Units equal to TcPC.

PACKAGES MECHANICAL DATA

Figure 81: Z8530 40-Pin Dual in Line Plastic

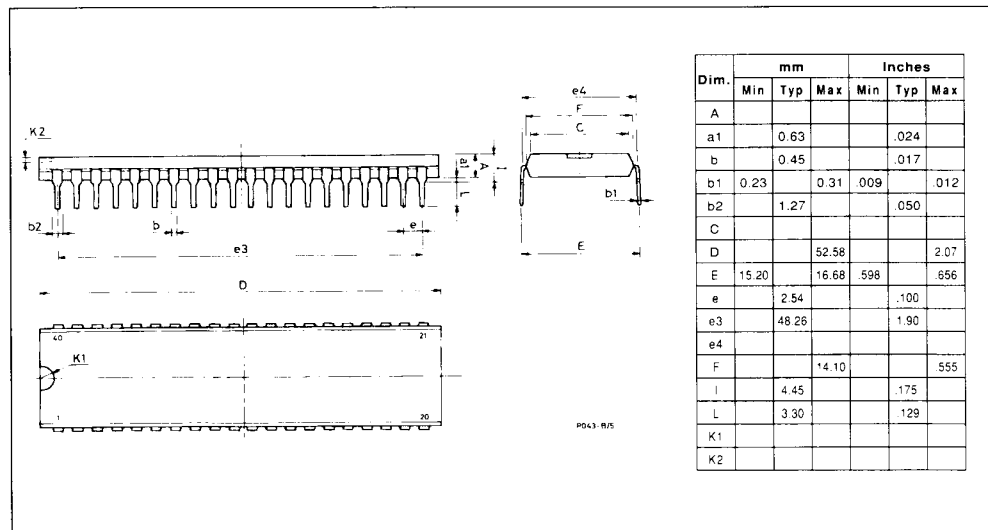

PACKAGE MECHANICAL DATA (cont'd)

Figure 82: Z8530 40-Pin Dual in Line Ceramic Multilayer.

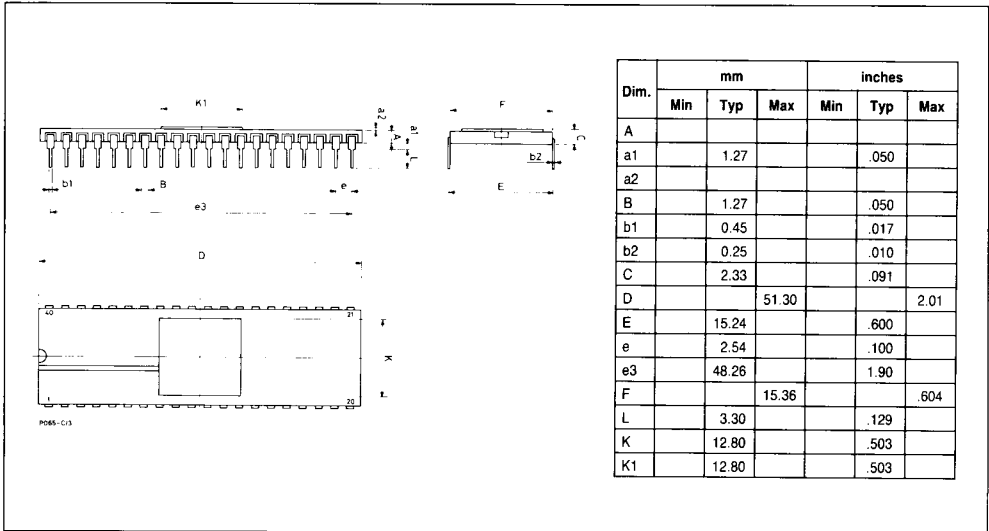
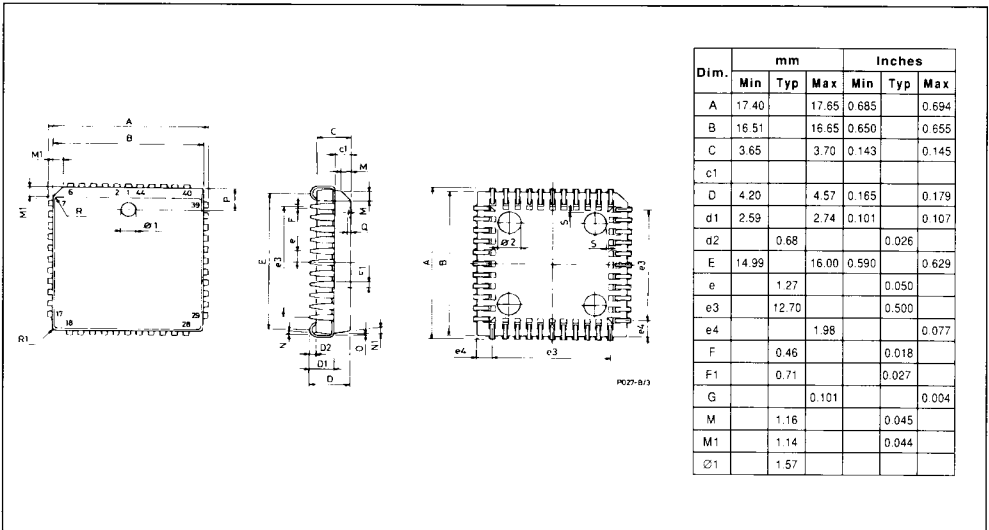

Figure 83 : Z8530 44-Lead Plastic Leaded Chip Carrier.



ORDERING INFORMATION

Sales Type	Frequency	Supply Voltage	Temp. Range	Package
Z8530B1V	4 MHz	5 V ± 5 %	0 to + 70 °C	PDIP-40
Z8530B6V	4 MHz	5 V ± 5 %	- 40 to + 85 °C	PDIP-40
Z8530D1N	4 MHz	5 V ± 5 %	0 to + 70 °C	CDIP-40
Z8530D6N	4 MHz	5 V ± 5 %	- 40 to + 85 °C	CDIP-40
Z8530D2N	4 MHz	5 V ± 5 %	- 55 to + 125 °C	CDIP-40
Z8530C1V	4 MHz	5 V ± 5 %	0 to + 70 °C	PLCC44
Z8530C6V	4 MHz	5 V ± 5 %	- 40 to + 85 °C	PLCC44
Z8530AB1V	6 MHz	5 V ± 5 %	0 to + 70 °C	PDIP-40
Z8530AB6V	6 MHz	5 V ± 5 %	- 40 to + 85 °C	PDIP-40
Z8530AD1N	6 MHz	5 V ± 5 %	0 to + 70 °C	CDIP-40
Z8530AD6N	6 MHz	5 V ± 5 %	- 40 to + 85 °C	CDIP-40
Z8530AD2N	6 MHz	5 V ± 5 %	- 55 to + 125 °C	CDIP-40
Z8530AC1V	6 MHz	5 V ± 5 %	0 to + 70 °C	PLCC44
Z8530AC6V	6 MHz	5 V ± 5 %	- 40 to + 85 °C	PLCC44
Z8530BB1V	8 MHz	5 V ± 5 %	0 to + 70 °C	PDIP-40
Z8530BB6V	8 MHz	5 V ± 5 %	- 40 to + 85 °C	PDIP-40
Z8530BD1N	8 MHz	5 V ± 5 %	0 to + 70 °C	CDIP-40
Z8530BD6N	8 MHz	5 V ± 5 %	- 40 to + 85 °C	CDIP-40
Z8530BC1V	8 MHz	5 V ± 5 %	0 to + 70 °C	PLCC44
Z8530BC6V	8 MHz	5 V ± 5 %	- 40 to + 85 °C	PLCC44

Note : PDIP = Plastic DIP ; CDIP = Ceramic Multilayer DIP ; PLCC = Plastic Leaded Chip Carrier.