



### 300W Zener Type Power Surge Suppressor

#### Features

- Glass passivated junction
- Zener type suppressor
- Superior clamping ability
- Metric and UNF thread type

#### Mechanical Characteristics

- Hermetically sealed DO-9 outline
- External surfaces corrosion resistant & terminal Solderable
- Weight: 16 grams
- Torque Setting: 3.5 Nm

#### Applications

- Voltage regulators
- Voltage surge suppressors
- Voltage clippers

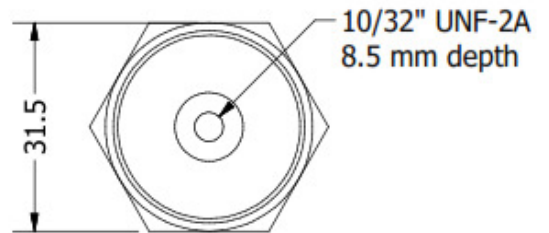

#### Ordering Table

300Z	34.5	-
1	2	3

##### 1 – Wattage

- > 300Z = 300W
- > 301Z = 300W

##### 2 – Voltage (See Voltage Ratings Table)

##### 3 – Tolerance

- > None = 20%
- > A = 10%
- > B = 5%

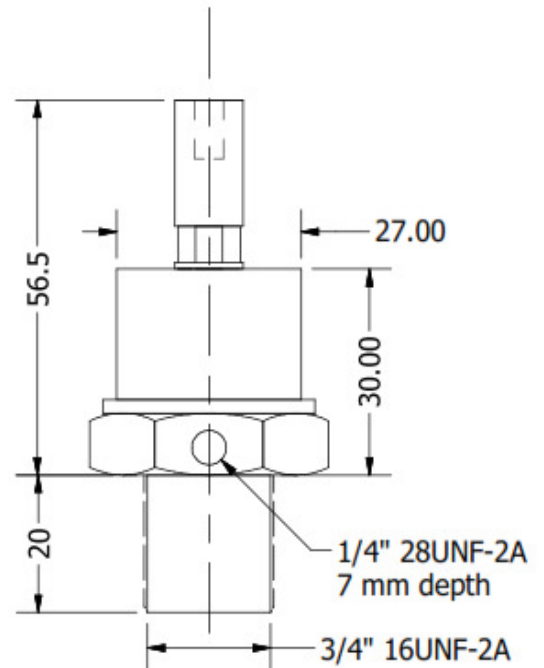

ALL DIMENSIONS IN MM



Electrical Specifications ( $T_C = 25^\circ\text{C}$ , unless otherwise noted)				
Symbol	Parameters	Conditions	300Z/301Z	Units
$P_Z$	Maximum Zener power rating	$T_C = 125^\circ\text{C}$	300	W
$V_Z$	Zener voltage range		34.5 – 150	V
$I_R$	Maximum leakage current	@ test voltage level	5.0	mA

Thermal & Mechanical Specifications ( $T_C = 25^\circ\text{C}$ , unless otherwise noted)			
Symbol	Parameters	300Z/301Z	Units
$T_j$	Max. operating junction temperature range	-40 to +175	$^\circ\text{C}$
$T_{stg}$	Max. storage temperature range	-40 to +175	$^\circ\text{C}$
$R_{thJC}$	Thermal resistance, junction to case	0.18	$^\circ\text{C}/\text{W}$
$R_{thCS}$	Thermal resistance, case to sink	0.08	$^\circ\text{C}/\text{W}$
F	Mounting torque	33 to 37	Nm
W	Approximate weight	178	g

Voltage Ratings ( $T_C = 25^\circ\text{C}$ , unless otherwise noted)						
Part numbers		$V_Z$ , Nominal Zener Voltage (V)	$V_{ZSM}$ , Max. Zener Voltage @ max. Zener Current ( $I_{ZSM}$ )		$V_R$ , Min. Reverse Voltage <sup>(2)</sup> (V)	Tolerance @ Test Current $I_{ZT} = 1.0 \text{ A}$ (%)
			$V_{ZSM}$ (V)	@ $I_{ZSM}$ <sup>(1)</sup> (A)		
300Z34.5	301Z34.5	34.5	54	550	23	20
300Z50	301Z50	50	78	380	35	20
300Z75	301Z75	75	117	250	52	20
300Z100	301Z100	100	156	190	69	20
300Z125	301Z125	125	195	150	87	20
300Z150	301Z150	150	234	120	104	20
300Z34.5A	301Z34.5A	34.5	49	610	27	10
300Z50A	301Z50A	50	72	410	39	10
300Z75A	301Z75A	75	107	280	58	10
300Z100A	301Z100A	100	143	210	78	10
300Z125A	301Z125A	125	179	160	98	10
300Z150A	301Z150A	150	215	140	117	10
300Z34.5B	301Z34.5B	34.5	47	630	28	5
300Z50B	301Z50B	50	68	440	41	5
300Z75B	301Z75B	75	102	290	61	5
300Z100B	301Z100B	100	137	210	82	5
300Z125B	301Z125B	125	171	170	103	5
300Z150B	301Z150B	150	205	140	123	5

(1)  $T_C = 25^\circ\text{C}$ ,  $T_p = 1 \text{ ms}$

(2)  $T_C = 25^\circ\text{C}$ ,  $I = \text{max. } I_R = 5.0 \text{ mA}$