

HX313C9FW/8

8GB 1G x 64-Bit DDR3-1333
CL9 240-Pin DIMM



SPECIFICATIONS

CL(IDD)	9 cycles
Row Cycle Time (tRCmin)	49.125ns (min.)
Refresh to Active/Refresh Command Time (tRFCmin)	260ns (min.)
Row Active Time (tRASmin)	36ns (min.)
Maximum Operating Power	TBD W*
UL Rating	94 V - 0
Operating Temperature	0° C to 85° C
Storage Temperature	-55° C to +100° C

*Power will vary depending on the SDRAM used.

DESCRIPTION

HyperX HX313C9FW/8 is a 1G x 64-bit (8GB) DDR3-1333 CL9 SDRAM (Synchronous DRAM) 2Rx8 memory module, based on sixteen 512M x 8-bit DDR3 FBGA components. This module has been tested to run at DDR3-1333 at latency timing 9-9-9 at 1.5V. The JEDEC standard electrical and mechanical specifications are as follows:

FEATURES

- JEDEC standard 1.5V (1.425V ~1.575V) Power Supply
- VDDQ = 1.5V (1.425V ~ 1.575V)
- 667MHz fCK for 1333Mb/sec/pin
- 8 independent internal bank
- Programmable CAS Latency: 9, 8, 7, 6
- Programmable Additive Latency: 0, CL - 2, or CL - 1 clock
- 8-bit pre-fetch
- Burst Length: 8 (Interleave without any limit, sequential with starting address "000" only), 4 with tCCD = 4 which does not allow seamless read or write [either on the fly using A12 or MRS]
- Bi-directional Differential Data Strobe
- Internal(self) calibration : Internal self calibration through ZQ pin (RZQ : 240 ohm ± 1%)
- On Die Termination using ODT pin
- Average Refresh Period 7.8us at lower than TCASE 85°C, 3.9us at 85°C < TCASE ≤ 95°C
- Asynchronous Reset
- Height 1.291" (32.80mm) w/heatsink, double sided component

Continued >>

MODULE WITH HEAT SPREADER

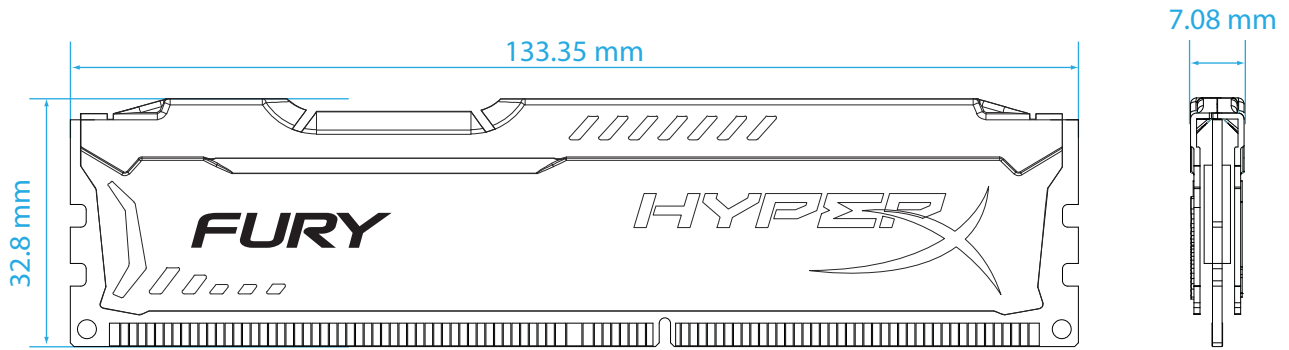

MODULE DIMENSIONS

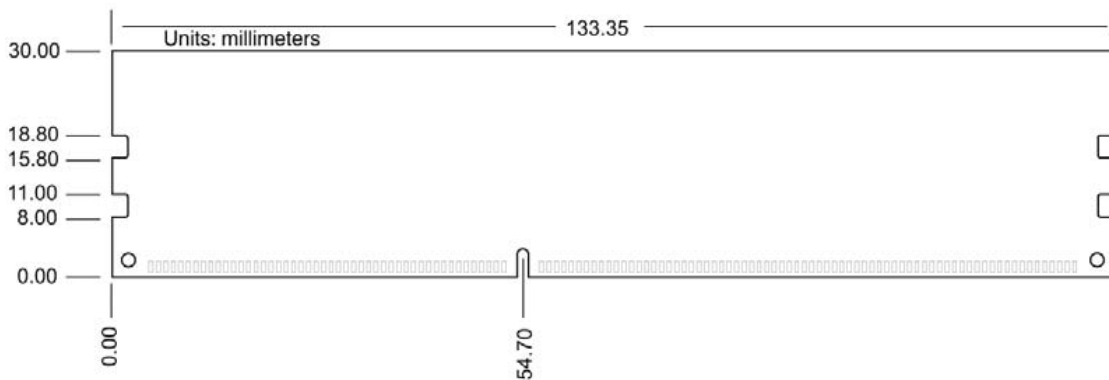
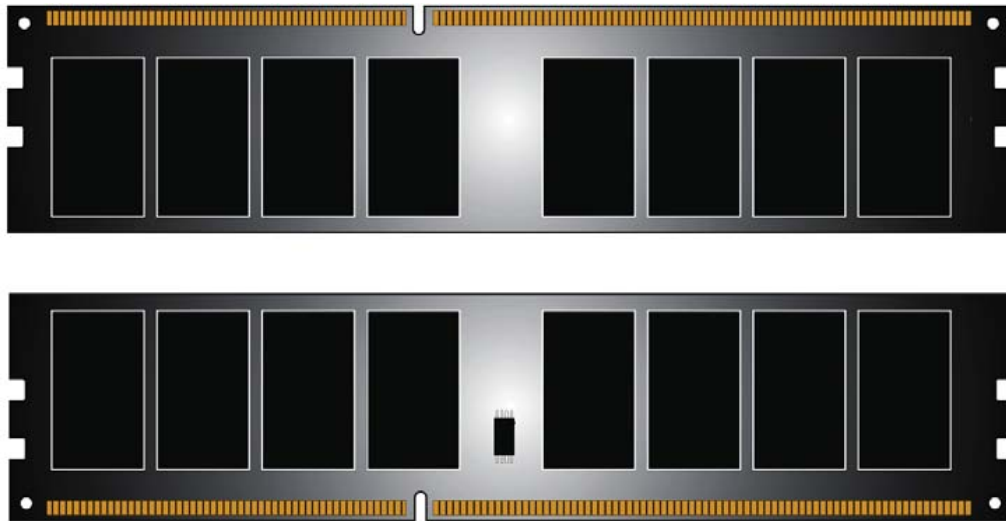

FOR MORE INFORMATION, GO TO WWW.KINGSTON.COM/HYPERX

All Kingston products are tested to meet our published specifications. Some motherboards or system configurations may not operate at the published HyperX memory speeds and timing settings. Kingston does not recommend that any user attempt to run their computers faster than the published speed. Overclocking or modifying your system timing may result in damage to computer components.