

ELM97xxxxB CMOS Voltage detector

■General description

ELM97xxxxB is CMOS voltage detector IC which consists of very-low-power-consumption reference voltage source, comparator, output driver, hysteresis circuit and detection voltage setting resistor. Because of positive logic output, the output becomes low level when Vdd is lower than detection voltage. There are 2 types of output style of ELM97 series: N-ch opendrain and CMOS output. ELM97 series can be made as semi-custom IC within the range of 0.9V to 5.5V(N-ch) and 1.6V to 5.5V(CMOS) by 0.1V step.

■Features

- Detection voltage range : N-ch 0.9V to 5.5V (by 0.1V)
CMOS 1.6V to 5.5V (by 0.1V)
- Low voltage operation : Reset operation assured at 0.8V
- Low current consumption : Typ.1 μ A(Vdd=1.5V)
- Accuracy of detection voltage : \pm 2.5%
- Temperature coefficient : Typ.-300ppm/ $^{\circ}$ C(Vdetn<2V)
Typ.-100ppm/ $^{\circ}$ C(Vdetn \geq 2V)
- Package : SOT-89, SOT-23

■Application

- Reset for microcomputers
- Power voltage shortage detectors
- Switch of backup power source
- Battery checkers

■Maximum absolute ratings

Parameter	Symbol	Limit	Unit
Power supply voltage	Vdd	10	V
Output voltage	Vout	N-ch : Vss-0.3 to +10	V
		CMOS : Vss-0.3 to Vdd+0.3	
Output current	Iout	50	mA
Power dissipation	Pd	500 (SOT-89)	mW
		250 (SOT-23)	
Operating temperature	Top	-40 to +85	$^{\circ}$ C
Storage temperature	Tstg	-55 to +125	$^{\circ}$ C

■Selection guide

ELM97xxxxB-x

Symbol		
a, b	Detection voltage	e.g. : 09: Vdetn=0.9V(N-ch) 24: Vdetn=2.4V(CMOS) 10: Vdetn=1.0V(N-ch) 30: Vdetn=3.0V(CMOS) 11: Vdetn=1.1V(N-ch) 45: Vdetn=4.5V(CMOS)
c	Output form	N: N-ch(N-ch opendrain) C: CMOS
d	Package	A: SOT-89 B: SOT-23
e	Product version	B
f	Taping direction	S: Refer to PKG file N: Refer to PKG file

ELM97 x x x x B - x
 \uparrow \uparrow \uparrow \uparrow \uparrow \uparrow
a b c d e f

ELM97xxxxB CMOS Voltage detector

■ Pin configuration

SOT-89(TOP VIEW)

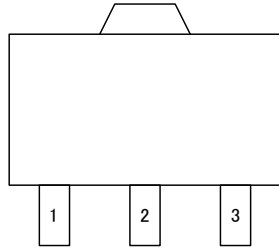

Pin No.	Pin name
1	OUT
2	VDD
3	VSS

SOT-23(TOP VIEW)

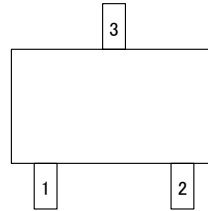

Pin No.	Pin name
1	OUT
2	VSS
3	VDD

■ Block diagram

N-ch Output

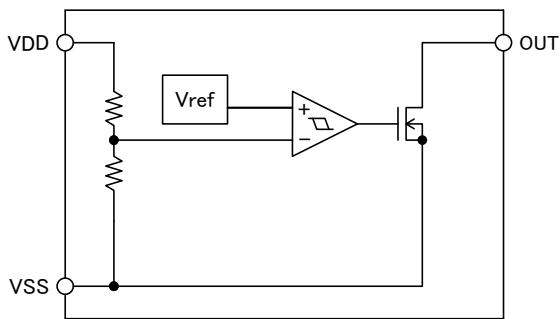

CMOS Output

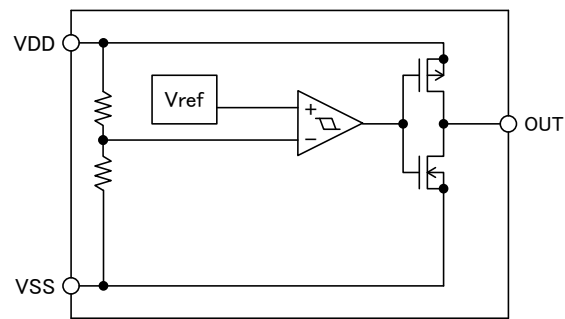

■ Timing chart

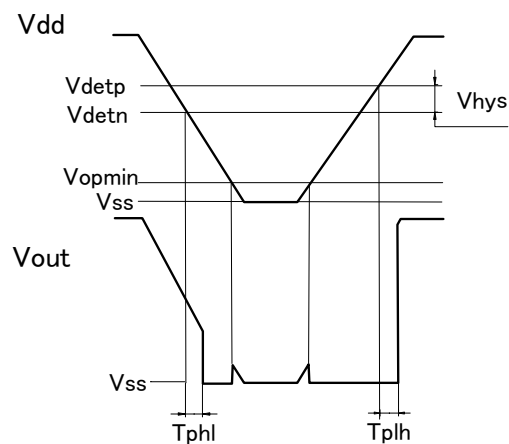

ELM97xxxxB CMOS Voltage detector

■Electrical characteristics (N-ch)

Vdetn=0.9V(ELM9709NxB)

Top=25°C

Parameter	Symbol	Condition	Min.	Typ.	Max.	Unit	Note
Detection voltage	Vdetn		0.878	0.900	0.922	V	2
Hysteresis width	Vhys		Vdetn ×0.02		Vdetn ×0.08	V	2
Current consumption	I _{ss}	V _{dd} =1.5V		1.0	3.0	μA	1
Power voltage	V _{dd}		0.8		6.0	V	2
Output current	I _{outn}	V _{dd} =0.8V, V _{ds} =0.5V	0.002	0.100		mA	3-(1)
Delay time	T _{phl}			2		ms	4
Temperature characteristic of Vdetn	$\frac{\Delta V_{detn}}{\Delta T_{op}}$	Top=-40°C to +85°C		-0.27		mV/°C	

Note: Test circuit No.

Vdetn=1.0V(ELM9710NxB)

Top=25°C

Parameter	Symbol	Condition	Min.	Typ.	Max.	Unit	Note
Detection voltage	Vdetn		0.975	1.000	1.025	V	2
Hysteresis width	Vhys		Vdetn ×0.02		Vdetn ×0.08	V	2
Current consumption	I _{ss}	V _{dd} =1.5V		1.0	3.0	μA	1
Power voltage	V _{dd}		0.8		6.0	V	2
Output current	I _{outn}	V _{dd} =0.8V, V _{ds} =0.5V	0.002	0.100		mA	3-(1)
Delay time	T _{phl}			2		ms	4
Temperature characteristic of Vdetn	$\frac{\Delta V_{detn}}{\Delta T_{op}}$	Top=-40°C to +85°C		-0.30		mV/°C	

Note: Test circuit No.

Vdetn=1.1V(ELM9711NxB)

Top=25°C

Parameter	Symbol	Condition	Min.	Typ.	Max.	Unit	Note
Detection voltage	Vdetn		1.073	1.100	1.127	V	2
Hysteresis width	Vhys		Vdetn× 0.02		Vdetn ×0.08	V	2
Current consumption	I _{ss}	V _{dd} =1.5V		1.0	3.0	μA	1
Power voltage	V _{dd}		0.8		6.0	V	2
Output current	I _{outn}	V _{dd} =0.8V, V _{ds} =0.5V	0.002	0.100		mA	3-(1)
Delay time	T _{phl}			2		ms	4
Temperature characteristic of Vdetn	$\frac{\Delta V_{detn}}{\Delta T_{op}}$	Top=-40°C to +85°C		-0.33		mV/°C	

Note: Test circuit No.

ELM97xxxxB CMOS Voltage detector

■Electrical characteristics (CMOS)

Vdetn=2.2V(ELM9722Cx B)

Top=25°C

Parameter	Symbol	Condition	Min.	Typ.	Max.	Unit	Note
Detection voltage	Vdetn		2.145	2.200	2.255	V	2
Hysteresis width	Vhys		Vdetn ×0.02		Vdetn ×0.08	V	2
Current consumption	I _{ss}	V _{dd} =3.0V		1.5	4.5	μA	1
Power voltage	V _{dd}		0.8		6.0	V	2
Output current	I _{outn}	V _{dd} =1.5V, V _{ds} =0.5V	1.0	2.0		mA	3-(1)
	I _{outp}	V _{dd} =4.5V, V _{ds} =2.1V	0.5	1.5			3-(2)
Delay time	T _{phl}			0.1		ms	4
Temperature characteristic of Vdetn	$\frac{\Delta V_{detn}}{\Delta T_{op}}$	Top=-40°C to +85°C		-0.22		mV/°C	

Note: Test circuit No.

Vdetn=2.4V(ELM9724Cx B)

Top=25°C

Parameter	Symbol	Condition	Min.	Typ.	Max.	Unit	Note
Detection voltage	Vdetn		2.340	2.400	2.460	V	2
Hysteresis width	Vhys		Vdetn ×0.02		Vdetn ×0.08	V	2
Current consumption	I _{ss}	V _{dd} =3.0V		1.5	4.5	μA	1
Power voltage	V _{dd}		0.8		6.0	V	2
Output current	I _{outn}	V _{dd} =1.5V, V _{ds} =0.5V	1.0	2.0		mA	3-(1)
	I _{outp}	V _{dd} =4.5V, V _{ds} =2.1V	0.5	1.5			3-(2)
Delay time	T _{phl}			0.1		ms	4
Temperature characteristic of Vdetn	$\frac{\Delta V_{detn}}{\Delta T_{op}}$	Top=-40°C to +85°C		-0.24		mV/°C	

Note: Test circuit No.

Vdetn=2.5V(ELM9725Cx B)

Top=25°C

Parameter	Symbol	Condition	Min.	Typ.	Max.	Unit	Note
Detection voltage	Vdetn		2.438	2.500	2.562	V	2
Hysteresis width	Vhys		Vdetn ×0.02		Vdetn ×0.08	V	2
Current consumption	I _{ss}	V _{dd} =3.0V		1.5	4.5	μA	1
Power voltage	V _{dd}		0.8		6.0	V	2
Output current	I _{outn}	V _{dd} =1.5V, V _{ds} =0.5V	1.0	2.0		mA	3-(1)
	I _{outp}	V _{dd} =4.5V, V _{ds} =2.1V	0.5	1.5			3-(2)
Delay time	T _{phl}			0.1		ms	4
Temperature characteristic of Vdetn	$\frac{\Delta V_{detn}}{\Delta T_{op}}$	Top=-40°C to +85°C		-0.25		mV/°C	

Note: Test circuit No.

ELM97xxxxB CMOS Voltage detector

Vdetn=2.7V(ELM9727CxB)

Top=25°C

Parameter	Symbol	Condition	Min.	Typ.	Max.	Unit	Note
Detection voltage	Vdetn		2.633	2.700	2.767	V	2
Hysteresis width	Vhys		Vdetn ×0.02		Vdetn ×0.08	V	2
Current consumption	I _{ss}	V _{dd} =4.5V		1.5	4.5	μA	1
Power voltage	V _{dd}		0.8		6.0	V	2
Output current	I _{outn}	V _{dd} =1.5V, V _{ds} =0.5V	1.0	2.0		mA	3-(1)
	I _{outp}	V _{dd} =4.5V, V _{ds} =2.1V	0.5	1.5			3-(2)
Delay time	T _{phl}			0.1		ms	4
Temperature characteristic of Vdetn	$\frac{\Delta V_{detn}}{\Delta T_{op}}$	Top=-40°C to +85°C		-0.27		mV/°C	

Note: Test circuit No.

Vdetn=3.0V(ELM9730CxB)

Top=25°C

Parameter	Symbol	Condition	Min.	Typ.	Max.	Unit	Note
Detection voltage	Vdetn		2.925	3.000	3.075	V	2
Hysteresis width	Vhys		Vdetn ×0.02		Vdetn ×0.08	V	2
Current consumption	I _{ss}	V _{dd} =4.5V		1.5	4.5	μA	1
Power voltage	V _{dd}		0.8		6.0	V	2
Output current	I _{outn}	V _{dd} =1.5V, V _{ds} =0.5V	1.0	2.0		mA	3-(1)
	I _{outp}	V _{dd} =4.5V, V _{ds} =2.1V	0.5	1.5			3-(2)
Delay time	T _{phl}			0.1		ms	4
Temperature characteristic of Vdetn	$\frac{\Delta V_{detn}}{\Delta T_{op}}$	Top=-40°C to +85°C		-0.30		mV/°C	

Note: Test circuit No.

Vdetn=3.2V(ELM9732CxB)

Top=25°C

Parameter	Symbol	Condition	Min.	Typ.	Max.	Unit	Note
Detection voltage	Vdetn		3.120	3.200	3.280	V	2
Hysteresis width	Vhys		Vdetn ×0.02		Vdetn ×0.08	V	2
Current consumption	I _{ss}	V _{dd} =4.5V		1.5	4.5	μA	1
Power voltage	V _{dd}		0.8		6.0	V	2
Output current	I _{outn}	V _{dd} =1.5V, V _{ds} =0.5V	1.0	2.0		mA	3-(1)
	I _{outp}	V _{dd} =4.5V, V _{ds} =2.1V	0.5	1.5			3-(2)
Delay time	T _{phl}			0.1		ms	4
Temperature characteristic of Vdetn	$\frac{\Delta V_{detn}}{\Delta T_{op}}$	Top=-40°C to +85°C		-0.32		mV/°C	

Note: Test circuit No.

ELM97xxxxB CMOS Voltage detector

Vdetn=3.4V(ELM9734CxB)

Top=25°C

Parameter	Symbol	Condition	Min.	Typ.	Max.	Unit	Note
Detection voltage	Vdetn		3.315	3.400	3.485	V	2
Hysteresis width	Vhys		Vdetn ×0.02		Vdetn ×0.08	V	2
Current consumption	I _{ss}	V _{dd} =4.5V		1.5	4.5	μA	1
Power voltage	V _{dd}		0.8		6.0	V	2
Output current	I _{outn}	V _{dd} =1.5V, V _{ds} =0.5V	1.0	2.0		mA	3-(1)
	I _{outp}	V _{dd} =4.5V, V _{ds} =2.1V	0.5	1.5			3-(2)
Delay time	T _{phl}			0.1		ms	4
Temperature characteristic of Vdetn	$\frac{\Delta V_{detn}}{\Delta T_{op}}$	Top=-40°C to +85°C		-0.34		mV/°C	

Note: Test circuit No.

Vdetn=4.5V(ELM9745CxB)

Top=25°C

Parameter	Symbol	Condition	Min.	Typ.	Max.	Unit	Note
Detection voltage	Vdetn		4.388	4.500	4.612	V	2
Hysteresis width	Vhys		Vdetn ×0.02		Vdetn ×0.08	V	2
Current consumption	I _{ss}	V _{dd} =6.0V		1.5	4.5	μA	1
Power voltage	V _{dd}		0.8		6.0	V	2
Output current	I _{outn}	V _{dd} =1.5V, V _{ds} =0.5V	1.0	2.0		mA	3-(1)
	I _{outp}	V _{dd} =6.0V, V _{ds} =2.1V	0.5	2.0			3-(2)
Delay time	T _{phl}			0.1		ms	4
Temperature characteristic of Vdetn	$\frac{\Delta V_{detn}}{\Delta T_{op}}$	Top=-40°C to +85°C		-0.45		mV/°C	

Note: Test circuit No.

Vdetn=4.8V(ELM9748CxB)

Top=25°C

Parameter	Symbol	Condition	Min.	Typ.	Max.	Unit	Note
Detection voltage	Vdetn		4.680	4.800	4.920	V	2
Hysteresis width	Vhys		Vdetn ×0.02		Vdetn ×0.08	V	2
Current consumption	I _{ss}	V _{dd} =6.0V		1.5	4.5	μA	1
Power voltage	V _{dd}		0.8		6.0	V	2
Output current	I _{outn}	V _{dd} =1.5V, V _{ds} =0.5V	1.0	2.0		mA	3-(1)
	I _{outp}	V _{dd} =6.0V, V _{ds} =2.1V	0.5	2.0			3-(2)
Delay time	T _{phl}			0.1		ms	4
Temperature characteristic of Vdetn	$\frac{\Delta V_{detn}}{\Delta T_{op}}$	Top=-40°C to +85°C		-0.48		mV/°C	

Note: Test circuit No.

ELM97xxxxB CMOS Voltage detector

■ Test circuits

1) Current consumption

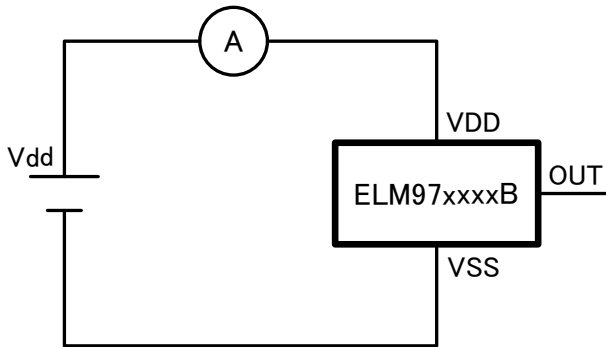

2) Detection voltage

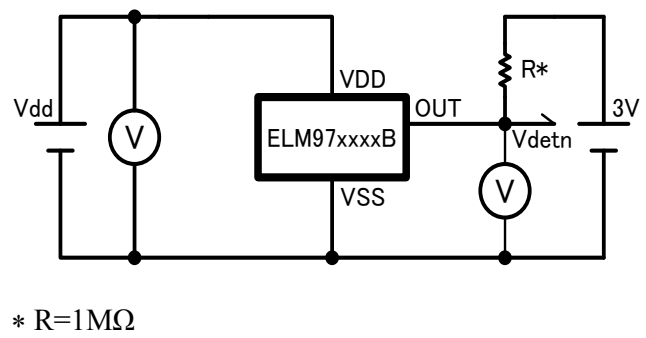

3)-(1) Output current (N-ch)

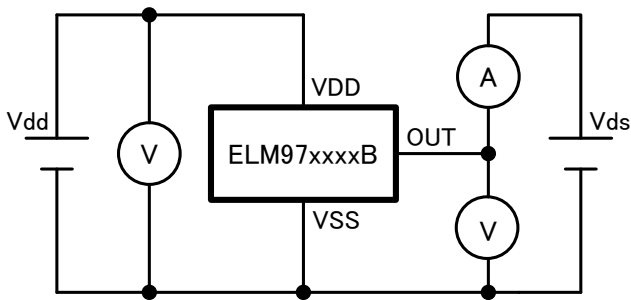

3)-(2) Output current (P-ch)

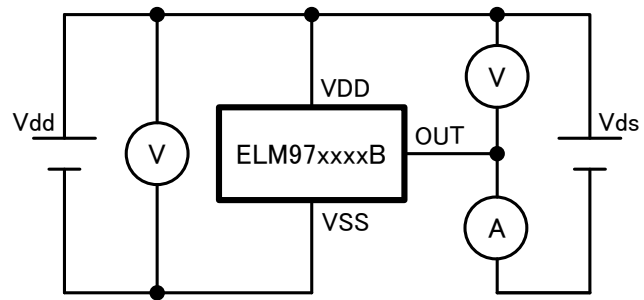

4) Delay time

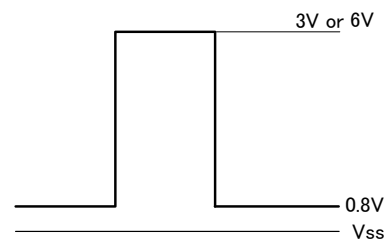
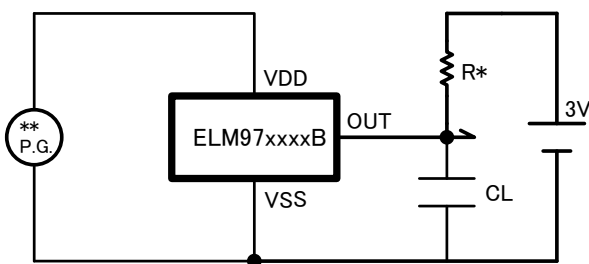

* R=1MΩ

R is unnecessary for CMOS output products.

** Input pulse

ELM97xxxxB CMOS Voltage detector

■ Marking

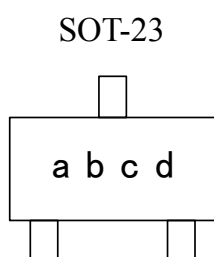
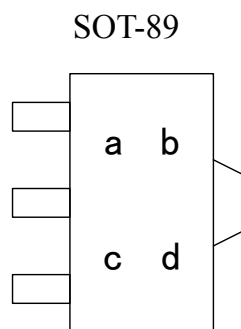

• Rule 1

a : the integer digit of the detection voltage

Mark	Vdetn	Mark	Vdetn
A	0.*V (N-ch)	P	2.*V (CMOS)
B	1.*V (N-ch)	R	3.*V (CMOS)
C	2.*V (N-ch)	S	4.*V (CMOS)
D	3.*V (N-ch)	T	5.*V (CMOS)
E	4.*V (N-ch)	U	1.*V (CMOS)
F	5.*V (N-ch)		

b : the decimal digit of the detection voltage

Mark	Vdetn	Mark	Vdetn
0	*.0V	5	*.5V
1	*.1V	6	*.6V
2	*.2V	7	*.7V
3	*.3V	8	*.8V
4	*.4V	9	*.9V

c : Assembly lot No. ——— A to Z (I, O, X excepted)

d : Assembly lot No. ——— 0 to 9

• Rule 2

a : A (ELM97 series mark)

b : the integer digit of the detection voltage

Mark	Vdetn	Mark	Vdetn
0	0.*V (N-ch)	Y	2.*V (CMOS)
1	1.*V (N-ch)	W	3.*V (CMOS)
2	2.*V (N-ch)	U	4.*V (CMOS)
3	3.*V (N-ch)	V	5.*V (CMOS)
4	4.*V (N-ch)	Z	1.*V (CMOS)
5	5.*V (N-ch)		

c : the decimal digit of the detection voltage

Mark	Vdetn	Mark	Vdetn
0	*.0V	5	*.5V
1	*.1V	6	*.6V
2	*.2V	7	*.7V
3	*.3V	8	*.8V
4	*.4V	9	*.9V

d : Assembly lot No. ——— 0 to 9 and A to Z (I, O, X excepted)

Remarks : ELM97 series have two kinds of marking rules each package.

ELM97xxxxB CMOS Voltage detector

■ Typical characteristics

- $V_{detn}=1.1V$, N-ch(ELM9711Nx8)

