



SGM84782

4Ω, High Speed, Low Voltage Analog Switch/Multiplexer

GENERAL DESCRIPTION

The SGM84782 is high-speed, low-voltage, low on-resistance, CMOS analog multiplexer/switch that configured as two 4-channel multiplexers. It operates from a single +1.8V to +4.2V power supply. Targeted applications include battery powered equipment that benefit from low R_{ON} (4Ω) and fast switching speeds ($t_{ON} = 17ns$, $t_{OFF} = 9ns$).

The SGM84782 can handle rail-to-rail analog signals and is available in Green TQFN-3×3-16L and TSSOP-16 packages.

APPLICATIONS

- Communication Systems
- Cell Phones
- Portable Instrumentation
- Audio Signal Routing
- Audio and Video Switching
- Computer Peripherals
- Low-Voltage Data-Acquisition Systems

FUNCTION TABLE

CONTROL INPUTS		ON SWITCHES
ENABLE	Select B A	
L	L L	X-X0 Y-Y0
L	L H	X-X1 Y-Y1
L	H L	X-X2 Y-Y2
L	H H	X-X3 Y-Y3
H	√ √	All Switches Open

√ = Don't Care.

FEATURES

- Voltage Operation: 1.8V to 4.2V
- Low On-Resistance: 4Ω (TYP) at 4.2V
- Low On-Resistance Flatness
- -3dB Bandwidth: 150MHz
- Fast Switching Times (+4.2V)
 - t_{ON} 17ns
 - t_{OFF} 9ns
- Low Crosstalk: -92dB at 10MHz
- Rail-to-Rail Input and Output Operation
- Typical Power Consumption (< 0.01μW)
- TTL/CMOS Compatible
- Break-Before-Make Switching
- Extended Industrial Temperature Range:
 - 40°C to +85°C
- Available in Green TQFN-3×3-16L and TSSOP-16 Packages

PIN CONFIGURATIONS (TOP VIEW)

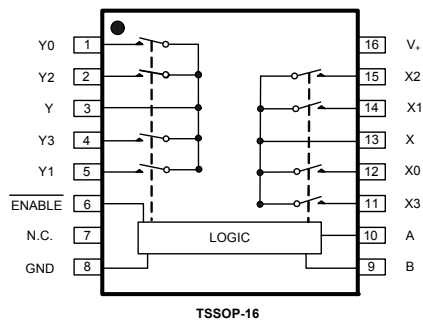
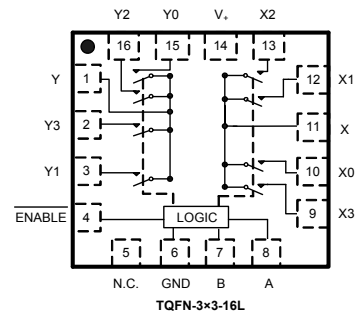

PACKAGE/ORDERING INFORMATION

MODEL	PIN-PACKAGE	SPECIFIED TEMPERATURE RANGE	ORDERING NUMBER	PACKAGE MARKING	PACKAGE OPTION
SGM84782	TQFN-3×3-16L	-40°C to +85°C	SGM84782YTQ16/TR	84782	Tape and Reel, 3000
	TSSOP-16	-40°C to +85°C	SGM84782YTS/TR	SGM84782YTS	Tape and Reel, 3000

ABSOLUTE MAXIMUM RATINGS

V ₊ to GND.....	0V to 4.6V
Analog, Digital voltage range.....	-0.3V to (V ₊) + 0.3V
Continuous Current NO, NC, or COM	±100mA
Operating Temperature Range.....	-40°C to +85°C
Junction Temperature.....	150°C
Storage Temperature Range.....	-65°C to +150°C
Lead Temperature (soldering, 10s).....	260°C
ESD Susceptibility	
HBM.....	4000V
MM.....	400V

NOTE: Stresses beyond those listed under “Absolute Maximum Ratings” may cause permanent damage to the device. These are stress ratings only, and functional operation of the device at these or any other conditions beyond those indicated in the operational sections of the specifications is not implied. Exposure to absolute maximum rating conditions for extended periods may affect device reliability.

CAUTION

This integrated circuit can be damaged by ESD if you don't pay attention to ESD protection. SGMICRO recommends that all integrated circuits be handled with appropriate precautions. Failure to observe proper handling and installation procedures can cause damage. ESD damage can range from subtle performance degradation to complete device failure. Precision integrated circuits may be more susceptible to damage because very small parametric changes could cause the device not to meet its published specifications.

SGMICRO reserves the right to make any change in circuit design, specification or other related things if necessary without notice at any time. Please contact SGMICRO sales office to get the latest datasheet.

PIN DESCRIPTION

PIN		NAME	FUNCTION
TSSOP-16	TQFN-3×3-16L		
1, 5, 2, 4	15, 3, 16, 2	Y0-Y3	Analog Switch Y Inputs Y0-Y3.
3	1	Y	Analog Switch Y Output.
6	4	$\overline{\text{ENABLE}}$	Digital Enable Input. Normally connect to GND. Drive to logic high to set all switches off.
7	5	N.C.	Not Internally Connected.
8	6	GND	Ground.
9	7	B	Digital Address B Input.
10	8	A	Digital Address A Input.
12, 14, 15, 11	10, 12, 13, 9	X0-X3	Analog Switch X Inputs X0-X3.
13	11	X	Analog Switch X Output.
16	14	V ₊	Power Supply.
—	Exposed Pad	GND	Exposed pad should be soldered to PCB board and connected to GND.

ELECTRICAL CHARACTERISTICS

(V₊ = +4.2V, GND = 0V, V_{IH} = +1.6V, V_{IL} = +0.6V, T_A = -40°C to +85°C. Typical values are at V₊ = +4.2V, T_A = +25°C, unless otherwise noted.)

PARAMETER	SYMBOL	CONDITIONS	TEMP	MIN	TYP	MAX	UNITS
ANALOG SWITCH							
Analog Signal Range	V _{X-} , V _{Y-} , V _X , V _Y		-40°C to +85°C	0		V ₊	V
On-Resistance	R _{ON}	V ₊ = 4.2V, I _{X-} , I _{Y-} = -100mA, V _X , V _Y = 1V, Test Circuit 1	+25°C		4	5.5	Ω
			-40°C to +85°C			6.5	
On-Resistance Match Between Channels	ΔR _{ON}	V ₊ = 4.2V, I _{X-} , I _{Y-} = -100mA, V _X , V _Y = 1V, Test Circuit 1	+25°C		0.16	1	Ω
			-40°C to +85°C			1.5	
On-Resistance Flatness	R _{FLAT(ON)}	V ₊ = 4.2V, I _{X-} , I _{Y-} = -100mA, V _X , V _Y = 1V, 2.5V, Test Circuit 1	+25°C		1.6	2.2	Ω
			-40°C to +85°C			2.8	
Source OFF Leakage Current	I _{X-(OFF)} , I _{Y-(OFF)}	V ₊ = 4.2V, V _{X-} , V _{Y-} = 3.3V, 0.3V, V _X , V _Y = 0.3V, 3.3V	-40°C to +85°C			1	μA
Channel ON Leakage Current	I _{X-(ON)} , I _{Y-(ON)} , I _{X(ON)} , I _{Y(ON)}	V ₊ = 4.2V, V _X , V _Y = 0.3V, 3.3V, V _{X-} , V _{Y-} = 0.3V, 3.3V or floating	-40°C to +85°C			1	μA
DIGITAL INPUTS							
Input High Voltage	V _{INH}		-40°C to +85°C	1.6			V
Input Low Voltage	V _{INL}		-40°C to +85°C			0.5	V
Input Leakage Current	I _{IN-}	V _A , V _B = V _{ENABLE} = 0V or 4.2V	-40°C to +85°C			1	μA
DYNAMIC CHARACTERISTICS							
Turn-On Time	t _{ON}	V _{IN} = 1.5V to 0.5V, V _X or V _Y = 2.1V R _L = 50Ω, C _L = 35pF, Test Circuit 2	+25°C		17.0		ns
Turn-Off Time	t _{OFF}		+25°C		9.0		
Address Transition Time	t _{TRANS}	V _{IN} = 4.2V to 0V, V _X or V _Y = 2.1V, R _L = 50Ω, C _L = 35pF, Test Circuit 3	+25°C		17.2		ns
Break-Before-Make Time Delay	t _D	V _{IN} = 4.2V to 0V, V _X or V _Y = 2.1V, R _L = 50Ω, C _L = 35pF, Test Circuit 4	+25°C		14.0		ns
Charge Injection	Q	C _L = 1nF, Test Circuit 5	+25°C		-18		pC
Off Isolation	O _{ISO}	Signal = 0dBm, V _{BIAS} = 2.1V, R _L = 50Ω, C _L = 35pF, Test Circuit 6	1MHz	+25°C		-60	dB
			10MHz	+25°C		-40	
Channel-to-Channel Crosstalk	X _{TALK}	Signal = 0dBm, V _{BIAS} = 2.1V, R _L = 50Ω, C _L = 35pF, Test Circuit 6	1MHz	+25°C		-105	dB
			10MHz	+25°C		-92	
-3dB Bandwidth	BW	Signal = 0dBm, V _{BIAS} = 2.1V, R _L = 50Ω, Test Circuit 6	+25°C		150		MHz
Channel ON Capacitance	C _{X-(ON)} , C _{Y-(ON)} , C _{X(ON)} , C _{Y(ON)}		+25°C		51.6		pF
POWER REQUIREMENTS							
Power Supply Range	V ₊		-40°C to +85°C	1.8		4.2	V
Power Supply Current	I ₊	V ₊ = 4.2V, V _A , V _B , V _{ENABLE} = 4.2V or 0V	-40°C to +85°C			1	μA

ELECTRICAL CHARACTERISTICS

(V_+ = +2.7V to +3.6V, GND = 0V, V_{IH} = +1.6V, V_{IL} = +0.4V, T_A = -40°C to +85°C. Typical values are at V_+ = +3.0V, T_A = +25°C, unless otherwise noted.)

PARAMETER	SYMBOL	CONDITIONS	TEMP	MIN	TYP	MAX	UNITS
ANALOG SWITCH							
Analog Signal Range	$V_{X-}, V_{Y-},$ V_{X+}, V_{Y+}		-40°C to +85°C	0		V_+	V
On-Resistance	R_{ON}	V_+ = 2.7V, I_{X-}, I_{Y-} = -100mA, V_{X+}, V_{Y+} = 1V, Test Circuit 1	+25°C		5	6	Ω
			-40°C to +85°C			7	
On-Resistance Match Between Channels	ΔR_{ON}	V_+ = 2.7V, I_{X-}, I_{Y-} = -100mA, V_{X+}, V_{Y+} = 1V, Test Circuit 1	+25°C		0.03	1	Ω
			-40°C to +85°C			1.5	
On-Resistance Flatness	$R_{FLAT(ON)}$	V_+ = 2.7V, I_{X-}, I_{Y-} = -100mA, V_{X+}, V_{Y+} = 1V, 2.5V, Test Circuit 1	+25°C		1.8	2.2	Ω
			-40°C to +85°C			2.8	
Source OFF Leakage Current	$I_{X-(OFF)},$ $I_{Y-(OFF)}$	V_+ = 3.6V, V_{X-}, V_{Y-} = 3.3V, 0.3V, V_{X+}, V_{Y+} = 0.3V, 3.3V	-40°C to +85°C			1	μA
Channel ON Leakage Current	$I_{X-(ON)}, I_{Y-(ON)},$ $I_{X+(ON)}, I_{Y+(ON)}$	V_+ = 3.6V, V_{X+}, V_{Y+} = 0.3V, 3.3V, V_{X-}, V_{Y-} = 0.3V, 3.3V or floating	-40°C to +85°C			1	μA
DIGITAL INPUTS							
Input High Voltage	V_{INH}		-40°C to +85°C	1.5			V
Input Low Voltage	V_{INL}		-40°C to +85°C			0.4	V
Input Leakage Current	I_{IN-}	$V_A, V_B = V_{ENABLE} = 0V$ or 2.7V	-40°C to +85°C			1	μA
DYNAMIC CHARACTERISTICS							
Turn-On Time	t_{ON}	$V_{IN} = 1.5V$ to 0.5V, V_X or $V_Y = 1.5V,$ $R_L = 50\Omega, C_L = 35pF,$ Test Circuit 2	+25°C		33.0		ns
Turn-Off Time	t_{OFF}		+25°C		9.0		
Address Transition Time	t_{TRANS}	$V_{IN} = 1.5V$ to 0V, V_X or $V_Y = 1.5V,$ $R_L = 50\Omega, C_L = 35pF,$ Test Circuit 3	+25°C		17.5		ns
Break-Before-Make Time Delay	t_D	$V_{IN} = 1.5V$ to 0V, V_X or $V_Y = 1.5V,$ $R_L = 50\Omega, C_L = 35pF,$ Test Circuit 4	+25°C		14.5		ns
Charge Injection	Q	$C_L = 1nF,$ Test Circuit 5	+25°C		-18		pC
Off Isolation	O_{ISO}	Signal = 0dBm, $V_{BIAS} = 1.5V,$ $R_L = 50\Omega, C_L = 35pF,$ Test Circuit 6	1MHz	+25°C		-60	dB
			10MHz	+25°C		-40	
Channel-to-Channel Crosstalk	X_{TALK}	Signal = 0dBm, $V_{BIAS} = 1.5V,$ $R_L = 50\Omega, C_L = 35pF,$ Test Circuit 6	1MHz	+25°C		-105	dB
			10MHz	+25°C		-92	
-3dB Bandwidth	BW	Signal = 0dBm, $V_{BIAS} = 1.5V,$ $R_L = 50\Omega,$ Test Circuit 6	+25°C		150		MHz
Channel ON Capacitance	$C_{X-(ON)}, C_{Y-(ON)},$ $C_{X+(ON)}, C_{Y+(ON)}$		+25°C		51.6		pF

TYPICAL PERFORMANCE CHARACTERISTICS

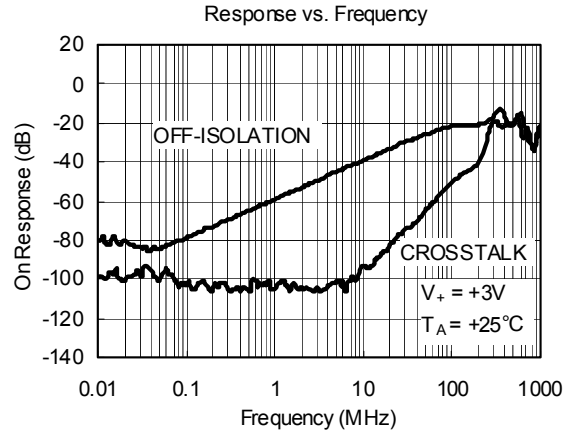
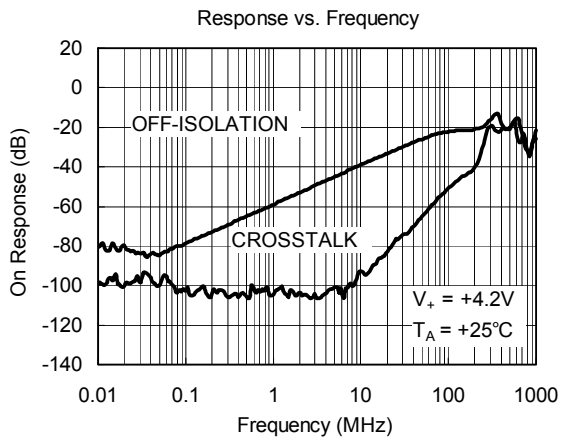
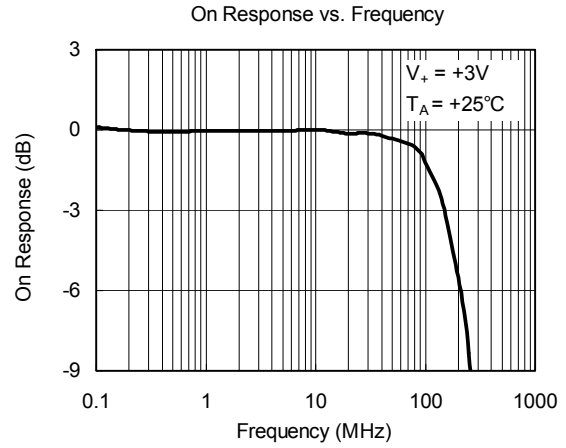
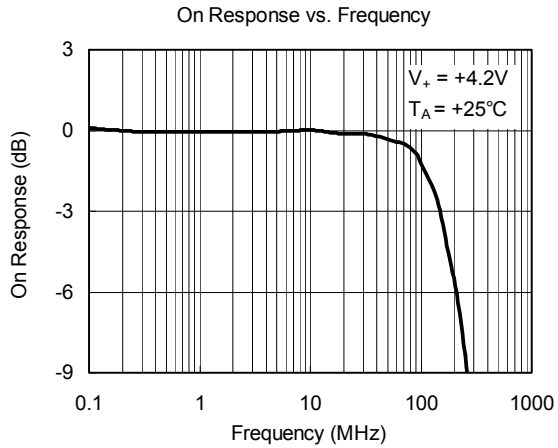

TEST CIRCUITS

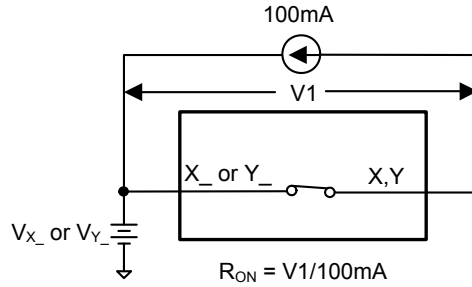

Test Circuit 1. On Resistance

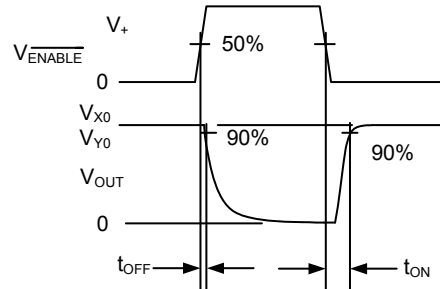
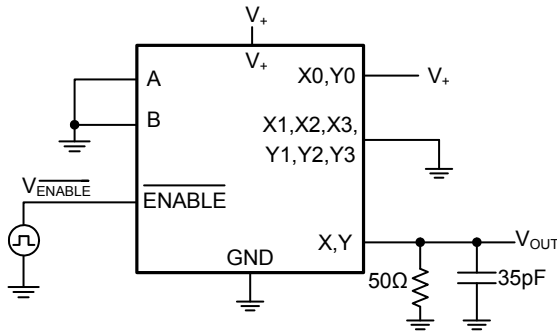

Test Circuit 2. Enable Switching Times (t_{ON} , t_{OFF})

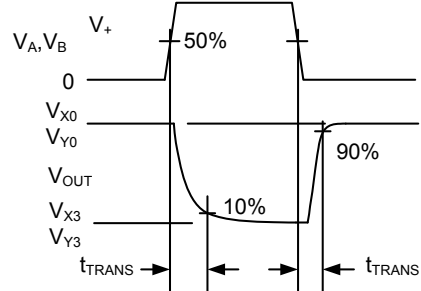
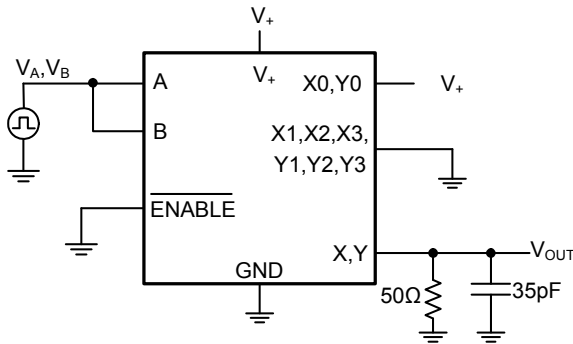

Test Circuit 3. Address Transition Times (t_{TRANS})

TEST CIRCUITS (Cont.)

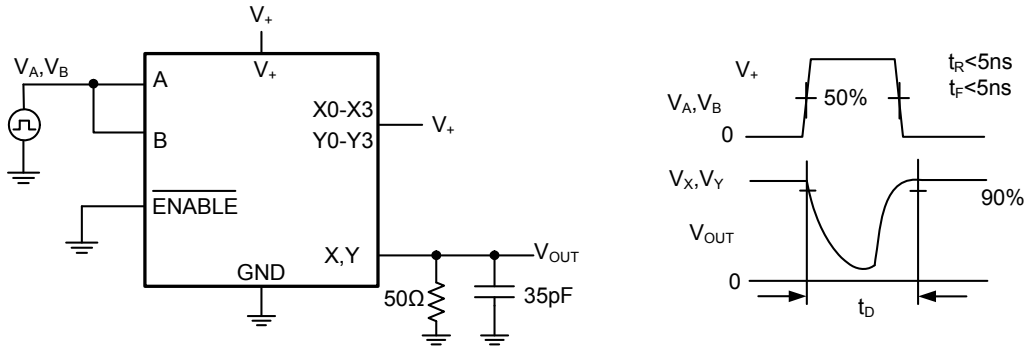

Test Circuit 4. Break-Before-Make Interval (t_b)

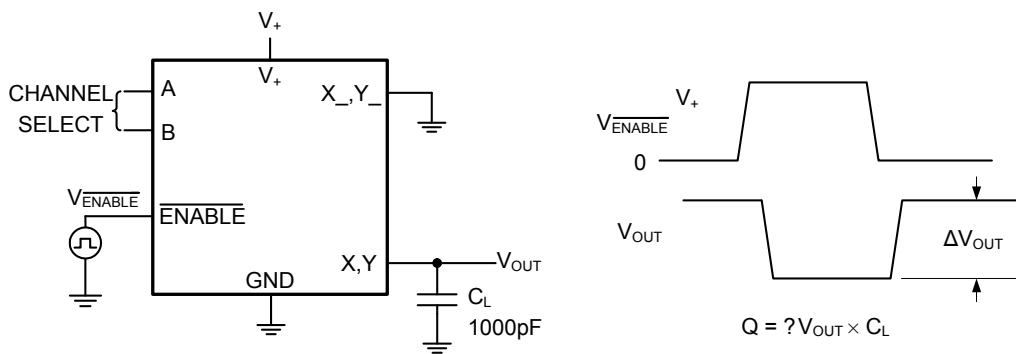

Test Circuit 5. Charge Injection (Q)

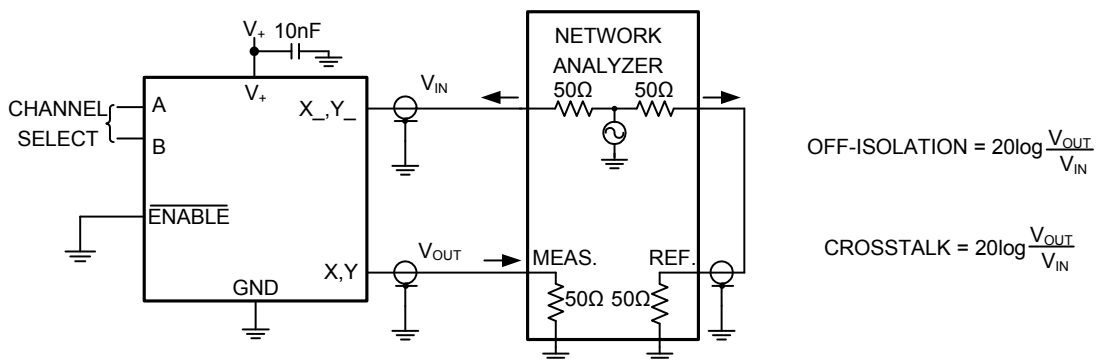

Test Circuit 6. -3dB Bandwidth, Off-Isolation and Crosstalk

PACKAGE OUTLINE DIMENSIONS

TQFN-3×3-16L

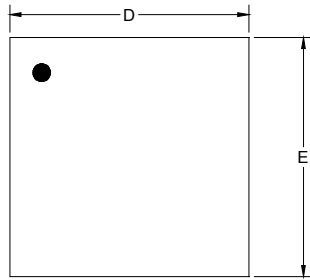

TOP VIEW

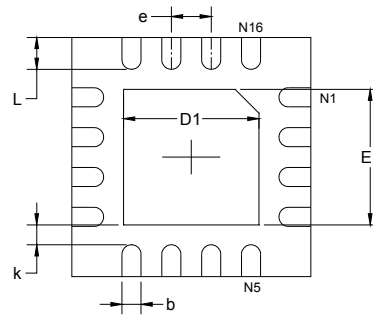

BOTTOM VIEW

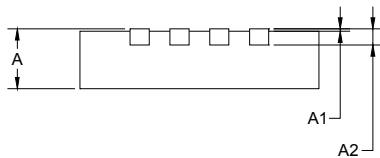

SIDE VIEW

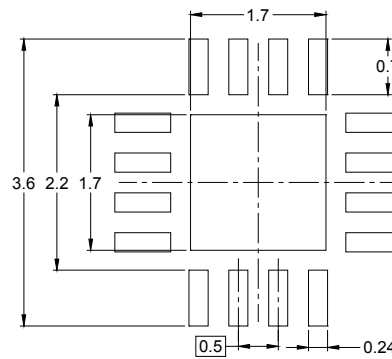

RECOMMENDED LAND PATTERN (Unit: mm)

Symbol	Dimensions In Millimeters		Dimensions In Inches	
	MIN	MAX	MIN	MAX
A	0.700	0.800	0.028	0.031
A1	0.000	0.050	0.000	0.002
A2	0.203 REF		0.008 REF	
D	2.900	3.100	0.114	0.122
D1	1.600	1.800	0.063	0.071
E	2.900	3.100	0.114	0.122
E1	1.600	1.800	0.063	0.071
k	0.200 MIN		0.008 MIN	
b	0.180	0.300	0.007	0.012
e	0.500 TYP		0.020 TYP	
L	0.300	0.500	0.012	0.020

PACKAGE OUTLINE DIMENSIONS

TSSOP-16

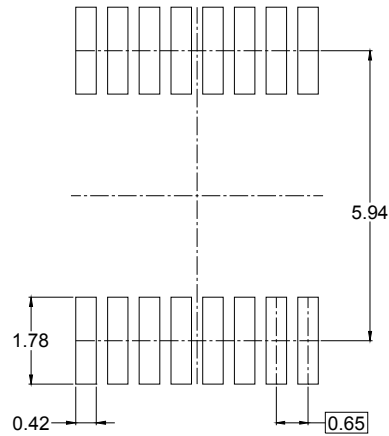
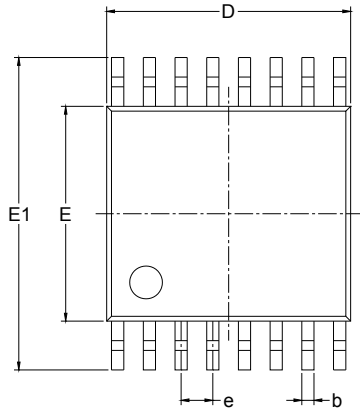

RECOMMENDED LAND PATTERN (Unit: mm)

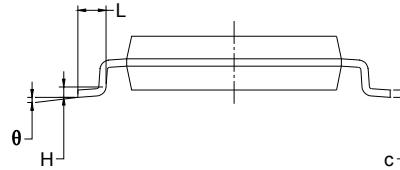
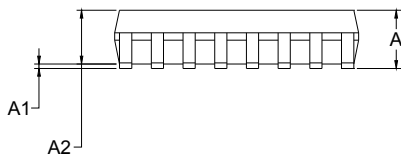

Symbol	Dimensions In Millimeters		Dimensions In Inches	
	MIN	MAX	MIN	MAX
A		1.100		0.043
A1	0.050	0.150	0.002	0.006
A2	0.800	1.000	0.031	0.039
b	0.190	0.300	0.007	0.012
c	0.090	0.200	0.004	0.008
D	4.900	5.100	0.193	0.201
E	4.300	4.500	0.169	0.177
E1	6.250	6.550	0.246	0.258
e	0.650 BSC		0.026 BSC	
L	0.500	0.700	0.02	0.028
H	0.25 TYP		0.01 TYP	
θ	1°	7°	1°	7°

TAPE AND REEL INFORMATION

REEL DIMENSIONS

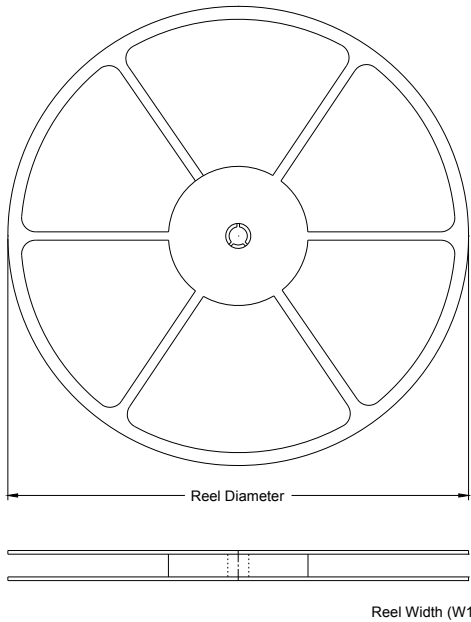

TAPE DIMENSIONS

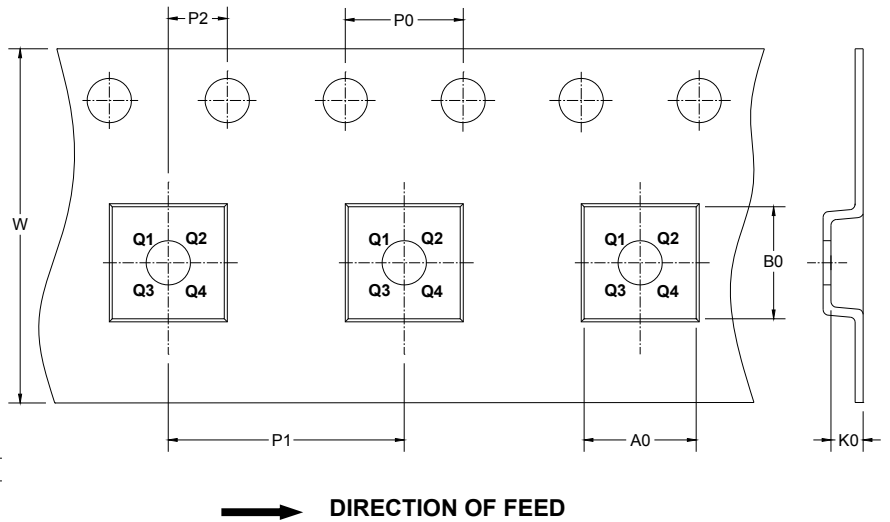

NOTE: The picture is only for reference. Please make the object as the standard.

KEY PARAMETER LIST OF TAPE AND REEL

Package Type	Reel Diameter	Reel Width W1 (mm)	A0 (mm)	B0 (mm)	K0 (mm)	P0 (mm)	P1 (mm)	P2 (mm)	W (mm)	Pin1 Quadrant
TQFN-3×3-16L	13"	12.40	3.35	3.35	1.13	4.00	4.00	2.00	12.00	Q1
TSSOP-16	13"	12.4	6.9	5.6	1.2	4.0	8.0	2.0	12.0	Q1

SGM84782

4Ω, High Speed, Low Voltage Analog Switch/Multiplexer

CARTON BOX DIMENSIONS

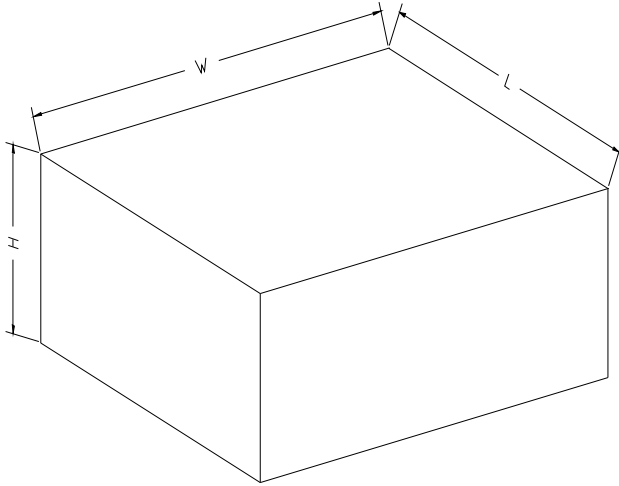

NOTE: The picture is only for reference. Please make the object as the standard.

KEY PARAMETER LIST OF CARTON BOX

Reel Type	Length (mm)	Width (mm)	Height (mm)	Pizza/Carton
13"	386	280	370	5