

GHA300F

GH A 300 F -□□ -□
 ① ② ③ ④ ⑤ ⑥

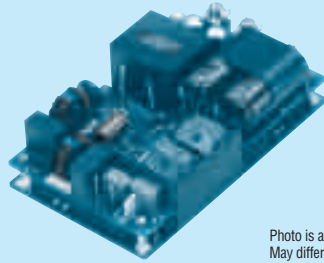

Recommended EMI/EMC Filter
 EAC-10-472

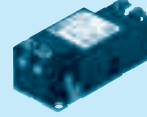

High voltage pulse noise type : EAP series
 Low leakage current type : EAM series
 *The EMI/EMC Filter is recommended to connect with several devices.

- ① Series name
 - ② Single output
 - ③ Output wattage
 - ④ Universal input
 - ⑤ Output voltage
 - ⑥ Optional *6
- T3 : mounting hole M3
 J1 : VH(J.S.T.)connector type
 R3 : with Subfeatures (5VAUX,12VAUX,Remote, Power good)

Information the Home page is the latest.

Photo is an image of the appearance. May differ from the actual product.

Specification is changed at option, refer to Instruction manual.

[Cautions]

- * Forced air cooling is required for the maximum output power. Please see instruction manual.
 - * This power supply requires mounting on metal standoffs 5mm in height. Insulation sheet is required if standoff is not used or less than 5mm clearance is needed.
 - * Avoid applying stress to surface mount components.
 - * De-rating is required if the applied input voltage is 90-115VAC.
 - * The electrolytic capacitor has limited life span which is very much dependent on the actual operating conditions.
 - * Operating in the presence of chemical vapors or harsh environment can affect the power supply life expectancy.
 - * Please make sure to read the instruction manual carefully before using this product.
- It should be in the "Instruction Manual" not spec sheet.

MODEL	GHA300F-12		GHA300F-24		GHA300F-48	
MAX OUTPUT WATTAGE[W]	300		300		302.4	
DC OUTPUT	Forced air	at 50°C	12V 25A	24V 12.5A	48V 6.3A	
		at 40°C	12V 8.4A	24V 4.2A	48V 2.1A	
	Convection	at 50°C	12V 4.5A	24V 2.2A	48V 1.1A	

SPECIFICATIONS

	MODEL	GHA300F-12	GHA300F-24	GHA300F-48	
INPUT	VOLTAGE[V]	AC90 - 264 1 φ (output derating is required at AC90V -115V *3)			
	CURRENT[A]	ACIN 120V	3.3typ		
		ACIN 230V	1.8typ		
	FREQUENCY[Hz]	50 / 60 (47 - 63)			
	EFFICIENCY[%]	ACIN 120V	89typ	90typ	90typ
		ACIN 230V	91typ	92typ	92typ
	POWER FACTOR (Io=100%)	ACIN 120V	0.95typ		
		ACIN 230V	0.90typ		
INRUSH CURRENT[A]	ACIN 120V	20typ (Io=100%) (At cold start) (Ta=25°C)			
	ACIN 230V	40typ (Io=100%) (At cold start) (Ta=25°C)			
LEAKAGE CURRENT[ma]	0.125/0.250max (ACIN 120V/240V 60Hz,Io=100%, According to IEC60601-1)				
OUTPUT	VOLTAGE[V]	12	24	48	
	CURRENT[A]	Forced air	25	12.5	6.3
		Convection	4.5	2.2	1.1
	LINE REGULATION[mV] *4	48max	96max	192max	
	LOAD REGULATION[mV] *4	100max	150max	240max	
	RIPPLE[mVp-p] *1	0 to +50°C	240max	240max	300max
		-20 to 0°C	320max	320max	400max
	RIPPLE NOISE[mVp-p]*1	0 to +50°C	300max	300max	480max
		-20 to 0°C	360max	360max	500max
	TEMPERATURE REGULATION[mV]	0 to +50°C	120max	240max	480max
		-20 to +50°C	150max	290max	600max
	DRIFT[mV] *2	48max	96max	192max	
	START-UP TIME[ms]	500typ (ACIN 120V, Io=100%)			
	HOLD-UP TIME[ms]	16typ (ACIN 120V, Io=100%)			
OUTPUT VOLTAGE ADJUSTMENT RANGE[V]	10.80 to 13.20	21.60 to 26.40		43.20 to 52.80	
OUTPUT VOLTAGE SETTING[V]	12.00 to 12.48	24.00 to 24.96		48.00 to 49.92	
PROTECTION CIRCUIT AND OTHERS	OVERCURRENT PROTECTION	Works over 105% of rating and recovers automatically			
	OVERVOLTAGE PROTECTION[V]	13.80 to 16.80	27.60 to 33.60	55.20 to 67.20	
	AUX1 (12V1A)	Optional			
	AUX2 (5V1A)	Optional			
	REMOTE ON/OFF	Optional			
PowerGood	Optional				
ISOLATION	INPUT-OUTPUT · RC · AUX *7	AC4,000V 1minute, Cutoff current = 10mA, DC500V 50MΩ min (At Room Temperature)			
	INPUT-FG	AC2,000V 1minute, Cutoff current = 10mA, DC500V 50MΩ min (At Room Temperature)			
	OUTPUT · RC · AUX-FG *7	AC500V 1minute, Cutoff current = 25mA, DC500V 50MΩ min (At Room Temperature)			
	OUTPUT-RC · AUX *7	AC500V 1minute, Cutoff current = 25mA, DC500V 50MΩ min (At Room Temperature)			
ENVIRONMENT	OPERATING TEMP.,HUMID.AND ALTITUDE	-20 to +70°C, 20 - 90%RH (Non condensing)			
	STORAGE TEMP.,HUMID.AND ALTITUDE	-30 to +75°C, 20 - 90%RH (Non condensing)			
	VIBRATION	10 - 55Hz, 19.6m/s ² (2G), 3minutes period, 60minutes each along X, Y and Z axis			
	IMPACT	196.1m/s ² (20G), 11ms, once each X, Y and Z axis			
SAFETY AND NOISE REGULATIONS	AGENCY APPROVALS	UL60950-1, ANSI/AMII ES60601-1, C-UL, EN60950-1, EN60601-1			
	CONDUCTED NOISE	Complies with FCC-B, VCCI-B, CISPR11-B, CISPR22-B, EN55011-B, EN55022-B			
	HARMONIC ATTENUATOR	Complies with IEC61000-3-2 (class A) *5			
OTHERS	CASE SIZE/WEIGHT	76.2×35×127mm [3.0×1.4×5.0 inches] (W×H×D) / 400g max			
	COOLING METHOD	Convection, Forced air (Require external fan)			

*1 This is the value that measured on measuring board with capacitor of 22μF at 150mm from output terminal.
 Measured by 20MHz oscilloscope or Ripple-Noise meter (Equivalent to KEISOKU-GIKEN: RM103).
 *2 Drift is the change in DC output for an eight hour period after a half-hour warm-up at 25°C, with the input voltage held constant at the rated input/output.
 *3 Derating is required.
 *4 Please contact us about dynamic load and input response.

*5 Please contact us about another class.
 *6 Specification is changed at option, refer to Instruction Manual.
 *7 Applicable when AUX and remote control (optional) is added.
 * To meet the specifications. Do not operate over-loaded condition.
 * Sound noise may be generated by power supply in case of pulse load.
 * Parallel operation is not possible.

Features

- High Power density: 14.3W/inch³
- High efficiency 92% typ (Input Voltage 230V, Output Voltage 24V)
- 3" × 5" standard footprint
- Fits 1U applications
- Industrial and Medical safety approvals
- Low leakage current
- With Remote On/Off (Optional)
- With AUX1 (5V), AUX2 (12V) (Optional)
- No minimum load is required

Block diagram

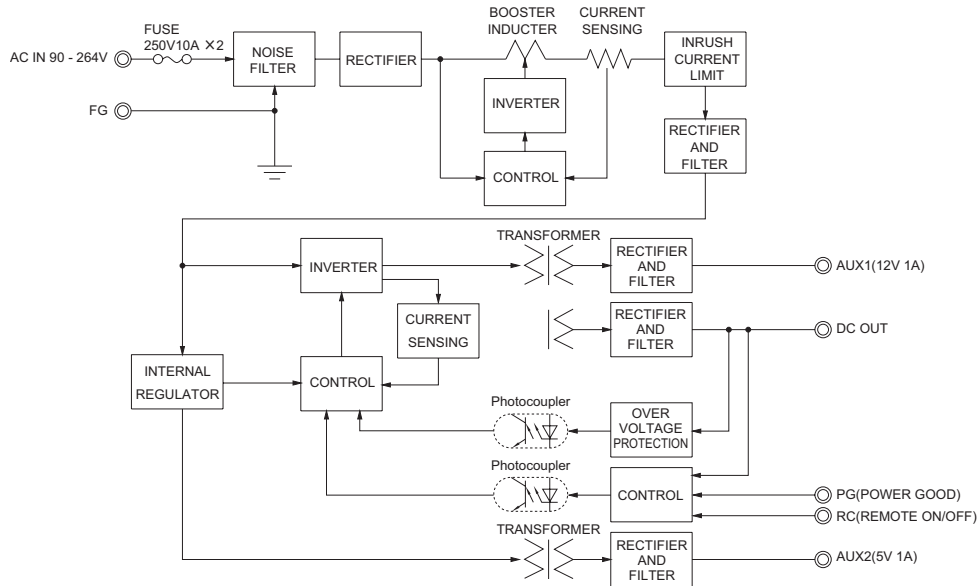

External view

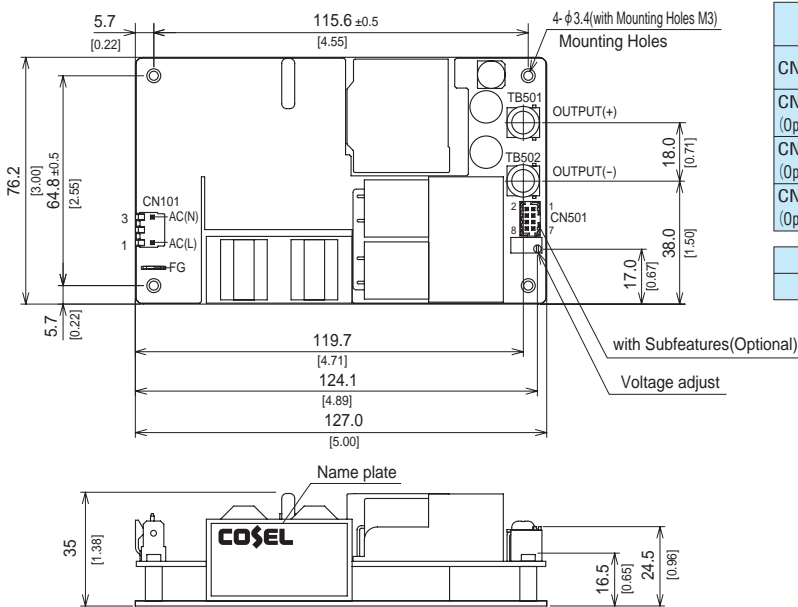

I/O Connector	Mating connector	Terminal	Mfr
CN101	A-41671-A03A197-2	09-50-8031	MOLEX
CN501 (Optional)	087831-0820	51110-0851	
CN101 (Optional)	B2P3-VH	VHR-3N	J.S.T.
CN501 (Optional)	B8B-PHDSS	PHDR-08VS	

FG	Mating connector	Terminal	Mfr
-	250 Series	-	170603-2 Tyco Electronics

<Pin Assignments>

<CN101>

Pin No.	Input
1	AC(L)
2	
3	AC(N)

<CN501(Optional)>

Pin No.	Function
1	AUX1 : AUX1 (12V1A)
2	AUX1G: AUX1 (GND)
3	RC1 : REMOTE ON/OFF
4	RCG : REMOTE ON/OFF (GND)
5	PG : Power good
6	PGG : Power good (GND)
7	AUX2 : AUX2 (5V1A)
8	AUX2G: AUX2 (GND)

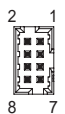

CN501

- ※ Tolerance ±1 [±0.04]
- ※ Weight : 400g max
- ※ There is a total of four attachment holes.
- ※ This power supply requires mounting on metal standoffs 5mm in height. (Insulating sheet is required if you do not use a spacer).
- ※ Dimensions in mm, []=inches
- ※ Screw tightening torque : (TB501, 502) : 1.5N · m max
- ※ Mounting torque : 0.6N · m max
- ※ Avoid contact between TB501 and 502 wiring with mounting parts.
- ※ Option : -J1 : (J.S.T) connector type. Refer to Instruction Manual 5.

GHA500F

GH A 500 F -□□ -□
 ① ② ③ ④ ⑤ ⑥

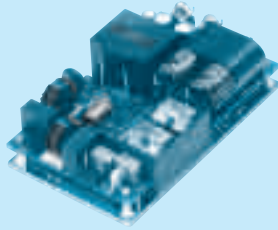

Photo is an image of the appearance. May differ from the actual product.

Recommended EMI/EMC Filter
EAC-10-472



High voltage pulse noise type : EAP series
 Low leakage current type : EAM series

*The EMI/EMC Filter is recommended to connect with several devices.

- ① Series name
- ② Single output
- ③ Output wattage
- ④ Universal input
- ⑤ Output voltage
- ⑥ Optional *6
- T3 : mounting hole M3
- J1 : VH(J.S.T.)connector type
- R3 : with Subfeatures (5VAUX,12VAUX, Remote, Power good)
- P : Pallarel Operation

[Cautions]

- Forced air cooling is required for the maximum output power. Please see instruction manual.
 - Avoid applying stress to surface mount components.
 - De-rating is required if the applied input voltage is 90-115VAC.
 - The electrolytic capacitor has limited life span which is very much dependent on the actual operating conditions.
 - Operating in the presence of chemical vapors or harsh environment can affect the power supply life expectancy.
 - Please make sure to read the instruction manual carefully before using this product.
- It should be in the "Instruction Manual" not spec sheet.

Specification is changed at option, refer to Instruction manual.

MODEL	GHA500F-12	GHA500F-15	GHA500F-24	GHA500F-48
MAX OUTPUT WATTAGE[W]	500.8	501	504	504
DC OUTPUT	Forced air at 50°C	12V 41.7A	15V 33.4A	24V 21.0A
	Convection at 40°C	12V 12.5A	15V 10.0A	24V 6.3A
	at 50°C	12V 9.2A	15V 7.4A	24V 4.6A
	conduction cooling at 0°C	12V 30.0A	15V 24.0A	24V 15.0A
	at 50°C	12V 16.7A	15V 13.4A	24V 8.4A

SPECIFICATIONS

MODEL	GHA500F-12	GHA500F-15	GHA500F-24	GHA500F-48		
INPUT	VOLTAGE[V]	AC90 - 264 1 φ (output derating is required at AC90V -115V *3)				
	CURRENT[A]	ACIN 120V	5.4typ			
		ACIN 230V	2.9typ			
	FREQUENCY[Hz]	50 / 60 (47 - 63)				
	EFFICIENCY[%]	ACIN 120V	88typ	90typ	90typ	
		ACIN 230V	90typ	92typ	92typ	
	POWER FACTOR (Io=100%)	ACIN 120V	0.95typ			
		ACIN 230V	0.90typ			
INRUSH CURRENT[A]	ACIN 120V	20typ (Io=100%) (At cold start) (Ta=25°C)				
	ACIN 230V	40typ (Io=100%) (At cold start) (Ta=25°C)				
LEAKAGE CURRENT[mA]	0.125/0.250max (ACIN 120V/240V 60Hz, Io=100%, According to IEC60601-1)					
OUTPUT	VOLTAGE[V]	12	15	24	48	
	CURRENT[A]	Forced air	41.7	33.4	21.0	10.5
		Convection	9.2	7.4	4.6	2.3
		conduction cooling	16.7	13.4	8.4	4.2
	LINE REGULATION[mV] *4	48max	60max	96max	192max	
	LOAD REGULATION[mV] *4	100max	120max	150max	240max	
	RIPPLE[mVp-p] *1	0 to +50°C	240max	240max	240max	300max
		-20 - 0°C	320max	320max	320max	400max
	RIPPLE NOISE[mVp-p]*1	0 to +50°C	300max	300max	300max	480max
		-20 - 0°C	360max	360max	360max	500max
	TEMPERATURE REGULATION[mV]	0 to +50°C	120max	120max	240max	480max
		-20 to +50°C	150max	150max	290max	600max
	DRIFT[mV] *2	48max	60max	96max	192max	
	START-UP TIME[ms]	500typ (ACIN 120V, Io=100%)				
HOLD-UP TIME[ms]	16typ (ACIN 120V, Io=100%)					
OUTPUT VOLTAGE ADJUSTMENT RANGE[V]	10.80 to 13.20	13.50 to 16.50	21.60 to 26.40	43.20 to 52.80		
OUTPUT VOLTAGE SETTING[V]	12.00 to 12.48	15.00 to 15.30	24.00 to 24.96	48.00 to 49.92		
PROTECTION CIRCUIT AND OTHERS	OVERCURRENT PROTECTION	Works over 105% of rating and recovers automatically				
	OVERVOLTAGE PROTECTION[V]	13.80 to 16.80	17.25 to 21.00	27.60 to 33.60	55.20 to 67.20	
	AUX1 (12V1A)	Optional				
	AUX2 (5V1A)	Optional				
	REMOTE ON/OFF	Optional				
ISOLATION	PowerGood	Optional				
	INPUT-OUTPUT · RC · AUX *7	AC4,000V 1minute, Cutoff current = 10mA, DC500V 50MΩ min (At Room Temperature)				
	INPUT-FG	AC2,000V 1minute, Cutoff current = 10mA, DC500V 50MΩ min (At Room Temperature)				
	OUTPUT · RC · AUX-FG *7	AC500V 1minute, Cutoff current = 25mA, DC500V 50MΩ min (At Room Temperature)				
ENVIRONMENT	OUTPUT-RC · AUX *7	AC500V 1minute, Cutoff current = 25mA, DC500V 50MΩ min (At Room Temperature)				
	OPERATING TEMP, HUMID. AND ALTITUDE	-20 to +80°C, 20 - 90%RH (Non condensing)				
	STORAGE TEMP, HUMID. AND ALTITUDE	-30 to +80°C, 20 - 90%RH (Non condensing)				
	VIBRATION	10 - 55Hz, 19.6m/s ² (2G), 3minutes period, 60minutes each along X, Y and Z axis				
SAFETY AND NOISE REGULATIONS	IMPACT	196.1m/s ² (20G), 11ms, once each X, Y and Z axis				
	AGENCY APPROVALS	UL60950-1, ANSI/AMII ES60601-1, C-UL, EN60950-1, EN60601-1				
	CONDUCTED NOISE	Complies with FCC-B, VCCI-B, CISPR11-B, CISPR22-B, EN55011-B, EN55022-B				
OTHERS	HARMONIC ATTENUATOR	Complies with IEC61000-3-2 (class A) *5				
	CASE SIZE/WEIGHT	76.2 × 35 × 127mm [3.0 × 1.4 × 5.0 inches] (W × H × D) / 420g max				
	COOLING METHOD	Convection, Forced air (Require external fan), Conduction cooling				

*1 This is the value that measured on measuring board with capacitor of 22 μF at 150mm from output terminal.
 Measured by 20MHz oscilloscope or Ripple-Noise meter (Equivalent to KEISOKU-GIKEN: RM103).
 *2 Drift is the change in DC output for an eight hour period after a half-hour warm-up at 25°C, with the input voltage held constant at the rated input/output.
 *3 Derating is required.
 *4 Please contact us about dynamic load and input response.

*5 Please contact us about another class.
 *6 Specification is changed at option, refer to Instruction Manual.
 *7 Applicable when AUX and remote control (optional) is added.
 * To meet the specifications. Do not operate over-loaded condition.
 * Sound noise may be generated by power supply in case of pulse load.
 * Parallel operation is not possible.

Features

- **Wattage 500W max**
- **High Power density:24.1W/inch³**
- **High efficiency 92% typ (Input Voltage 230V,Output Voltage 24V)**
- **Conduction cooling**
- **3" × 5" standard footprint**
- **Fits 1U applications**
- **Industrial and Medical safety approvals**
- **Low leakage current**
- **With Remote On/Off (Optional)**
- **With AUX1 (5V), AUX2 (12V) (Optional)**
- **No minimum load is required**

Block diagram

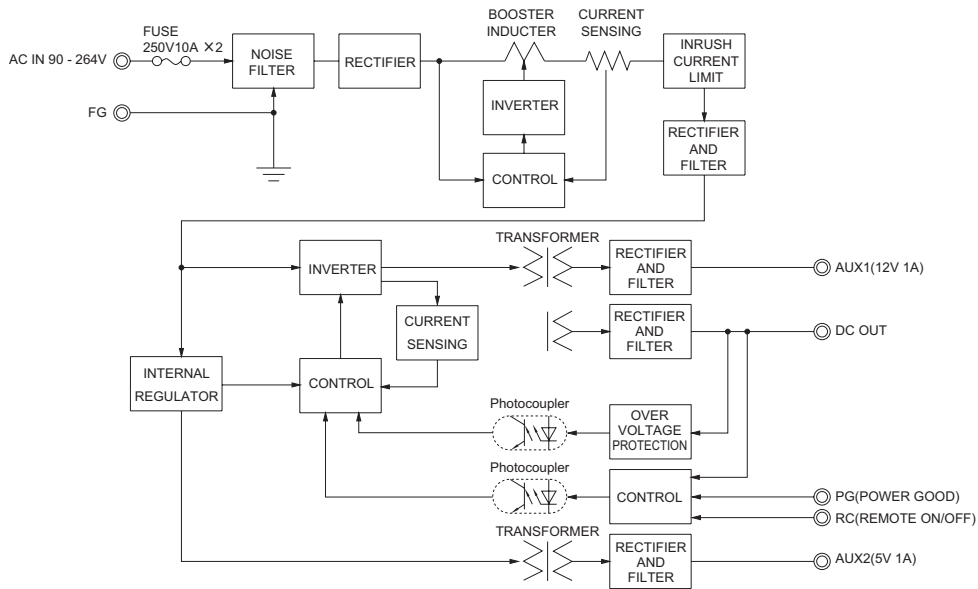

External view

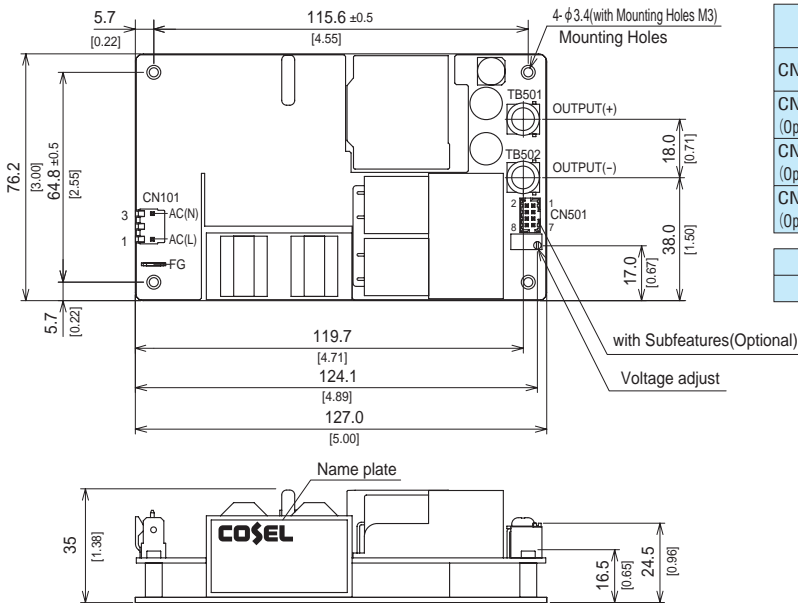

I/O Connector	Mating connector	Terminal	Mfr	
CN101	A-41671-A03A197-2	08-50-0105 08-65-0114	MOLEX	
CN501 (Optional)	087831-0820	51110-0851		50394-8051
CN101 (Optional)	B2P3-VH	VHR-3N	SVH-21T-P1.1	J.S.T.
CN501 (Optional)	B8B-PHDSS	PHDR-08VS	SPHD-002T-P0.5	

FG	Mating connector	Terminal	Mfr
-	250 Series	-	170603-2 Tyco Electronics

<Pin Assignments>

<CN101>

Pin No.	Input
1	AC(L)
2	
3	AC(N)

<CN501(Optional)>

Pin No.	Function
1	AUX1 : AUX1 (12V1A)
2	AUX1G: AUX1 (GND)
3	RC1 : REMOTE ON/OFF
4	RCG : REMOTE ON/OFF (GND)
5	PG : Power good
6	PGG : Power good (GND)
7	AUX2 : AUX2 (5V1A)
8	AUX2G: AUX2 (GND)

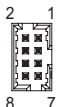

CN501

- ※ Tolerance ± 1 [± 0.04]
- ※ Weight : 420g max
- ※ There is a total of four attachment holes.
- ※ Base Plate : Aluminum
- ※ Dimensions in mm, []=inches
- ※ Screw tightening torque : (TB501, 502) : 1.5N · m max
- ※ Mounting torque : 0.6N · m max
- ※ Avoid contact between TB501 and 502 wiring with mounting parts.
- ※ Option : -J1 : (J.S.T) connector type. Refer to Instruction Manual 5.