



LT1085 3.0A LOW DROPOUT POSITIVE REGULATOR

Features:

- Output Current - 3A
- Maximum Input Voltage – 12V
- Adjustable Output Voltage or Fixed
- 1.5V, 1.8V, 2.5V, 2.85V, 3.3V, 3.6V, 5V
- Current Limiting and Thermal Protection
- Standard 3-Pin Power Packages

Applications:

- Post Regulator for Switching DC/DC Converter
- High Efficiency Linear Regulators
- Battery Charger

Operating Ratings:

Junction Temperature Range: -10°C to 125°C

Ordering Information:

Parameter Number	Package
LT1085	TO-3P
LT1085T	TO-220
LT1085D	TO-252

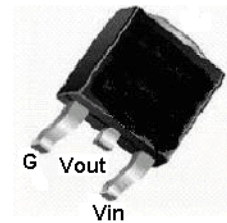
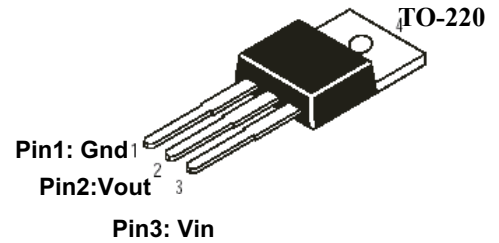
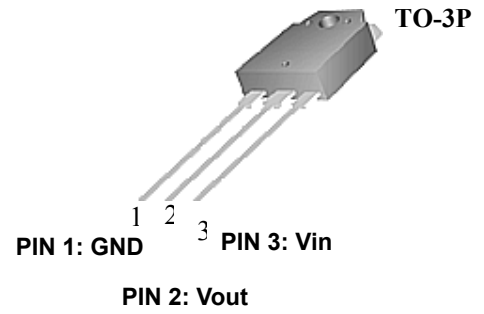

Block Diagram

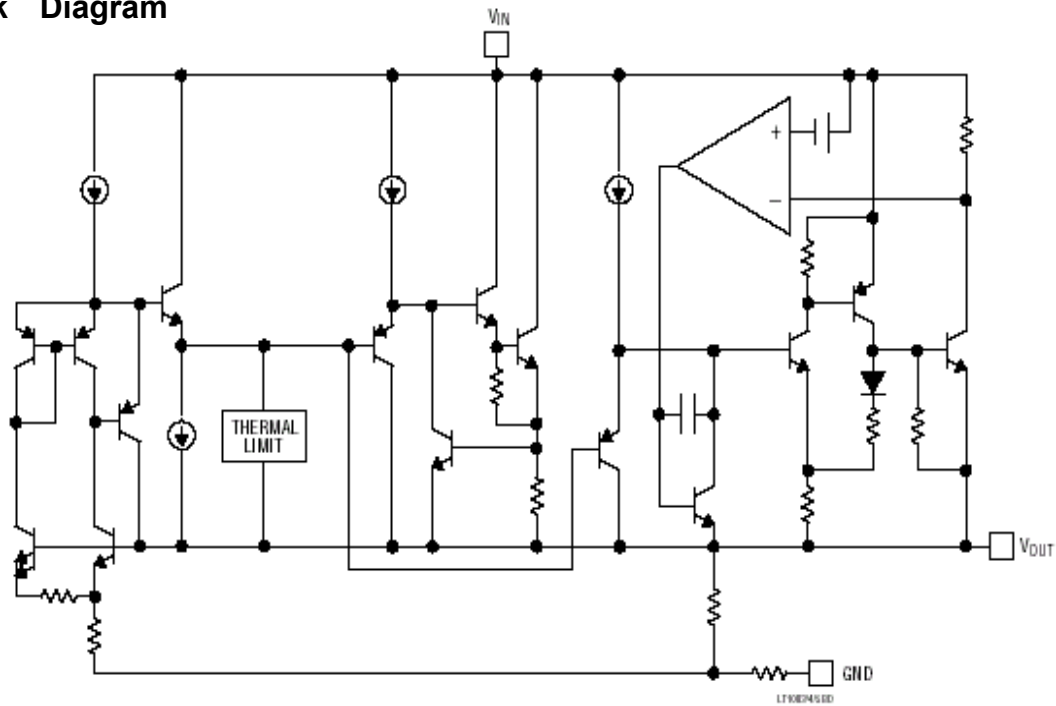



LT1085 3.0A LOW DROPOUT POSITIVE REGULATOR

Block Diagram

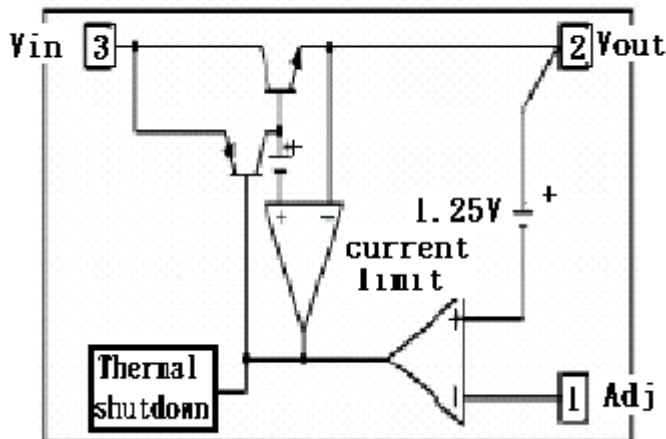

Marking

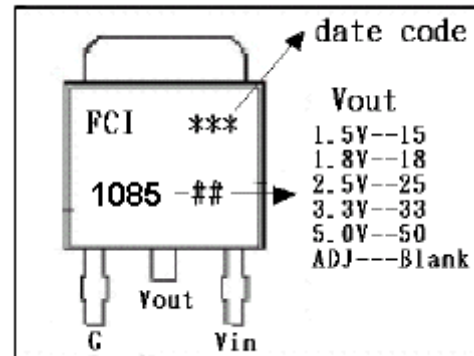

Pin Descriptions

Name	I/O	PIN#	FUNCTION
Adj (GND)		1	Adjustable (Ground only for fixed mode)
Vout	O	2	The output of the regulator. A minimum of 10uF capacitor must be connected from this pin to ground to insure stability.
Vin	I	3	The input pin of regulator. Typically a large storage capacitor is connected from this pin to ground to insure that the input voltage does not sag below the minimum dropout voltage during the load transient response. This pin must always be 1.4V higher than Vout in order for the device to regulate properly.

Absolute Maximum Ratings

Symbol	Parameter	Ratings	Unit
Vin	DC Supply Voltage	-0.3 to 12	V
P _D	Power Dissipation	Internally Limited	
T _{ST}	Storage Temperature	-65 ~ +150	°C
T _{OP}	Operating Junction Temperature Range	0 ~ +150	°C



LT1085 3.0A LOW DROPOUT POSITIVE REGULATOR

Electrical Characteristics:

Typicals and limits appearing in normal type apply for $T_j=25^\circ\text{C}$.

Limits appearing in Boldface type apply over the entire junction temperature range for operation

Symbol	Parameter	Conditions	Min	Typ	Max	Units
Vref Ripple rejection	Reference Voltage F=120Hz, Cout=25uF,	I_o=10mA, T_j=25C, (Vin-Vout)=1.5V Tantalum, I _o =3A, Vin=Vout+3A	1.225	1.250 60	1.275 70	V dB
Line Regu Load Regu	LT1085-xxx LT1085-Adj	I _o =10mA, Vout+1.5V<Vin<12V, T _j =25C Vin=3.3, 0mA<I _o <3A. T _j =25C Note 1, 2	- -	- -	0.2 1.0	%
Output Regu Load Regu	LT1085-1.5	I _o =10mA, T _j =25C, 3V<Vin<12V Vin=3.0V, 0mA<I _o <3A. T _j =25C Note 1, 2	1.470	1.500 12	1.530 15	V mV
Output Regu Load Regu	LT1085-1.8	I _o =10mA, T _j =25C, 3.3V<Vin<12V Vin=3.3V, 0mA<I _o <3A. T _j =25C Note 1, 2	1.764	1.800 15	1.836 18	V mV
Output Regu Load Regu	LT1085-2.5	I _o =10mA, T _j =25C, 4V<Vin<12V Vin=4.0V, 0mA<I _o <3A. T _j =25C Note 1, 2	2.450	2.500 20	2.55 25	V mV
Output Regu Load Regu	LT1085-3.3	I _o =10mA, T _j =25C, 4.8V<Vin<12V Vin=5.0V, 0mA<I _o <3A. T _j =25C Note 1, 2	3.235	3.3 26	3.365 33	V mV
Output Regu Load Regu	LT1085-5.0	I _o =10mA, T _j =25C, 6.5V<Vin<12V Vin=8.0V, 0mA<I _o <3A. T _j =25C Note 1, 2	4.9	5.0 40	5.10 50	V mV
ΔV	Dropout Voltage	I _o =3.0A(Δ Vout=1% Vout)	-	1.3	1.4	V
	Current Limite	Vin-Vout=5V	3.1	-	-	A
	Mini Load Current	0C<T _j <125C	-	5.0	10.0	mA
	Temperature Stability	I _o =10mA	-	0.5	-	%
ThjA	Thermal Regulation Thermal Resistivity Junction-Ambient	Ta=25C, 30ms pulse	-	0.008 98	0.04 -	%/W C/W
ThjC	Thermal Resistivity Junction-Case		-	15	-	

Note1: See Thermal Regulation specifications for changes in output vol. due to heating effects. line and load regulation are measured at a constant junction Temp. by low duty cycle pulse testing. Load regulation is measured at the output lead=1/8" from the package

Note2: Line and load Regulation are guaranteed up to the max power dissipation of 15W power dissipation is determined by the difference between input and output and the current. Guaranteed max power dissipation will not be available over the full input/output range

Note3: Quiescent current is defined as the mini output current required in maintaining regulation. At 12V input /output differential the device is guaranteed to regulate if the output current is greater than 10mA



3A Low Dropout Positive Adjustable or Fixed-Mode Regulator

Description

The LT1085 is a low dropout positive adjustable or fixed-mode regulator with minimum of 3A output current capability. The product is specifically designed to provide well-regulated supply for low voltage IC applications such as high-speed bus termination and low current 3.3V logic supply. LT1085 is also well suited for other applications such as VGA cards. LT1085 is guaranteed to have <1.4V dropout at full load current making it ideal to provide well-regulated outputs of 1.25 to 5.0V with 4.7 to 12V input supply by different output voltage.

Features

- 3-Terminal Adjustable or fixed 1.5V, 1.8V, 2.5V, 3.3V, 5.0V
- 1.4V Maximum Dropout at Full Load current
- Fast Transient response
- Built-in Thermal Shutdown

Functional Description

Introduction

The LT1085 adjustable or fixed-mode Low Dropout (LDO) regulator is a 3 terminal device which can easily be programmed by internal mask change to any voltage within the range of 1.25 to $V_{in}-1.4V$. The LT1085 only needs 1.4V differential between V_{in} and V_{out} to maintain output regulation, in addition, the output voltage tolerances are also extremely tight and they include the transient response as part of the specification. For example, Intel VRE specification calls for a total of $\pm 100mV$ including initial tolerance, load regulation and 0 to 3A load step. The LT1085 is specifically designed to meet the fast current transient needs as well as providing an accurate initial voltage, reducing the overall system cost with the need for fewer output capacitors.

Load Regulation

Since the LT1085 is only a 3 terminal device, it is not possible to provide true remote sensing of the output voltage at the load. But it can supply good load regulation by internal feedback bypass the external loss such as adjustable mode.

Stability

The LT1085 requires the use of an output capacitor as part of the frequency compensation in order to make the regulator stable. For most applications a minimum of 10 μF aluminum electrolytic capacitor insures both stability and good transient response.

Thermal Design

The LT1085 incorporates an internal shutdown that protects the device when the junction temperature exceeds the maximum allowable junction temperatures. Although this device can operate with junction temperatures in the range of 150°C, it is recommended that the selected heat sink be chosen such that during maximum continuous load operation the junction temperature is kept below the temperature.

Layout Consideration

The output capacitors must be located as close to the V_{out} terminal of the device as possible. It is recommended to use a section of a layer of the PC board as a plane to connect the V_{out} pin to the output capacitors to prevent any high frequency oscillation that may result due to excessive trace inductance.



Typical Performance Characteristics

