



AP4400A

Ultra Low Power Voltage Detector

1. General Description

The AP4400A is ultra-low power consumption and high-precision IC for voltage detection. Its consumption current is extremely low and is only 20nA typically (@3.3 V, detecting voltage). Since its consumption current is much low during the voltage monitoring, AP4400A is ideal for energy harvesting application.

2. Features

- “H” Level Detection Voltage (V_{VDETH}): 2.0 to 4.2V (0.1V step for option)
- “L” Level Detection Voltage (V_{VDETL}): 1.8 to 4.0V (0.1V step for option)
- Hysteresis Voltage: 0.2 to 2.4 V
- Operation Voltage Range 0.8 to 5.5V
- Consumption Current 20 nA typical (@ $V_{VDDIN} = 3.4$ V)
- Operation temperature $T_a = -15 \sim 85$ °C
- Package Type TMSOP 10-pin

3. Table of Contents

1. General Description	1
2. Features	1
3. Table of Contents.....	2
4. Block Diagram.....	3
■ Block Diagram.....	3
5. Ordering Guide	3
6. Pin Configurations and Functions.....	4
■ Pin Configurations.....	4
■ Function.....	4
7. Absolute Maximum Ratings	5
8. Recommended Operating Conditions	5
9. Electrical Characteristics.....	6
10. Description	7
11. Recommended External Circuits.....	8
12. Part Number Code.....	9
■ Product name	9
■ Part number code example	9
13. Package	10
■ Outline Dimensions	10
■ Marking	10
14. Revise History	11
IMPORTANT NOTICE.....	12

4. Block Diagram

■ **Block Diagram**

AP4400A : CMOS output type (Active “H”)

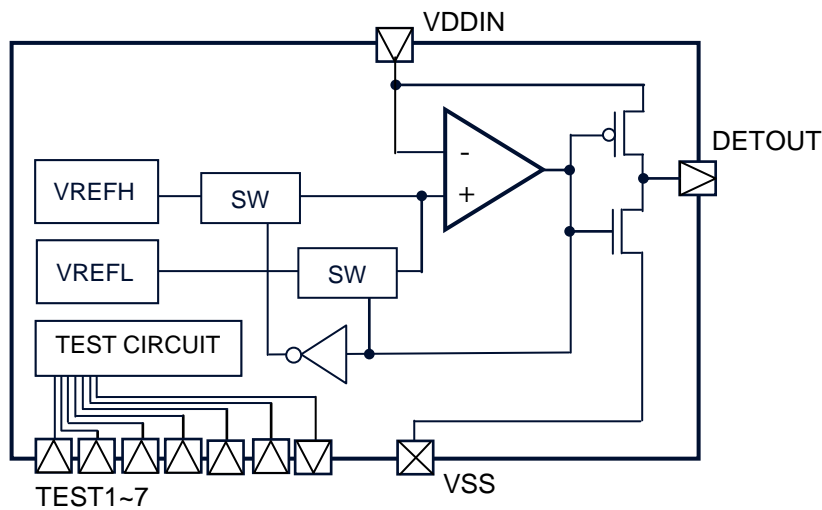

Figure 1. Block Diagram

5. Ordering Guide

AP4400AEMNM -15 to 85°C TMSOP 10-pin

Please refer to section [12.Part Number Code](#) for voltage option.

6. Pin Configurations and Functions

■ Pin Configurations

TMSOP 10-pin

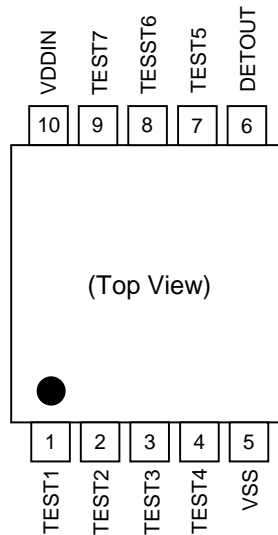

■ Function

Pin No.	Name	I/O (Note 1)	Function
1	TEST1	IN	Connect to VSS.
2	TEST2	IN	Connect to VSS.
3	TEST3	IN	Connect to VSS.
	TEST4	IN	Connect to VSS.
5	VSS	PWR	GND pin
6	DETOUT	OUT	Voltage detect output pin
7	TEST5	OUT	No Connection (Need to be Open).
8	TEST6	IN	Connect to VSS.
9	TEST7	IN	Connect to VSS.
10	VDDIN	PWR	Power pin

Note 1. PWR: Power pin (VSS or VDDIN).

7. Absolute Maximum Ratings

Parameter	Symbol	Min.	Max.	Unit
Power Supply (Note 2)	V_{VDDIN}	-0.3	6.5	V
Output Voltage (Note 2)	V_{out}	$V_{VSS} - 0.3$	$V_{VDDIN} + 0.3$	V
Output Current	I_{out}	-10	+10	mA
Power Dissipation	P_d	-	1.0	W
Storage Temperature	T_{stg}	-55	150	°C

Note 2. All voltages are with reference to $V_{VSS} = 0$ V.

WARNING: Stresses exceeding Maximum Ratings may damage the device. Normal operation is not guarantee if the condition exceeds the maximum rating.

8. Recommended Operating Conditions

Parameter	Symbol	min	typ	max	Unit	Condition
Operation Temperature	T_a	-15	-	85	°C	-
Power Voltage (Note 3)	V_{VDDIN}	0.8	-	5.5	V	-

Note 3. The output is infinite in under the condition: $V_{VDDIN} \leq 0.8$ V, adequate evaluation including temperature characteristics is necessary.

9. Electrical Characteristics

Ta = 25°C, DETOUT = open, unless otherwise specified.

Parameter	Symbol	min	typ	max	Unit	Condition
Detecting voltage (Note 4)						
“H” Level voltage	V_{VDETH}	3.2	3.3	3.4	V	$V_{VDDIN} = \text{“L”} \rightarrow \text{“H”}$
“L” Level voltage	V_{VDETL}	1.9	2.0	2.1	V	$V_{VDDIN} = \text{“H”} \rightarrow \text{“L”}$
Detection voltage temperature coefficient	$\Delta V_{DET}/\Delta Ta$	-	0.75	-	mV/°C	Ta=-15 ~ 85°C
Consumption current (Note 5)						
In V_{VDDIN} Rising	I_{DDH}	-	20	50	nA	$V_{VDDIN} = V_{VDETH} + 0.1V$
In V_{VDDIN} Falling	I_{DDL}	-	20	50	nA	$V_{VDDIN} = V_{VDETL} - 0.1V$
Level “L” output current (Note 6)	I_{OL}	0.2	-	-	mA	$V_{VDDIN} = V_{VDETL} - 0.1V$, $V_{VDDIN} - V_{DETOUT} = 0.5V$
Level “H” output current (Note 6)	I_{OH1}	0.15	-	-	mA	$V_{VDDIN} = V_{VDETH} + 0.1V$, $V_{DETOUT} - V_{VSS} = 0.5V$
Minimum operating voltage (Note 7)	V_{OPL}	-	0.4	0.8	V	
Output response (Note 4)	tPLH	-	0.12	0.25	ms	$V_{VDDIN} =$ $V_{VDETH} - 0.1V \rightarrow V_{VDETH} + 0.1V$
	tPHL	-	25	40	ms	$V_{VDDIN} =$ $V_{VDETL} + 0.1V \rightarrow V_{VDETL} - 0.1V$

Note 4. Example of detecting voltage. When ordering the product, specify the voltage. The voltage can be set in the range between 1.8 and 4.2 V in units of 0.1 V by taking into account the hysteresis voltage.

Note 5. It does not include the current for the output drive.

Note 6. Since the output current depends on V_{VDDIN} , adequate evaluation including the temperature characteristics are necessary.

Note 7. It indicates the lowest Power Voltage value in case of detected output voltage is less than 0.4V.

10. Description

- **Operation in the Voltage (V_{VDDIN}) Rising:**

When V_{VDDIN} is between V_{VSS} and the minimum operating voltage of IC, the V_{DETOUT} output is indefinite.
 When V_{VDDIN} is above the minimum operating voltage, V_{DETOUT} outputs V_{VSS} . When V_{VDDIN} is reached to V_{VDETH} , V_{DETOUT} outputs V_{VDDIN} .

- **Operation in the Voltage (V_{VDDIN}) Falling:**

When V_{VDDIN} is above V_{VDETH} , V_{DETOUT} outputs V_{VDDIN} . When V_{VDDIN} is below V_{VDETL} , V_{DETOUT} outputs V_{VSS} .
 V_{DETOUT} output becomes indefinite, when V_{VDDIN} is below the minimum operating voltage.

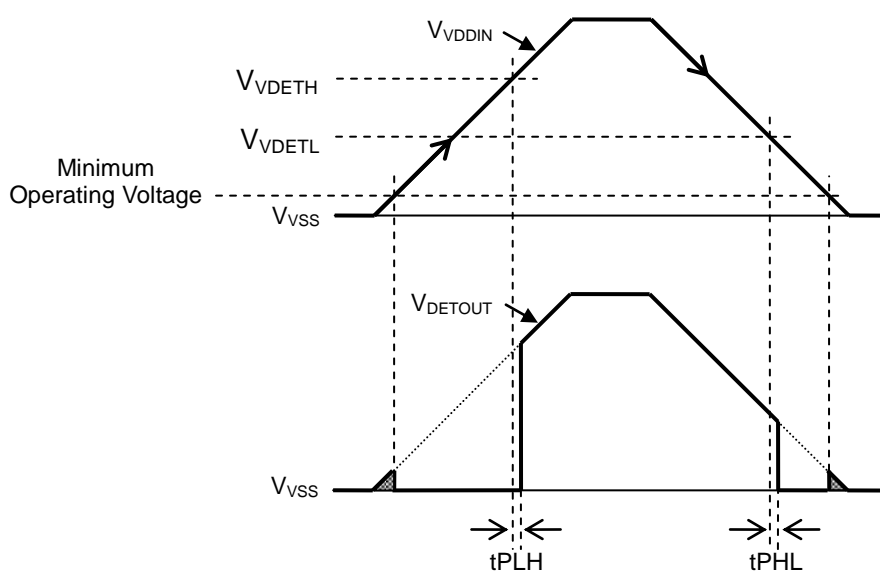

Figure 2. Operation Detail

11. Recommended External Circuits

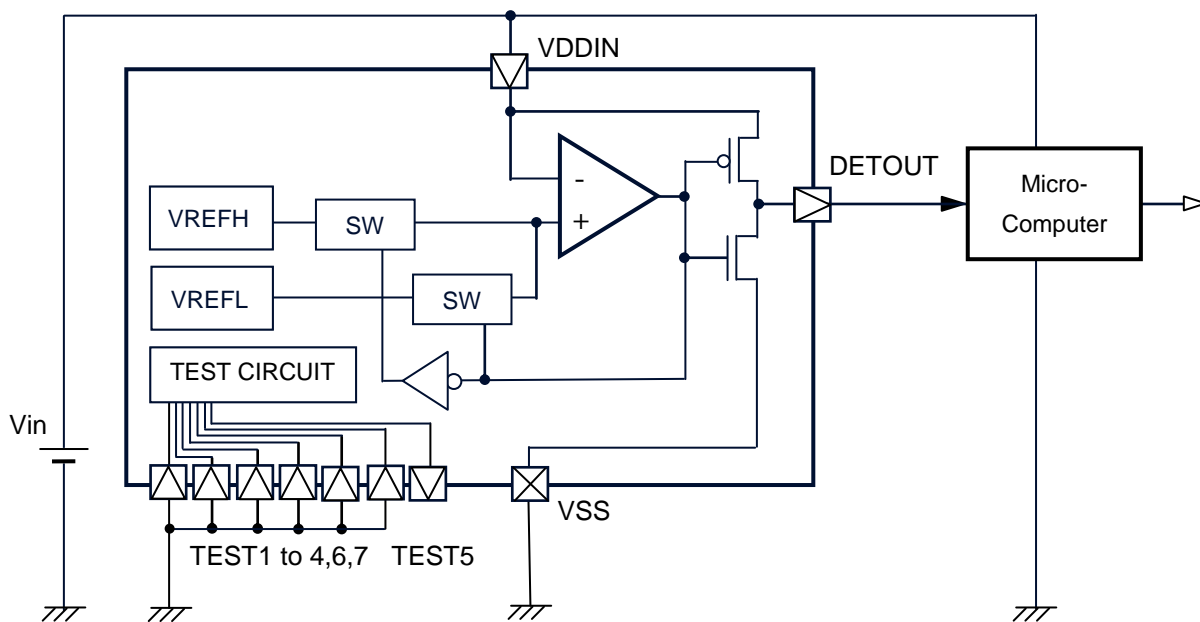

Figure 3. Typical Application Diagram

Note 8. Connect the capacitor C_{in} between V_{DDIN} and V_{SS} terminals if V_{DDIN} is dropped with V_{DETOUT} inversion.

12. Part Number Code

The detecting voltage can be selected for the AP4400A. The definition of each option is shown as below:

■ **Product name**

AP440XAEXXX

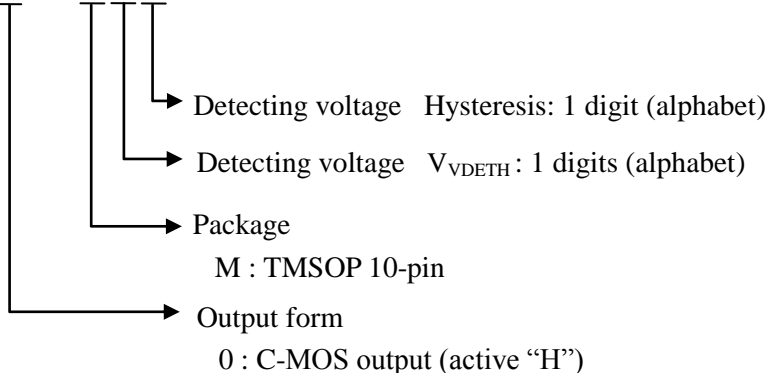

Table 1. Voltage Option

	V_{VDETH}	Hysteresis ($V_{VDETH} - V_{VDETL}$)
A	2.0	-
B	2.1	0.2
C	2.2	0.3
D	2.3	0.4
E	2.4	0.5
F	2.5	0.6
G	2.6	0.7
H	2.7	0.8
I	2.8	0.9
J	2.9	1.0
K	3.0	1.1
L	3.1	1.2
M	3.2	1.3
N	3.3	1.4
O	3.4	1.5
P	3.5	1.6
Q	3.6	1.7
R	3.7	1.8
S	3.8	1.9
T	3.9	2.0
U	4.0	2.1
V	4.1	2.2
W	4.2	2.3
X	-	2.4

■ **Part number code example**

Package : TMSOP 10-pin, $V_{VDETH} = 3.3 \text{ V}$, Hysteresis($V_{VDETH} - V_{VDETL}$)= 1.3 V

Part number code : AP4400AEMNM

13. Package

■ **Outline Dimensions**

(Unit: mm)

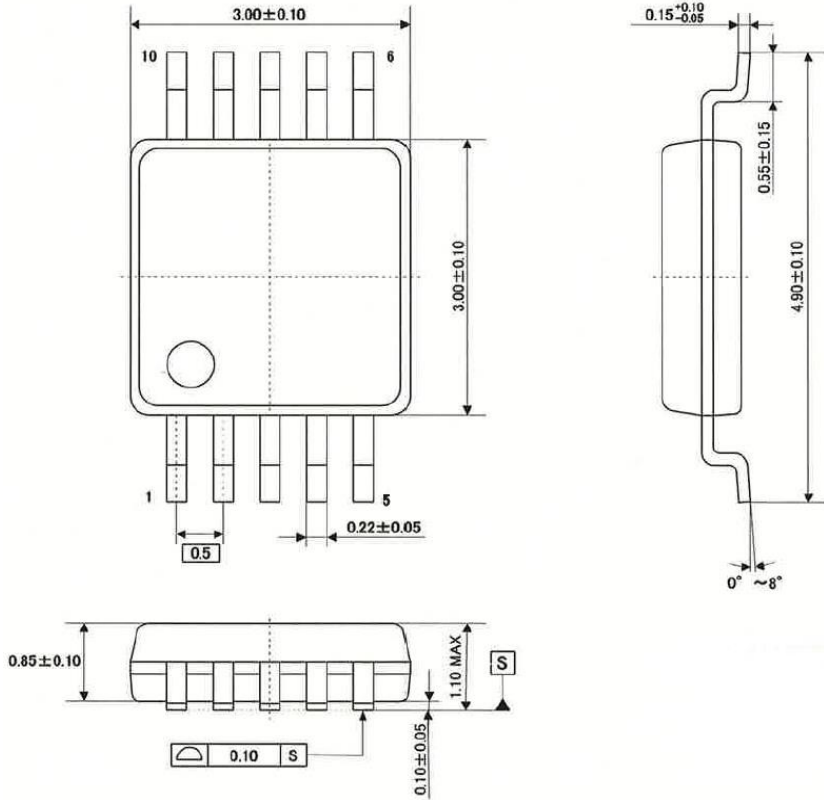

■ **Marking**

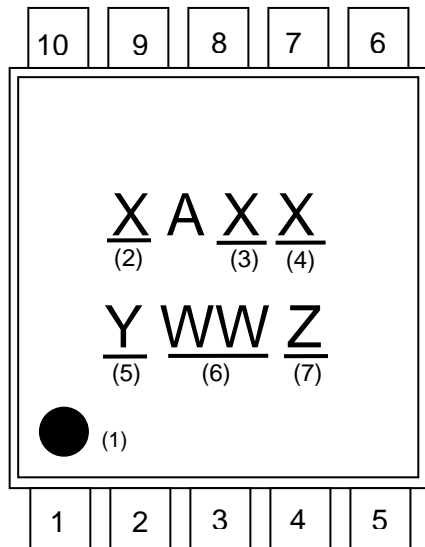

- (1) Pin 1 display
- (2) Output type
- (3) Detecting voltage (V_{VDETH})
- (4) Hysteresis
- (5) Year code (last 1 digit)
- (6) Week code
- (7) Management code

14. Revise History

Date (YY/MM/DD)	Revision	Page	Contents
14/04/17	00		First edition
14/08/27	01	P9	Correction of the explanation of product name (6th digit and last 2 digits).
15/03/04	02	P6	Error correction.

IMPORTANT NOTICE

0. Asahi Kasei Microdevices Corporation (“AKM”) reserves the right to make changes to the information contained in this document without notice. When you consider any use or application of AKM product stipulated in this document (“Product”), please make inquiries the sales office of AKM or authorized distributors as to current status of the Products.
1. All information included in this document are provided only to illustrate the operation and application examples of AKM Products. AKM neither makes warranties or representations with respect to the accuracy or completeness of the information contained in this document nor grants any license to any intellectual property rights or any other rights of AKM or any third party with respect to the information in this document. You are fully responsible for use of such information contained in this document in your product design or applications. **AKM ASSUMES NO LIABILITY FOR ANY LOSSES INCURRED BY YOU OR THIRD PARTIES ARISING FROM THE USE OF SUCH INFORMATION IN YOUR PRODUCT DESIGN OR APPLICATIONS.**
2. The Product is neither intended nor warranted for use in equipment or systems that require extraordinarily high levels of quality and/or reliability and/or a malfunction or failure of which may cause loss of human life, bodily injury, serious property damage or serious public impact, including but not limited to, equipment used in nuclear facilities, equipment used in the aerospace industry, medical equipment, equipment used for automobiles, trains, ships and other transportation, traffic signaling equipment, equipment used to control combustions or explosions, safety devices, elevators and escalators, devices related to electric power, and equipment used in finance-related fields. Do not use Product for the above use unless specifically agreed by AKM in writing.
3. Though AKM works continually to improve the Product’s quality and reliability, you are responsible for complying with safety standards and for providing adequate designs and safeguards for your hardware, software and systems which minimize risk and avoid situations in which a malfunction or failure of the Product could cause loss of human life, bodily injury or damage to property, including data loss or corruption.
4. Do not use or otherwise make available the Product or related technology or any information contained in this document for any military purposes, including without limitation, for the design, development, use, stockpiling or manufacturing of nuclear, chemical, or biological weapons or missile technology products (mass destruction weapons). When exporting the Products or related technology or any information contained in this document, you should comply with the applicable export control laws and regulations and follow the procedures required by such laws and regulations. The Products and related technology may not be used for or incorporated into any products or systems whose manufacture, use, or sale is prohibited under any applicable domestic or foreign laws or regulations.
5. Please contact AKM sales representative for details as to environmental matters such as the RoHS compatibility of the Product. Please use the Product in compliance with all applicable laws and regulations that regulate the inclusion or use of controlled substances, including without limitation, the EU RoHS Directive. AKM assumes no liability for damages or losses occurring as a result of noncompliance with applicable laws and regulations.
6. Resale of the Product with provisions different from the statement and/or technical features set forth in this document shall immediately void any warranty granted by AKM for the Product and shall not create or extend in any manner whatsoever, any liability of AKM.
7. This document may not be reproduced or duplicated, in any form, in whole or in part, without prior written consent of AKM.