

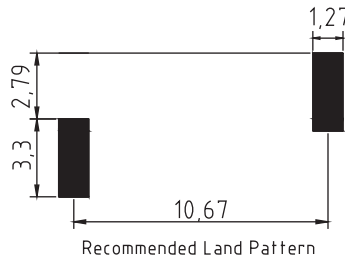

SMAC0312

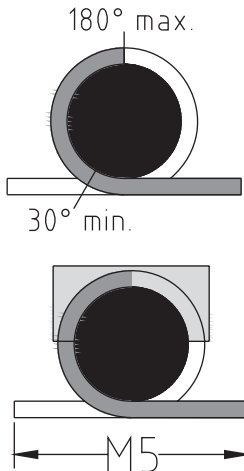

Strip Length

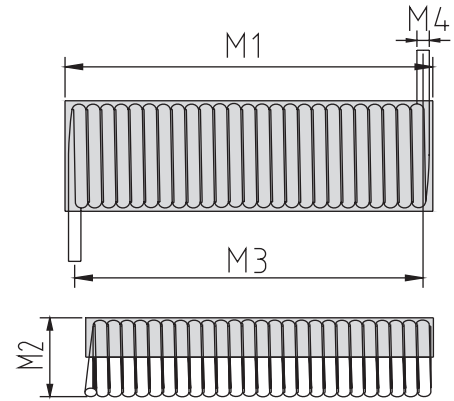

Recommended Land Pattern

UNIT: mm

	DIM.	TOL.
M1	11.68	MAX.
M2	3.30	±0.254
M3	10.67	±0.381
M4	see	table
M5	4.826	±0.76

ELECTRICAL

	INDUCTANCE (uH) @100kHz/0.1V ±10%	DCR (mOHM) MAX.	SRF (MHz) Typ.	Irms (A) @ 40°C Temp Rise	Dimension M4 MAX.
SMAC0312-1R15K	1.15	15.0	235	4.2	0.7
SMAC0312-3R25K	3.25	49.0	150	3.1	3.1

Operating Temperature -25°C ~ +125°C

(All specifications subject to change without notice)

TEST INSTRUMENT

INDUCTANCE: AGILENT/HP16193 FIXTURE IN AGILENT/ 4291B

DCR: ZENTECH 502A

SRF: AGILENT 8753E

MATERIAL LIST

WIRE: POLYESTER ENAMELED COPPER WIRE.

CORE: FERRITE Ni-Zn CORE.

EPOXY: UV COATING.