

RFXF0008

1:1 SMT Transformer
45MHz to 1200MHz

The RFXF0008 transformer is designed for applications that require small, low cost and highly reliable surface mount components. Applications may be found in broadband, wireless and other communications systems. These units are built lead-free and RoHS compliant. S-Parameters are available on request.



Package: SP6

Features

- 45MHz to 1200MHz Operation
- Low Cost and RoHS Compliant
- Industry Standard SMT Package
- Available in Tape-and-Reel
- 75 Ω Characteristic Impedance

Applications

- Broadband/CATV
- Wireless

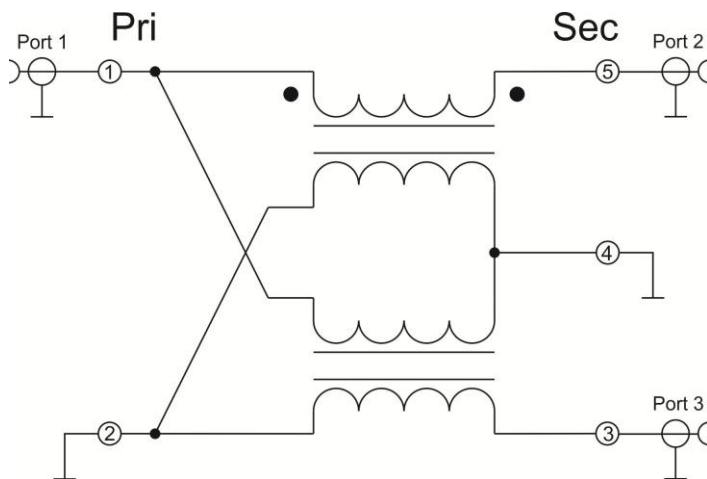

Functional Block Diagram

Ordering Information

RFXF0008SB	Sample bag with 5 pieces
RFXF0008SQ	Sample bag with 25 pieces
RFXF0008SR	13" Sample reel with 100 pieces
RFXF0008TR13	13" Reel with 1000 pieces

Absolute Maximum Ratings

Parameter	Rating	Unit
RF Power	2	W
Operating Temperature Range	-40 to +100	°C
Storage Temperature Range	-55 to +100	°C



RoHS (Restriction of Hazardous Substances): Compliant per EU Directive 2011/65/EU.

Exceeding any one or a combination of the Absolute Maximum Rating conditions may cause permanent damage to the device. Extended application of Absolute Maximum Rating conditions to the device may reduce device reliability. Specified typical performance or functional operation of the device under Absolute Maximum Rating conditions is not implied.

Nominal Operating Parameters

Parameter	Specification			Unit	Condition
	Min	Typ	Max		
General Performance					Typical values represent Mid-Band performance at T=25°C.
Operating Frequency Range	45		1200	MHz	
Insertion Loss		1.6	2.0	dB	45 MHz to 200 MHz
		1.5	2.0	dB	200 MHz to 600 MHz
		1.9	2.5	dB	600 MHz to 1000 MHz
		2.2	2.8	dB	1000 MHz to 1200 MHz
Input Return Loss	12	14		dB	45 MHz
	12	14		dB	45 MHz to 100 MHz
	15	17		dB	100 MHz to 400 MHz
	14	16		dB	400 MHz to 700 MHz
	12	16		dB	700 MHz to 1000 MHz
	11	14		dB	1000 MHz to 1200 MHz
Amplitude Balance		0.3	0.5	dB	45 MHz to 200 MHz
		0.4	1.0	dB	200 MHz to 600 MHz
		0.4	1.0	dB	600 MHz to 1000 MHz
		0.4	1.0	dB	1000 MHz to 1200 MHz
Phase Balance		2	3	°	45 MHz, Nominal Phase Difference is 180°
		5	10	°	45 MHz to 300 MHz, Nominal Phase Difference is 180°
		13	18	°	300 MHz to 600 MHz, Nominal Phase Difference is 180°
		20	26	°	600 MHz to 1000 MHz, Nominal Phase Difference is 180°
		21	26	°	1000 MHz to 1200 MHz, Nominal Phase Difference is 180°
DC Current Capability (in CT)			500	mA	
Impedance Ratio	1:2.78				
Type – Transmission Line	Balanced to Balanced				

Typical Performance: T=25°C unless otherwise noted

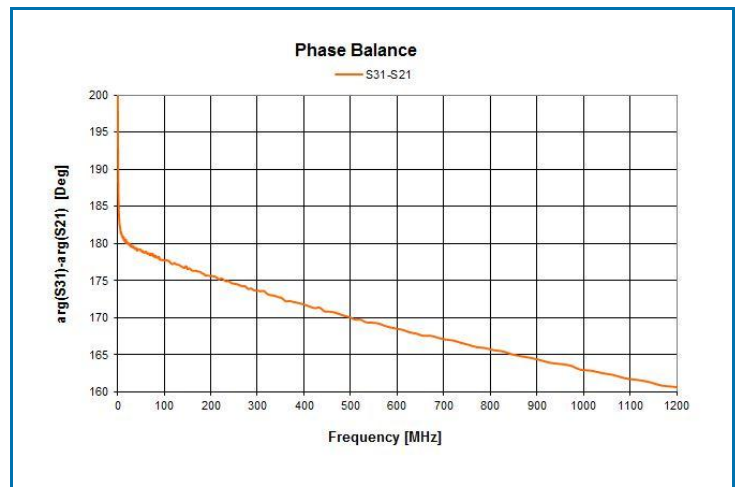
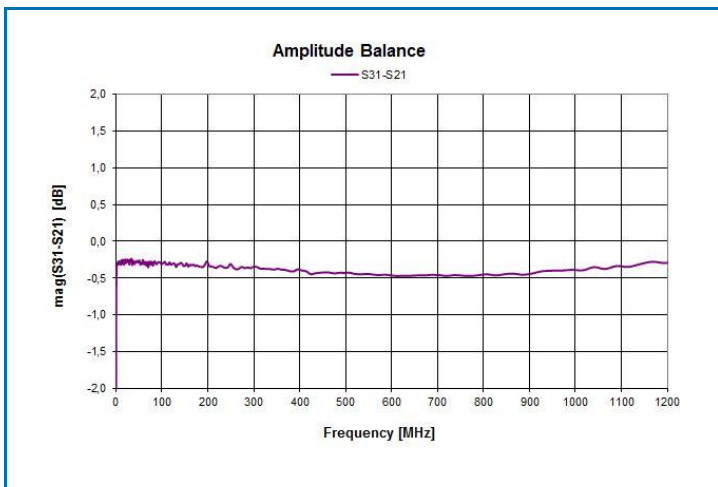
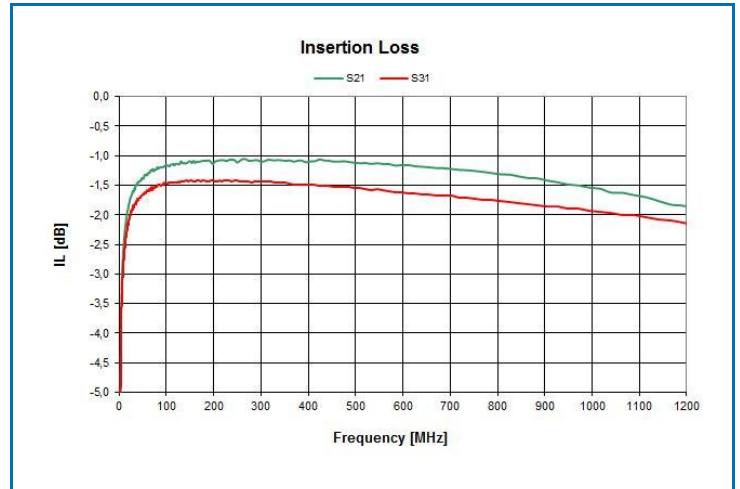
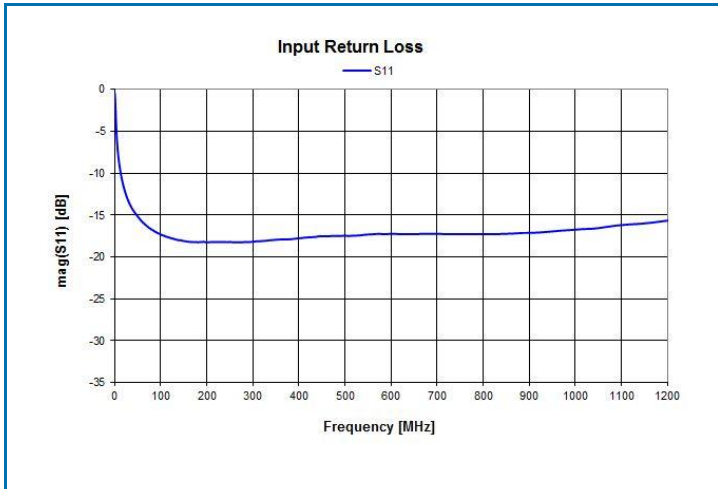

Package Outline, Pin Out and Branding Drawing (Dimensions in inches [millimeters])

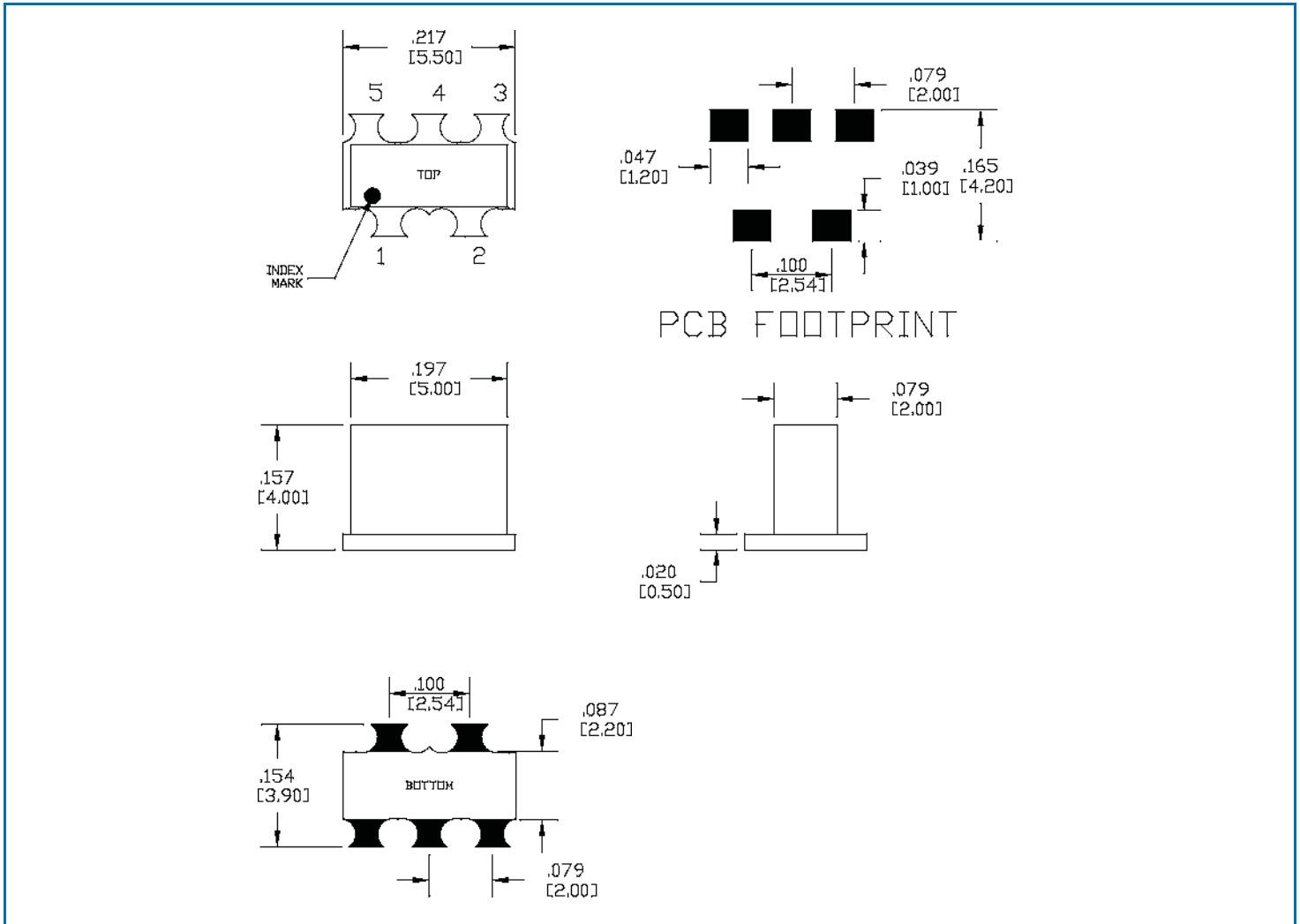

Pin Names and Descriptions

Pin	Name	Description
1	PRIMARY DOT	Input (Port 1)
2	PRIMARY	Ground
3	SECONDARY	Output (Port 3)
4	CENTER TAP	Ground
5	SECONDARY DOT	Output (Port 2)