

1		
Description	Material	Finish
Nut	Brass	Nickel
Washer	Brass	Nickel
Body	Brass	Nickel
Socket	Brass	Gold
Crimp Ring	Brass	Nickel
Insulation	Teflon	N/A
O Ring	SI Rubber	N/A

RECOMMENDED CABLE STRIPPING DIMENSIONS

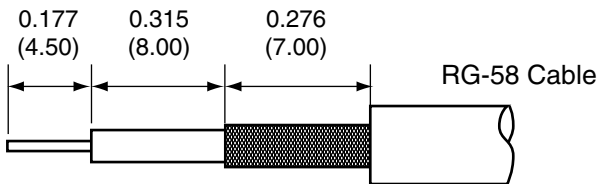

RECOMMENDED MOUNTING HOLE

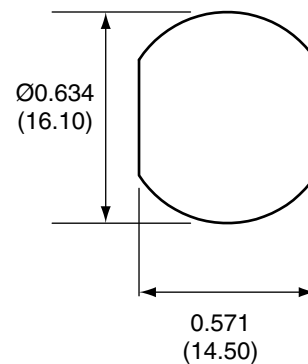

CRIMP RING

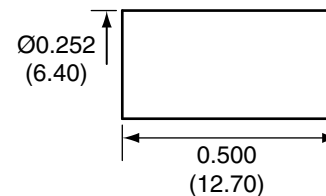

SIDE VIEW

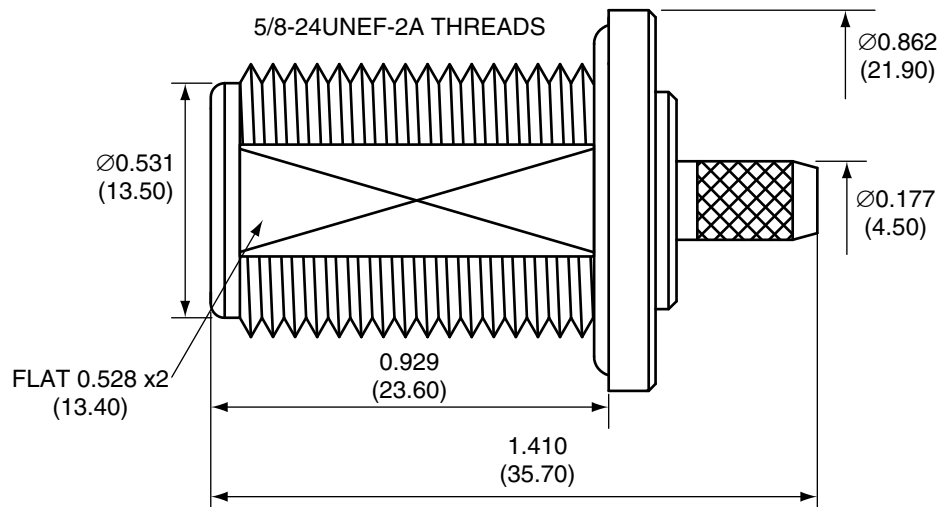

PIN

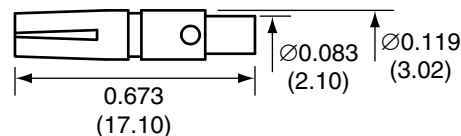

NUT

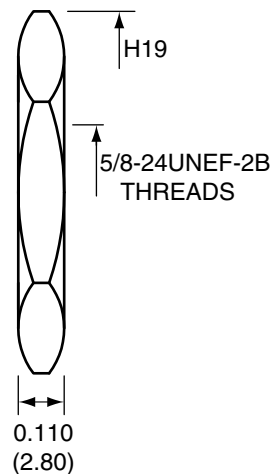

WASHER

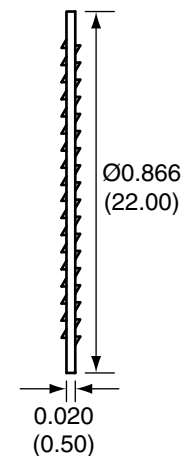

CONN005-R58 ASSEMBLY INSTRUCTIONS

1. Solder the socket to the center conductor.
2. Insert the socket, center conductor, and insulator into the body.
3. Wrap the braid around the tail of the body and crimp the ring with a hex crimp tool labeled for use with RG-58 cable.

Title N FEMALE BULKHEAD MOUNT
CABLE END CRIMP FOR RG58 CABLE

Part No. CONN005-R58 Revision: 1.0

Dimensions: INCHES (mm) Date: 2/11/2008

CONNECTOR CITY
159 ORT LANE
MERLIN, OR 97532
PH (541)-471-6256
FAX (541)-471-6251

Sheet 1 of 1

CONNECTOR CITY
THE VALUE OF CONNECTIONS