

Surface Mount Aluminum Electrolytic Capacitors NAWR Series

FEATURES

- CYLINDRICAL V-CHIP CONSTRUCTION FOR SURFACE MOUNTING
- LOW PROFILE 4.6MM HEIGHT
- LOAD LIFE (2,000 ~ 3,000 HOURS @ +105°C)
- DESIGNED FOR AUTOMATIC MOUNTING AND REFLOW SOLDERING

SAC Alloy Compatible
245°C

**RoHS
Compliant**
includes all homogeneous materials



CHARACTERISTICS

Rated Voltage Rating	6.3 ~ 50Vdc						
Rated Capacitance Range	0.47 ~ 100 μ F						
Operating Temp. Range	-40 ~ +105°C						
Capacitance Tolerance	\pm 20% (M)						
Max. Leakage Current After 2 Minutes @ 20°C	0.01CV or 3 μ A whichever is greater						
Dissipation Factor	W.V. (Vdc)	6.3	10	16	25	35	50
	S.V. (Vdc)	8.0	13	20	32	44	63
	Tan δ @ 120Hz/20°C	0.35	0.30	0.20	0.16	0.14	0.12
Low Temperature Stability Impedance Ratio @ 120Hz	W.V. (Vdc)	6.3	10	16	25	35	50
	Z-25°C/Z+20°C	4	3	2	2	2	2
	Z-40°C/Z+20°C	10	8	6	4	4	4
Load Life Test @ 105°C D \leq 5mm: 2,000 hours D = 6.3mm: 3,000 hours	Capacitance Change	Within \pm 30% of initial measured value					
	Tan δ	Less than \pm 300% of the specified maximum value					
	Leakage Current	Less than the specified maximum value					

*See Part Number System for Details

STANDARD VALUES AND CASE SIZES (mm)

Cap. (μ F)	Code	Working Voltage (Vdc)					
		6.3	10	16	25	35	50
0.47	R47	-	-	-	-	-	4X4.6
1.0	1R0	-	-	-	-	-	4X4.6
2.2	2R2	-	-	-	-	-	4X4.6
3.3	3R3	-	-	-	-	-	4X4.6
4.7	4R7	-	-	-	4X4.6	4X4.6	5X4.6
10	100	-	-	4X4.6	5X4.6	5X4.6	6.3X4.6
22	220	4X4.6	5X4.6	5X4.6	6.3X4.6	6.3X4.6	-
33	330	5X4.6	5X4.6	6.3X4.6	6.3X4.6	-	-
47	470	5X4.6	6.3X4.6	6.3X4.6	6.3X4.6	-	-
100	101	6.3X4.6	6.3X4.6	-	-	-	-

PART NUMBER SYSTEM

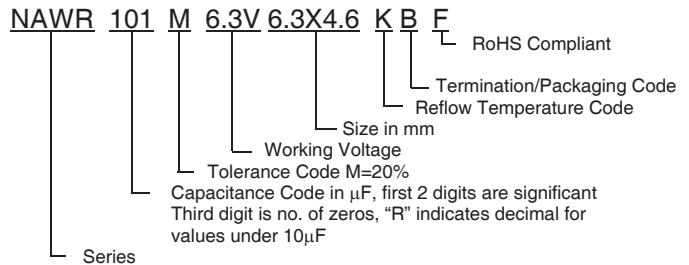

PEAK REFLOW TEMPERATURE CODES

Code	Peak Reflow Temperature
K	245°C

TERMINATION FINISH & PACKAGING OPTIONS CODES

Code	Finish & Reel Size
B	Sn-Bi Finish & 13" Reel

DIMENSIONS (mm) AND REEL QUANTITIES

Case Size	$\phi D \pm 0.5$	L max.	A ± 0.2	B ± 0.2	I ± 0.3	W	P ± 0.2	Qty/Reel
4X4.6	4.0	4.6	4.3	4.3	2.0	0.5 ~ 0.8	1.0	1,500
5X4.6	5.0	4.6	5.3	5.3	2.3	0.5 ~ 0.8	1.4	1,000
6.3X4.6	6.3	4.6	6.6	6.6	2.6	0.5 ~ 0.8	2.2	1,000

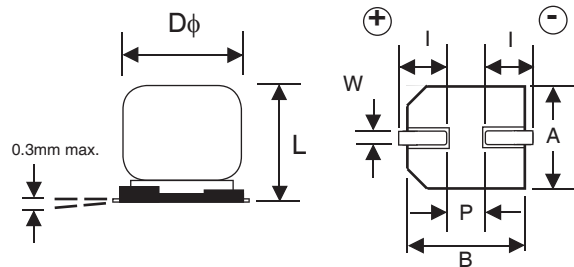

Surface Mount Aluminum Electrolytic Capacitors NAWR Series

STANDARD VALUES, CASE SIZES AND SPECIFICATIONS

NIC Part Number	Cap. (μF)	W.V. (Vdc)	Dissipation Factor (Tan δ)	Max. ESR (Ω) 120Hz, +20°C	Max. Ripple Current (mA) +105°C, 120Hz	Load Life Hours @ +105°C
NAWR220M6.3V4X4.6KBF	22	6.3	0.35	26.39	20	2000
NAWR330M6.3V5X4.6KBF	33		0.35	17.59	26	2000
NAWR470M6.3V5X4.6KBF	47		0.35	12.35	32	2000
NAWR101M6.3V6.3X4.6KBF	100	10	0.35	5.81	49	3000
NAWR220M10V5X4.6KBF	22		0.3	22.62	24	2000
NAWR330M10V5X4.6KBF	33		0.3	15.08	29	2000
NAWR470M10V6.3X4.6KBF	47		0.3	10.59	38	3000
NAWR101M10V6.3X4.6KBF	100	16	0.3	4.98	52	3000
NAWR100M16V4X4.6KBF	10		0.2	33.17	17	2000
NAWR220M16V5X4.6KBF	22		0.2	15.08	26	2000
NAWR330M16V6.3X4.6KBF	33		0.2	10.05	36	3000
NAWR470M16V6.3X4.6KBF	47	25	0.2	7.06	43	3000
NAWR4R7M25V4X4.6KBF	4.7		0.16	56.47	12	2000
NAWR100M25V5X4.6KBF	10		0.16	26.54	19	2000
NAWR220M25V6.3X4.6KBF	22		0.16	12.06	33	3000
NAWR330M25V6.3X4.6KBF	33	35	0.16	8.04	40	3000
NAWR470M25V6.3X4.6KBF	47		0.16	5.65	44	3000
NAWR4R7M35V4X4.6KBF	4.7		0.14	49.41	13	2000
NAWR100M35V5X4.6KBF	10		0.14	23.22	24	2000
NAWR220M35V6.3X4.6KBF	22	50	0.14	10.56	35	3000
NAWR47M50V4X4.6KBF	0.47		0.12	423.50	2.8	2000
NAWR1R0M50V4X4.6KBF	1		0.12	199.04	5.9	2000
NAWR2R2M50V4X4.6KBF	2.2		0.12	90.47	10	2000
NAWR3R3M50V4X4.6KBF	3.3	50	0.12	60.32	12	2000
NAWR4R7M50V5X4.6KBF	4.7		0.12	42.35	15	2000
NAWR100M50V6.3X4.6KBF	10		0.12	19.90	24	3000

RIPPLE CURRENT FREQUENCY CORRECTION FACTOR

Frequency	120Hz	1KHz	10KHz	100KHz ~
1.0 ~ 3.3μF	1.0	1.30	1.50	1.80
>4.7 ~ 33μF	1.0	1.20	1.30	1.45
>33μF	1.0	1.10	1.20	1.30

PEAK REFLOW TEMPERATURE, DURATION AND NUMBER OF REFLOW PASSES ALLOWED

Diameter	Peak Temperature	Duration	Time above 200°C	Time above 217°C	Time above 230°C	Number of Reflow Passes
4 ~ 6.3mm φ	+245°C	Time ≥ 240°C 5 sec.	60 sec.	50 sec.	30 sec.	2

RECOMMENDED LAND PATTERN DIMENSIONS (mm)

Case Size	a	b	c
4X4.6	1.0	2.6	1.8
5X4.6	1.4	3.0	1.8
6.3x4.6	1.8	3.6	1.8

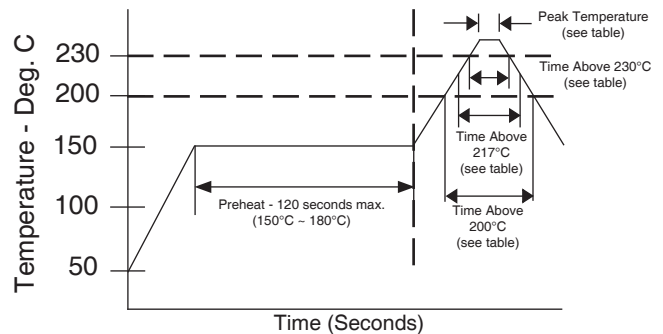
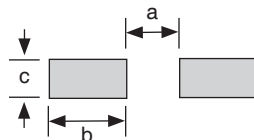

PRECAUTIONS

Please review the notes on correct use, safety and precautions found on pages T10 & T11 of NIC's Electrolytic Capacitor catalog. Also found at www.niccomp.com/precautions. If in doubt or uncertainty, please review your specific application - process details with NIC's technical support personnel: tpmg@niccomp.com



Surface Mount Aluminum Electrolytic Capacitors NAWR Series

CARRIER TAPE

Case Size	A ±0.2	B ±0.2	C ±0.3	D ±0.1	P ±0.1	T ±0.2
4X4.6	4.7	4.7	12.0	5.5	8.0	5.0
5X4.6	5.7	5.7	12.0	5.5	12.0	5.0
6.3X4.6	7.0	7.0	16.0	7.5	12.0	5.1

TR13 330mm (13") REEL

Case Size	W ±1.0	Quantity Per Reel
		13" Reel
4X4.6	14.0	1,500 pcs
5X4.6	14.0	1,000 pcs
6.3X4.6	18.0	1,000 pcs

TAPING SPECIFICATIONS (mm)

- Both Leader and Trailer tape: Minimum 10 empty pockets and 20cm of cover tape.
- Connection: Maximum 3 connections (slices) per reel.

CARRIER

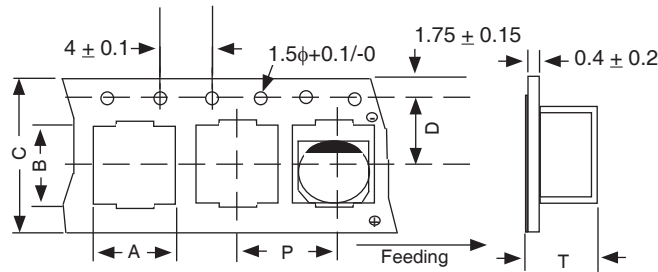

REEL

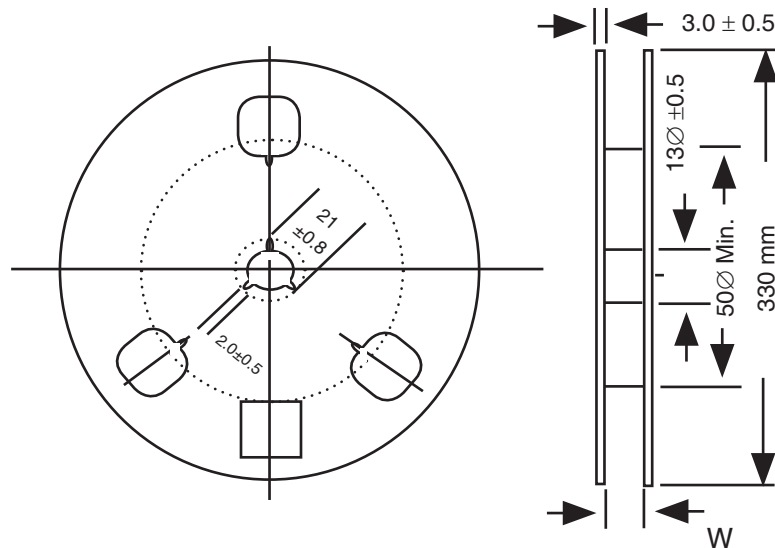

Review & Compare Reflow Soldering Heat Limits
V-chip SMT Aluminum Electrolytic Capacitors
www.niccomp.com/RS�

