

FEATURES

- Internally frequency compensated for unity gain
- Large DC voltage gain : 100dB
- Wide power supply range : 3V~32V(or±1.5V~16V)
- Input common-mode voltage range includes ground
- Large output voltage swing : 0V DC to $V_{CC}-1.5V$ DC
- Power drain suitable for battery operation
- Moisture Sensitivity Level 3
- LM358G is Halogen Free product

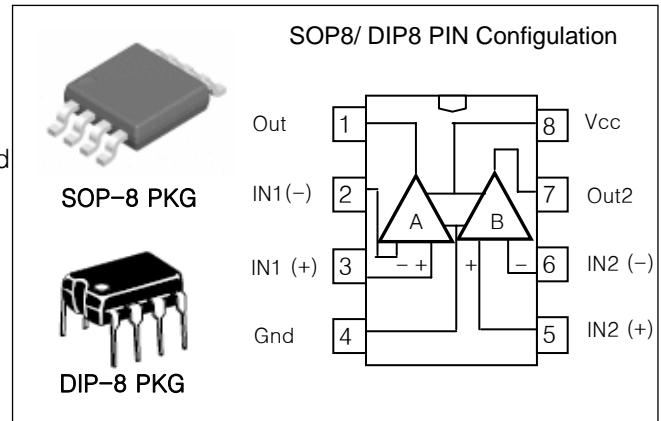

ORDERING INFORMATION

Device	Package
LM358D	8 SOP
LM358GD	
LM358N	8 DIP

DUAL OPERATIONAL AMPLIFIERS

LM358 consists of four independent, high gain, internally frequency compensated operational amplifiers which were designed specifically to operate from a single power supply over a wide range of voltage. Operation from split power supplies is also possible and the low power supply current drain is independent of the magnitude of the power supply voltage.

Application areas include transducer amplifier, DC gain blocks and all the conventional OP amp circuits which now can be easily implemented in single power supply systems.

EQUIVALENT CIRCUIT

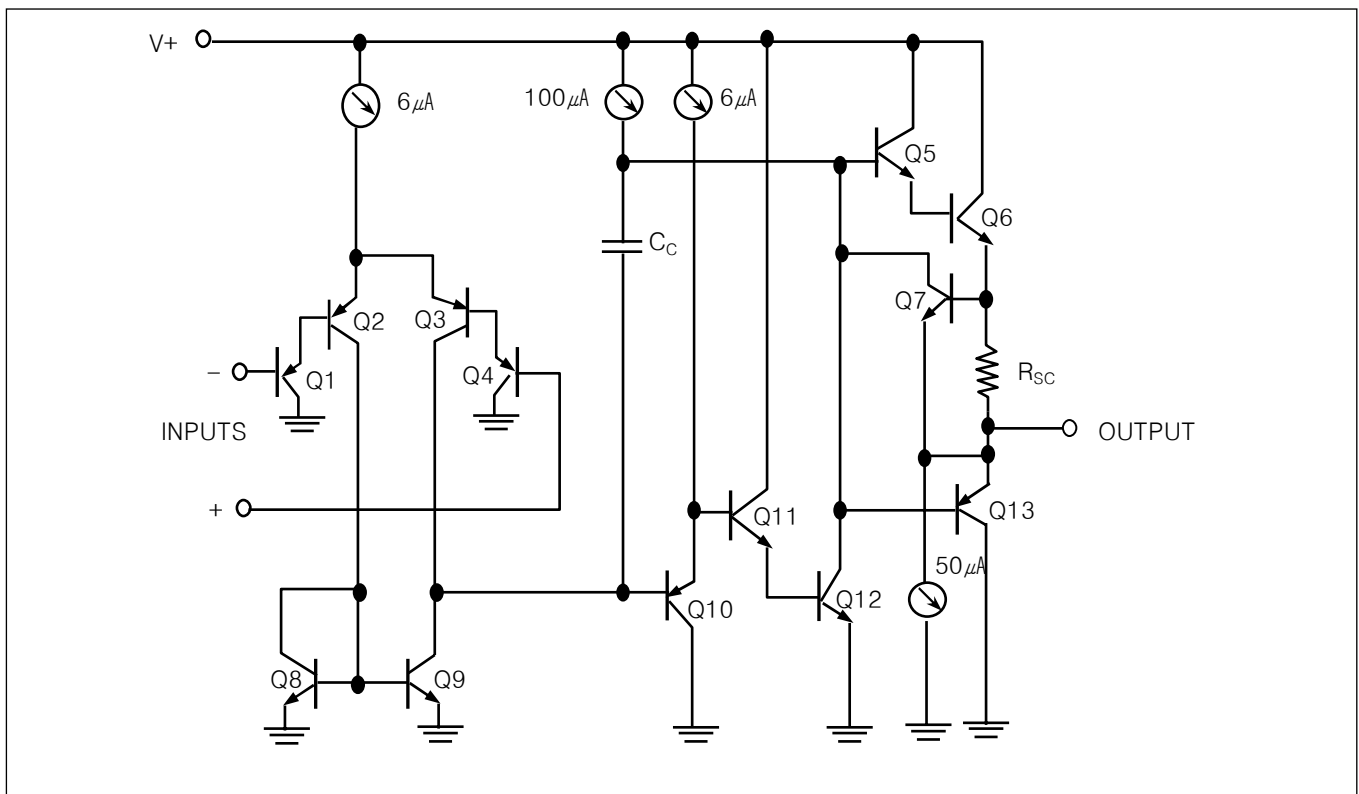

ABSOLUTE MAXIMUM RATINGS

CHARACTERISTIC	SYMBOL	VALUE	UNIT
Supply Voltage	V_{CC}	± 16 or 32	V
Differential Input Voltage	$V_{I(DIFF)}$	± 32	V
Input Voltage	V_I	-0.3 to +32	V
Output Short Circuit to GND $V_{CC} \leq V$ $T_A = 25^\circ\text{C}$ (One Amp)		Continuous	
Operating Temperature Range	T_{OPR}	0~+70	$^\circ\text{C}$
Storage Temperature Range	T_{STG}	-65 to +150	$^\circ\text{C}$

Electrical characteristics at specified free-air temperature, $V_{CC} = 5V$ (unless otherwise noted)

PARAMETER	TEST CONDITIONS*	LM358			UNIT
		MIN	TYP	MAX	
V_{IO} Input Offset Voltage	$V_{CC} = 5V$ to MAX, $V_{IC} = V_{ICR MIN}$, $V_O = 1.4V$	25 $^\circ\text{C}$	3	7	mV
		Full Range		9	
αV_{IO} Average Temperature Coefficient of Input Offset Voltage		Full Range	7		$\mu\text{V}/^\circ\text{C}$
I_{IO} Input Offset Current	$V_O = 1.4V$	25 $^\circ\text{C}$	2	50	nA
		Full Range		150	
αI_{IO} Average Temperature Coefficient of Input Offset Current		Full Range	10		pA/ $^\circ\text{C}$
I_{IB} Input Bias Current	$V_O = 1.4V$	25 $^\circ\text{C}$	-20	-250	nA
		Full Range		-500	
V_{ICR} Common-Mode Input Voltage Range	$V_{CC} = 5V$ to MAX	25 $^\circ\text{C}$	0 to $V_{CC} - 1.5$		V
		Full Range	0 to $V_{CC} - 2$		
V_{OH} High-Level Output Voltage	$R_L \geq 2k\Omega$	25 $^\circ\text{C}$	$V_{CC} - 1.5$		V
	$V_{CC} = \text{MAX}$, $R_L = 2k\Omega$	Full Range	26		
	$V_{CC} = \text{MAX}$, $R_L \geq 10k\Omega$	Full Range	27	28	
V_{OL} Low-Level Output Voltage	$R_L \geq 10k\Omega$	Full Range	5	20	mV
A_{VD} Large-Signal Differential Voltage Amplification	$V_{CC} = 15V$, $V_O = 1V$ to 11V, $R_L \geq 2k\Omega$	25 $^\circ\text{C}$	25	100	V/mV
		Full Range	15		
THD Total Harmonic Distortion	$f = 1\text{kHz}$, $A_v = 20\text{dB}$, $R_L = 2k\Omega$ $V_O = 2V_{pp}$, $C_L = 100\text{pF}$, $V_O = 2V_{pp}$	25 $^\circ\text{C}$		0.02	%
CMRR Common-Mode Rejection Ratio	$V_{CC} = 5V$ to MAX, $V_{IC} = V_{ICR MIN}$	25 $^\circ\text{C}$	65	80	dB
K_{SVR} Supply Voltage Rejection Ratio ($\Delta V_{CC} / \Delta V_{IO}$)	$V_{CC} = 5V$ to MAX	25 $^\circ\text{C}$	65	100	dB
V_{O1} / V_{O2} Crosstalk Attenuation	$f = 1\text{kHz}$ to 20kHz	25 $^\circ\text{C}$		120	dB
I_O Output Current	$V_{CC} = 15V$, $V_{ID} = 1V$, $V_O = 0$	25 $^\circ\text{C}$	-20	-30	mA
		Full Range	-10		
	$V_{CC} = 15V$, $V_{ID} = -1V$, $V_O = 15V$	25 $^\circ\text{C}$	10	20	μA
		Full Range	5		
I_{OS} Short-Circuit Output Current	V_{CC} at 5V, GND at -5V, $V_O = 0$	25 $^\circ\text{C}$	± 40	± 60	mA
I_{CC} Supply Current (Two Amplifiers)	$V_O = 2.5V$, No Load	Full Range	0.7	1.2	mA
	$V_{CC} = \text{MAX}$, $V_O = 0.5V_{CC}$, No Load	Full Range	1	2	

* All characteristics are measured under open-loop conditions with zero common-mode input voltage unless otherwise specified <<MAX>> V_{CC} for testing purpose is 30V. Full range is 0 $^\circ\text{C}$ to 70 $^\circ\text{C}$.

TYPICAL PERFORMANCE CHARACTERISTICS

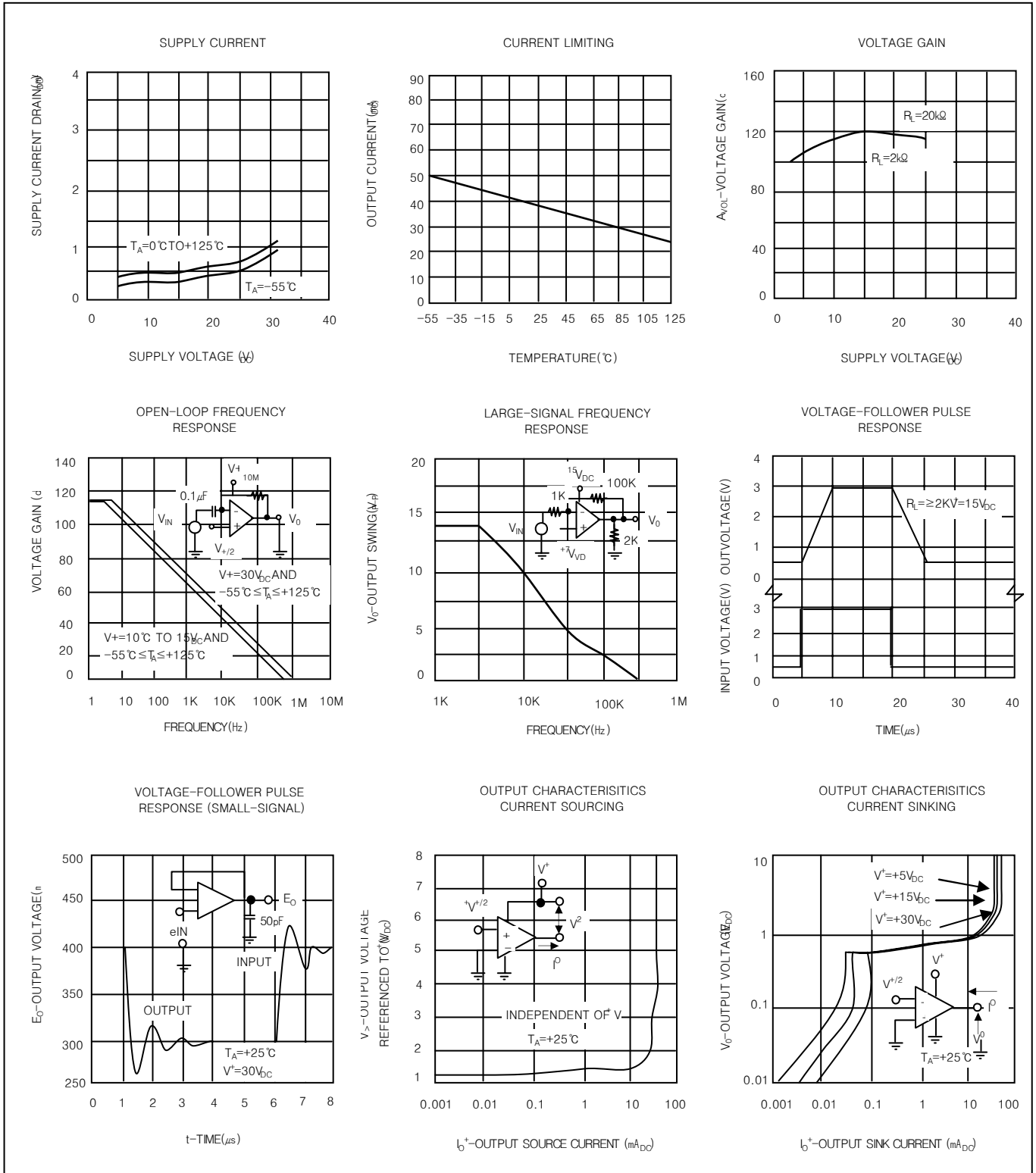

TYPICAL PERFORMANCE CHARACTERISTICS (CONTINUED)

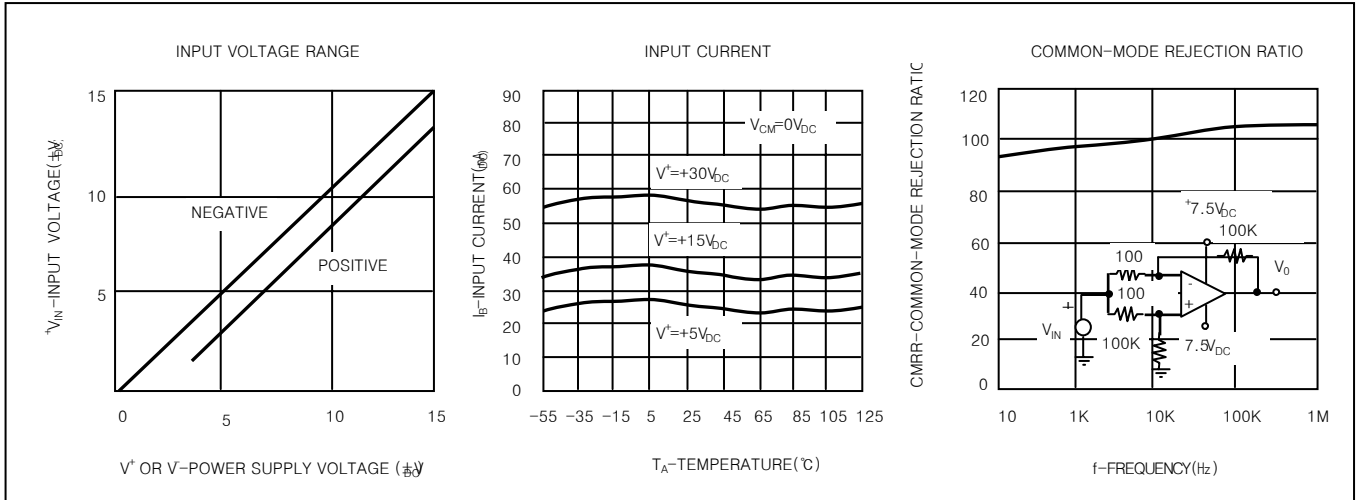

TYPICAL APPLICATIONS

