



Electronic ballast with PFC using L6574 and L6561

Introduction

Dedicated ICs for lamp ballast applications are now replacing the old solutions based on bipolar transistors driven by a saturable pulse transformer.

The L6574 is a high-performance ballast driver, designed using 600-V BCD offline technology, which ensures all the features needed to properly drive and control a fluorescent bulb. It is provided with built-in VCO start-up sequence circuitry, protections, and an operation amplifier for implementing a closed-loop control of the lamp current.

Contents

- 1 Half bridge converter for electronic lamp ballast 4**
 - 1.1 Lamp requirements 4
- 2 L6574 ballast driver 5**
- 3 Device block description 8**
 - 3.1 Preheating and ignition section 8
 - 3.2 Control section 12
 - 3.3 Bootstrap section 13
 - 3.3.1 C_{boot} selection and charging 13
- 4 Description of the demonstration application 15**
 - 4.1 Power factor section 17
 - 4.2 Ballast section 17
 - 4.3 Preheating and ignition sequence 18
 - 4.4 Current feedback loop 18
 - 4.5 Start-up and supply 19
 - 4.6 Safety circuitry 20
- 5 Design tips 21**
 - 5.1 Inductance and capacitor evaluation 21
- 6 Dimming the lamp 24**
 - 6.1 Dimming level and lamp turn-on 25
- 7 Revision history 26**

List of figures

Figure 1.	Half bridge topology	4
Figure 2.	Internal block diagram of the L6574	5
Figure 3.	Connection of a typical application	6
Figure 4.	Startup timing diagram and EN2 function	8
Figure 5.	Timing block	9
Figure 6.	Timing oscillator block	9
Figure 7.	Cpre voltage and frequency shifting	11
Figure 8.	Operating frequency at Cf = 470 pF	11
Figure 9.	Controls timing diagram	12
Figure 10.	Startup timing diagram and EN2 function	13
Figure 11.	External bootstrap diode connection	14
Figure 12.	L6574 integrated bootstrap diode connection.	14
Figure 13.	Demonstration application circuit	15
Figure 14.	PCB and components layouts	16
Figure 15.	Current feedback loop	19
Figure 16.	Cpre waveform (Ch1) and amplifier output (Ch2).	19
Figure 17.	Open load safety circuit	20
Figure 18.	Extra voltage safety circuit	20
Figure 19.	Simplified schematic of the lamp	21
Figure 20.	Preheating transfer function	22
Figure 21.	Operating transfer function	23
Figure 22.	Iterative process	23

1 Half bridge converter for electronic lamp ballast

Voltage-fed, series-resonant half-bridge inverters are currently used for fluorescent lamps (*Figure 1*). This topology facilitates operation in zero voltage switching (ZVS) resonant mode, dramatically reducing the transistor switching losses and the electromagnetic interference.

To design a cost-effective, compact and smart electronic lamp ballast, a dedicated IC could be used to drive directly the power MOSFETs of the half bridge. Such controllers require a high voltage capability for the high-side floating transistor driver.

Figure 1. Half bridge topology

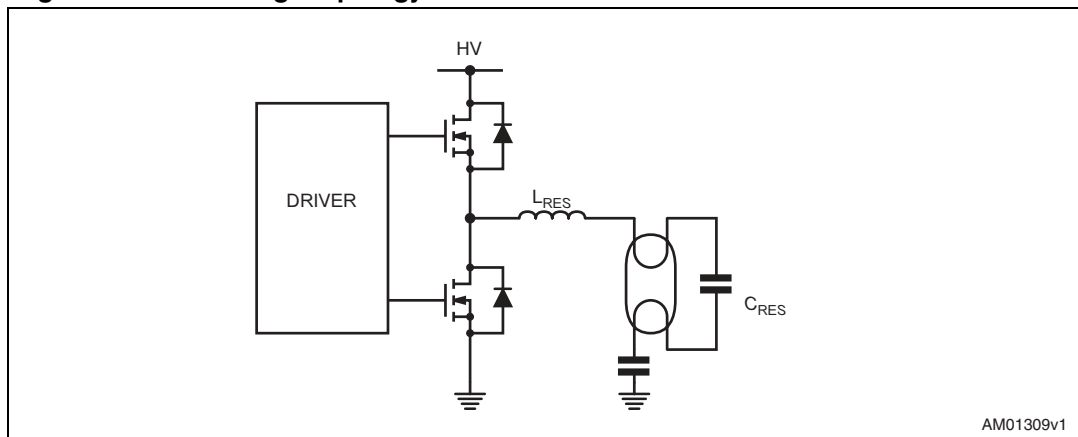

1.1 Lamp requirements

To prolong lamp life and to ensure efficient ignition of the lamp, the cathodes must be preheated. In fact, the preheating of the filaments allows an easy strike of the lamp, reducing the ignition voltage. During the preheating time, the lamp is characterized by a high impedance and the current flows only in the filaments. The resistance value of the filaments strictly depends on the type of lamp. Typically, these filaments present an initial low value (a few Ohms) that will increase by four to five times during the preheating phase.

After the preheating phase, the lamp must be ignited by increasing the voltage across it. The ignition voltage value also depends on the type of lamp, and it increases with the aging of the lamp. For a typical TL 58 W, the ignition voltage value is not much less than 1000 V. When a simple inverter with a constant switching frequency is used, external circuitry is also necessary (for example, a PTC or discrete timer). However, with ST's L6574 smart controller, both the preheating and ignition functions are achieved by using simple resistors and a capacitor, which set all the start-up procedures.

2 L6574 ballast driver

The L6574, whose internal block diagram is shown in [Figure 2](#), is an IC intended to drive two power MOSFETs or IGBTs in half-bridge topology, ensuring all the features needed to properly drive and control a fluorescent bulb. Moreover, by varying the switching frequency, it is possible to modulate the current in the lamp and as a consequence, the output power as well. The device is available in DIP16 and SO16N packages.

The L6574 has the following distinctive features.

- High voltage rail up to 600 V
- dV/dt immunity ± 50 V/ns in full temperature range
- Driver current capability (250 mA source and 450 mA sink)
- Switching times 80/40 ns rise fall with 1 nF load
- CMOS shutdown input
- Under-voltage lock-out
- Preheat and frequency shifting timing
- Sense operational amplifier for closed-loop control or protection features
- High-accuracy current-controlled oscillator
- Integrated bootstrap diode
- Clamping on VS
- SO16, DIP16 package.

Figure 2. Internal block diagram of the L6574

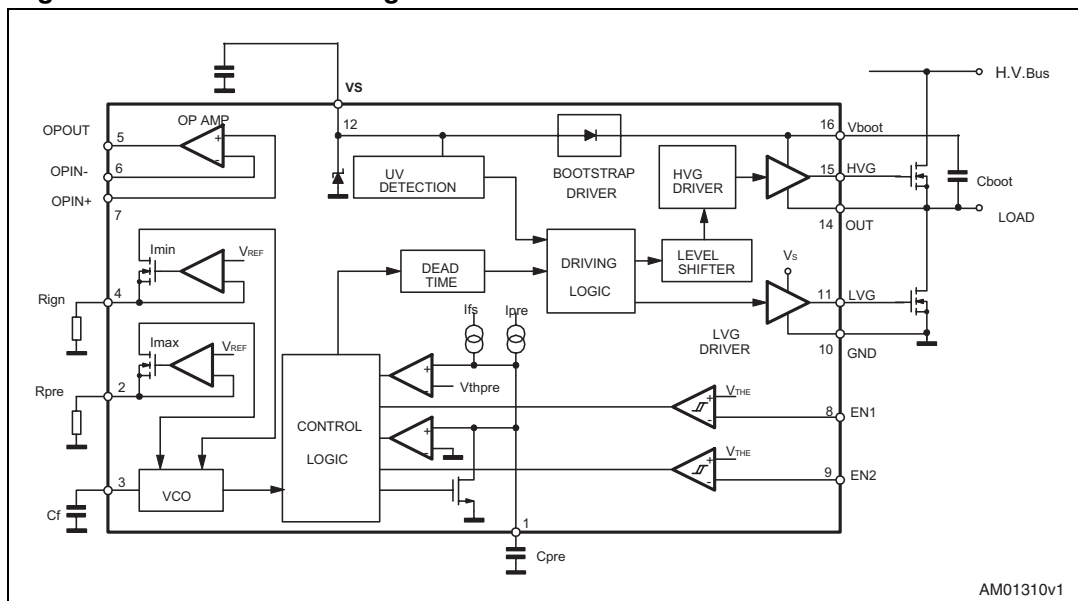
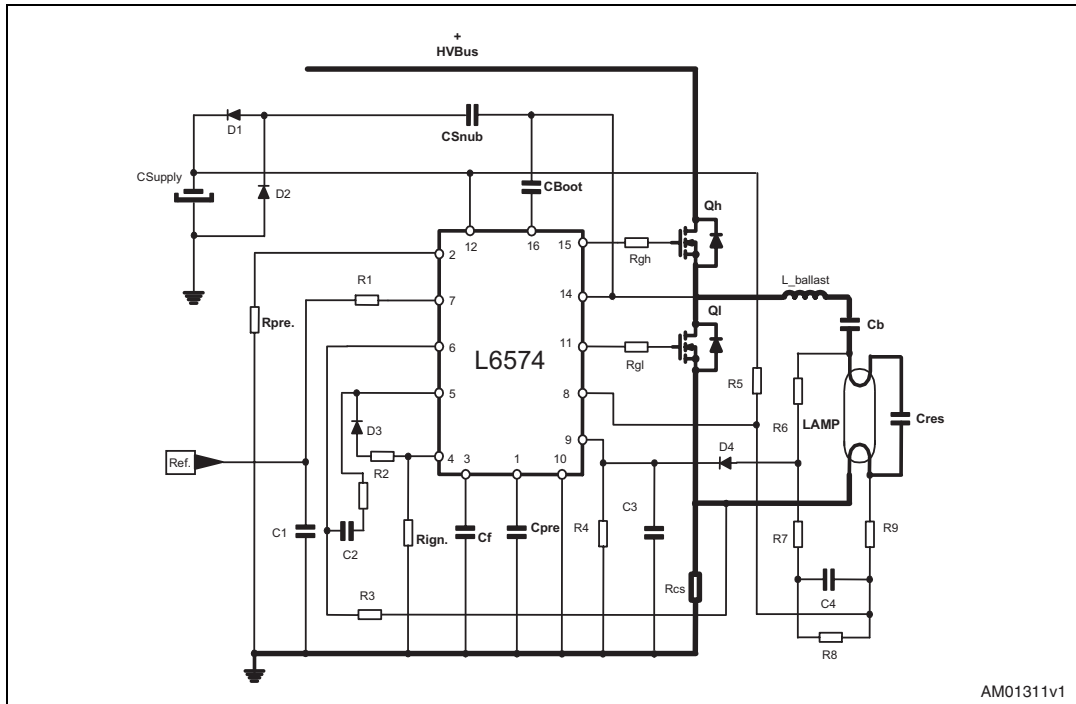

Figure 3. Connection of a typical application



AM01311v1

Table 1. Description of device pins

Number	Name	Function
1	C _{pre}	Preheat timing capacitor. The capacitor C _{pre} sets the preheating and the frequency shift time, according to the relations: $t_{pre} = K_{pre} \cdot C_{pre}$ and $t_{SH} = K_{FS} \cdot C_{pre}$ (typ. $K_{pre} = 1.5 \text{ s}/\mu\text{F}$, $K_{FS} = 0.15\text{s}/\mu\text{F}$). This feature is obtained by charging C _{pre} with two different currents. During t _{pre} , this current is independent of the external components, so C _{pre} is charged up to 3.5 V (preheat timing comparator threshold). During t _{SH} , the current depends on the value of R _{pre} (that is, on the difference between f _{pre} and f _{ign}). In this way t _{SH} is always set at 0.1t _{pre} . In steady state the voltage at pin 1 is 5 V (see Figure 5).
2	R _{pre}	Maximum oscillation frequency setting. The resistance connected between this pin and ground sets the f _{pre} value, fixing the difference between f _{pre} and f _{ign} (f _{pre} > f _{ign}). At the end of the start-up procedure, the effect current drawn from R _{pre} is over. The voltage at this pin is fixed at V _{REF} = 2 V.
3	CF	Oscillator frequency setting. The capacitor C _F , along with to R _{pre} and R _{ign} , sets f _{pre} and f _{IGN} . In normal operation this pin shows a triangular wave.
4	R _{ign}	Minimum oscillation frequency setting. The resistance connected between this pin and ground sets the f _{ign} value. The voltage at this pin is fixed at V _{REF} = 2 V.
5	OPout	Out of the operational amplifier. To implement a feedback control loop this pin can be connected to the R _{ign} pin by means of appropriate circuitry.
6	OPin-	Inverting input of the operational amplifier.
7	OPin+	Non-inverting Input of the operational amplifier.

Table 1. Description of device pins (continued)

Number	Name	Function
8	EN1	Enable 1. This pin (active high), forces the device into a latched shutdown state (like in undervoltage conditions). There are two ways of resuming normal operation: the first is by reducing the supply voltage below the undervoltage threshold and then increasing it again until the valid supply is recognized; the second is by activating the EN2 input (see Figure 9). The Enable 1 is specifically designed for strong faults (for example, in case of lamp disconnection).
9	EN2	Enable 2. EN2 input (active high) restarts the start-up procedure (preheating and ignition sequence). This feature is useful if the lamp does not turn on after the first ignition sequence (see Figure 10).
10	GND	Ground.
11	LVG	Low-side driver output. This pin must be connected to the low-side power MOSFET gate of the half bridge. A resistor connected between this pin and the power MOSFET gate can be used to reduce the peak current.
12	VS	Supply voltage. This pin is connected to the supply filter capacitor (15.6 V typical).
13	N.C.	Not connected. This pin sets a distance between the pins related to the high-voltage side and those related to the low-voltage side.
14	OUT	High-side driver floating reference. This pin must be connected close to the source of the high-side power MOSFET or IGBT.
15	HVG	High-side driver output. This pin must be connected to the high-side power MOSFET gate of the half bridge. A resistor connected between this pin and the power MOSFET gate can be used to reduce the peak current.
16	VBOOT	Bootstrapped supply voltage. The bootstrap capacitor must be connected between this pin and OUT. A patented integrated circuit replaces the external bootstrap diode by means of a high-voltage DMOS, synchronously driven with the low-side power MOSFET.

3 Device block description

The preheating control section and the bootstrap section are tightly linked to the application's design. This chapter describes their workings and usage.

3.1 Preheating and ignition section

The L6574's turn-on sequence is divided into three phases: the preheating phase, the ignition phase and the normal operation phase (Figure 4). The preheating phase is characterized by the highest oscillation frequency (f_{max}) for a period T_{pre} . During the ignition phase, the frequency shifts from f_{max} to f_{min} (which is the normal operating frequency) in a period T_{sh} .

Figure 4. Startup timing diagram and EN2 function

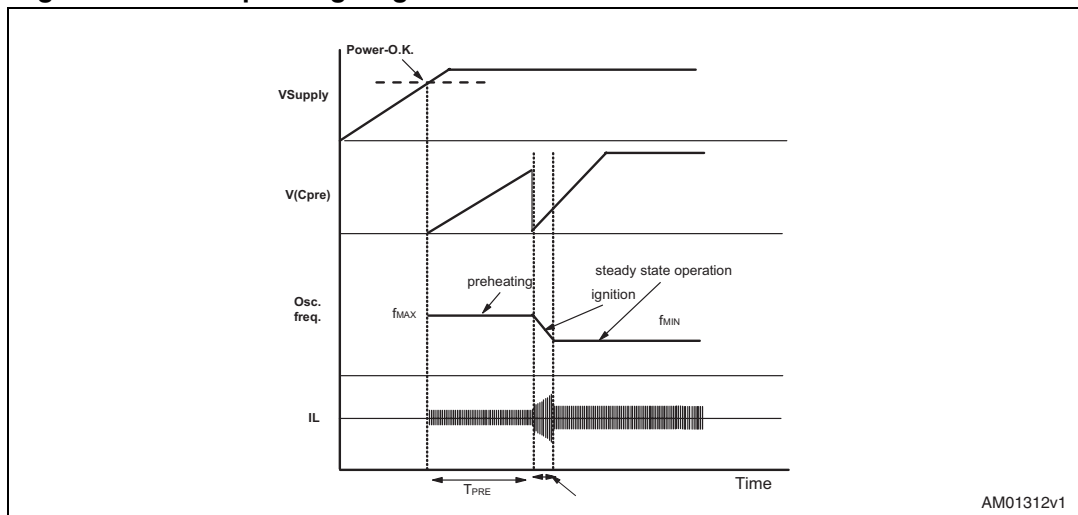

- $T_{pre} = K \cdot C_{pre}$
- $T_{IGN} = 0.1 \cdot T_{pre}$

All the above-mentioned parameters are set by carefully selecting a few external components. T_{pre} and T_{sh} are set by means of the capacitor C_{pre} that is connected to pin 1.

During the preheating phase (T_{pre}) the capacitor C_{pre} is charged by means of a constant current I_{pre} , which is generated internally and does not depend on any external components. The voltage across C_{pre} increases linearly up to the "preheating threshold" at which the preheating phase terminates.

Equation 1

$$T_{pre} = C_{pre} \cdot \frac{V_{th}}{I_{pre}}, \text{ where } V_{th} = 3.5V \text{ and } I_{pre} = 2.3\mu A$$

That is to say:

Equation 2

$$T_{pre} = 1.5s/\mu F \cdot C_{pre}$$

Figure 5. Timing block

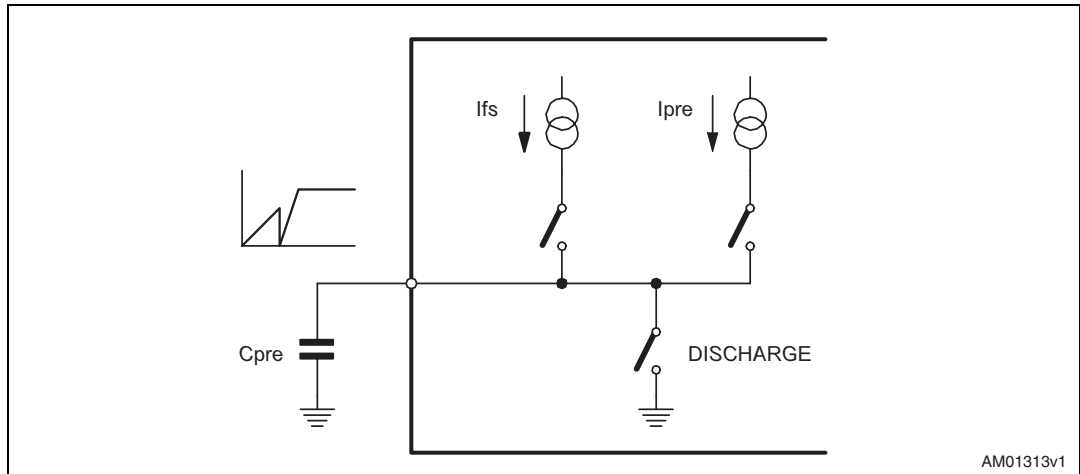

AM01313v1

Figure 6. Timing oscillator block

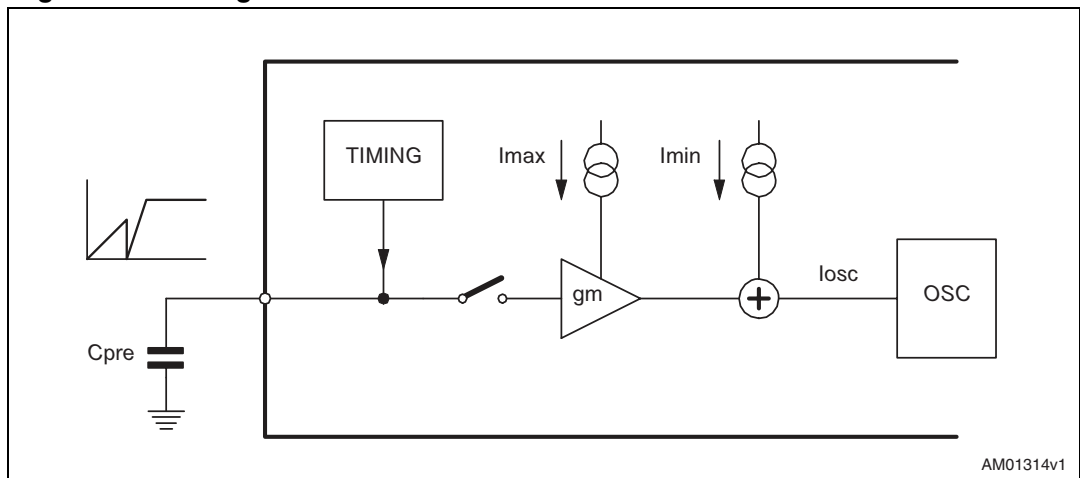

AM01314v1

After the preheating time, the capacitor C_{pre} is first quickly discharged and then recharged by the current I_{fs} , generating a second voltage ramp which feeds a transconductance amplifier, as shown in [Figure 6](#) (the switch is closed). Thus, this voltage signal is converted into a growing current which is subtracted from I_{max} to produce the frequency shifting from f_{max} to f_{min} . The current that drives the oscillator to set the frequency during this shifting is equal to:

Equation 3

$$I_{osc} = I_{min} + (I_{max} - g_m V_{Cpre}(t - T_{pre})) = I_{min} + \left(I_{max} - \frac{g_m I_{fs}}{C_{pre}}(t - T_{pre}) \right)$$

Where:

Equation 4

$$I_{\min} = \frac{V_{\text{REF}}}{R_{\text{ign}}}, I_{\max} = \frac{V_{\text{REF}}}{R_{\text{pre}}}, V_{\text{REF}} = 2\text{V}$$

R_{ign} and R_{pre} are the resistors connected to pin 4 and pin 2.

At the end of the preheating time ($t = T_{\text{pre}}$), the L6574 oscillates at f_{\max} , set by:

Equation 5

$$I_{\text{osc}}(T_{\text{pre}}) = I_{\text{osc}0} = I_{\min} = I_{\max} = V_{\text{REF}} \left(\frac{1}{R_{\text{ign}}} + \frac{1}{R_{\text{pre}}} \right)$$

This means that the preheating frequency depends on both R_{pre} and R_{ign} .

At the end of the frequency shifting ($t = T_{\text{pre}} + T_{\text{sh}}$), the second term of [Equation 3](#) decreases to zero and the switching frequency is set only by I_{\min} (that is, R_{ign}).

Equation 6

$$I_{\text{osc}}(T_{\text{sh}}) = I_{\min} = \frac{V_{\text{REF}}}{R_{\text{ign}}}$$

Since the second term of [Equation 3](#) is equal to zero, we have:

Equation 7

$$I_{\max} - \frac{g_m I_{\text{fs}} T_{\text{sh}}}{C_{\text{pre}}} = 0 \rightarrow T_{\text{sh}} = \frac{C_{\text{pre}} I_{\max}}{g_m I_{\text{fs}}}$$

Note that there is no fixed voltage threshold across C_{pre} in which the ignition phase finishes (that is, the end of the frequency shifting): T_{sh} depends on C_{pre} , I_{\max} , g_m , and I_{fs} ([Equation 7](#)). This fact is also verified in [Figure 7](#). By making T_{sh} independent of I_{\max} , the I_{fs} current has been designed to be a fraction of I_{\max} , therefore:

Equation 8

$$I_{\text{fs}} = \frac{I_{\max}}{K} \rightarrow T_{\text{sh}} = \frac{C_{\text{pre}} I_{\max}}{g_m I_{\max} K} \rightarrow T_{\text{sh}} = \frac{C_{\text{pre}}}{g_m K} \rightarrow T_{\text{sh}} = k_{\text{fs}} C_{\text{pre}}$$

In this way, the frequency shifting time depends only on the capacitor C_{pre} . The typical value of the k_{fs} constant (frequency shift timing constant) is 0.15 s/ μF , that is:

Equation 9

$$k_{\text{fs}} = k_{\text{pre}}/10$$

So when choosing C_{pre} , both T_{pre} and T_{sh} are set.

The frequencies f_{\min} and f_{\max} depend on the resistors R_{pre} and R_{ign} , but also on the capacitor C_f (oscillator frequency setting -> capacitor at pin 3). f_{\min} is set by choosing C_f and R_{ign} , then with R_{pre} the $\Delta f = f_{\max} - f_{\min}$ is set.

Simplified equations can be used.

Equation 10

$$f_{\min} = \frac{1.41}{R_{\text{ign}} \cdot C_f}$$

Equation 11

$$f_{\max} = \frac{1.41 \cdot (R_{\text{pre}} + R_{\text{ign}})}{R_{\text{pre}} \cdot R_{\text{ign}} \cdot C_f}$$

These equations fit well with the measured values, especially in the frequency range of 30 to 100 kHz. *Figure 8* shows a comparison between the measured and computed data of f_{\min} (at $C_f = 470$ pF).

Figure 7. C_{pre} voltage and frequency shifting

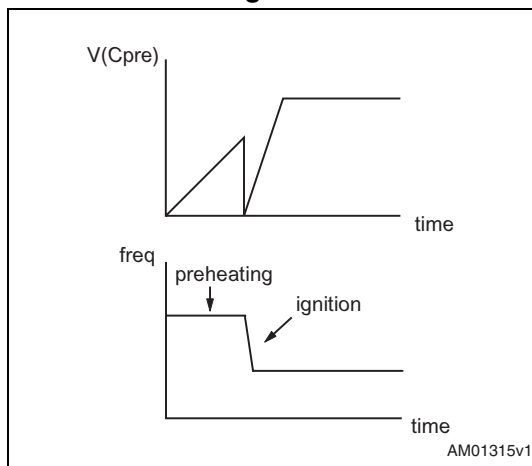
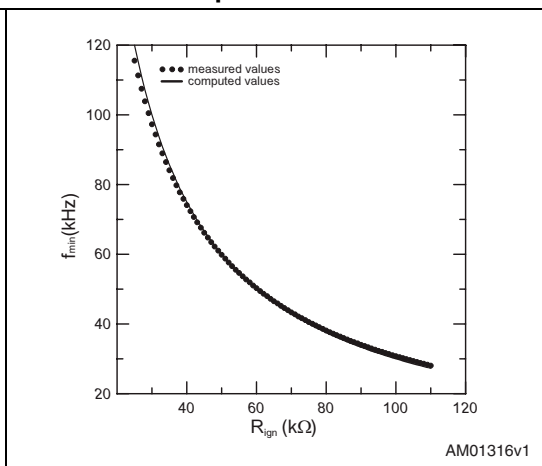

Figure 8. Operating frequency at $C_f = 470$ pF



To summarize:

Table 2. Parameter dependencies

Parameter	Set by choosing...
T_{pre}	C_{pre}
T_{sh}	C_{pre}
$\Delta f = f_{\max} - f_{\min}$	R_{pre}
f_{\min}	R_{ign} and C_f

If R_{pre} is not connected at pin 2, there is no Δf , so f_{\max} and f_{\min} have the same value. Furthermore, there is no I_{max} , that is to say there is no I_{fs} current. In this case, C_{pre} is charged only once by $I_{\text{pre}} = 2.3 \mu\text{A}$ up to 3.5 V (*Figure 7* shows the first voltage rise only). When C_{pre} is discharged, no I_{fs} current is present to recharge it. If R_{pre} is connected after the preheating and ignition phases, pin 1 (C_{pre}) is at 4.8 to 5 V with a current capability of a few μA ($1/6 I_{R_{\text{pre}}}$). If R_{pre} is not connected, C_{pre} is at GND level in the normal operation phase.

3.2 Control section

The L6574 has two control functions, EN1 and EN2. Both functions are active high. To fully understand how these functions work, refer to *Figure 9* and *Figure 10*.

- EN1 (latched enable) is dedicated to stopping all device functions and is usually activated when a strong fault is detected (for example, when the lamp is disconnected). This status can be cancelled in two different ways: either by reducing the supply voltage below its minimum threshold, or by activating the second control pin EN2 (EN2 overrides EN1). When the device restarts, the start-up sequence is reactivated.
- EN2 (repeating startup) is dedicated to restarting the preheating and ignition procedure; it is normally activated when the application fails to ignite the lamp. When EN2 is activated the starting procedure restarts. The L6574 operates to the maximum frequency all the while that EN2 remains active.

Figure 9. Controls timing diagram

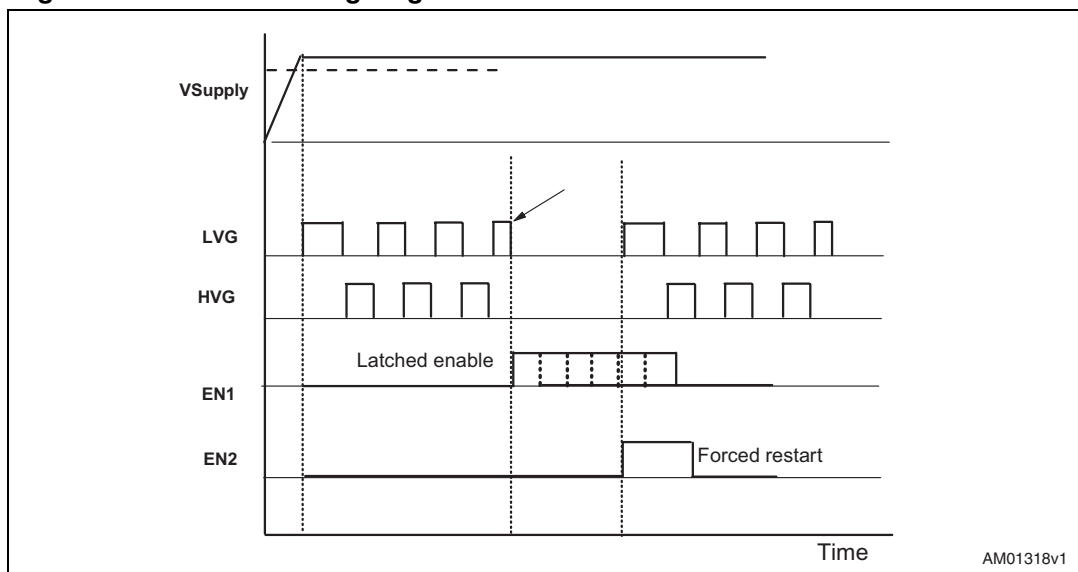
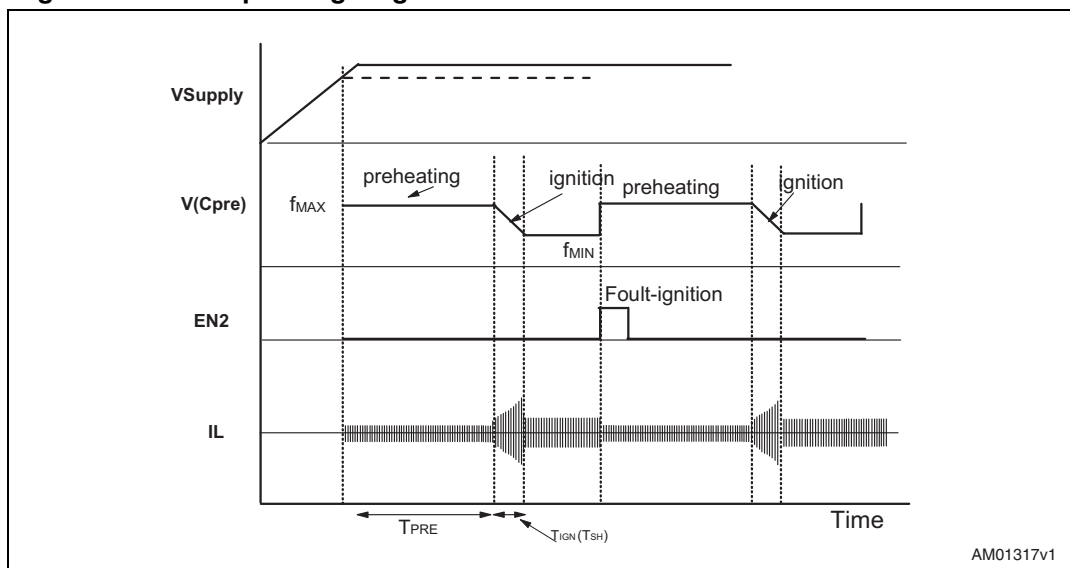

Figure 10. Startup timing diagram and EN2 function



AM01317v1

3.3 Bootstrap section

Bootstrap circuitry is needed to supply the high-voltage section. This function is normally accomplished by a high-voltage fast-recovery diode ([Figure 11](#)). In the L6574, a patented integrated structure replaces the external diode. It is realized by means of a high-voltage DMOS, driven synchronously with the low-side driver (LVG), with a diode connected in series, as shown in [Figure 12](#). An internal charge pump ([Figure 12](#)) provides the DMOS driving voltage.

The diode connected in series to the DMOS has been added to avoid it being unintentionally turned on.

3.3.1 C_{boot} selection and charging

To choose the proper C_{boot} value, the external MOS can be seen as an equivalent capacitor. This capacitor C_{ext} is related to the total gate charge of the MOS.

Equation 12

$$C_{\text{ext}} = \frac{Q_{\text{gate}}}{V_{\text{gate}}}$$

The ratio between the capacitors C_{ext} and C_{boot} is proportional to the cyclical voltage loss. It has to be:

Equation 13

$$C_{\text{boot}} \gg C_{\text{ext}}$$

For example, if Q_{gate} is 30 nC and V_{gate} is 10 V, C_{ext} is 3 nF. With C_{boot} = 100 nF, the drop would be 300 mV.

If the HVG needs to be supplied for a long period of time, the C_{boot} selection also has to take into account the leakage losses.

The internal bootstrap driver has great advantages: the external fast-recovery diode can be avoided (it usually has great leakage current). This structure can only work if V_{out} is close to GND (or lower) and if in the meanwhile the LVG is on. The charging time (T_{charge}) of the C_{boot} is the time in which both conditions are fulfilled and it has to be long enough to charge the capacitor.

The bootstrap driver introduces a voltage drop due to the DMOS $R_{DS(on)}$ (typical value at 25°C is 150 Ω). At low frequencies, this drop can be neglected, but must be taken into account when the frequency is increased.

The following equation is useful to compute the drop on the bootstrap DMOS.

Equation 14

$$V_{drop} = I_{charge} R_{DS(on)} \rightarrow V_{drop} = \frac{Q_{gate}}{T_{charge}} R_{DS(on)}$$

where Q_{gate} is the gate charge of the external power MOSFET, $R_{DS(on)}$ is the *on* resistance of the bootstrap DMOS, and T_{charge} is the charging time of the bootstrap capacitor.

For example: using a power MOSFET with a total gate charge of 30 nC, the drop on the bootstrap DMOS is about 1 V if the T_{charge} is 5 μs. In fact:

Equation 15

$$V_{drop} = \frac{30nC}{5\mu s} \cdot 150\Omega \sim 0.9V$$

V_{drop} has to be taken into account when the voltage drop on C_{boot} is calculated: if this drop is too high or if the charging time is insufficient, an external diode can be used.

Figure 11. External bootstrap diode connection

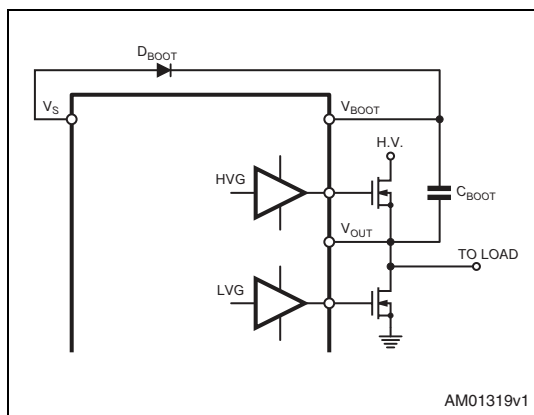
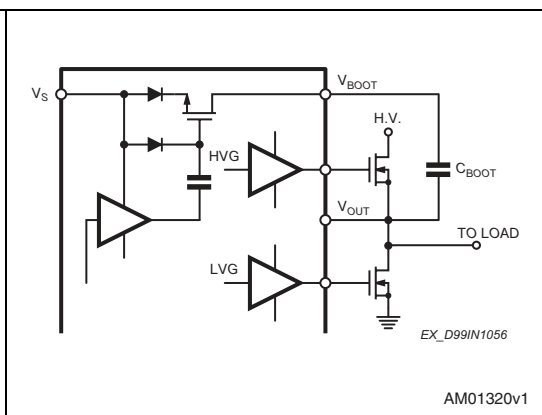

Figure 12. L6574 integrated bootstrap diode connection



4 Description of the demonstration application

The design has been developed to drive a TL fluorescent lamp up to 58 W. It is composed of two sections: the PFC, using the L6561 controller, and the ballast, based on the L6574 (see [Figure 13](#) and [Figure 14](#)). The application is provided with a current feedback that can be used to control the power (and, if necessary, the dimming function) by varying the switching frequency during normal burning of the lamp. The application is also provided with a safety circuitry that gets activated when an open load or faulty ignition of the lamp is detected.

Figure 13. Demonstration application circuit

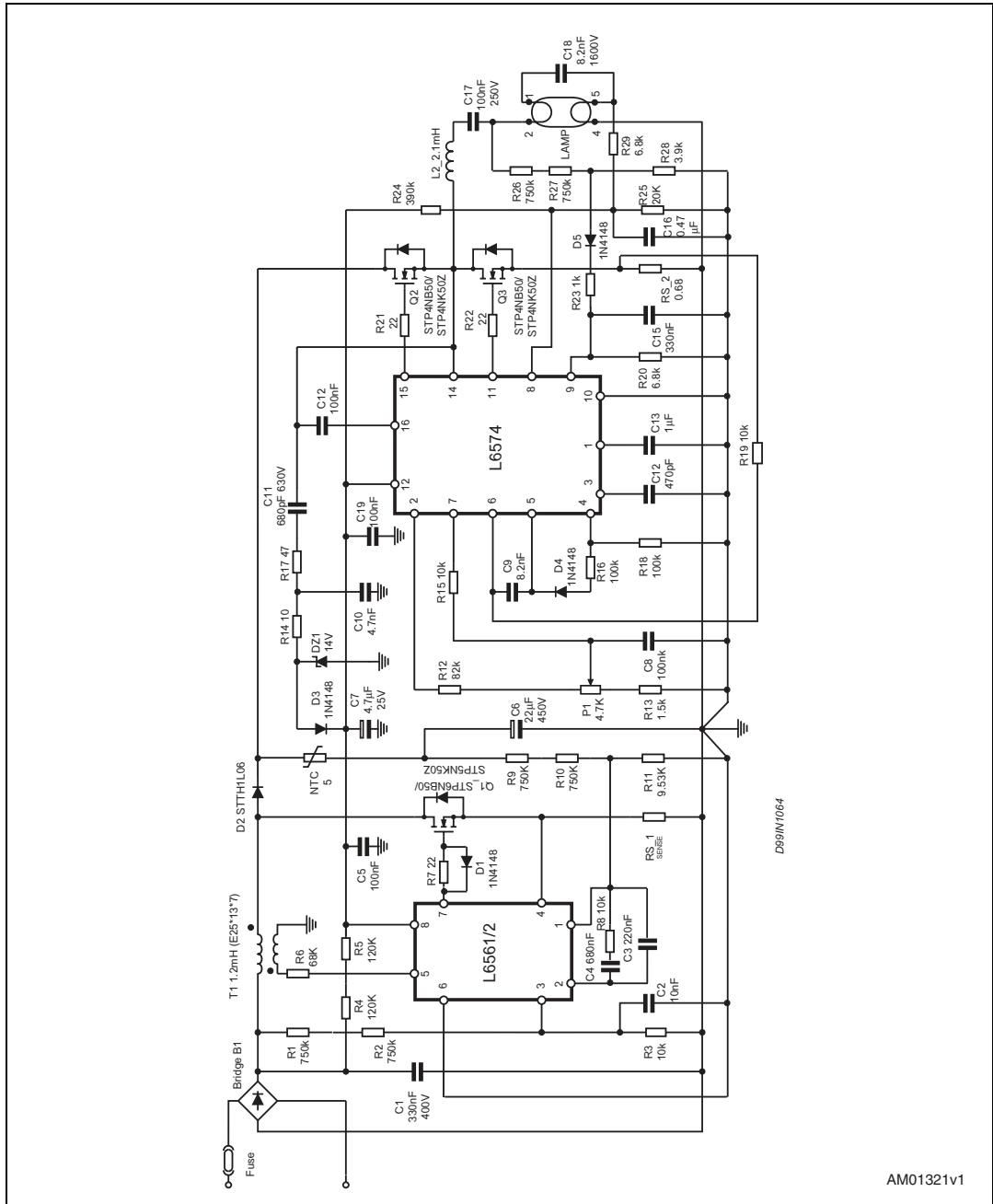
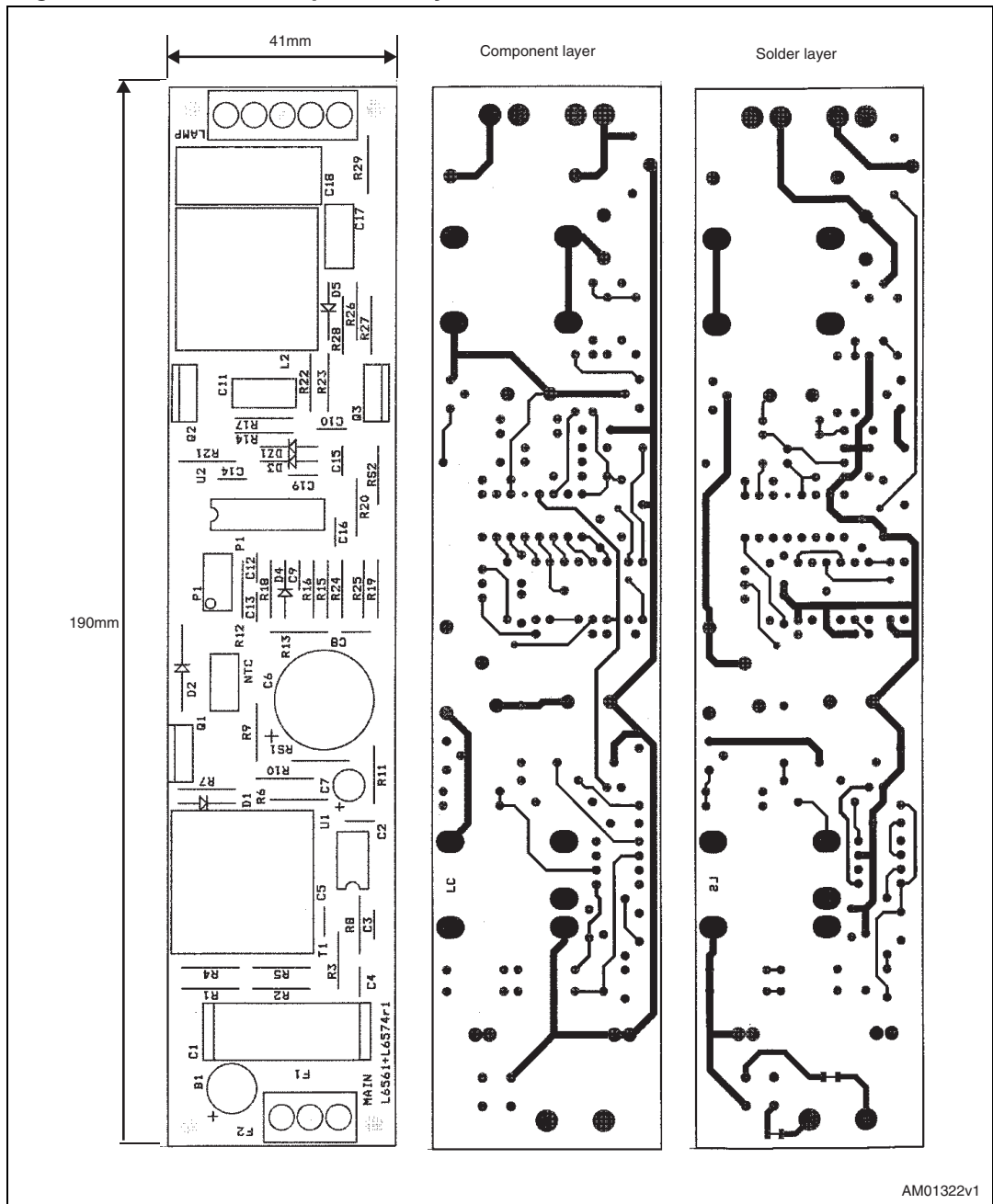

Figure 14. PCB and components layouts



AM01322v1

4.1 Power factor section

Even if the PFC stage is not strictly necessary for electronic ballast applications, in this design it has been introduced for the following reasons.

The PFC stage is necessary if the ballast input power is higher than 25 W. This provides many benefits.

The front-end stage of conventional off-line converters, typically made up of a full wave rectifier bridge with a capacitor filter, gets an unregulated DC bus from the AC mains. Therefore, the instantaneous line voltage will be below the voltage on the capacitor most of the time, which means that the rectifiers will only conduct for a small portion of each line's half-cycle. The current drawn from the mains will then be a series of narrow pulses whose amplitude will be 5-10 times higher than the resulting DC value.

Lots of drawbacks result from this: much higher peak and RMS current drawn from the line, distortion of the AC line voltage, overcurrents in the neutral line of the 3-phase systems, all contributing to a poor utilization of the power system's energy capability.

This energy capability can be measured in terms of either total harmonic distortion (THD), as norms provides for, or power factor (PF), intended as the ratio between the real power (the one transferred to the output) and the apparent power (RMS line voltage times RMS line current) drawn from the mains, which is more immediate. A traditional input stage with a capacitive filter has a low PF (0.5-0.7) and a high THD (> 10%).

The new European norms and the international standard requirements have spurred the design of high-power factor ballasts and are starting to impose a limit on the input current harmonic content. For these reasons, power factor correctors (PFC) are now being widely diffused in consumer and industrial lighting. With a high power factor switching pre-regulator, interposed between the input rectifier bridge and the bulk filter capacitor, the power factor is improved (by up to 0.99). The current capability is increased, while the bulk capacitor peak current and the harmonic disturbances are reduced.

The L6561/2 is an IC intended to control PFC pre-regulators by using the transition mode technique and is optimized for lamp ballast applications.

The operation is summarized below (for more information, see AN966). The AC mains voltage, that can range from 85 V to 265 V, is rectified by a diode bridge and delivered to the boost converter.

The boost converter consists of a boost inductor (T1), a controlled power switch (Q1), a catch diode (D2), an output capacitor (C6) and, obviously, control circuitry (see [Figure 3](#)).

The PFC section has been designed to supply a 400 V DC and a power of 60 W.

4.2 Ballast section

The regulated voltage is delivered to the ballast section. The ballast is based on the high-performance L6574, an offline half bridge driver designed using 600-V BCD technology. It adds to the fully-integrated half-bridge driver topology a built-in voltage controlled oscillator (VCO), a preheating start-up procedure and an operational amplifier dedicated to the feedback loop. To avoid cross-conduction of the power MOSFETs or IGBTs, the internal logic ensures a minimum dead time.

The load consists of a series resonant circuit (L2-C18) with the lamp connected across the capacitor (C18). This topology allows operation in zero voltage switching mode, to reduce the transistor switching losses and the electromagnetic interference generated by the output wiring of the lamp.

The blocking capacitor (C17) allows a zero average lamp current. In steady state the voltage across these capacitors is as high as half the high voltage bus, approximately 200 V.

4.3 Preheating and ignition sequence

The turn-on sequence can be divided in three phases: preheating, ignition and normal lamp burning. The preheating of the lamp filaments is achieved by a high switching frequency f_{pre} , about 60 kHz, set by $R_{pre} = R12 + P1 + R13$ and $CF = C12$, to ensure that a current flows in the filaments without lamp ignition. In fact, the initial voltage applied across the lamp is below the strike potential. The duration of the preheating period T_{pre} is set by the capacitor $C_{pre} = C13$. The choice of this time is strictly dependent on the type of lamp. In the application T_{pre} has been set to 1.5 sec.

The ignition sequence begins after T_{pre} . The switching frequency decreases towards the resonance point (L2-C18), increasing the voltage across the lamp and causing the ignition. The time interval in which the frequency shifts, t_{sh} , amounts to $t_{sh} = t_{pre}/10 = 150$ ms. At the end of t_{sh} the frequency reaches 31 kHz (R18-C12), and the current feedback loop is then activated.

4.4 Current feedback loop

The current control is achieved by varying the switching frequency of the VCO. Since controlling the average current in the lamp means controlling the output power, it is quite easy to perform the control function. The operational amplifier compares the low-pass filtered half-bridge current with a reference, achieved by a portion of the voltage at pin 2 ($V_{PIN2} = 2$ V). This set-point could be changed by the trimmer P_1 to perform the dimming function. The amplifier's output is connected to the RING pin by D_4 and R_{16} . The diode D_4 is necessary to prevent the switching frequency from decreasing to below the value set by R18.

At start-up the voltage across R_{S2} ([Figure 15](#)) remains low until the lamp ignites. As such, the inverting input of the amplifier (pin 6) also stays low, while the non-inverting input (pin 7) is set to a constant voltage (set-point) by the divider R_{12} , P_1 and R_{13} .

Therefore, the amplifier's output (pin 5) remains high (5 V) until the lamp ignites, and D_4 is off. In this condition, the L6574 oscillates at f_{pre} .

Once the lamp strikes on (after t_{pre} and t_{sh}), the average voltage across R_{S2} increases and the feedback can regulate the lamp's current.

Figure 15. Current feedback loop

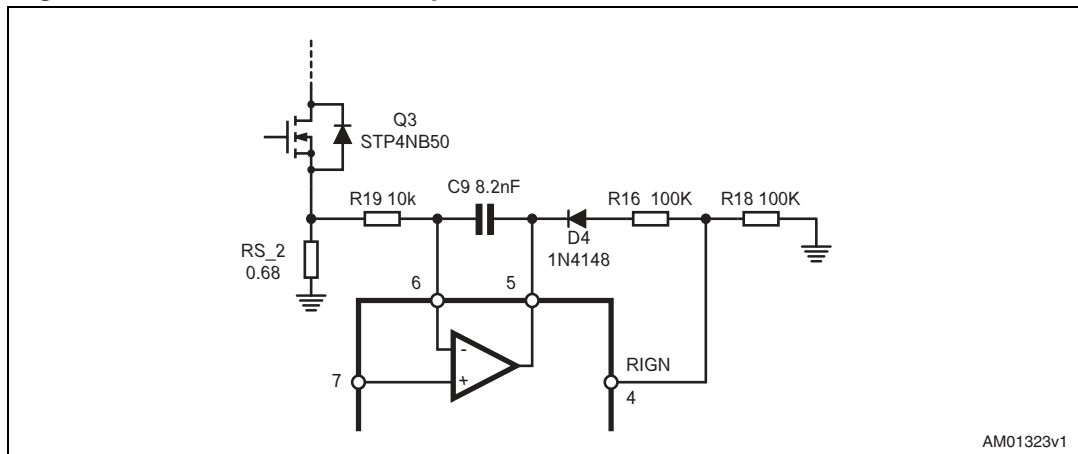

AM01323v1

Figure 16. Cpre waveform (Ch1) and amplifier output (Ch2)

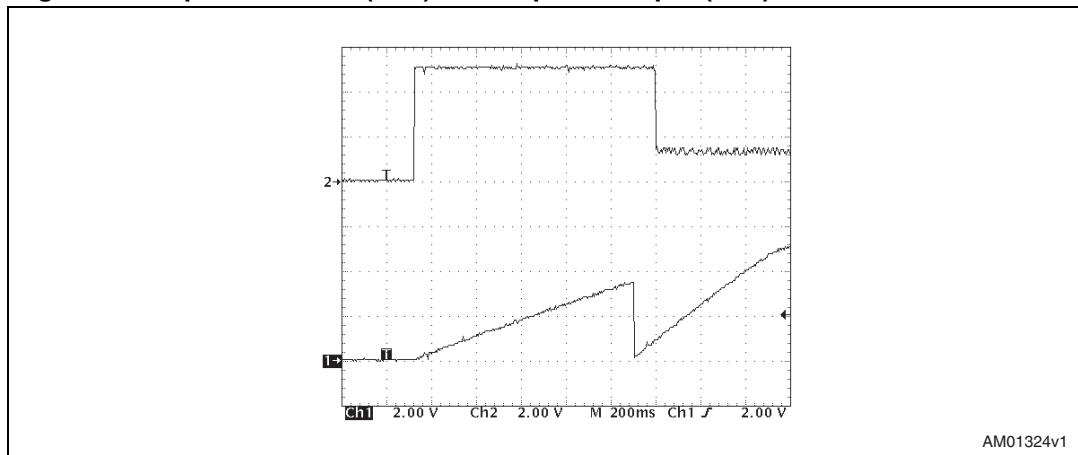

AM01324v1

4.5 Start-up and supply

The start-up procedure is very important in an application that contains two different sections.

The ballast section starts before the PFC, avoiding any extra voltage at the output of the PFC section, and so the L6561 dynamic OVP activation (see AN966). This behavior is guaranteed under all conditions because the VS turn-on threshold of the L6574 is lower than that of the L6561/2.

At start-up, the L6574 is powered by the resistor ($R_4 + R_5$). This resistor must be chosen so as to ensure the "before start-up current" of both the L6561 and L6574.

When the ballast section is running, the charge pump (C11, R14, R17, D3 and DZ1) enables supply to both devices. R17 and C10 enable reduction of noise at VCC.

4.6 Safety circuitry

In normal operation the inductive load ensures a zero voltage switching mode, but if the lamp is disconnected the switching losses in the power MOSFETs will increase considerably. To prevent this occurrence, a safety circuitry has been designed. When the lamp is connected the EN1 input (pin 8) of the L6574 is held close to ground by the series of R₂₉, the lamp filament and R_{S2}. If the lamp is not present, EN1 is pulled up to V_S by R₂₄, forcing the L6574 into a latched shutdown state. To resume normal operation, the ballast must be turned off, and then on again.

A second alarm has been designed to protect the application against any extra voltages which can arise if the lamp does not strike after the ignition sequence, for instance if the lamp is old. A partition of this extra voltage is rectified and delivered to the EN2 input (pin 9) of the L6574, restarting the start-up procedure (preheating and ignition sequences).

Figure 17. Open load safety circuit

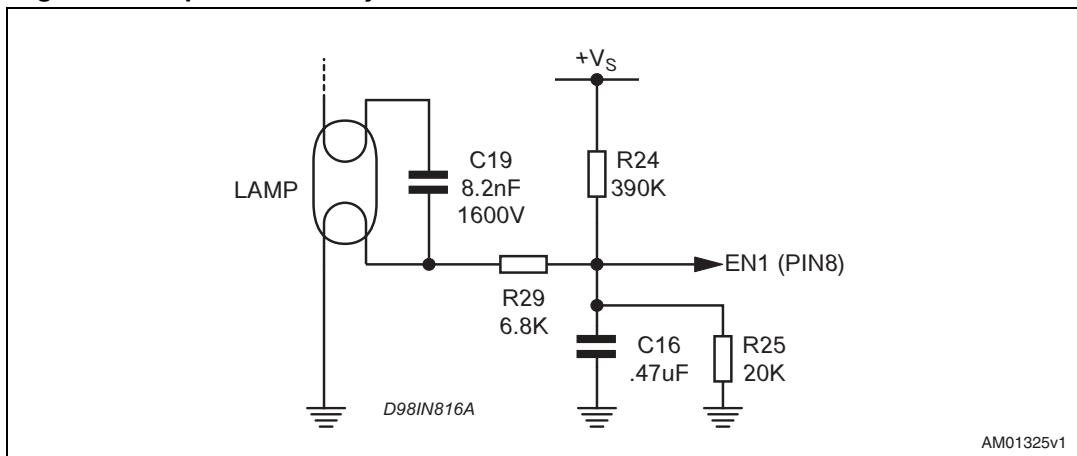
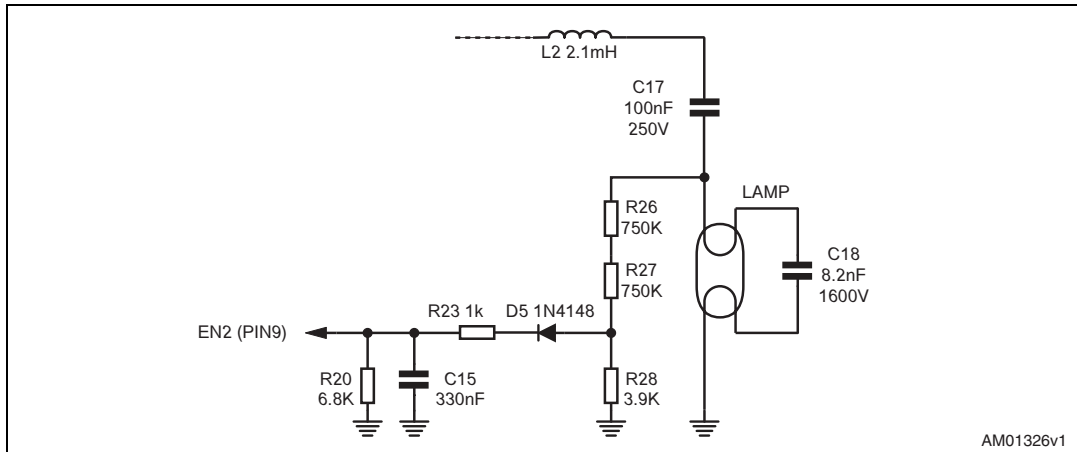

Figure 18. Extra voltage safety circuit



5 Design tips

5.1 Inductance and capacitor evaluation

To design an application with the L6574, a preliminary evaluation of the components can be done by fixing the lamp type and its electrical characteristics only.

This evaluation is an "iterative" process because some assumptions have to be made that need to be checked at the end of the process. [Figure 19](#) shows a simplified schematic of the load.

Figure 19. Simplified schematic of the lamp

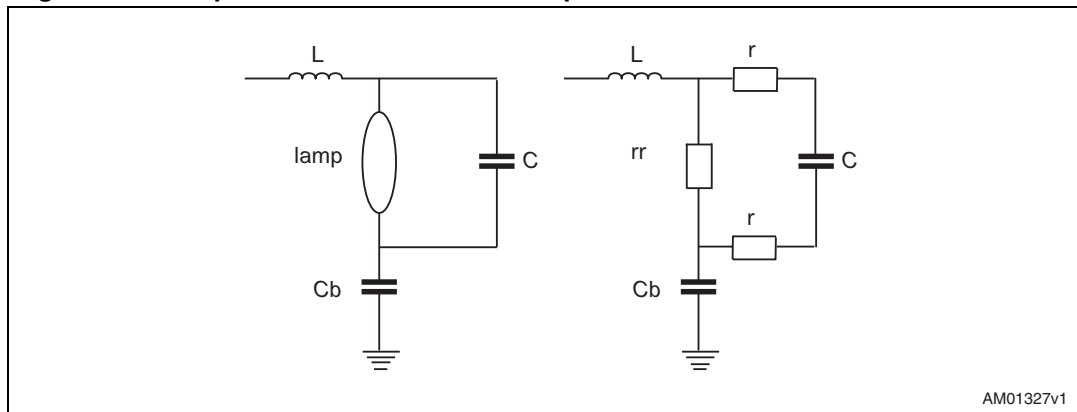

In [Figure 19](#) r is the lamp filament resistance, rr is the operating lamp equivalent resistance when the lamp is off or during preheating. rr is an open circuit.

First of all, one has to evaluate a proper inductance value.

L has to provide the right current value to the lamp when it is already ignited and is working ("choke" inductance). Therefore, L depends on the current required by the lamp, that is to say on the lamp's operating wattage and voltage, on the operating frequency f_{\min} , but also on the voltage across L and the lamp (V_b). The greater the V_b variation, the greater the inductance required to give a constant current to the lamp. V_b variations are due to the high-voltage bus variations and to the ripple on the half battery capacitor (C_b). The ripple depends on the size of C_b and a proper hypothesis has to be done on it to estimate the variation of V_b . Taking into account all this data and hypothesis, one can assume that during an operating condition most of the current flows into the lamp, not into C , and all the power delivered to the system is delivered to the lamp. V_{lamp} is the operating voltage across the lamp and P_{lamp} is the operating lamp wattage, so a good approximation to conduct the choke inductance is:

Equation 16

$$L = \frac{V_L}{I_L \cdot 2 \cdot \pi \cdot f} \rightarrow \frac{V_{\text{lamp}}}{P_{\text{lamp}}} \cdot \frac{(V_b - V_{\text{lamp}})}{2 \cdot \pi \cdot f_{\min}}$$

The second step is the evaluation of the capacitance across the lamp (C).

When the lamp is not yet ignited, C has to allow a sufficient current to flow into the lamp filament in order to preheat correctly. The power to be delivered to the lamp filaments (Pfil), the preheating frequency, the lamp filament resistance r and the maximum voltage to be applied across C without causing lamp ignition are constraints that help to evaluate the size of the capacitor. By setting the current through the lamp filament and the maximum voltage across the capacitor, one obtains a range of capacitor values.

Equation 17

$$C = I_C \cdot \frac{1}{2 \cdot \pi \cdot f \cdot V_C} \rightarrow \frac{\sqrt{P_{fil}}}{r} \cdot \frac{1}{2 \cdot \pi \cdot f_{pre} \cdot V_{Cmax}}$$

$$V_{Cmax} < V_{ignition}$$

These L, C_b and C values have to be corrected to obtain standard and commercial component values.

Using these values and lamp equivalent resistances, the transfer functions during the preheating and operating conditions can be calculated.

The preheating transfer function allows you to see if, when moving towards the resonant frequency (L-C), there is a frequency at which the voltage across the lamp enables its ignition. This frequency has to be between f_{max} and f_{min}. The gain of the transfer function depends on r also, but r changes greatly during the preheating phase (also 3 to 4 times) and this must be taken into consideration (see [Figure 20](#)).

Figure 20. Preheating transfer function

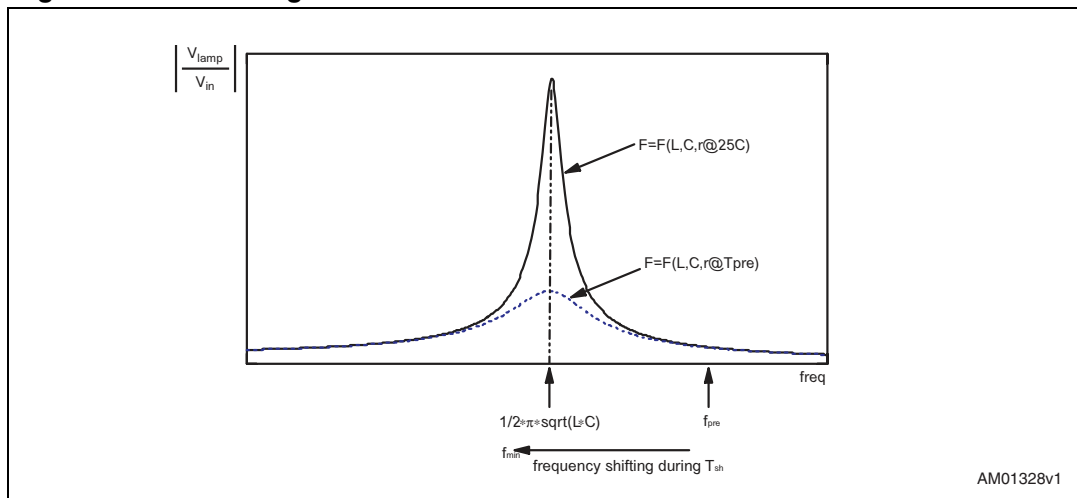

The operating transfer function can be used to check if the operating voltage across the lamp (at f = f_{min}) is similar to the one used to evaluate L ([Figure 21](#)).

Figure 21. Operating transfer function

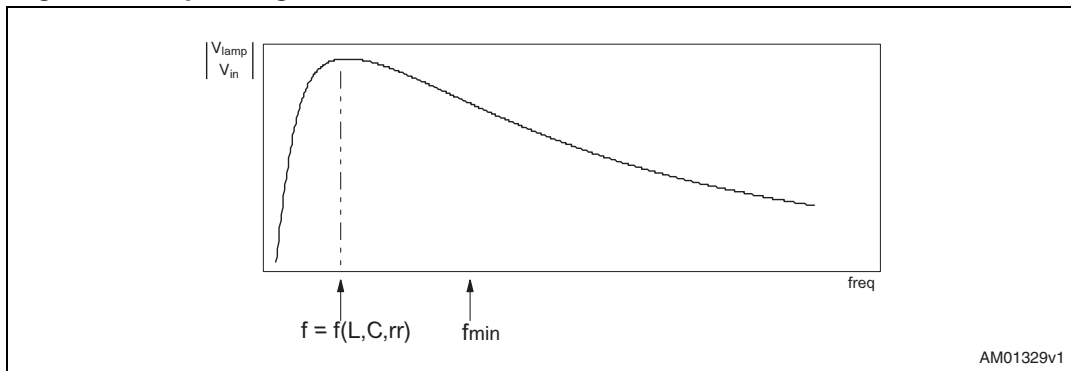

If one of these conditions is not verified, the evaluation process has to be redone changing the initial hypothesis (frequencies or assumption on the Cb ripple). If everything concurs, the values found can be used and a preliminary stage of design can be concluded. Further experiments may be required and the initial assumptions may need to be verified to correctly set the components and frequency values, and if necessary another evaluation process reiterated with better assumptions.

The following flow chart can help the iteration process.

Figure 22. Iterative process

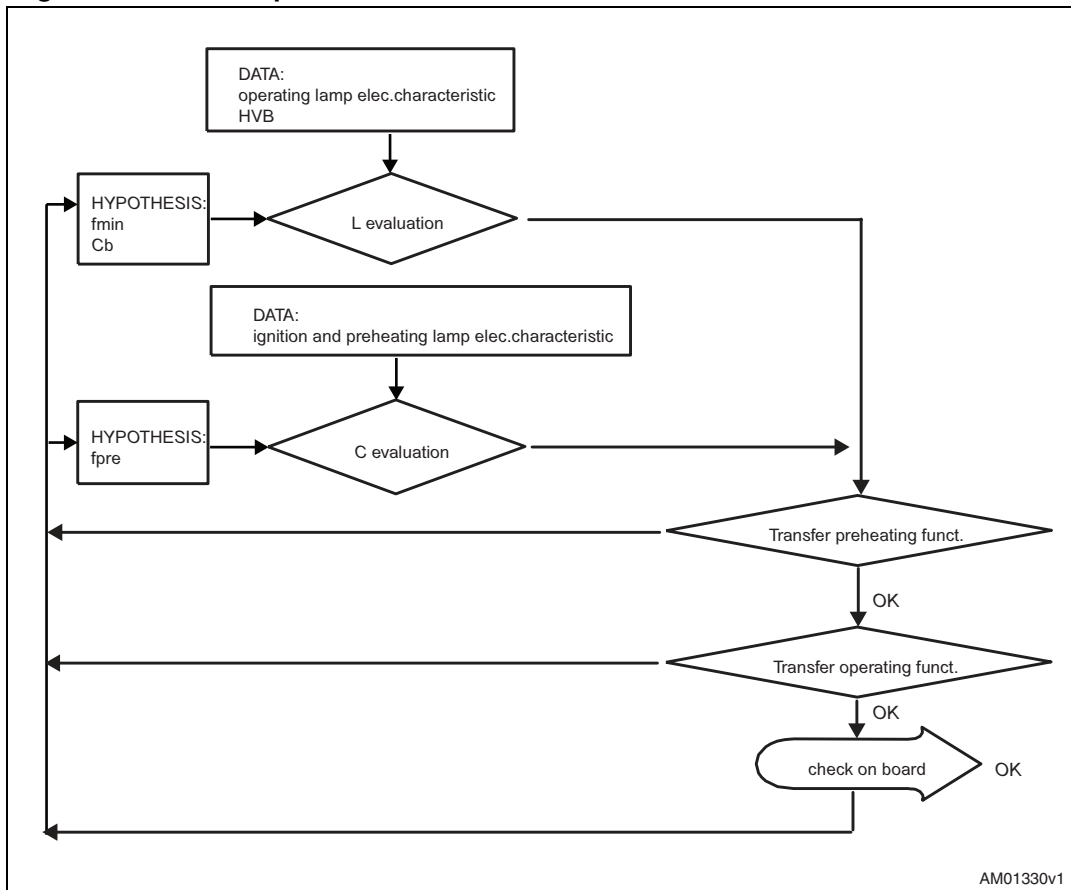

6 Dimming the lamp

The lamp is dimmed by changing the working frequency. The minimum working frequency is:

Equation 18

$$f_{\min} = \frac{1.41}{R_{\text{ign}} \cdot C_f}$$

To change the working frequency, one has to change the current that flows from pin 4. Using the circuitry shown in [Figure 15](#), the current that flows from pin 4 also depends on the amplifier's out pin (pin 5) voltage: if $V_5 > V_4$, there will be no current in R_{16} and the frequency will be equal to f_{\min} . On the other hand, when the amplifier's out voltage goes lower than V_4 , the current that flows from pin 4 will go into R_{16} and R_{18} . Pin 4 sees the parallel between R_{18} and an equivalent resistor that depends on V_5 and on the voltage of D_4 .

Equation 19

$$R_{16_{\text{equ}}} = \frac{V_4 \cdot R_{16}}{V_4 - V_{\text{diode4}} - V_5}$$

So the working frequency will be:

Equation 20

$$f_{\text{work}} = \frac{1.41}{(R_{\text{ign}} // R_{16_{\text{equ}}}) \cdot C_f}$$

and the max f_{working} is obtained when $V_5 = 0$ V.

For example, we can calculate a maximum frequency of ~53 kHz ($V_4 = 2$ V and assuming $V_{\text{diode3}} = 0.5$ V).

The dimming level is set by changing the value of the P1 potentiometer, which causes the amplifier's positive reference to change from 20-30 mV to 110-120 mV. If R_{16} is lowered, the maximum working frequency is increased and the dimming level lowered as well (the higher the frequency, the lower the current in the lamp's arc).

If one tries to dim the lamp towards a low power range (<20% of the electrical arc power) a common effect is the presence of stationary waves along the lamp tube and/or some flickering effects.

A common trick to get rid of these disturbances is to add a small continuous current flow inside the lamp (a few mA). The easiest way to do this is to add a resistor in parallel to the half battery capacitor (C17 in [Figure 13](#) and [Figure 18](#)). For instance, one can add 50 k Ω ($I = 200$ V/50 k $\Omega = 4$ mA), which is already very effective. Of course, the resistor has to be able to sustain the power dissipation caused by the current flow, so it is common to use many resistors connected in parallel.

Remember that this is only a tip. It helps but is not enough, and should be used together with the right frequency settings that must be chosen according to the type of lamp.

6.1 Dimming level and lamp turn-on

During the start-up sequence the frequency always goes from f_{\max} to f_{\min} , regardless of the dimming level, and it is only after this that the lamp's turn-on frequency moves towards higher frequencies. The delay during which $f = f_{\min}$ allows the lamp to turn on, but has the drawback of causing a "flash" that can be unpleasant. As the minimum length of this delay depends on the type of lamp, it is better to set it as low as possible, finding the best compromise.

The easiest way to set this delay is to act on the amplifier's compensation, that is, on C9: the higher C9, the longer the delay and the easier the lamp turn-on. Values up to 200 nF and more are commonly used.

7 Revision history

Table 3. Document revision history

Date	Revision	Changes
21-Jun-2004	9	Changed: figure 12 to 17 and changed formula on the page 19
13-Jul-2009	10	Document reformatted. English reviewed. Modified: <i>Equation 19</i> and <i>Section 6</i> .

Please Read Carefully:

Information in this document is provided solely in connection with ST products. STMicroelectronics NV and its subsidiaries ("ST") reserve the right to make changes, corrections, modifications or improvements, to this document, and the products and services described herein at any time, without notice.

All ST products are sold pursuant to ST's terms and conditions of sale.

Purchasers are solely responsible for the choice, selection and use of the ST products and services described herein, and ST assumes no liability whatsoever relating to the choice, selection or use of the ST products and services described herein.

No license, express or implied, by estoppel or otherwise, to any intellectual property rights is granted under this document. If any part of this document refers to any third party products or services it shall not be deemed a license grant by ST for the use of such third party products or services, or any intellectual property contained therein or considered as a warranty covering the use in any manner whatsoever of such third party products or services or any intellectual property contained therein.

UNLESS OTHERWISE SET FORTH IN ST'S TERMS AND CONDITIONS OF SALE ST DISCLAIMS ANY EXPRESS OR IMPLIED WARRANTY WITH RESPECT TO THE USE AND/OR SALE OF ST PRODUCTS INCLUDING WITHOUT LIMITATION IMPLIED WARRANTIES OF MERCHANTABILITY, FITNESS FOR A PARTICULAR PURPOSE (AND THEIR EQUIVALENTS UNDER THE LAWS OF ANY JURISDICTION), OR INFRINGEMENT OF ANY PATENT, COPYRIGHT OR OTHER INTELLECTUAL PROPERTY RIGHT.

UNLESS EXPRESSLY APPROVED IN WRITING BY AN AUTHORIZED ST REPRESENTATIVE, ST PRODUCTS ARE NOT RECOMMENDED, AUTHORIZED OR WARRANTED FOR USE IN MILITARY, AIR CRAFT, SPACE, LIFE SAVING, OR LIFE SUSTAINING APPLICATIONS, NOR IN PRODUCTS OR SYSTEMS WHERE FAILURE OR MALFUNCTION MAY RESULT IN PERSONAL INJURY, DEATH, OR SEVERE PROPERTY OR ENVIRONMENTAL DAMAGE. ST PRODUCTS WHICH ARE NOT SPECIFIED AS "AUTOMOTIVE GRADE" MAY ONLY BE USED IN AUTOMOTIVE APPLICATIONS AT USER'S OWN RISK.

Resale of ST products with provisions different from the statements and/or technical features set forth in this document shall immediately void any warranty granted by ST for the ST product or service described herein and shall not create or extend in any manner whatsoever, any liability of ST.

ST and the ST logo are trademarks or registered trademarks of ST in various countries.

Information in this document supersedes and replaces all information previously supplied.

The ST logo is a registered trademark of STMicroelectronics. All other names are the property of their respective owners.

© 2009 STMicroelectronics - All rights reserved

STMicroelectronics group of companies

Australia - Belgium - Brazil - Canada - China - Czech Republic - Finland - France - Germany - Hong Kong - India - Israel - Italy - Japan - Malaysia - Malta - Morocco - Philippines - Singapore - Spain - Sweden - Switzerland - United Kingdom - United States of America

www.st.com