

**Product Features**

- Solid-state linear amplifier design
- GaN on SiC HEMT
- Small and light weight
- Wide Band Operation 500 ~ 2500MHz
- 50 Ohm Input/Output impedance matched
- Highly reliable and rugged design
- Harsh environmental condition
- High efficiency
- 50W typical P<sub>sat</sub>
- Built-in sequence bias included

**Applications**

- Broadband communication
- Broadcasting
- General purpose RF amplifier
- Linear applications in the L/S Frequency Bands

**Description**

RUP15050-12 has been designed for RF system application frequencies from 500 ~ 2500MHz.

This Pallet Amplifier uses GaN on SiC HEMT technology which performs high breakdown voltage, high linearity, wide bandwidth and high efficiency.

**Electrical Specifications @ VDD=30VDC, T=25°C, 50Ω System**

PARAMETER	UNIT	MIN	TYP	MAX	SYMBOL
Operating Frequency	MHz	500	-	2500	f <sub>O</sub>
Operating Bandwidth	MHz	-	2000	-	BW
Output Power CW	W	-	50	-	P <sub>SAT</sub>
Output Power @ P <sub>3dB</sub> G.C.P	W	-	20	-	P <sub>3dB</sub>
Small Signal Gain	dB	45	60	-	G <sub>S</sub>
Small Signal Gain Flatness	dB	-	± 1.5	± 2.0	ΔG <sub>S</sub>
Input VSWR	-	-	2.0:1	2.5 : 1	S <sub>11</sub>
Harmonics @ P <sub>1dB</sub> G.C.P	dBc	10	-	-	H <sub>P1dB</sub>
Spurious Signals	dBc	60	70	-	Spur
Operating Voltage	V	28	30	32	V
Supply Current @ P <sub>sat</sub>	A	-	7	-	I <sub>DD</sub>
Supply Current @ P <sub>3dB</sub>	A	-	6	-	I <sub>DD</sub>

\* Please DO NOT ENTER RF INPUT POWER OVER +5dBm. (to prevent the main transistor from damaging)

**Environmental Characteristics**

PARAMETER	UNIT	MIN	TYP	MAX	SYMBOL
Operating Case Temperature	°C	0	-	70	T <sub>C</sub>
Storage Temperature	°C	-40	-	85	T <sub>S</sub>

## Typical Performance @ 25°C

Freq.	P3 Output Power, Current, Efficiency				Psat Output Power, Current, Efficiency			
	Output	Output	Current	Efficiency	Output	Output	Current	Efficiency
MHz	dBm	W	A	%	dBm	W	A	%
500	46.35	43.15	4.17	36.96	46.35	43.15	4.17	36.96
600	46.60	45.71	4.40	37.10	46.60	45.71	4.40	37.10
700	47.00	50.00	5.52	32.43	47.10	51.29	5.69	32.19
800	47.00	50.00	7.04	25.43	47.10	51.29	7.31	25.06
900	47.00	50.00	7.29	24.55	48.04	63.68	8.82	25.79
1000	47.00	50.00	7.18	24.93	49.30	85.11	9.47	32.10
1100	47.00	50.00	7.32	24.45	50.20	104.71	10.56	35.41
1200	47.00	50.00	6.37	28.10	48.42	69.50	7.54	32.92
1300	47.00	50.00	5.34	33.52	50.00	100.00	8.90	40.13
1400	47.00	50.00	4.63	38.66	48.51	70.96	6.02	42.10
1500	47.00	50.00	5.24	34.16	47.65	58.21	6.38	32.58
1600	47.00	50.00	5.78	30.97	47.32	53.95	6.34	30.39
1700	47.00	50.00	6.27	28.55	47.86	61.09	7.23	30.18
1800	47.00	50.00	6.12	29.25	48.11	64.71	7.45	31.02
1900	47.00	50.00	6.29	28.46	48.13	65.01	7.59	30.59
2000	47.00	50.00	6.30	28.41	48.40	69.18	7.99	30.92
2100	47.00	50.00	6.27	28.55	49.00	79.43	7.99	35.51
2200	47.00	50.00	6.06	29.54	48.99	79.25	7.80	36.29
2300	47.00	50.00	5.61	31.91	49.05	80.35	7.32	39.20
2400	47.00	50.00	5.29	33.84	48.01	63.24	6.16	36.67
2500	46.58	45.50	5.68	28.61	46.58	45.50	5.68	28.61

Typical Performance @ 25°C

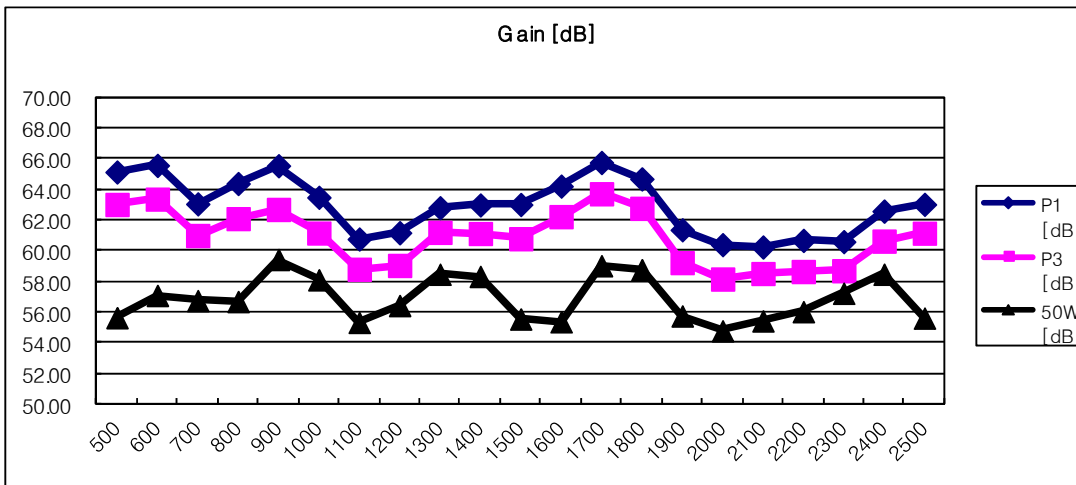
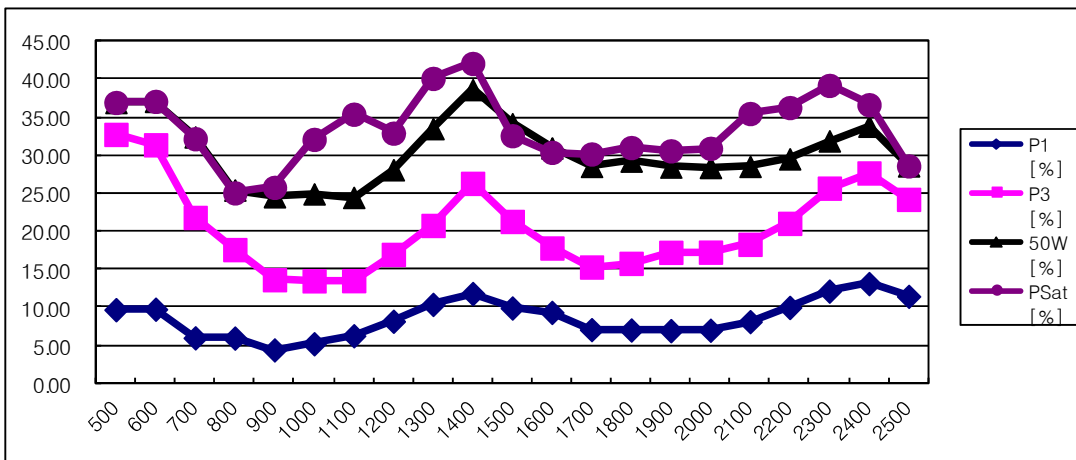
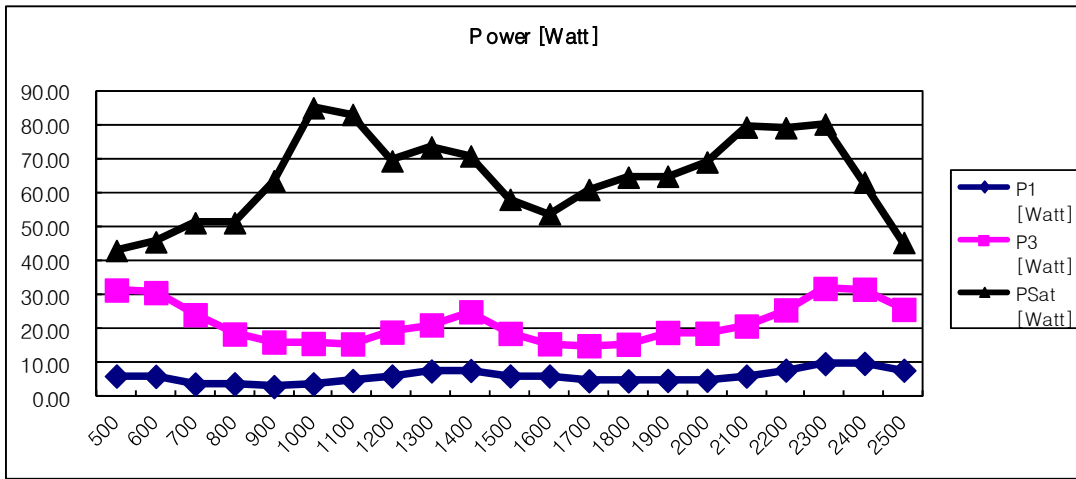

Small Signal Gain @ Input Power : -10dBm, 25°C

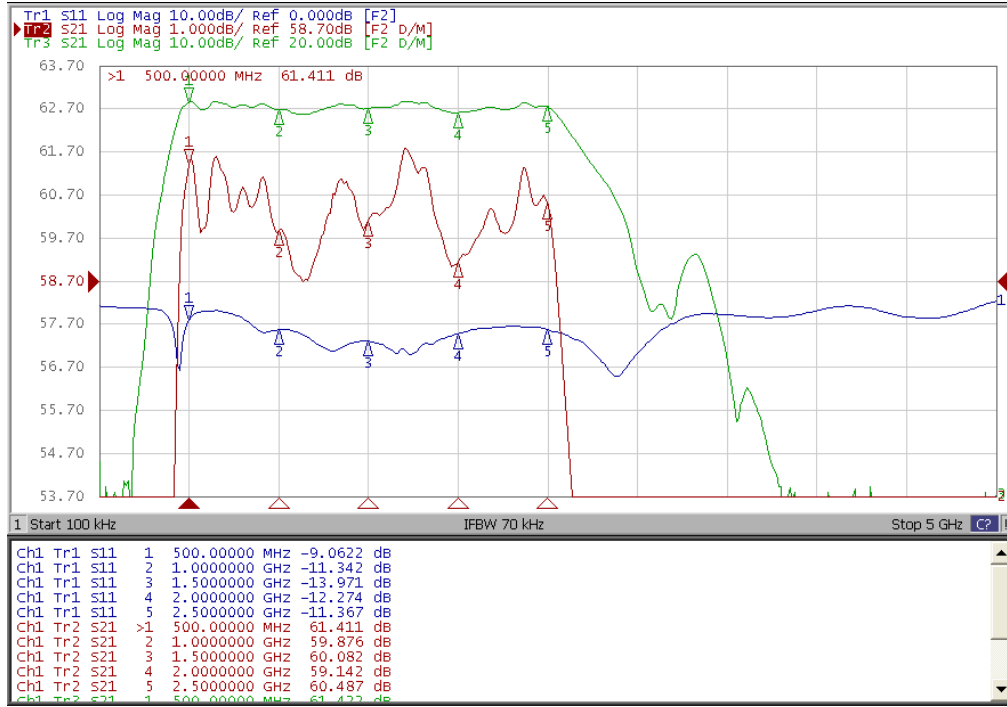

**Mechanical Specifications**

PARAMETER	UNIT	VALUE	LIMIT
Dimensions ( L x W x H )	mm	140.0 x 90 x 19	Max
RF Connectors In/Out	-	SMA Female	-
Cooling	-	External Heat sink + airflow	-

**Outline Drawing**

\* Unit: mm[inch] | Tolerance ±0.2[.008]

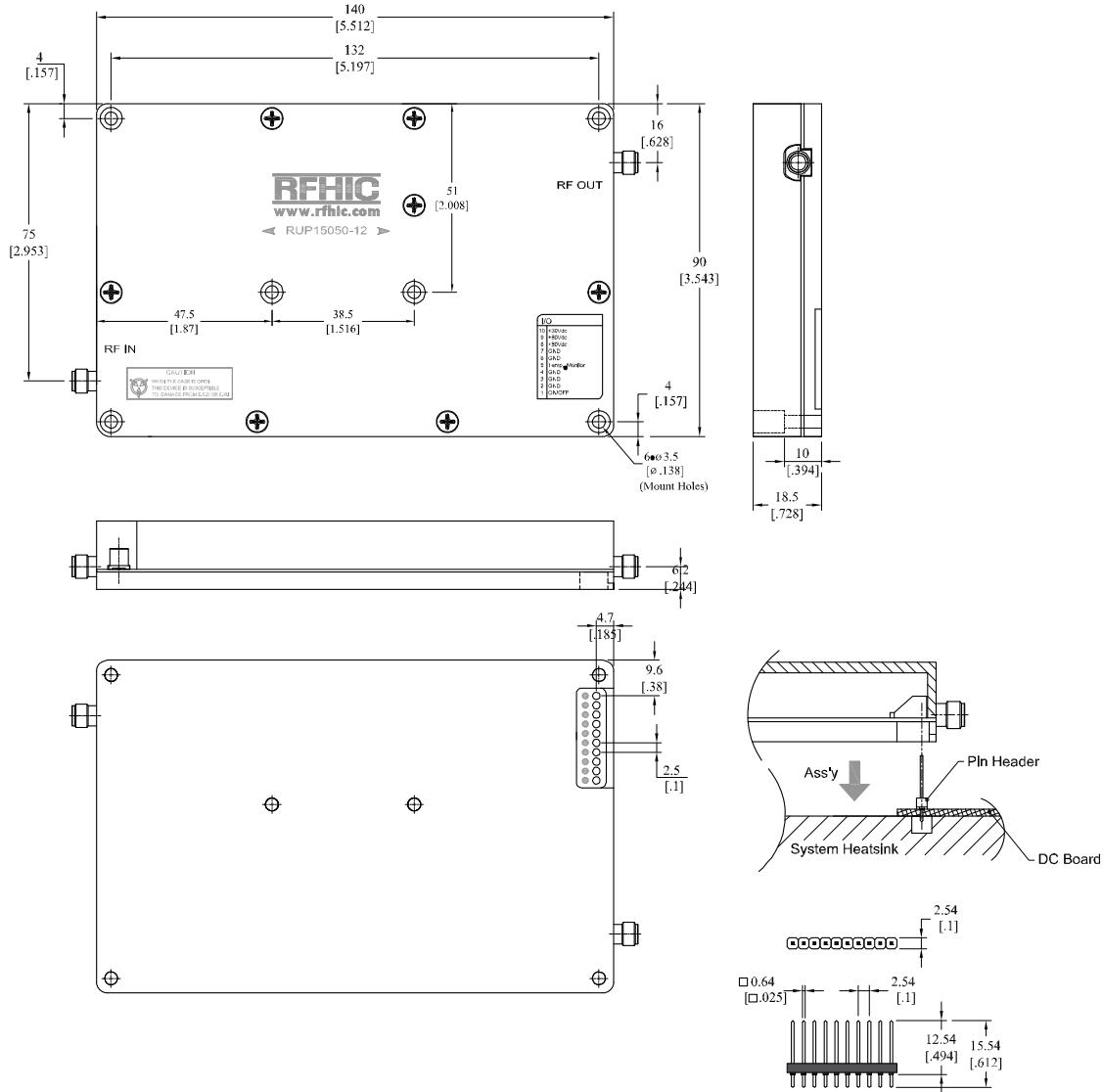

**Pin Description**

Pin No	Description	Specifications	Pin No	Description	Specifications
1	On/Off	Enable / Disable	6	GND	Ground
2	GND	Ground	7	GND	Ground
3	GND	Ground	8	V <sub>DD</sub>	+30 Drain Voltage
4	GND	Ground	9	V <sub>DD</sub>	+30 Drain Voltage
5	Temp	Reporting Temperature data [0.75V/25°C]	10	V <sub>DD</sub>	+30 Drain Voltage

**Revision History**

<b>Part Number</b>	<b>Release Date</b>	<b>Version</b>	<b>Modification</b>	<b>Data Sheet Status</b>
RUP15050-12	2011.03.10	1.0	TR Package Change	-

RFHIC Corporation reserves the right to make changes to any products herein or to discontinue any product at any time without notice. While product specifications have been thoroughly examined for reliability, RFHIC Corporation strongly recommends buyers to verify that the information they are using is accurate before ordering. RFHIC Corporation does not assume any liability for the suitability of its products for any particular purpose, and disclaims any and all liability, including without limitation consequential or incidental damages. RFHIC products are not intended for use in life support equipment or application where malfunction of the product can be expected to result in personal injury or death. Buyer uses or sells such products for any such unintended or unauthorized application, buyer shall indemnify, protect and hold RFHIC Corporation and its directors, officers, stockholders, employees, representatives and distributors harmless against any and all claims arising out of such unauthorized use.

Sales, inquiries and support should be directed to the local authorized geographic distributor for RFHIC Corporation. For customers in the US, please contact the US Sales Team at 919-677-8780. For all other inquiries, please contact the International Sales Team at 82-31-250-5078.