



# 4D SYSTEMS

*TURNING TECHNOLOGY INTO ART*

## DIABLO16 Processor Embedded Graphics Processor

**DATASHEET**

**Document Date: 13<sup>th</sup> August 2013**  
**Document Revision: 1.1**

# Contents

---

<b>1. Description</b> .....	<b>4</b>
<b>2. Features</b> .....	<b>4</b>
<b>3. Applications</b> .....	<b>5</b>
<b>4. Pin Summary</b> .....	<b>6</b>
<b>5. Pin Description</b> .....	<b>9</b>
5.1. Display Interface .....	9
5.2. SPI Interface – Memory Card .....	10
5.3. Serial Ports – TTL Level Serial .....	11
5.4. Audio Interface.....	12
5.5. Touch Screen Interface .....	12
5.6. GPIO - General Purpose IO .....	13
5.7. System Pins .....	13
5.8. Alternate Pin Funtions - Overview.....	14
5.9. SPI.....	15
5.10. I <sup>2</sup> C.....	16
5.11. Pulse Out .....	16
5.12. PWM Out.....	17
5.13. Pin Counter .....	17
5.14. Quadrature In.....	18
5.15. Analog Inputs .....	18
<b>6. DIABLO16 Architecture</b> .....	<b>19</b>
6.1. FLASH Storage and RAM allocation.....	20
6.2. PmmC Loader + Internal Functions .....	20
6.3. Display Driver .....	20
6.4. User FLASH Memory Banks .....	20
6.5. RAM (Both System and User) .....	21
<b>7. 4DGL - Software Language</b> .....	<b>22</b>
<b>8. In Circuit Serial Programming ICSP</b> .....	<b>22</b>
<b>9. System Registers Memory Map</b> .....	<b>23</b>
<b>10. Memory Cards - FAT16 Format</b> .....	<b>25</b>
<b>11. Hardware Tools</b> .....	<b>25</b>
11.1. 4D Programming Cable & Adaptor.....	25
11.2. Evaluation Display Modules .....	26
<b>12. 4D Systems - Workshop 4 IDE</b> .....	<b>26</b>

12.1. Workshop 4 – Designer Environment .....	27
12.2. Workshop 4 – ViSi Environment.....	27
12.3. Workshop 4 – ViSi Genie Environment .....	27
<b>13. Reference Design .....</b>	<b>28</b>
<b>14. Package Details.....</b>	<b>29</b>
<b>15. PCB Land Pattern .....</b>	<b>30</b>
<b>16. Specifications and Ratings .....</b>	<b>31</b>
<b>17. Legal Notice.....</b>	<b>32</b>
<b>18. Contact Information.....</b>	<b>32</b>

## 1. Description

The DIABLO16 Processor is the latest addition to the 4D Systems processor range, providing more power, more FLASH, more RAM and more features than the PICASO Processor.

The DIABLO16 Processor is a custom embedded 4DGL graphics controller designed to interface with many popular OLED and LCD display panels. With its powerful graphics, text, image, and animation abilities built-in, along with numerous more features makes the Diablo16 a single chip solution for a wide variety of LCD and OLED display solutions.

The DIABLO16 offers a simple plug-n-play interface to many 16-bit 80-Series colour LCD and OLED displays, and is designed to work with minimal design effort as all of the data and control signals are provided by the chip to interface directly to the display. This offers enormous advantage to the designer in development time and cost saving and takes away all of the burden of low level design.

The DIABLO16 belongs to 4D Systems family of processors powered by a highly optimised soft core virtual engine, EVE (Extensible Virtual Engine). EVE is a proprietary, high performance virtual processor with an extensive byte-code instruction set optimised to execute compiled 4DGL programs. 4DGL (4D Graphics Language) was specifically developed from ground up for the EVE engine core. It is a high level language which is easy to learn and simple to understand yet powerful enough to tackle many embedded graphics applications.

The processor offers a comprehensive set of I/O features and can interface to SPI, I2C, serial, digital, and analog devices, and provides a wealth of features such as PWM, Quadrature, PulseOut and Pin Counter functions. Provision is also made for a dedicated PWM audio output that supports audio WAV files and complex sound generation.

All of the display built-in driver libraries implement and share the same high-level function interface. This allows your GUI application to be portable to different display controller types.

4D Systems software development IDE called Workshop4 is FREE and there are no licensing requirements.

## 2. Features

- 6 banks of 32750 bytes of Flash memory for User Application Code and Data
- 32Kb of SRAM purely for the User.
- 16 General Purpose I/O pins for user interfacing, which include 4 configurable Analog Inputs.
- The GPIO is variously configurable for alternative functions such as:
  - 3x I<sup>2</sup>C channels available
  - 1x dedicated for SD Card and 3x configurable SPI channels available
  - 1x dedicated and 3x configurable TTL Serial comm ports available
  - Up to 6 GPIO can be used as Pin Counters
  - Up to 6 GPIO for PWM (simple and Servo)
  - Up to 10 GPIO for Pulse Output
  - Up to 14 GPIO can be configured for Quadrature Encoder Inputs (2 channels)
- FAT16 file services.
- Dedicated SPI interface for SDHC/SD memory card for multimedia storage and data logging purposes (micro-SD with up to 2GB and SDHC memory cards starting from 4GB and above).
- 4-Wire Resistive Touch panel interface.
- Audio support for wave files and complex sound generation with a dedicated 16-bit PWM audio output.
- 8 x 16 bit timers with 1 millisecond resolution.
- Low-cost OLED, LCD and TFT display graphics user interface solution.
- Ideal as a standalone embedded graphics processor or interface to any host controller as a graphics co-processor.
- Connect to almost any colour display that supports an 80-Series 16 bit wide CPU interface. All data and control signals are provided.
- RoHS compliant.
- Available in a 64 pin TQFP 10mm x 10mm package.

### 3. Applications

- General purposes embedded graphics.
- Elevator control systems.
- Point of sale terminals.
- Electronic gauges and metres.
- Test and measurement and general purpose instrumentation.
- Industrial control and Robotics.
- Automotive system displays.
- GPS navigation systems.
- Medical Instruments and applications.
- Home appliances and Smart Home Automation.
- Security and Access control systems.
- Gaming equipment.
- Aviation systems.
- HMI with touch panels.



## 4. Pin Summary

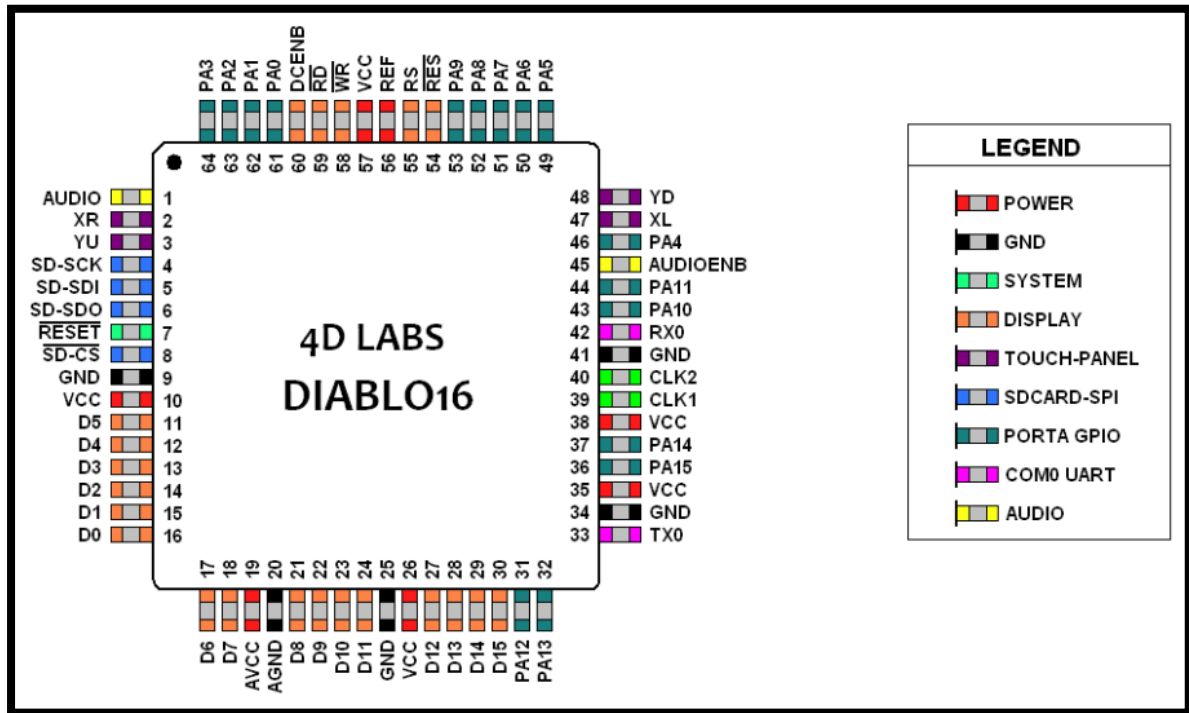

DIABLO16 Processor Pin Out			
Pin	Symbol	I/O	Description
1	AUDIO	O	Pulse Width Modulated (PWM) Audio output. Connect this pin to a 2 stage low pass filter then into an audio amplifier.
2	XR	A	4-Wire Resistive Touch Screen Right signal. Connect this pin to XR or X+ signal of the touch panel.
3	YU	A	4-Wire Resistive Touch Screen Up signal. Connect this pin to YU or Y+ signal of the touch panel.
4	SD-SCK	O	SPI Serial Clock output. SD memory card use only. Connect this pin to the SPI Serial Clock (SCK) signal of the memory card.
5	SD-SDI	I	SPI Serial Data Input. SD memory card use only. Connect this pin to the SPI Serial Data Out (SDO) signal of the memory card.
6	SD-SDO	O	SPI Serial Data Output. SD memory card use only. Connect this pin to the SPI Serial Data In (SDI) signal of the memory card.
7	RESET	I	Master Reset signal. Connect a 4.7K pull-up resistor from this pin to VCC. Active Low
8	SD-CS	O	SD Memory-Card Chip Select. SD memory card use only. Connect this pin to the Chip Enable (CS) signal of the memory card.
19	AVCC	P	Analog Positive Supply. Option 1: Connect to VCC via a 12ohm resistor, and with a 4.7uF Capacitor to AGND Option 2: Connect to VCC via an Inductor with has a resistance of less than 1ohm, and a capacity greater than 10mA, and a 4.7uF Capacitor to AGND. This option provides the best ADC noise rejection.
20	AGND	P	Analog Ground. Connect this to GND.
9, 25, 34, 41	GND	P	Device Ground.
10, 26, 38, 57	VCC	P	Device Positive Supply.

I = Input, O = Output, P = Power, A = Analogue

DIABLO16 Processor Pin Out (continued...)			
Pin	Symbol	I/O	Description
11	D5	I/O	Display Data Bus bit 5.
12	D4	I/O	Display Data Bus bit 4.
13	D3	I/O	Display Data Bus bit 3.
14	D2	I/O	Display Data Bus bit 2.
15	D1	I/O	Display Data Bus bit 1.
16	D0	I/O	Display Data Bus bit 0.
17	D6	I/O	Display Data Bus bit 6.
18	D7	I/O	Display Data Bus bit 7.
21	D8	I/O	Display Data Bus bit 8.
22	D9	I/O	Display Data Bus bit 9.
23	D10	I/O	Display Data Bus bit 10.
24	D11	I/O	Display Data Bus bit 11.
27	D12	I/O	Display Data Bus bit 12.
28	D13	I/O	Display Data Bus bit 13.
29	D14	I/O	Display Data Bus bit 14.
30	D15	I/O	Display Data Bus bit 15.
31	PA12	I	General Purpose Input only pin. This pin is 5.0V tolerant.
32	PA13	I	General Purpose Input only pin. This pin is 5.0V tolerant.
33	TX0	O	Dedicated Asynchronous Serial port Transmit pin, TX. Connect this pin to host micro-controller Serial Receive (Rx) signal. The host receives data from DAIBLO16 via this pin. This pin is 5.0V tolerant. Processor Programming Pin.
36	PA15	I/O	General Purpose I/O. This pin is 5.0V tolerant.
37	PA14	I/O	General Purpose I/O. This pin is 5.0V tolerant.
39	CLK1	I	Device Clock input 1 of a 12MHz crystal.
40	CLK2	O	Device Clock input 2 of a 12MHz crystal.
42	RX0	I	Asynchronous Serial port Receive pin, RX. Connect this pin to host micro-controller Serial Transmit (Tx) signal. The host transmits data to DIABLO16 via this pin. This pin is 5.0V tolerant. Processor Programming Pin.
43	PA10	I/O	General Purpose I/O. This pin is 5.0V tolerant.
44	PA11	I/O	General Purpose I/O. This pin is 5.0V tolerant.
45	AUDIOENB	O	Audio Enable. Connect this pin to amplifier control. LOW: Disable external Audio amplifier. HIGH: Enable external Audio amplifier.
46	PA4	I/O	General Purpose I/O. This pin is 5.0V tolerant.
47	XL	O	4-Wire Resistive Touch Screen Left signal. Connect this pin to XL or X- signal of the touch panel.
48	YD	O	4-Wire resistive touch screen bottom signal. Connect this pin to YD or Y- signal of the touch panel.
49	PA5	I/O	General Purpose I/O. This pin is 5.0V tolerant.
50	PA6	I/O	General Purpose I/O. This pin is 5.0V tolerant.
51	PA7	I/O	General Purpose I/O. This pin is 5.0V tolerant.
52	PA8	I/O	General Purpose I/O. This pin is 5.0V tolerant.
53	PA9	I/O	General Purpose I/O. This pin is 5.0V tolerant.

I = Input, O = Output, P = Power, A = Analogue

DIABLO16 Processor Pin Out (continued...)			
Pin	Symbol	I/O	Description
54	RES	O	Display RESET. DIABLO16 initialises the display by strobing this pin LOW. Connect this pin to the Reset (RES) signal of the display.
55	RS	O	Display Register Select. LOW: Display index or status register is selected. HIGH: Display GRAM or register data is selected. Connect this pin to the Register Select (RS or A0 or C/D or similar naming convention) signal of the display.
56	REF	P	Internal voltage regulator filter capacitor pin. Connect a 4.7uF to 10uF capacitor from this pin to Ground. Position capacitor as close as possible.
58	WR	O	Display Write strobe signal. DIABLO16 asserts this signal LOW when writing data to the display. Connect this pin to the Write (WR) signal of the display.
59	RD	O	Display Read strobe signal. DIABLO16 asserts this signal LOW when reading data from the display. Connect this pin to the Read (RD) signal of the display.
60	DCENB	O	DC-DC high voltage enable signal. This maybe the high voltage that drives the LCD backlight or the OLED panel supply. High: Enable DC-DC converter. Low : Disable DC-DC converter.
61	PA0	I/O/A	General Purpose I/O pin with Analog Capability. This pin is 5.0V tolerant when used as a Digital, with a range of 0-3.3V when used as an Analog Input
62	PA1	I/O/A	General Purpose I/O pin with Analog Capability. This pin is 5.0V tolerant when used as a Digital, with a range of 0-3.3V when used as an Analog Input
63	PA2	I/O/A	General Purpose I/O pin with Analog Capability. This pin is 5.0V tolerant when used as a Digital, with a range of 0-3.3V when used as an Analog Input
64	PA3	I/O/A	General Purpose I/O pin with Analog Capability. This pin is 5.0V tolerant when used as a Digital, with a range of 0-3.3V when used as an Analog Input

I = Input, O = Output, P = Power, A = Analogue

**NOTE:** Please refer to section 5 for more information about these pins.

## 5. Pin Description

The DIABLO16 Processor provides both a hardware and a software interface. This section describes in detail the hardware interface pins of the device.

### 5.1. Display Interface

The DIABLO16 supports LCD and OLED displays with an 80-Series 16-bit wide CPU data interface. The connectivity to the display is easy and straight forward. The DIABLO16 generates all of the necessary timing to drive the display.

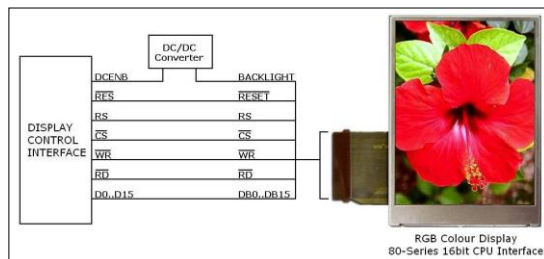

CS	RS	RD	WR	Operation
0	0	0	1	Read Display Status Register
0	0	1	0	Write Display Index Register
0	1	0	1	Read Display GRAM Data
0	1	1	0	Write Register or GRAM Data
1	X	X	X	No Operation

Display Operation Table

#### D0-D15 pins (Display Data Bus):

The Display Data Bus (D0-D15) is a 16-bit bidirectional port and all display data writes and reads occur over this bus. Other control signals such as RW, RD CS, and RS synchronise the data transfer to and from the display.

#### CS pin (Display Chip Select):

The access to the display is only possible when the Display Chip Select (CS) is asserted LOW. Connect this pin to the Chip Select (CS) signal of the display.

#### RS pin (Display Register Select):

The RS signal determines whether a register command or data is sent to the display.

**LOW:** Display index or status register is selected.

**HIGH:** Display GRAM or register data is selected.

Connect this pin to the Register Select (RS) signal of the display. Different displays utilise various naming conventions such as RS, A0, C/D or similar. Be sure to check with your display manufacturer for the correct name and function.

#### RES pin (Display Reset):

Display RESET. DIABLO16 initialises the display by strobing this pin LOW. Connect this pin to the Reset (RES) signal of the display.

#### DCENB pin (External DC/DC Enable):

DC-DC high voltage enable signal. This pin may drive the circuit which enables the high voltage that drives the LCD backlight or the OLED panel supply.

#### WR pin (Display Write):

This is the display write strobe signal. The DIABLO16 asserts this signal LOW when writing data to the display in conjunction with the display data bus (D0-D15). Connect this pin to the Write (WR) signal of the display.

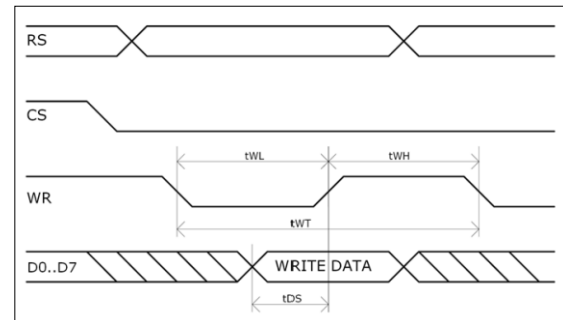

Item	Sym	Min	Typ	Max	Unit
Write Low Pulse	tWL	50	-	-	ns
Write High Pulse	tWH	50	-	-	ns
Write Bus Cycle Total	tWT	100	-	-	ns
Write Data Setup	tDS	25	-	-	ns

#### RD pin (Display Read):

This is the display read strobe signal. The DIABLO16 asserts this signal LOW when reading data from the display in conjunction with the display data bus (D0-D15). Connect this pin to the Read (RD) signal of the display.

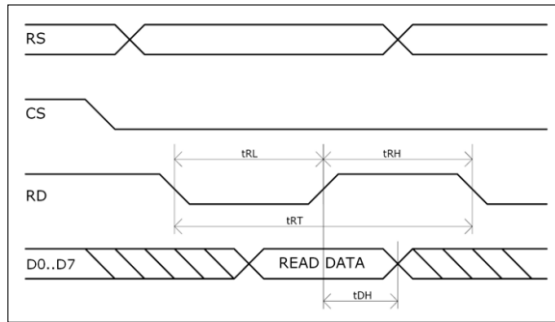

Item	Sym	Min	Typ	Max	Unit
Read Low Pulse	tRL	150	-	-	ns
Read High Pulse	tRH	150	-	-	ns
Read Bus Cycle Total	tRT	300	-	-	ns
Read Data Hold	tDH	75	-	-	ns

## 5.2. SPI Interface – Memory Card

The DIABLO16 supports SD, micro-SD and MMC memory cards via its dedicated hardware SPI interface. The DIABLO16 has 4 SPI channels, and the first is dedicated for this. The memory card is used for all multimedia file retrieval such as images, animations and movie clips and the SPI interface is dedicated for this purpose only. The memory card can also be used as general purpose storage for data logging applications (RAW and FAT16 format support). Support is available for micro-SD with up to 2GB capacity and for high capacity HC memory cards starting from 4GB and above.

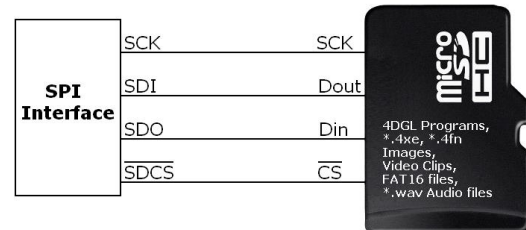

### SDI pin (SPI Serial Data In):

The SPI Serial Data Input (SDI). SD memory card use only. Connect this pin to the SPI Serial Data Out (SDO) signal of the memory card.

### SDO pin (SPI Serial Data Out):

The SPI Serial Data Output (SDI). SD memory card use only. Connect this pin to the SPI Serial Data In (SDI) signal of the memory card.

### SCK pin (SPI Serial Clock):

The SPI Serial Clock output (SCK). SD memory card use only. Connect this pin to the SPI Serial Clock (SCK) signal of the memory card.

### SDCS pin (SD Memory Card Chip Select):

SD Memory-Card Chip Select (SDCS). SD memory card use only. Connect this pin to the Chip Enable (CS) signal of the memory card.

### 5.3. Serial Ports – TTL Level Serial

The **DIABLO16** Processor has three hardware asynchronous serial ports that can be configured on a variety of the processors GPIO pins. TX/RX0 is dedicated and is fixed on to pins 33 (TX0) and 43 (RX0). All of the DIABLO16's serial ports can be used to communicate with external serial devices.

TX/RX0 are referred to as COM0, and is the only one used for programming the DIABLO16 itself.

The primary features are:

- Full-Duplex 8 bit data transmission and reception.
- Data format: 8 bits, No Parity, 1 Stop bit.
- Independent Baud rates from 300 baud up to 600K baud.
- Single byte transmits and receives or a fully buffered service. The buffered service feature runs in the background capturing and buffering serial data without the user application having to constantly poll any of the serial ports. This frees up the application to service other tasks.

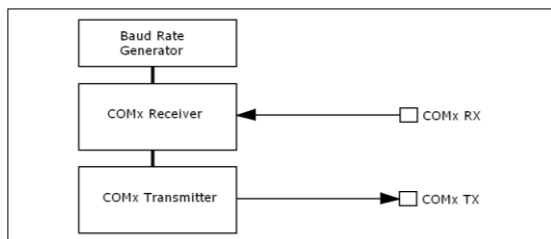

A single byte serial transmission consists of the start bit, 8-bits of data followed by the stop bit. The start bit is always 0, while a stop bit is always 1. The LSB (Least Significant Bit, Bit 0) is sent out first following the start bit. Figure below shows a single byte transmission timing diagram.

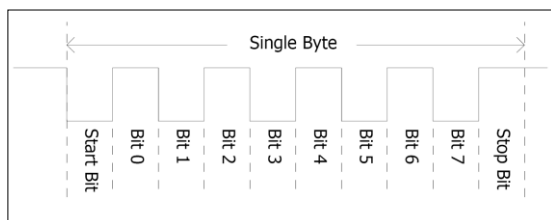

COM0 is also the primary interface for 4DGL user program downloads and chip configuration PmmC programming. Once the compiled 4DGL application program (EVE byte-code) is downloaded and the user code starts executing, the serial port is then available to the user application. Refer to **Section 7. In-Circuit-Serial-Programming (ICSP)** for more details on PmmC/Firmware programming.

#### TX0 pin (Serial Transmit COM0):

Dedicated Asynchronous Serial port COM0 transmit pin, TX0. Connect this pin to external serial device receive (Rx) signal. This pin is 5.0V tolerant.

#### RX0 pin (Serial Receive COM0):

Dedicated Asynchronous Serial port COM0 receive pin, RX0. Connect this pin to external serial device transmit (Tx) signal. This pin is 5.0V tolerant.

#### TX1 pin (Serial Transmit COM1):

Asynchronous Serial port COM1 transmit pin, TX1. Connect this pin to external serial device receive (Rx) signal. This pin is 5.0V tolerant. This can be configured to 1 of the GPIO pins, see table below.

#### RX1 pin (Serial Receive COM1):

Asynchronous Serial port COM1 receive pin, RX1. Connect this pin to external serial device transmit (Tx) signal. This pin is 5.0V tolerant. This can be configured to 1 of the GPIO pins, see table below.

#### TX2 pin (Serial Transmit COM2):

Asynchronous Serial port COM2 transmit pin, TX2. Connect this pin to external serial device receive (Rx) signal. This pin is 5.0V tolerant. This can be configured to 1 of the GPIO pins, see table below.

#### RX2 pin (Serial Receive COM2):

Asynchronous Serial port COM2 receive pin, RX2. Connect this pin to external serial device transmit (Tx) signal. This pin is 5.0V tolerant. This can be configured to 1 of the GPIO pins, see table below.

#### TX3 pin (Serial Transmit COM3):

Asynchronous Serial port COM3 transmit pin, TX3. Connect this pin to external serial device receive (Rx) signal. This pin is 5.0V tolerant. This can be configured to 1 of the GPIO pins, see table below.

#### RX3 pin (Serial Receive COM3):

Asynchronous Serial port COM3 receive pin, RX3. Connect this pin to external serial device transmit (Tx) signal. This pin is 5.0V tolerant. This can be configured to 1 of the GPIO pins, see table below.

### DIABLO16 Serial TTL Comm Port Configuration Options

	TX1	RX1	TX2	RX2	TX3	RX3
PA0		✓		✓		✓
PA1	✓	✓	✓	✓	✓	✓
PA2		✓		✓		✓
PA3	✓	✓	✓	✓	✓	✓
PA4	✓	✓	✓	✓	✓	✓
PA5	✓	✓	✓	✓	✓	✓
PA6	✓	✓	✓	✓	✓	✓
PA7	✓	✓	✓	✓	✓	✓
PA8	✓	✓	✓	✓	✓	✓
PA9	✓	✓	✓	✓	✓	✓
PA10		✓		✓		✓
PA11		✓		✓		✓
PA12	✓	✓	✓	✓	✓	✓
PA13	✓	✓	✓	✓	✓	✓
PA14						
PA15						

Please refer to the '*DIABLO16-4DGL-Internal-Functions.pdf*' document for information on how to set the DIABLO16 pin mappings.

### 5.4. Audio Interface

The audio support in the DIABLO16 Processor makes it better than its peers in the Graphics processor range. PWM ensures better sound quality with a volume range of 8 to 127. A simple instruction empowers the user to execute the audio files. Audio operation can be carried out simultaneously with the execution of other necessary instructions.

For a complete list of audio commands please refer to the separate document titled '*DIABLO16-4DGL-Internal-Functions.pdf*'.

#### AUDIO pin (Audio PWM output):

External Amplifier Output pin. This pin provides a 16-bit DAC/PWM audio output to use with an external audio amplifier. If unused then this pin must be left open or floating.

#### AUDENB pin (Audio Enable output):

External Amplifier enable pin. This pin provides ON/OFF amplifier control. If unused then this pin must be left open or floating.

**LOW:** Disable external Audio amplifier.

**HIGH:** Enable external Audio amplifier.

### 5.5. Touch Screen Interface

The DIABLO16 supports 4-Wire resistive touch panels. The diagram below shows a simplified interface between the DIABLO16 and a touch panel.

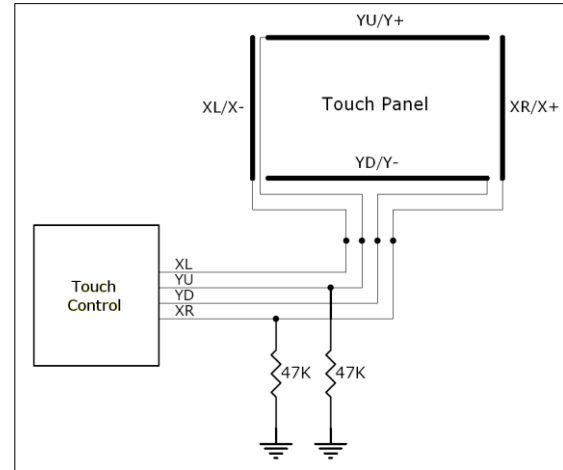

#### XR pin (Touch Panel X-Read input):

4-Wire Resistive Touch Screen X-Read analog signal. Connect this pin to XR or X+ signal of the touch panel.

#### XL pin (Touch Panel X-Drive output):

4-Wire Resistive Touch Screen X Drive signal. Connect this pin to XL or X- signal of the touch panel.

#### YU pin (Touch Panel Y-Read input):

4-Wire Resistive Touch Screen Y-Read analog signal. Connect this pin to YU or Y+ signal of the touch panel.

#### YD pin (Touch Panel Y-Drive output):

4-Wire Resistive Touch Screen Y Drive signal. Connect this pin to YD or Y- signal of the touch panel.

## 5.6. GPIO - General Purpose IO

There are 16 general purpose Input/Output (GPIO) pins available to the user. These provide flexibility of individual bit operations along with serving collectively for byte wise operations using the BUS functions

DIABLO16 Alternate Pin Configurations General Purpose I/O					
	Digital Input	Digital Output	Bus Read	Bus Write	Analog Read
PA0	✓	✓	✓	✓	✓
PA1	✓	✓	✓	✓	✓
PA2	✓	✓	✓	✓	✓
PA3	✓	✓	✓	✓	✓
PA4	✓	✓	✓	✓	
PA5	✓	✓	✓	✓	
PA6	✓	✓	✓	✓	
PA7	✓	✓	✓	✓	
PA8	✓	✓	✓	✓	
PA9	✓	✓	✓	✓	
PA10	✓	✓	✓	✓	
PA11	✓	✓	✓	✓	
PA12	✓	✓	✓	✓	
PA13	✓	✓	✓	✓	
PA14	✓		✓		
PA15	✓		✓		

Please refer to the separate document titled '*DIABLO16-4DGL-Internal-Functions.pdf*' for more information.

### PA0-PA3:

General purpose I/O pins, or can serve as Analog Input pins. Each pin can be individually set for INPUT or OUTPUT or ANALOG. Power-Up Reset default is all INPUTS. When set as Digital Inputs, the pins are 5V tolerant. Digital GPIO can source/sink 10mA. For more information see Chapter 16, 'Specifications and Ratings'.

When set as Analog Inputs, the pins have a 0 to 3.3V range, and have 12 bit resolution.

For more information, see Section 5.15 'Analog Inputs'.

### PA4-PA13:

General purpose I/O pins. Each pin can be individually set for INPUT or OUTPUT. Power-Up Reset default is all INPUTS. When set as Digital Inputs, the pins are 5V tolerant. Digital GPIO can

source/sink 10mA. For more information see Chapter 16, 'Specifications and Ratings'.

### PA14-PA15:

Input only pins. These pins can only be Digital Inputs.

**Note:** All GPIO pins are 5.0V tolerant.

## 5.7. System Pins

### VCC pins (Device Supply Voltage):

Device supply voltage pins. These pins must be connected to a regulated supply voltage in the range of 3.0 Volts to 3.6 Volts DC. Nominal operating voltage is 3.3 Volts.

### GND pins (Device Ground):

Device ground pins. These pins must be connected to system ground.

### CLK1, CLK2 pins (Device Oscillator Inputs):

CLK1 and CLK2 are the device oscillator pins. Connect a 12MHz AT strip cut crystal with 22pF capacitors from each pin to GND as shown in the diagram below.

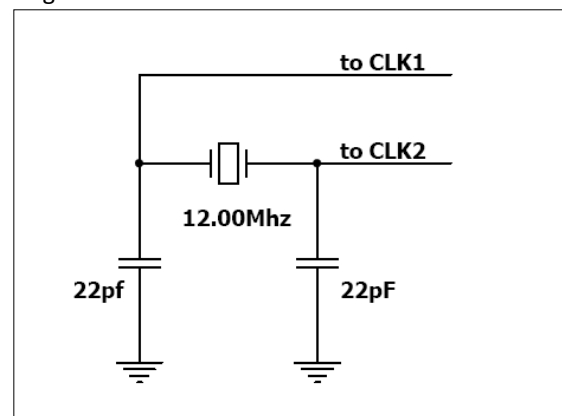

### AVCC pin (Analog Supply Voltage):

This is the analog supply voltage pin.

Option 1: This pin should be connected to VCC via a 12 ohm resistor, and also have a 4.7uF capacitor to AGND.

Option 2: Connect to VCC via an Inductor with has a resistance of less than 1ohm and a capacity greater than 10mA, along with a 4.7uF Capacitor to AGND. This option provides the best ADC noise rejection.

This is NOT an analog reference.

### AGND pin (Analog Ground):

This is the analog ground pin. This pin should be connected directly to GND

**RESET pin (Device Master Reset):**

Device Master Reset pin. An active low pulse of greater than 2 micro-seconds will reset the device. Connect a resistor (1K to 10K, nominal 4.7K) from this pin to VCC. Only use open collector type circuits to reset the device if an external reset is required. This pin is not driven low by any internal conditions.

**5.8. Alternate Pin Functions - Overview**

Most of the GPIO pins have an alternate function other than being for General Purpose I/O. GPIO pins can be configured to be SPI, I<sup>2</sup>C, Serial or a range of other functions.

**Note:** Not all pins however can be configured to be any of the alternate pin functions.

Please refer to the following tables which illustrate which pins can be associated alternative functions.

The following table illustrates which of the GPIO can be used for the four different I/O Support Functions.

DIABLO16 Alternate Pin Configurations I/O Support Functions				
	Pulse Out	PWM Out	Pin Counter	Quadrature In
PA0	✓			✓
PA1	✓			✓
PA2	✓			✓
PA3	✓			✓
PA4	✓	✓	✓	✓
PA5	✓	✓	✓	✓
PA6	✓	✓	✓	✓
PA7	✓	✓	✓	✓
PA8	✓	✓	✓	✓
PA9	✓	✓	✓	✓
PA10				✓
PA11				✓
PA12				✓
PA13				✓
PA14				
PA15				

**Note:** Once a pin is allocated to an alternate function, another pin cannot also be allocated to the same alternate function.

Please refer to the separate document titled '*DIABLO16-4DGL-Internal-Functions.pdf*' for more information on how to set the alternate pin configurations.

The Alternate pin functions have been broken up into a few tables for simplification. There are communication based functions, and I/O support based functions.

Further information is available in the next sections for each of the alternative pin functions.

**Note:** Quadrature In requires 2 Pins

The following table illustrates which of the GPIO can be used for the three different SPI channels available.

DIABLO16 Alternate Pin Configurations SPI Communications									
	SPI1 SDO	SPI1 SDI	SPI1 SCK	SPI2 SDO	SPI2 SDI	SPI2 SCK	SPI3 SDO	SPI3 SDI	SPI3 SCK
PA0		✓			✓			✓	
PA1	✓	✓	✓	✓	✓	✓	✓	✓	✓
PA2		✓			✓			✓	
PA3	✓	✓	✓	✓	✓	✓	✓	✓	✓
PA4	✓	✓	✓	✓	✓	✓	✓	✓	✓
PA5	✓	✓	✓	✓	✓	✓	✓	✓	✓
PA6	✓	✓	✓	✓	✓	✓	✓	✓	✓
PA7	✓	✓	✓	✓	✓	✓	✓	✓	✓
PA8	✓	✓	✓	✓	✓	✓	✓	✓	✓
PA9	✓	✓	✓	✓	✓	✓	✓	✓	✓
PA10		✓			✓			✓	
PA11		✓			✓			✓	
PA12	✓	✓	✓	✓	✓	✓	✓	✓	✓
PA13	✓	✓	✓	✓	✓	✓	✓	✓	✓
PA14									
PA15									

The following table illustrates which of the GPIO can be used for the three different I<sup>2</sup>C channels available.

DIABLO16 Alternate Pin Configurations I <sup>2</sup> C Communications						
	I <sup>2</sup> C1 SDA	I <sup>2</sup> C1 SCL	I <sup>2</sup> C2 SDA	I <sup>2</sup> C2 SCL	I <sup>2</sup> C3 SDA	I <sup>2</sup> C3 SCL
PA0	✓	✓	✓	✓	✓	✓
PA1	✓	✓	✓	✓	✓	✓
PA2	✓	✓	✓	✓	✓	✓
PA3	✓	✓	✓	✓	✓	✓
PA4	✓	✓	✓	✓	✓	✓
PA5	✓	✓	✓	✓	✓	✓
PA6	✓	✓	✓	✓	✓	✓
PA7	✓	✓	✓	✓	✓	✓
PA8	✓	✓	✓	✓	✓	✓
PA9	✓	✓	✓	✓	✓	✓
PA10	✓	✓	✓	✓	✓	✓
PA11	✓	✓	✓	✓	✓	✓
PA12	✓	✓	✓	✓	✓	✓
PA13	✓	✓	✓	✓	✓	✓
PA14						
PA15						

## 5.9. SPI

There are 3 user configurable SPI channels available for mapping to GPIO, for use by the user for the target application. All 3 SPI channels are Master only, and cannot be configured to be slaves at this time.

The SPI Bus speed is configurable using the **SPIx\_Init()** Function in 4DGL, and allows various speeds from 78.125Khz to 17.5Mhz.

Please refer to the table on the previous page for details on which GPIO can be configured for SPI.

**Note:** The additional SPI channel (SPI0) is dedicated to memory cards and cannot be reconfigured for alternate uses.

To map an SPI channel to a set of GPIO pins, the following 4DGL functions are used:

```
SPIx_SCK_pin(pin);    // Map the SCK pin
SPIx_SDI_pin(pin);   // Map the SDI pin
SPIx_SDO_pin(pin);   // Map the SDO pin
```

Where 'SPIx' is substituted with SPI1, SPI2 or SPI3 accordingly, and 'pin' is the target GPIO pin compatible with that particular pin function.

Chip Select for use with SPI can be any other unused GPIO pin, configured as a Digital Output. The lowering and raising of the selected CS (GPIO) pin is done manually by the user in the 4DGL application.

### Example Connection Diagram

This illustrates SPI being configured on GPIO PA4, PA6 and PA7, with user GPIO PA5 being used for the CS, and connections are to an external SPI Flash Chip.

**Note:** This example is an illustration of SPI connection to the Diablo16 processor. It is not the complete circuit nor illustrates best practice.

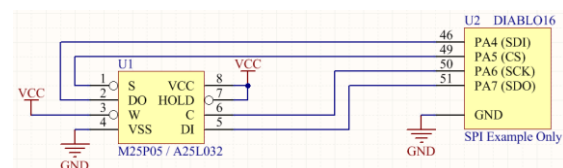

Please refer to the separate document titled '**DIABLO16-4DGL-Internal-Functions.pdf**' for more information on how to use the SPI functions.

## 5.10. I<sup>2</sup>C

There are 3 user configurable I<sup>2</sup>C channels available for mapping to GPIO, for use by the user for the target application. All 3 I<sup>2</sup>C channels are Master only, and cannot be configured to be slaves at this time.

Please refer to the table on the previous page for details on which GPIO can be configured for I<sup>2</sup>C.

To map an I<sup>2</sup>C Channel to a set of GPIO pins, the following 4DGL function is used:

```
I2Cx_Open(Speed, SCLpin, SDApin);
```

Where 'I2Cx' is substituted with I2C1, I2C2 or I2C3 accordingly, 'Speed' is the desired I2C Bus speed, and 'SCLpin' and 'SDApin' are the target GPIO pins compatible with that particular pin function.

### Example Connection Diagram

This illustrates I<sup>2</sup>C being configured on GPIO PA8 and PA9, and connections are to an external I<sup>2</sup>C Analog Input ADC.

**Note:** This example is an illustration of I<sup>2</sup>C connection to the Diablo16 processor. It is not the complete circuit nor illustrates best practice.

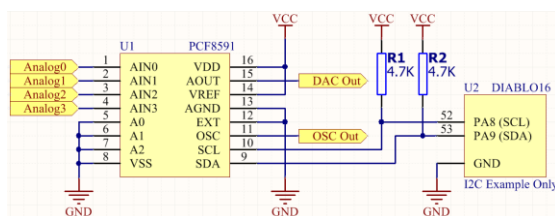

Please refer to the separate document titled '[DIABLO16-4DGL-Internal-Functions.pdf](#)' for more information on how to use the I<sup>2</sup>C functions.

## 5.11. Pulse Out

Pulse Out is used to create a single pulse of set duration on the selected pin of choice, which is inverted in polarity to the current state of the pin.

This 'inversion of polarity' means if a Pin is currently held HI, and Pulse Out is executed on that Pin, the pin will pulse LO and then return to HI. Same with vice versa, if currently LO and Pulse Out is executed on that Pin, it will pulse HI and then return to LO.

This is available in both blocking and non-blocking versions.

Please refer to the table on the previous page for details on which GPIO can be configured to this.

**Note:** Each Pulse Out request needs at least a 1ms lead time due to the scheduling of the event with the internal 1ms timer.

To enable the Pulse Out function on a GPIO pin, the following 4DGL functions are used:

```
pin_Pulseout(pin, value);           //Non-Blocking
pin_PulseoutB(pin, value);         //Blocking
```

Where 'pin' is the target GPIO pin compatible with that particular pin function, and 'value' is the length of the pulse in milliseconds.

### Example Connection Diagram

This illustrates Pulse Out being configured on GPIO PA0, and is used to open an external relay via a transistor, for an application such as opening a door lock for a set duration.

**Note:** This example is an illustration of a PulseOut connection from the Diablo16 processor. It is not the complete circuit nor illustrates best practice.

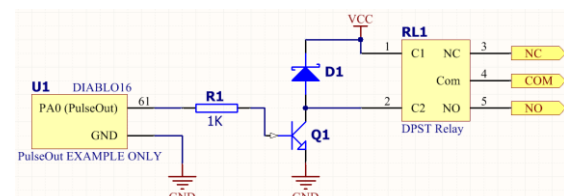

Please refer to the separate document titled '[DIABLO16-4DGL-Internal-Functions.pdf](#)' for more information on how to use the Pulse Out functions.

## 5.12. PWM Out

There are 6 PWM channels available to be configured by the user, with 4 time bases available for selection.

The PWM can be configured to be used in Servo Mode, or Simple Mode.

Please refer to the table on the previous page for details on which GPIO can be configured for PWM.

Servo Mode allows a millisecond input value with 0.01ms resolution, which runs at a frequency of approximately 50Hz or 50pps (20ms). The position of the servo is determined by the width of the pulse. Generally 1.5ms is 90 degrees, 1ms being 0 degrees and 2ms being 180 degrees. Servos however vary, and the DIABLO16 PWM control can be adjusted to suit most applications.

Simple Mode allows a percentage input value with resolution of 0.1%, which runs at a frequency of approximately 70Hz.

To enable the PWM output on a GPIO pin, the following 4DGL function is used:

**PWM\_Init(pin, mode, value);**

Where 'pin' is the GPIO compatible with the particular pin function, 'mode' is the type of PWM to generate, and 'value' is the parameter which defined the PWM pulse itself.

### Example Connection Diagram

This illustrates PWM Out being configured on GPIO PA4, and is used to open an external relay via a transistor, for an application such as dimming a lamp.

**Note:** This example is an illustration of a PWM connection from the Diablo16 processor. It is not the complete circuit nor illustrates best practice.

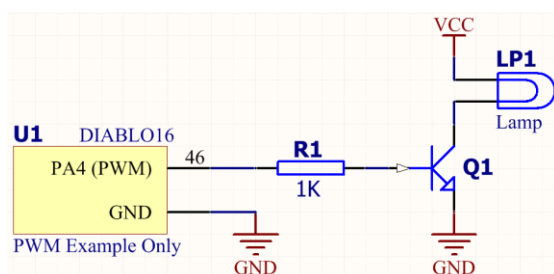

Please refer to the separate document titled '[DIABLO16-4DGL-Internal-Functions.pdf](#)' for more information on how to use the PWM functions.

## 5.13. Pin Counter

There are 6 Pin Counter channels available to be configured by the user, used to count incoming pulses with the ability to call a user function on overflow. The Pin Counter function is available for use in a variety of modes.

The counters can be read and written at any time.

Please refer to the table in section 5.8 'Alternate Pin Functions – Overview' for details on which GPIO can be configured for this.

To enable the Pin Counter function on a GPIO pin, the following 4DGL function is used:

**pin\_Counter(pin, mode, OVfunction);**

Where 'pin' is the GPIO pin compatible with this particular function, 'mode' is the type of trigger used to count on such as Rising/Falling/Edge, and 'OVfunction' is the user function to call when the counter overflows, if desired.

### Example Connection Diagram

This illustrates Pin Counter being configured on GPIO PA8, and is used to count pulses coming from a rotation sensor for example.

**Note:** This example is an illustration of a PWM connection from the Diablo16 processor. It is not the complete circuit nor illustrates best practice.

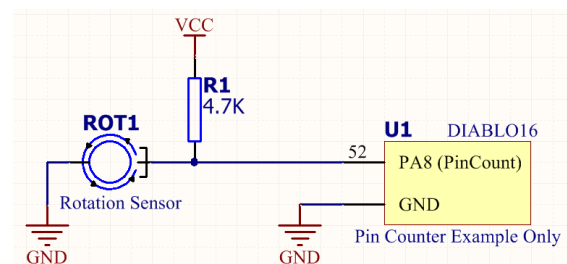

Please refer to the separate document titled '[DIABLO16-4DGL-Internal-Functions.pdf](#)' for more information on how to use the Pin Counter functions.

## 5.14. Quadrature In

There are two Quadrature Input channels available on the DIABLO16 processor, which requires 2 GPIO pins each.

Please refer to the table on the previous page for details on which GPIO can be configured for Quadrature Input.

Quadrature Input allows a quadrature encoder to be connected, and the position counter and delta counter can be read at any time.

To enable the Quadrature Input function on a set of GPIO pins (2 pins required), the following 4DGL function is used:

**Qencoderx(PHApin, PHBpin, mode);**

Where 'Qencoderx' is substituted for Qencoder1 or Qencoder2 accordingly, 'PHApin' is the pin connected to the A Phase of the Encoder, 'PHBpin' is the pin connected to the B Phase of the Encoder, and 'mode' is not currently used so is to be set to zero (0).

### Example Connection Diagram

This illustrates Quadrature input being configured on GPIO PA2 and PA3, and is used to read pulses from a quadrature encoder.

**Note:** This example is an illustration of a quadrature input connection to the Diablo16 processor. It is not the complete circuit nor illustrates best practice.

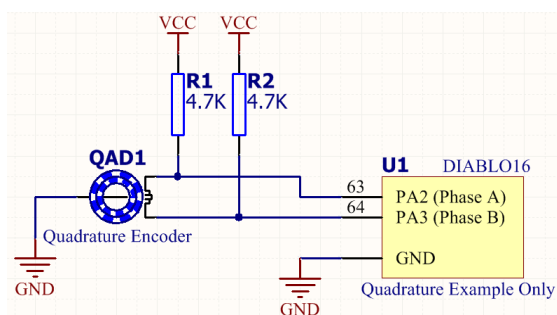

Please refer to the separate document titled '[DIABLO16-4DGL-Internal-Functions.pdf](#)' for more information on how to use the Quadrature Input functions.

## 5.15. Analog Inputs

Please refer to the table in section 5.6 for details on which GPIO can be configured to be analog inputs.

The analog inputs on the DIABLO16 have a range of 0 to 3.3V, each with a max resolution of 12-bits.

The analog inputs can be read using three modes, standard mode, averaged mode or high speed mode.

Standard Mode results in a sample being immediately read. Standard Mode can read over 40000 values per second. Operates at 12-bit.

Averaged Mode results in a 16 sample being immediately read and their average returned. Averaged Mode can read approximately 20000 values per second. Operates at 12-bit.

Highspeed Mode collects a user specified number of samples at a user specified rate/frequency and can execute a user function when complete. The updated value updates approximately 250000 times across 1-4 channels. Operates at 10-bit.

**Note:** The various analog modes can interfere with the operation of the touch screen if their functions are called too frequently. It is recommended to limit the calls of the analog functions to a maximum of once every millisecond. Please refer to the Internal Functions documentation for further information on this topic.

To enable a GPIO to be used as an Analog Input for Standard or Averaged modes, the following 4DGL function is used to set the pin:

**pin\_Set(mode, pin);**

Where 'mode' is the desired mode defined above, either Standard or Averaged, and 'pin' is the GPIO compatible with this function which is to become an Analog Input.

For highspeed mode, the following 4DGL function is used to set the pin and define the parameters:

**ana\_HS(rate, samples, 1buf, 2buf, 3buf, 4buf, func);**

Where 'rate' is the number of samples per second, 'samples' is the number of samples to collect per channel, '1buf' → '4buf' are the buffer addresses for the 4 channels, and 'func' is the user function

to call when the number of samples specified have been collected.

#### Example Connection Diagram

This illustrates an analog input being configured on GPIO PA1, and is used to read an analog temperature from a temperature sensor.

**Note:** This example is an illustration of an analog input connection to the Diablo16 processor. It is not the complete circuit nor illustrates best practice.

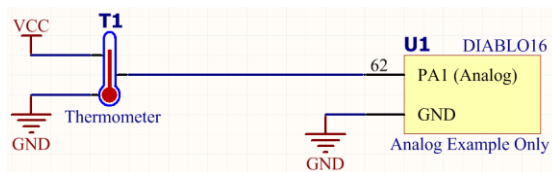

Please refer to the separate document titled '[DIABLO16-4DGL-Internal-Functions.pdf](#)' for more information on the Analog Input functions.

## 6. DIABLO16 Architecture

The figure below illustrates the DIABLO16 Processors architecture.

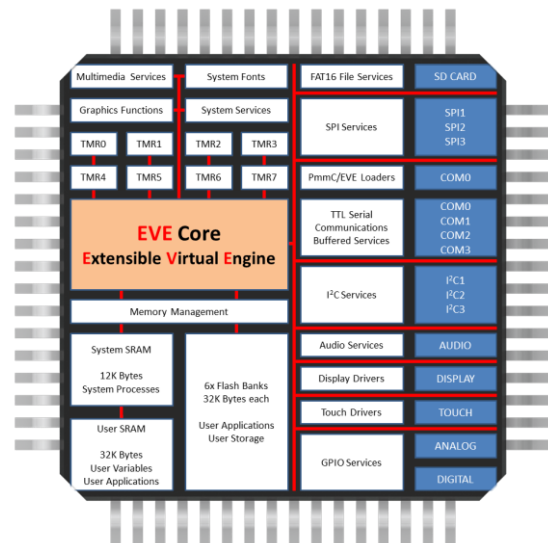

DIABLO16 is a high level graphics processor which runs the high level 4DGL (4D Graphics Language).

It is not a conventional microcontroller with conventional microcontroller architecture, it is a custom graphics processor and therefore low level access to the chip is not required nor available to the User.

4DGL provides high level functions for the User and does all the low level work in the background in a highly optimised fashion.

## 6.1. FLASH Storage and RAM allocation

The figure below illustrates how the FLASH and RAM are allocated in the System, and what is available for use by the system and by the user. Each area is explained in the sections following.

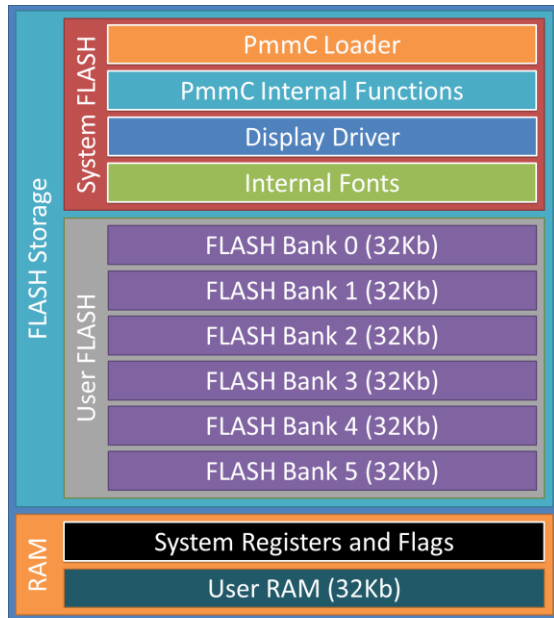

Loading of the PmmC, Display Driver and User Applications into their various places on the DIABLO16 processor, is achieved using the Workshop4 IDE.

If a script for batch loading of the PmmC, Display Driver and/or User Applications without the use of the Workshop4 is required, there is a script utility available.

Please refer to the Application Notes section of the 4D Systems website for information on this process.

## 6.2. PmmC Loader + Internal Functions

PmmC (Personality Module Micro-Code) - this is the operating system, incorporating the EVE runtime (Extensible Virtual Engine) which has an extensive byte-code instruction set programmed via the Workshop4 Software IDE.

The PmmC Loader can be thought of like a bootloader, and allows the transfer of a PmmC from the Users' PC into the System Flash storage on the DIABLO16 processor.

Within the PmmC are over 450 built in functions for graphics, sound, math functions etc, no need

to include libraries, or wait for hefty compile times – it's all built in.

The PmmC is in protected memory, and cannot be read or damaged by inadvertent writes to illegal FLASH areas.

The PmmC may be upgraded at any time without disturbing any programs that may already exist in the 6 FLASH banks.

## 6.3. Display Driver

The DIABLO16 is capable of interfacing with many different types of display devices. The DIABLO16 has been designed more the maximum flexibility possible and therefore the Display Driver is modular, and replaceable, and separate from the PmmC.

The Display Driver may be upgraded at any time without disturbing any applications or data which may exist in the 6 FLASH banks, or the PmmC.

## 6.4. User FLASH Memory Banks

The DIABLO16 processor has 6 banks (Bank0 to Bank5) of Flash memory which can be utilised by the user to store application code or data, to be used by the display or stored for sending to an external device over comms.

Each of the 6 banks is 32750 bytes in size, which provides over 12x the Flash capacity of the PICASO processor.

When a user's application is written to the Flash of the DIABLO16 from the Workshop4 IDE Software, the user is able to choose the destination bank for the application to be stored in.

Bank0 is always the bank which is loaded on start-up of the DIABLO16. The bank0 application can then transfer control over to one of the other banks, and the application stored in there will then run. This is achieved using the 4DGL **flash\_Run()** function. Applications can freely change banks as required using this function, however a separate application (or Data) is required to reside in each bank, a single application cannot take up more than 1 bank itself. When an application from another bank is run using the **flash\_Run()** function, the processor is restarted and the execution from the other bank is started.

An application in one bank can store data in another bank using 4DGL commands such as:

### flash\_Copy() flash\_WriteBlock()

An application in one bank can store applications from microSD card and writing them to a bank for future execution using the 4DGL function **flash\_LoadFile()**

An application in one bank can read data stored in another bank, such as graphics or strings stored there, and retrieve them and display them as required. Reading of data from another bank is achieved using 4DGL functions such as:

**flash\_GetByte()**  
**flash\_GetWord()**  
**flash\_putstr()**  
**flash\_Blit2()**  
**flash\_Blit4()**  
**flash\_Blit8()**  
**flash\_Blit16()**

An application in a bank can erase other banks if required, and can also erase itself which essentially formats the processor. Erasing of a bank is achieved in 4DGL using the **flash\_EraseBank()** function.

**Note:** The **flash\_EraseBank()** function should be used with caution as it will permanently erase any applications and/or data stored on that bank.

Please refer to the separate document titled '**DIABLO16-4DGL-Internal-Functions.pdf**' for more information on how to read/write/erase/access and change between FLASH banks.

## 6.5. RAM (Both System and User)

The DIABLO16 processor has two banks of RAM, one is 32kb of User RAM, and the other is a much smaller bank of System RAM which is only usable by the system, for its internal processes.

The System RAM is reserved for the system and is not accessible by the user. It is used for processes such as Audio Buffer, Intermediate File Buffers, Graphics Rendering, etc. This RAM ensures the users RAM is not taken by the system.

No matter what options are enabled by the system, or by the user to influence the system (such as the size of the audio buffer), the system will never run out of RAM and try to encroach into the users RAM space.

The DIABLO16's 32768 (32kb) of User RAM is used to store variables and for user applications, sub programs etc. Sub programs and Functions stored in RAM can be released when no longer required, freeing the memory for the user.

The user has full access to this 32kb of User RAM, and all internal processes of the DIABLO16 utilise only the separate System RAM.

## 7. 4DGL - Software Language

The DIABLO16 processor belongs to a family of processors powered by a highly optimised soft core virtual engine, EVE (Extensible Virtual Engine).

EVE is a proprietary, high performance virtual-machine with an extensive byte-code instruction set optimised to execute compiled 4DGL programs. 4DGL (4D Graphics Language) was specifically developed from ground up for the EVE engine core. It is a high level language which is easy to learn and simple to understand yet powerful enough to tackle many embedded graphics applications.

4DGL is a graphics oriented language allowing rapid application development, and the syntax structure was designed using elements of popular languages such as C, Basic, Pascal and others.

Programmers familiar with these languages will feel right at home with 4DGL. It includes many familiar instructions such as IF..ELSE..ENDIF, WHILE..WEND, REPEAT..UNTIL, GOSUB..ENDSUB, GOTO, PRINT as well as some specialised instructions SERIN, SEROUT, GFX\_LINE, GFX\_CIRCLE and many more.

For detailed information pertaining to the 4DGL language, please refer to the following documents:  
**"4DGL-Programmers-Reference-Manual.pdf"**  
**"DIABLO16-4DGL-Internal-Functions.pdf"**

To assist with the development of 4DGL applications, the Workshop 4 IDE combines a full-featured editor, a compiler, a linker and a downloader into a single PC-based application. It's all you need to code, test and run your applications.

## 8. In Circuit Serial Programming ICSP

The DIABLO16 processor is a custom graphics processor. All functionality including the high level commands are built into the chip. This chip level configuration is available as a PmmC (Personality-module-micro-Code) file, which can be likened to traditional Firmware. There is also a Display Driver file, which separates specific display settings from the PmmC, unlike on the PICASO processor where everything is combined.

A PmmC file contains all of the low level micro-code information (analogy of that of a soft silicon) which define the characteristics and functionality of the device. The ability of programming the device with a PmmC file provides an extremely flexible method of customising as well as upgrading it with future enhancements.

The Display Driver contains the initialisation and parameters associated with the particular display that is to be connected to the DIABLO16 processor.

The PmmC file and Display Driver file can only be programmed into the device via the COM0 serial port and an access to this must be provided for on the target application board. This is referred to as In Circuit Serial Programming (ICSP).

The PmmC file and Display Driver file are programmed into the device with the aid of Workshop 4, the 4D Systems IDE software (See Section 12). To provide a link between the PC and the ICSP interface, a specific 4D Programming Cable or adaptor is required and is available from 4D Systems.

Using a non-4D programming interface could damage your processor, and **void your Warranty.**

**Note:** The DIABLO16 processor is shipped blank and it must be programmed with both the PmmC configuration and Display Driver files.

## 9. System Registers Memory Map

The following tables outline in detail the DIABLO16 system registers and flags.

DIABLO16 System Registers and Flags			
LABEL	ADDRESS		USAGE
	DEC	HEX	
RANDOM_LO	32	0x20	random number generator LO word
RANDOM_HI	33	0x21	random number generator HI word
SYSTEM_TIMER_LO	34	0x22	1msec 32 bit free running timer LO word
SYSTEM_TIMER_HI	35	0x23	1msec 32 bit free running timer HI word
TIMER0	36	0x24	1msec user timer 0
TIMER1	37	0x25	1msec user timer 1
TIMER2	38	0x26	1msec user timer 2
TIMER3	39	0x27	1msec user timer 3
TIMER4	40	0x28	1msec user timer 4
TIMER5	41	0x29	1msec user timer 5
TIMER6	42	0x2A	1msec user timer 6
TIMER7	43	0x2B	1msec user timer 7
SYS_X_MAX	44	0x2C	display hardware X res-1
SYS_Y_MAX	45	0x2D	display hardware Y res-1
GFX_XMAX	46	0x2E	current display width-1 determined by portrait / landscape swapping
GFX_YMAX	47	0x2F	current display height-1 determined by portrait / landscape swapping
GFX_LEFT	48	0x30	virtual left point for most recent object
GFX_TOP	49	0x31	virtual top point for most recent object
GFX_RIGHT	50	0x32	virtual right point for most recent object
GFX_BOTTOM	51	0x33	virtual bottom point for most recent object
GFX_X1	52	0x34	clipped left point for current object
GFX_Y1	53	0x35	clipped top point for current object
GFX_X2	54	0x36	clipped right point for current object
GFX_Y2	55	0x37	clipped bottom point for current object
GFX_X_ORG	56	0x38	current X origin
GFX_Y_ORG	57	0x39	current Y origin
GFX_THUMB_PERCENT	75	0x4B	size of slider thumb as percentage
GFX_THUMB_BORDER_DARK	76	0x4C	darker shadow of thumb
GFX_THUMB_BORDER_LIGHT	77	0x4D	lighter shadow of thumb
TOUCH_XMINCAL	78	0x4E	touch calibration value
TOUCH_YMINCAL	79	0x4F	touch calibration value
TOUCH_XMAXCAL	80	0x50	touch calibration value
TOUCH_YMAXCAL	81	0x51	touch calibration value
IMG_WIDTH	82	0x52	width of currently loaded image
IMG_HEIGHT	83	0x53	height of currently loaded image
IMG_FRAME_DELAY	84	0x54	if image, else inter frame delay for movie
IMG_FLAGS	85	0x55	bit 4 determines colour mode, other bits reserved
IMG_FRAME_COUNT	86	0x56	count of frames in a movie
IMG_PIXEL_COUNT_LO	87	0x57	count of pixels in the current frame
IMG_PIXEL_COUNT_HI	88	0x58	count of pixels in the current frame
IMG_CURRENT_FRAME	89	0x59	last frame shown
MEDIA_ADDRESS_LO	90	0x5A	micro-SD byte address LO
MEDIA_ADDRESS_HI	91	0x5B	micro-SD byte address HI
MEDIA_SECTOR_LO	92	0x5C	micro-SD sector address LO

**NOTE:** These registers are accessible with [peekW](#) and [pokeW](#) functions.

## DIABLO16 System Registers and Flags (continued...)

LABEL	ADDRESS		USAGE
	DEC	HEX	
MEDIA_SECTOR_HI	93	0x5D	micro-SD sector address HI
MEDIA_SECTOR_COUNT	94	0x5E	micro-SD number of bytes remaining in sector
TEXT_XPOS	95	0x5F	text current x pixel position
TEXT_YPOS	96	0x60	text current y pixel position
TEXT_MARGIN	97	0x61	text left pixel pos for carriage return
TXT_FONT_ID	98	0x62	font type, 0 = system font, else pointer to user font
TXT_FONT_MAX	99	0x63	max number of chars in font
TXT_FONT_OFFSET	100	0x64	starting offset (normally 0x20)
TXT_FONT_WIDTH	101	0x65	current font width
TXT_FONT_HEIGHT	102	0x66	Current font height
GFX_TOUCH_REGION_X1	103	0x67	touch capture region
GFX_TOUCH_REGION_Y	104	0x68	
GFX_TOUCH_REGION_X2	105	0x69	
GFX_TOUCH_REGION_Y2	106	0x6A	
GFX_CLIP_LEFT_VAL	107	0x6B	left clipping point (set with gfx_ClipWindow(...))
GFX_CLIP_TOP_VAL	108	0x6C	top clipping point (set with gfx_ClipWindow(...))
GFX_CLIP_RIGHT_VAL	109	0x6D	right clipping point (set with gfx_ClipWindow(...))
GFX_CLIP_BOTTOM_VAL	110	0x6E	bottom clipping point (set with gfx_ClipWindow(...))
GFX_CLIP_LEFT	111	0x6F	current clip value (reads full size if clipping turned off)
GFX_CLIP_TOP	112	0x70	current clip value (reads full size if clipping turned off)
GFX_CLIP_RIGHT	113	0x71	current clip value (reads full size if clipping turned off)
GFX_CLIP_BOTTOM	114	0x72	current clip value (reads full size if clipping turned off)
GRAM_PIXEL_COUNT_LO	115	0x73	LO word of count of pixels in the set GRAM area
GRAM_PIXEL_COUNT_HI	116	0x74	HI word of count of pixels in the set GRAM area
TOUCH_RAW_X	117	0x75	12 bit raw A2D X value from touch screen
TOUCH_RAW_Y	118	0x76	12 bit raw A2D Y value from touch screen
GFX_LAST_CHAR_WIDTH	119	0x77	calculated char width from last call to charWidth function
GFX_LAST_CHAR_HEIGHT	120	0x78	calculated height from last call to charHeight function
GFX_LAST_STR_WIDTH	121	0x79	calculated width from last call to strWidth function
GFX_LAST_STR_HEIGHT	122	0x7A	calculated height from last call to strHeight function
PIN_COUNTER_PA4	123	0x7B	pin counter for PA4
PIN_COUNTER_PA5	124	0x7C	pin counter for PA5
PIN_COUNTER_PA6	125	0x7D	pin counter for PA6
PIN_COUNTER_PA7	126	0x7E	pin counter for PA7
PIN_COUNTER_PA8	127	0x7F	pin counter for PA8
PIN_COUNTER_PA9	128	0x80	pin counter for PA9
PIN_EVENT_PA4	129	0x81	pin counter rollover event for PA4
PIN_EVENT_PA5	130	0x82	pin counter rollover event for PA5
PIN_EVENT_PA6	131	0x83	pin counter rollover event for PA6
PIN_EVENT_PA7	132	0x84	pin counter rollover event for PA7
PIN_EVENT_PA8	133	0x85	pin counter rollover event for PA8
PIN_EVENT_PA9	134	0x86	pin counter rollover event for PA9
QEN1_COUNTER_LO	135	0x87	quadrature encoder #1 counter LO
QEN1_COUNTER_HI	136	0x88	quadrature encoder #1 counter HI
QEN1_DELTA	137	0x89	quadrature encoder #1 delta count
QEN2_COUNTER_LO	138	0x8A	quadrature encoder #2 counter LO
QEN2_COUNTER_HI	139	0x8B	quadrature encoder #2 counter HI
QEN2_DELTA	140	0x8C	quadrature encoder #2 delta count
FALSE_REASON	141	0x8D	explanation 'false' results, currently only for flash_ functions

**NOTE:** These registers are accessible with [peekW](#) and [pokeW](#) functions.

## 10. Memory Cards - FAT16 Format

The DIABLO16 Processor uses off the shelf standard SDHC/micro-SD memory cards with up to 2GB capacity usable with FAT16 formatting. For any FAT file related operations, before the memory card can be used it must first be formatted with FAT16 option. The formatting of the card can be done on any PC system with a card reader. Select the appropriate drive and choose the FAT16 (or just FAT in some systems) option when formatting. The card is now ready to be used in the DIABLO16 based application.



The DIABLO16 Processor also supports high capacity HC memory cards (4GB and above). The available capacity of SD-HC cards varies according to the way the card is partitioned and the commands used to access it.



The FAT partition is always first (if it exists) and can be up to the maximum size permitted by FAT16. Windows 7 will format FAT16 up to 4GB. Windows XP will format FAT16 up to 2GB and the Windows XP command prompt will format FAT16 up to 4GB.

## 11. Hardware Tools

The following hardware tools are required for full control of the DIABLO16 Processor.

### 11.1. 4D Programming Cable & Adaptor

The 4D Programming Cable and uUSB-PA5 Programming Adaptors are essential hardware tools to program, customise and test the DIABLO16 Processor.

Either the 4D Programming Cable or the uUSB-PA5 Programming Adaptor can be used.

The 4D programming interfaces are used to program a new Firmware/PmmC, Display Driver and for downloading compiled 4DGL code into the processor. They even serve as an interface for communicating serial data to the PC.

The 4D Programming Cable and uUSB-PA5 Programming Adaptor are available from 4D Systems, [www.4dsystems.com.au](http://www.4dsystems.com.au)

Using a non-4D programming interface could damage your processor, and **void your Warranty.**



4D Programming Cable



uUSB-PA5 Programming Adaptor

## 11.2. Evaluation Display Modules

The following modules, available from 4D Systems, can be used for evaluation purposes to discover what the DIABLO16 processor has to offer.

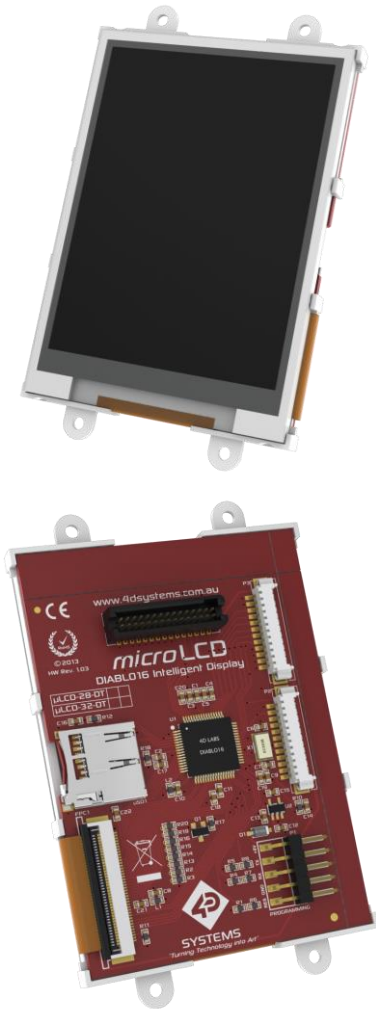

uLCD-32DT – 3.2” Intelligent DIABLO16 Display

Other modules, such as the 2.8” version are also available. Please contact 4D Systems for more information, or visit the 4D Systems website, [www.4dsystems.com.au](http://www.4dsystems.com.au)

## 12. 4D Systems - Workshop 4 IDE

Workshop4 is a comprehensive software IDE that provides an integrated software development platform for all of the 4D family of processors and modules. The IDE combines the Editor, Compiler, Linker and Downloader to develop complete 4DGL application code. All user application code is developed within the Workshop 4 IDE.



The Workshop 4 IDE supports multiple development environments for the user, to cater for different user requirements and skill level.

- The **Designer** environment enables the user to write 4DGL code in its natural form to program the 4D processor of choice.
- A visual programming experience, suitably called **ViSi**, enables drag-and-drop type placement of objects to assist with 4DGL code generation and allows the user to visualise how the display will look while being developed.
- An advanced environment called **ViSi-Genie** doesn't require any 4DGL coding at all, it is all done automatically for you. Simply lay the display out with the objects you want, set the events to drive them and the code is written for you automatically. ViSi-Genie provides the latest rapid development experience from 4D Systems.

The Workshop 4 IDE is available from the 4D Systems website. [www.4dsystems.com.au](http://www.4dsystems.com.au)

For a comprehensive manual on the Workshop 4 IDE Software along with other documents, refer to the documentation from the 4D Systems website, on the Workshop 4 product page.

**12.1. Workshop 4 – Designer Environment**

Choose the Designer environment to write 4DGL code in its raw form.

The Designer environment provides the user with a simple yet effective programming environment where pure 4DGL code can be written, compiled and downloaded to the DIABLO16.

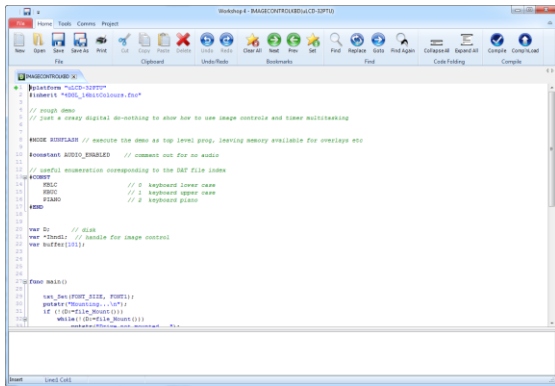

**12.2. Workshop 4 – ViSi Environment**

ViSi was designed to make the creation of graphical displays a more visual experience.

ViSi is a great software tool that allows the user to see the instant results of their desired graphical layout. Additionally, there is a selection of inbuilt dials, gauges and meters that can simply be placed onto the simulated module display. From here each object can have its properties edited, and at the click of a button all relevant 4DGL code associated with that object is produced in the user program. The user can then write 4DGL code around these objects to utilise them in the way they choose.

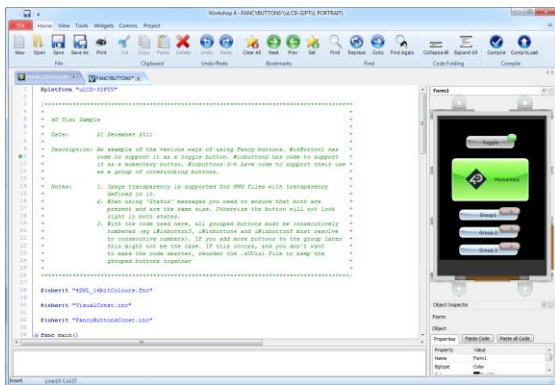

**12.3. Workshop 4 – ViSi Genie Environment**

ViSi Genie is a breakthrough in the way 4D Systems' graphic display modules are programmed. It is an environment like no other, a code-less programming environment that provides the user with a rapid visual experience, enabling a simple GUI application to be 'written' from scratch in literally seconds.

ViSi Genie does all the background coding, no 4DGL to learn, it does it all for you.

Pick and choose the relevant objects to place on the display, much like the ViSi Environment, yet without having to write a single line of code. Each object has parameters which can be set, and configurable events to animate and drive other objects or communicate with external devices.

Simply place an object on the screen, position and size it to suit, set the parameters such as colour, range, text, and finally select the event you wish the object to be associated with, it is that simple.

In seconds you can transform a blank display into a fully animated GUI with moving sliders, animated press and release buttons, and much more. All without writing a single line of code!

ViSi Genie provides the user with a feature rich rapid development environment, second to none.

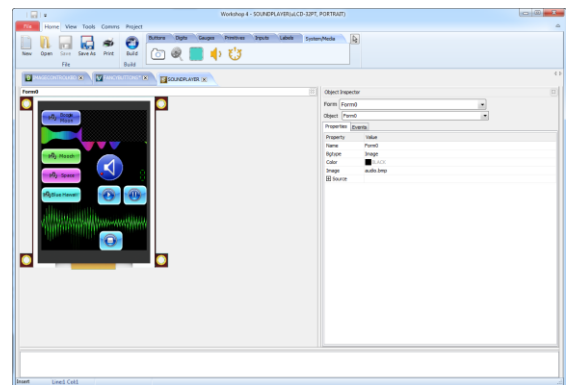

13. Reference Design

DIABLO16 PROCESSOR

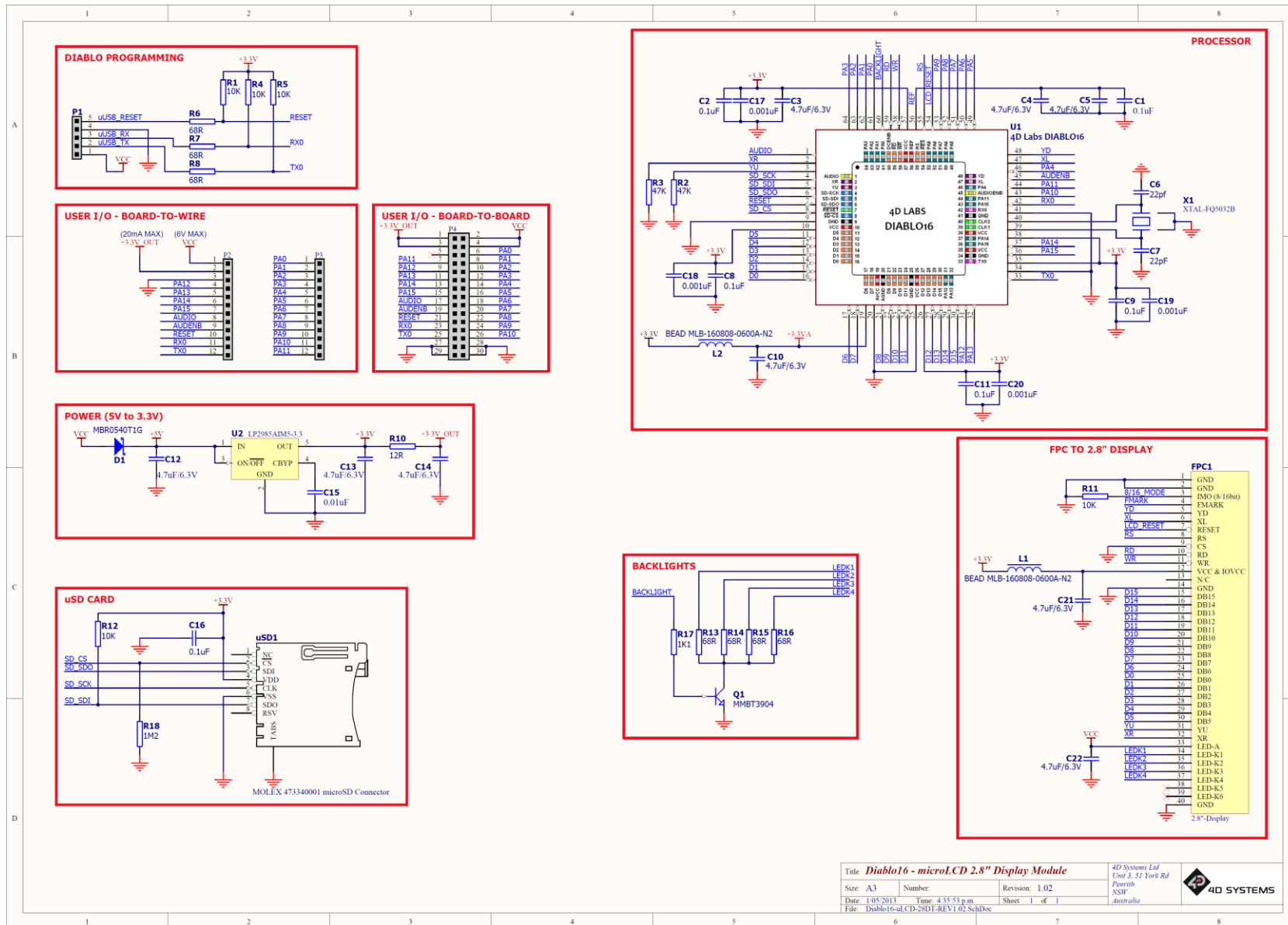

Title: <b>Diablo16 - microLCD 2.8" Display Module</b>		4D Systems Ltd Unit 3, 51 York Rd Perth NSW Australia	
Size: A3	Number:	Revision: 1.02	
Date: 1.05.2013	Time: 4:35:53 p.m.	Sheet 1 of 1	
File: Diablo16-uLCD-28DI-REV1.02_SchDoc			

## 14. Package Details

### 64-Lead Plastic Thin Quad Flatpack (PT) – 10x10x1 mm Body, 2.00 mm [TQFP]

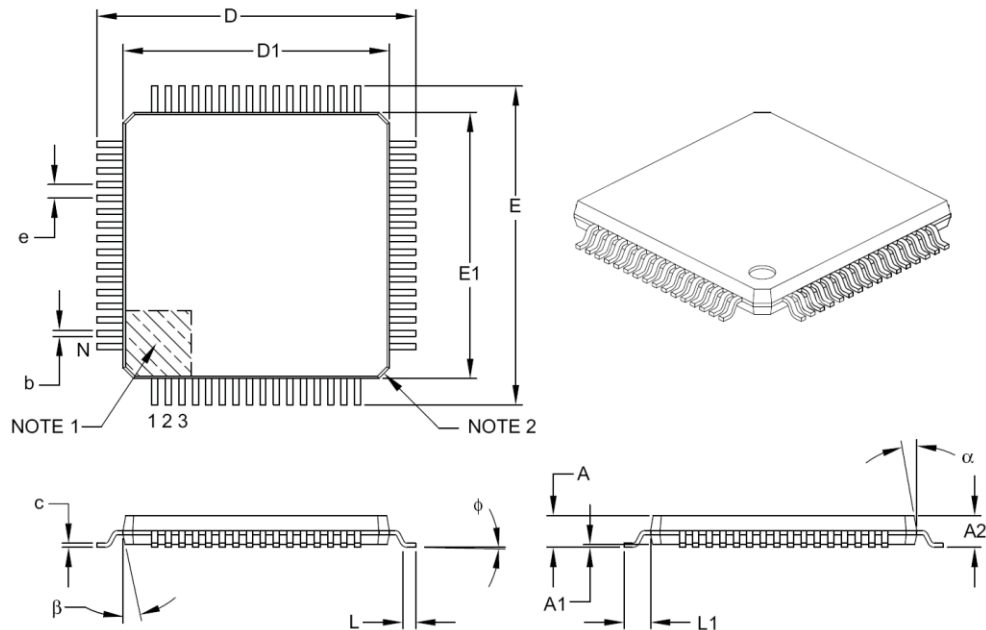

Dimension Limits	Units	MILLIMETERS		
		MIN	NOM	MAX
Number of Leads	N	64		
Lead Pitch	e	0.50 BSC		
Overall Height	A	–	–	1.20
Molded Package Thickness	A2	0.95	1.00	1.05
Standoff	A1	0.05	–	0.15
Foot Length	L	0.45	0.60	0.75
Footprint	L1	1.00 REF		
Foot Angle	$\phi$	0°	3.5°	7°
Overall Width	E	12.00 BSC		
Overall Length	D	12.00 BSC		
Molded Package Width	E1	10.00 BSC		
Molded Package Length	D1	10.00 BSC		
Lead Thickness	c	0.09	–	0.20
Lead Width	b	0.17	0.22	0.27
Mold Draft Angle Top	$\alpha$	11°	12°	13°
Mold Draft Angle Bottom	$\beta$	11°	12°	13°

#### Notes:

- Pin 1 visual index feature may vary, but must be located within the hatched area.
- Chamfers at corners are optional; size may vary.
- Dimensions D1 and E1 do not include mold flash or protrusions. Mold flash or protrusions shall not exceed 0.25 mm per side.
- Dimensioning and tolerancing per ASME Y14.5M.

BSC: Basic Dimension. Theoretically exact value shown without tolerances.

REF: Reference Dimension, usually without tolerance, for information purposes only.

**15. PCB Land Pattern**

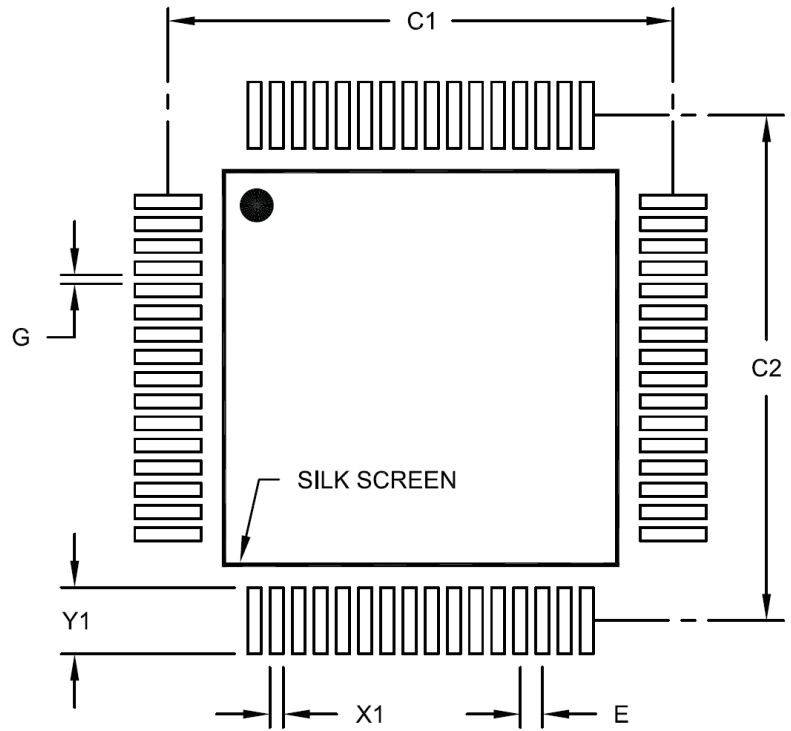

RECOMMENDED LAND PATTERN

Dimension Limits	Units	MILLIMETERS		
		MIN	NOM	MAX
Contact Pitch	E	0.50 BSC		
Contact Pad Spacing	C1		11.40	
Contact Pad Spacing	C2		11.40	
Contact Pad Width (X64)	X1			0.30
Contact Pad Length (X64)	Y1			1.50
Distance Between Pads	G	0.20		

Notes:

1. Dimensioning and tolerancing per ASME Y14.5M

BSC: Basic Dimension. Theoretically exact value shown without tolerances.

## 16. Specifications and Ratings

### ABSOLUTE MAXIMUM RATINGS

Operating ambient temperature .....	-40°C to +85°C
Storage temperature .....	-65°C +150°C
Voltage on VCC with respect to GND .....	-0.3V to 4.0V
Maximum current out of GND pin .....	320mA
Maximum current into VCC pin .....	320mA
Maximum current sunk/sourced by any pin .....	10.0mA
Maximum current sunk/sourced by all ports .....	200.0mA
Total power dissipation .....	1.0W + I/O Load

**NOTE:** Stresses above those listed here may cause permanent damage to the device. This is a stress rating only and functional operation of the device at those or any other conditions above those indicated in the recommended operation listings of this specification is not implied. Exposure to maximum rating conditions for extended periods may affect device reliability.

### RECOMMENDED OPERATING CONDITIONS

Parameter	Conditions	Min	Typ	Max	Units
Supply Voltage (VCC)		3.0	3.3	3.6	V
Operating Temperature		-40	--	+80	°C
External Crystal (Xtal)		--	12.00	--	Mhz
Input Low Voltage (VIL)	VCC = 3.3V, all pins	VGND	--	0.2VCC	V
Input High Voltage (VIH)	VCC = 3.3V, non 5V tolerant pins	0.8VCC	--	VCC	V
Input High Voltage (VIH)	All GPIO pins, RX0 and TX0 pins	0.8VCC	--	5.5	V

### GLOBAL CHARACTERISTICS BASED ON OPERATING CONDITIONS

Parameter	Conditions	Min	Typ	Max	Units
Supply Current (ICC)	VCC = 3.3V	--	70	--	mA
Internal Operating Frequency	Xtal = 12.00Mhz	--	70.00	--	Mhz
Output Low Voltage (VOL)	VCC = 3.3V, IOL ≤ 10mA	--	--	0.4	V
Output High Voltage (VOH)	VCC = 3.3V, IOL ≥ -10.0mA	2.4	--	--	V
A/D Converter Resolution	PA0-PA3, XR, YU pins	--	--	12	bits
Capacitive Loading	CLK1, CLK2 pins	--	--	15	pF
Capacitive Loading	All other pins	--	--	50	pF
Flash Memory Endurance	Programming	--	10000	--	E/W

### ORDERING INFORMATION

**Order Code:** DIABLO16

**Package:** TQFP-64, 10mm x 10mm

**Packaging:** Trays of 160 pieces

## 17. Legal Notice

### Proprietary Information

The information contained in this document is the property of 4D Systems Pty. Ltd. and may be the subject of patents pending or granted, and must not be copied or disclosed without prior written permission.

4D Systems endeavours to ensure that the information in this document is correct and fairly stated but does not accept liability for any error or omission. The development of 4D Systems products and services is continuous and published information may not be up to date. It is important to check the current position with 4D Systems. 4D Systems reserves the right to modify, update or make changes to Specifications or written material without prior notice at any time.

All trademarks belong to their respective owners and are recognised and acknowledged.

### Disclaimer of Warranties & Limitation of Liability

4D Systems makes no warranty, either expressed or implied with respect to any product, and specifically disclaims all other warranties, including, without limitation, warranties for merchantability, non-infringement and fitness for any particular purpose.

Information contained in this publication regarding device applications and the like is provided only for your convenience and may be superseded by updates. It is your responsibility to ensure that your application meets with your specifications.

In no event shall 4D Systems be liable to the buyer or to any third party for any indirect, incidental, special, consequential, punitive or exemplary damages (including without limitation lost profits, lost savings, or loss of business opportunity) arising out of or relating to any product or service provided or to be provided by 4D Systems, or the use or inability to use the same, even if 4D Systems has been advised of the possibility of such damages.

4D Systems products are not fault tolerant nor designed, manufactured or intended for use or resale as on line control equipment in hazardous environments requiring fail – safe performance, such as in the operation of nuclear facilities, aircraft navigation or communication systems, air traffic control, direct life support machines or weapons systems in which the failure of the product could lead directly to death, personal injury or severe physical or environmental damage ('High Risk Activities'). 4D Systems and its suppliers specifically disclaim any expressed or implied warranty of fitness for High Risk Activities.

Use of 4D Systems' products and devices in 'High Risk Activities' and in any other application is entirely at the buyer's risk, and the buyer agrees to defend, indemnify and hold harmless 4D Systems from any and all damages, claims, suits, or expenses resulting from such use. No licenses are conveyed, implicitly or otherwise, under any 4D Systems intellectual property rights.

## 18. Contact Information

For Technical Support: [support@4dsystems.com.au](mailto:support@4dsystems.com.au)

For Sales Support: [sales@4dsystems.com.au](mailto:sales@4dsystems.com.au)

Website: [www.4dsystems.com.au](http://www.4dsystems.com.au)

**Copyright 4D Systems Pty. Ltd. 2000-2013.**

# Mouser Electronics

Authorized Distributor

Click to View Pricing, Inventory, Delivery & Lifecycle Information:

[4D Systems:](#)

[DIABLO-16](#)