

Hall Effect Current Sensors L08P***D15 Series



Features:

- Open Loop type
- Printed circuit board mounting
- 5 pin PCB connection
- Bipolar power supply
- Insulated plastic case according to UL94V0

Advantage:

- Excellent accuracy
- Very good linearity
- Low temperature drift
- No insertion loss
- High Immunity To External Interference
- Current overload capability

Specifications

$T_A=25^{\circ}\text{C}$, $V_{CC}=\pm 15\text{V}$, $R_L=10\text{k}\Omega$

Parameters	Symbol	L08P050D15	L08P100D15	L08P150D15	L08P200D15
Nominal Primary DC current	I_f	50AT	100AT	150AT	200AT
Maximum Current	I_{fmax}	$\pm 150\text{AT}$	$\pm 300\text{AT}$	$\pm 450\text{AT}$	$\pm 500\text{AT}$
Output Voltage	V_{OUT}	$4\text{V} \pm 0.040\text{V} @ \pm I_f$			
Offset Voltage	V_{OE}	$< \pm 30\text{mV} @ I_f = 0\text{A}$			
Accuracy ¹	X	$\pm 1\% @ I_f$			
Output Linearity ¹	ϵ_L	$\leq \pm 1\% @ I_f$			
Power Supply	V_{CC}	$\pm 15\text{V} \pm 5\%$			
Consumption Current	I_c	$\leq 12\text{mA}$			
Response Time ²	t_r	$\leq 10\mu\text{s} (@ di/dt = 50\text{A} / \mu\text{s})$			
Output Temperature Characteristic ¹	TCV_{OUT}	$< \pm 2\text{mV}/^{\circ}\text{C}$	$< \pm 1\text{mV}/^{\circ}\text{C}$		
Offset Temperature Characteristic	TCV_{OE}	$< \pm 2\text{mV}/^{\circ}\text{C}$	$< \pm 1\text{mV}/^{\circ}\text{C}$		
Hysteresis error	V_{OH}	$\leq 30\text{mV} (0\text{A} \leftrightarrow I_f)$	$\leq 20\text{mV} (0\text{A} \leftrightarrow I_f)$		
Withstand Voltage	V_d	AC2500V for 1minute (sensing current 0.5mA), inside of through hole \leftrightarrow terminal			
Insulation Resistance	R_{IS}	$> 500\text{M}\Omega$ (500V DC), inside of through hole \leftrightarrow terminal			
Frequency Bandwidth ³	f	DC .. 35kHz			
Operating Temperature	T_A	$-10^{\circ}\text{C} \sim +80^{\circ}\text{C}$			
Storage Temperature	T_s	$-20^{\circ}\text{C} \sim +85^{\circ}\text{C}$			

¹ Without offset — ² Time between 10% input current full scale and 90% of sensor output full scale — ³ Small signal only to avoid excessive heating of magnetic core

Electrical Performances

Frequency Characteristic (L08P200D15)

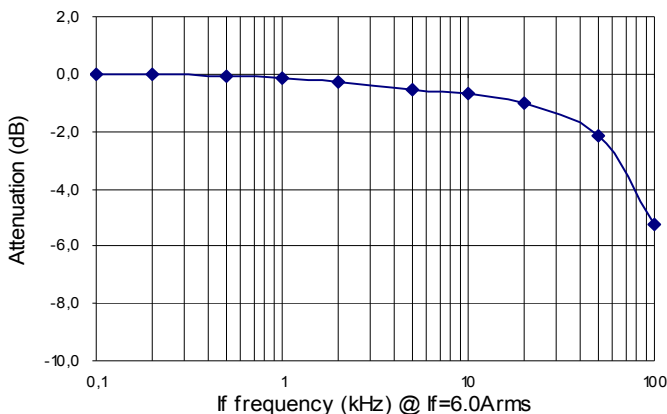

Saturation Characteristic (L08P200D15)

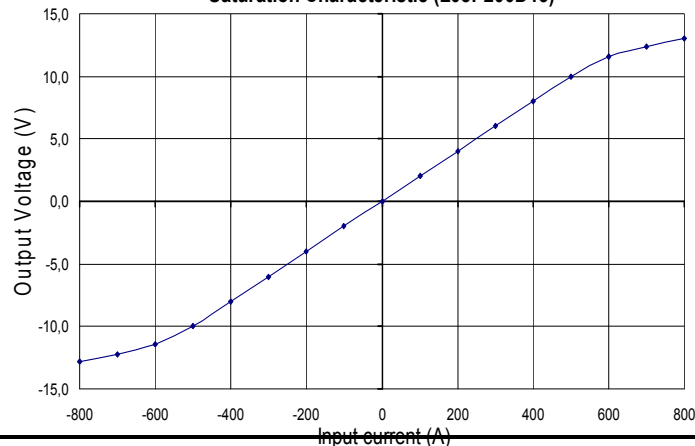

Hall Effect Current Sensors L08P***D15 Series

Mechanical dimensions in mm

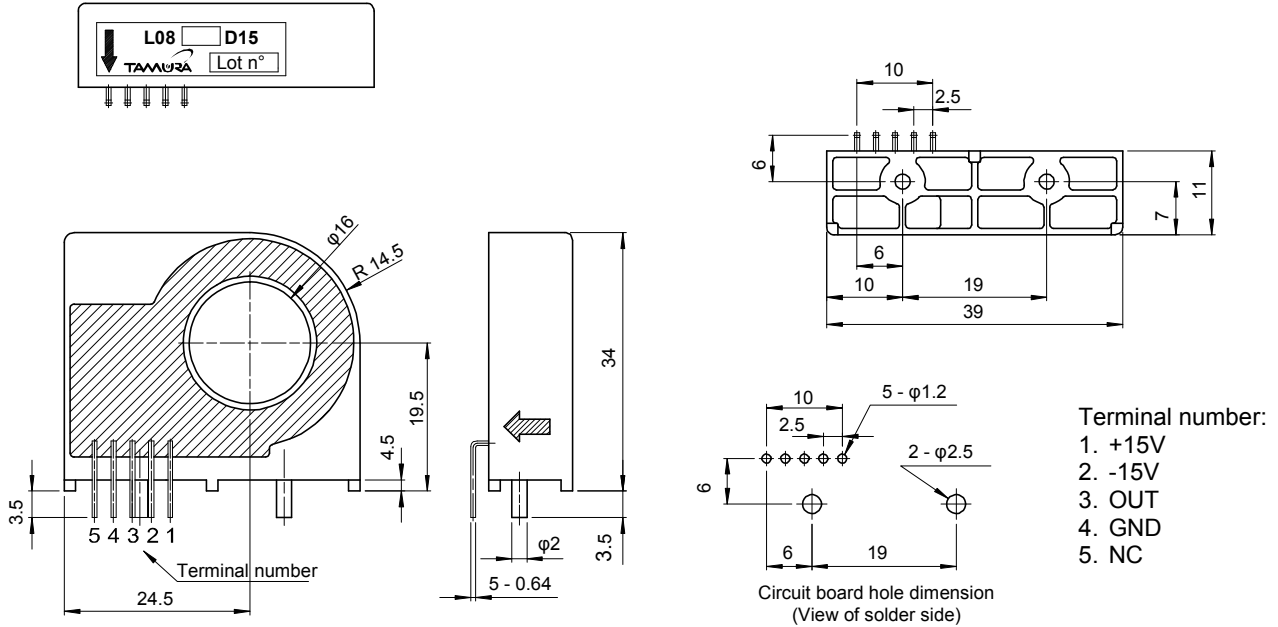

Electrical connection diagram

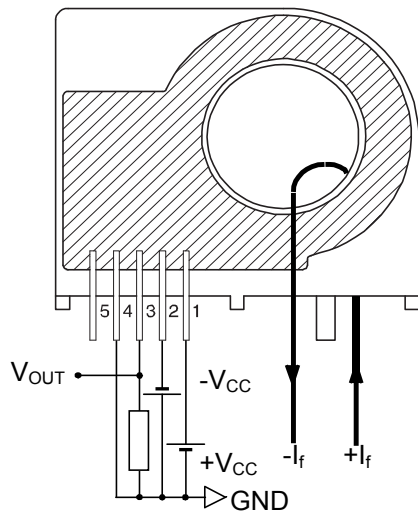

Package & Weight Information

Weight	Pcs/box	Pcs/carton	Pcs/pallet
20g	50	500	9000

