

Introduction

The AAT1151 evaluation board demonstrates performance, along with the suggested size and placement of external components, for the AAT1151 integrated buck regulator. The external components are selected for minimum size and optimum operation up to 700mA output current. The output voltage can be adjusted with the use of the 1.0V version of the AAT1151 and external resistors R3 and R4. Please refer to the AAT1151 product datasheet for more details about the AAT1151.

Layout

As with all switching power supplies, the board layout for the AAT1151 is critical (see Figure 1). Special care has been taken with the placement of the external components. The input capacitor (C1) placement is critical. It must be located immediately adjacent to the AAT1151. As shown in Figure 2, the LX node trace has been routed under C1 in order to facilitate a close placement of C1 next to the IC. The output voltage feedback trace has been routed on the portion of backside of the board which has a ground plane on the top side (see Figure 3). The trace is also routed to avoid the LX node and associated noise.

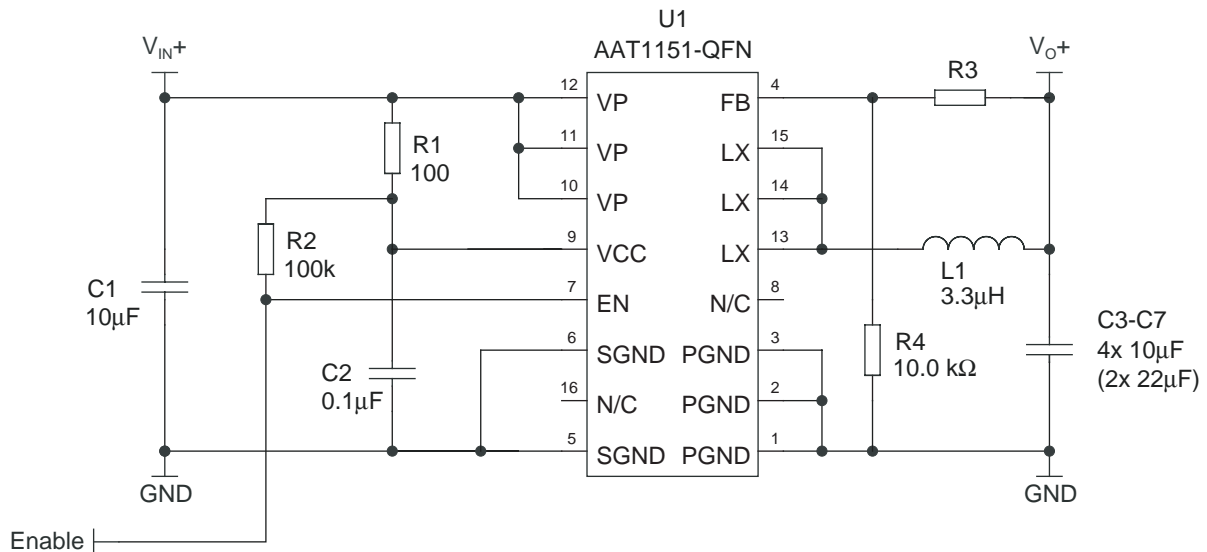

Figure 1: AAT1151 QFN Evaluation Board Schematic.

Specification	Test Conditions	Min	Typ	Max	Units
Input Voltage		2.7	3.6	5.5	V
Output Error Voltage		-3		+3	%
Output Current		0		700	mA

Table 1: AAT1151 QFN Evaluation Board Specifications.

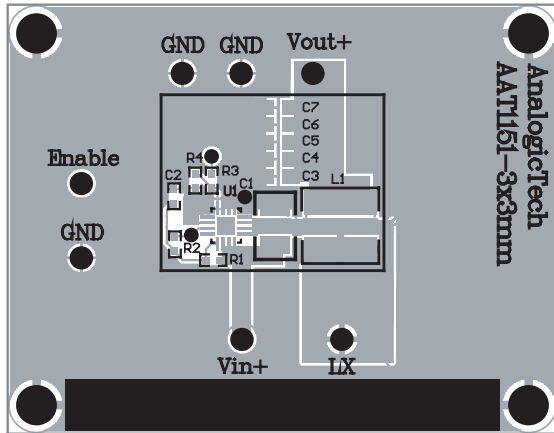

Figure 2: AAT1151 QFN Evaluation Board PCB Top Side.

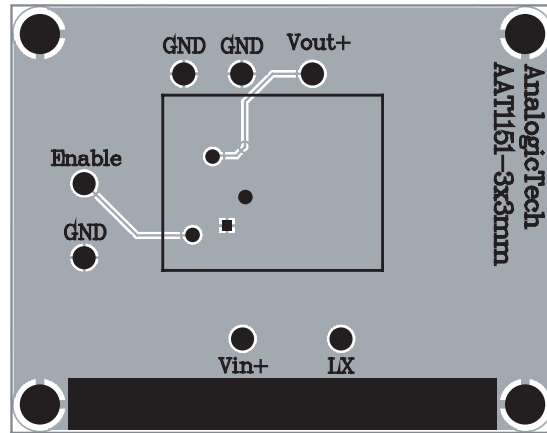

Figure 3: AAT1151 QFN Evaluation Board PCB Bottom Side.

Test Equipment

1. 6.0V, 1.0A laboratory power supply: HP33401A or equivalent.
2. DC 0A to 700 mA electronic load, capable of operation down to 1.0V: Keithley 2400 or equivalent. (When using the Keithley 2400, set the meter to operate in voltage source mode and set the load current by varying the current compliance [maximum current] of the meter.)
3. DC voltmeter: HP34401A or equivalent.
4. Oscilloscope: Tektronix TDS744A or equivalent.

Setup and Test

A. Load and Line Regulation (see connection diagram in Figure 4)

1. Apply a DC power supply and DC voltmeter across input voltage terminals V_{IN+} (positive terminal) and GND (negative terminal or return).
2. Apply a DC load and DC voltmeter to output terminals V_{O+} and GND.
3. Vary the load from 0A to 0.7A and the input voltage from 2.7V to 5.5V while monitoring the output voltage.
4. The output voltage as measured at the output terminals of the evaluation boards should not vary by more than $\pm 3\%$ of the nominal voltage.

B. Short-Circuit and Over-Temperature Protection

1. Raise the input voltage to 5.5V.
2. Apply a short from V_{O+} to GND at the evaluation board terminals.
3. Remove the short and verify that the output returns to its initial value.

C. Enable Input

1. Short the enable pin to GND. The output should decay to zero.
2. Remove the short applied to the enable pin. The output should recover to its initial value.

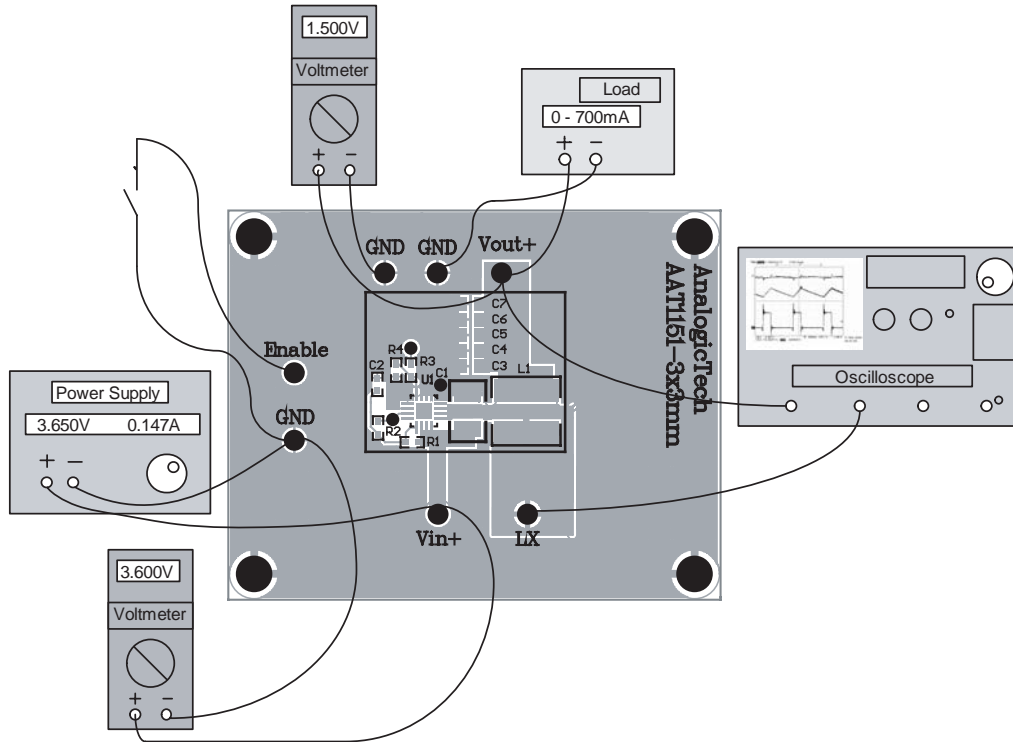

Figure 4: AAT1151 QFN Connection Diagram.

Component	Part Number	Description	Quantity	Manufacturer	
U1	AAT1151IVN-1.0-T1	1.0V 700mA Adjustable Buck Converter	1	AnalogicTech	
U1	AAT1151IVN-1.8-T1	1.8V 700mA Buck Converter	1	AnalogicTech	
U1	AAT1151IVN-2.5-T1	2.5V 700mA Buck Converter	1	AnalogicTech	
C3-C7 ¹	GRM21BR60J106KE19	10 μ F, 6.3V, X5R, 10%, 0805	4	MuRata	
C3-C7 ¹	GRM21BR60J226KE39	22 μ F, 6.3V, X5R, 10%, 0805	2	MuRata	
C1	GRM319R60J106KE01	10 μ F, 6.3V, X5R, 10%, 1206	1	MuRata	
C2	GRM155R61A104KA01	0.1 μ F, 25V, X5R, 10%, 0402	1	MuRata	
R1	Chip Resistor	100k Ω , 5%, 1/16W; 0402	1	Vishay	
R2	Chip Resistor	100k Ω , 5%, 1/16W; 0402	1	Vishay	
R3	Chip Resistor	AAT1151IVN-1.0-T1	See Table 3, 1%, 1/16W; 0402	1	Vishay
		AAT1151IVN-1.8-T1	0 Ω , 0402	1	
		AAT1151IVN-2.5-T1	0 Ω , 0402	1	
R4	Chip Resistor	10k Ω , 1%, 1/16W; 0402 (AAT1151IVN-1.0-T1 only)	1	Vishay	
L1	CDRH3D16-3R3	3.3 μ H 85m Ω 1.1A Shielded	1	Sumida	

Note 1: Either 4x 10 μ F or 2x 22 μ F capacitors can be used for C3-C7.

Table 2: AAT1151 QFN EVAL Bill of Materials.

Output Voltage

For an adjustable output, set R4 to 10k Ω and select R3 according to Table 3. For fixed output versions, R4 can be omitted and R3 is a short.

V_O (V)	R3 (kΩ)
1.0	0.00 (short)
1.1	1.00
1.2	2.00
1.25	2.55
1.3	3.01
1.4	4.02
1.5	4.99
1.6	6.04
1.7	6.98
1.8	8.06
1.85	8.45
1.9	9.09
2.0	10.0
2.1	11.0
2.2	12.1
2.3	13.0
2.4	14.0
2.5	15.0
3.3	23.2

Table 3: Resistor Selection for Adjustable Output Voltage for AAT1151IKS-1.0-T1 (R4 = 10k Ω).

AnalogicTech cannot assume responsibility for use of any circuitry other than circuitry entirely embodied in an AnalogicTech product. No circuit patent licenses, copyrights, mask work rights, or other intellectual property rights are implied.

AnalogicTech reserves the right to make changes to their products or specifications or to discontinue any product or service without notice, and advise customers to obtain the latest version of relevant information to verify, before placing orders, that information being relied on is current and complete. All products are sold subject to the terms and conditions of sale supplied at the time of order acknowledgement, including those pertaining to warranty, patent infringement, and limitation of liability.

AnalogicTech warrants performance of its semiconductor products to the specifications applicable at the time of sale in accordance with AnalogicTech's standard warranty. Testing and other quality control techniques are utilized to the extent AnalogicTech deems necessary to support this warranty. Specific testing of all parameters of each device is not necessarily performed.

Advanced Analogic Technologies, Inc.
830 E. Arques Avenue, Sunnyvale, CA 94085
Phone (408) 737-4600
Fax (408) 737-4611

