

**DUAL CHANNEL PWM CONTROL IC
WITH SCP/DTC FUNCTION****GENERAL DESCRIPTION**

The FP1451, a 1-chip composed of dual open collector transistor pulse-width-modulation control circuits with two error amplifiers and dead-time comparators (DTC), the FP1451 contains a 2.5V precision voltage reference regulator, under-voltage lockout circuit (UVLO), short circuit protection circuit (SCP), applied to offer space and low cost in many applications such as the DC/DC converter and backlight inverter.

Using few external components, FP1451, a high performance integrated IC, is designed for a control circuit. The circuit diagram of the typical application example is as below.

FEATURES

- Fixed Reference Voltage: 2.5V
- Reference Voltage Precision: 2% (FP1451)
- Output sink current up to 100mA
- Low quiescent supply current
- Wide operating voltage range: 3.6~40V
- Variable dead-time control (DTC)
- UVLO protection function
- SCP protection function
- Oscillator Frequency: Max. 500KHz
- Package: SOP16 / PDIP16

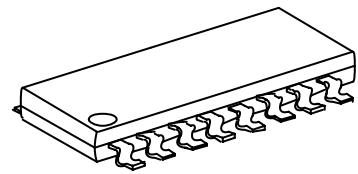
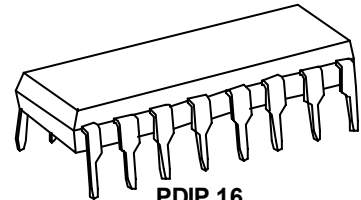
**SOP16****PDIP 16****TYPICAL APPLICATION**

- DC/DC converters for video cameras and TFT LCD monitor
- Back light CCFL inverter.

FUNCTIONAL BLOCK DIAGRAM

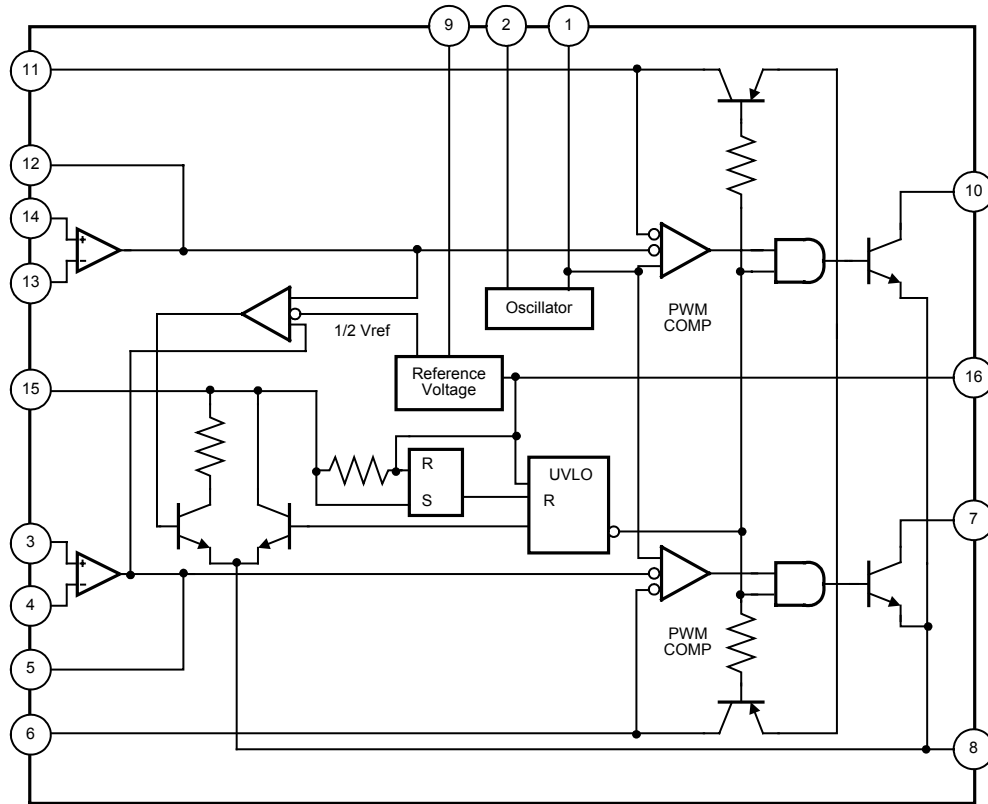

MARK VIEW

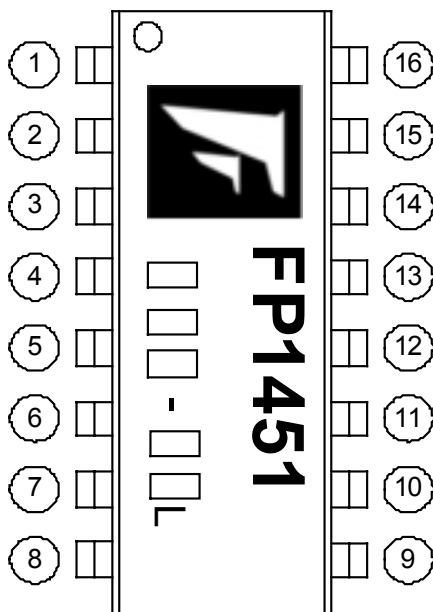

PIN DESCRIPTION

NAME	NO.	STATUS	DESCRIPTION
CT	1	I	Connect a Capacitor for Oscillator
RT	2	I	Connect a Resistor for Oscillator
EA1+	3	I	Error Amplifier 1 Non-inverting Input
EA1-	4	I	Error Amplifier 1 Inverting Input
FB1	5	O	Error Amplifier 1 Feedback Output
DTC1	6	I	Output 1 Dead-Time Comparator
OUT1	7	O	Open Collector Output 1
GND	8	P	IC Ground
VCC	9	P	IC Power Supply
OUT2	10	O	Open Collector Output 2
DTC2	11	I	Output 2 Dead-Time Comparator
FB2	12	O	Error Amplifier 2 Feedback Output
EA2-	13	I	Error Amplifier 2 Inverting Input
EA2+	14	I	Error Amplifier 2 Non-inverting Input
SCP	15	I	Short Circuit Protection Input
VREF	16	O	2.5V Reference Voltage Output

ORDER INFORMATION

Part Number	Operating Temperature	Package	Description
FP1451P-LF	-20°C 85°C	PDIP16	Tube
FP1451D-LF	-20°C 85°C	SOP16	Tube
FP1451DR-LF	-20°C 85°C	SOP16	Tape & Reel

IC DATE CODE DISTINGUISH

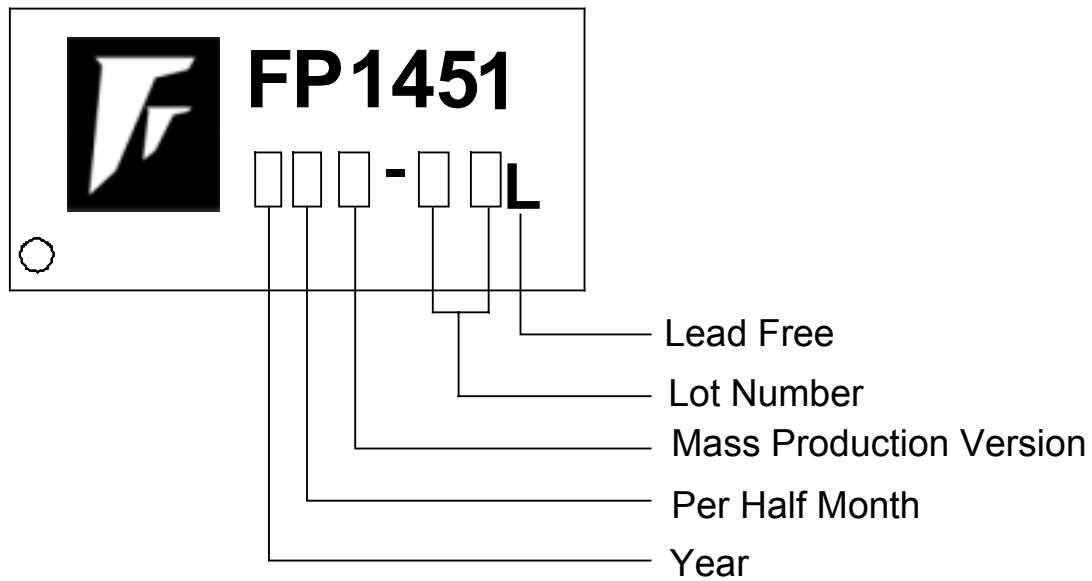

FOR EXAMPLE:

January A (Front Half Month), B (Last Half Month)

February C, D

March E, F -----And so on

Lot Number is the last two numbers

For Example:

A3311C62L

→ Lot Number

ABSOLUTE MAXIMUM RATINGS

Supply Voltage (V_{cc})	-----	+40V
Differential Input Voltage (V_{id})	-----	+20V
Collector Output Voltage (V_o)	-----	+40V
Collector Output Current (I_o)	-----	+150mA
Maximum Junction Temperature (T_j)	-----	150°C
Thermal Resistance Junction to Ambient (SOP package)	-----	175°C /W
Power Dissipation		
SOP16 package		
Ta=25	-----	650mW
Ta=70	-----	550mW
PDIP16 package		
Ta=25	-----	1000mW
Ta=70	-----	640mW
Operating Temperature Range	-----	-20°C 85°C
Storage Temperature Range	-----	-65°C 150°C
SOP16 Lead Temperature (soldering, 10 sec)	-----	+260
PDIP16 Lead Temperature (soldering, 20 sec)	-----	+260

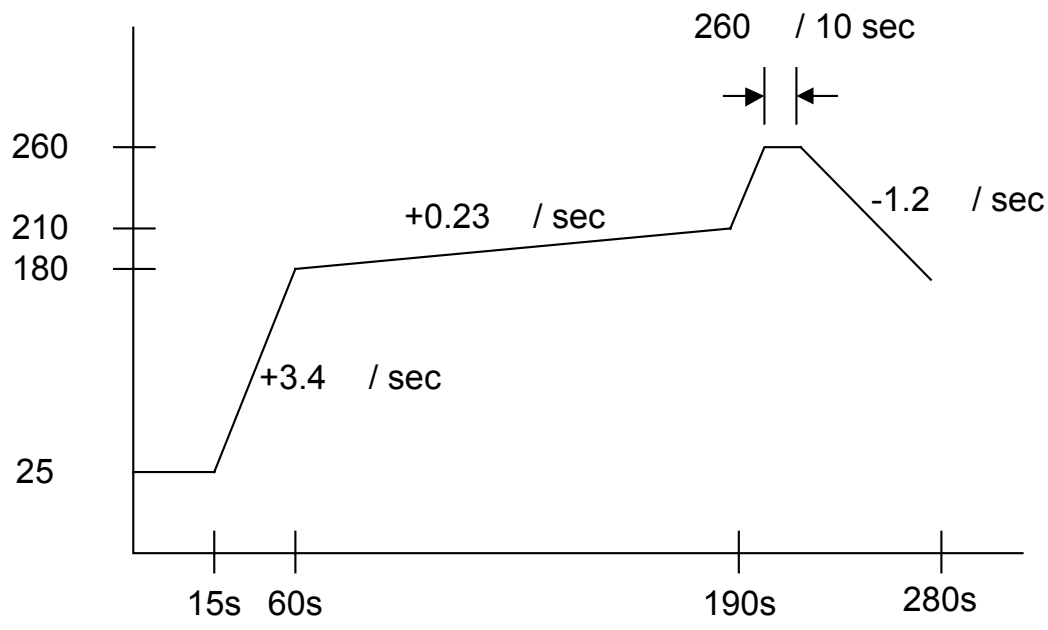

DC ELECTRICAL CHARACTERISTICS

Electrical characteristics over recommended operating free-air temperature range, $V_{CC}=6V$, $f=200kHz$ (unless otherwise noted)

Reference section

PARAMETER	SYMBOL	TEST CONDITIONS	MIN	TYP	MAX	UNIT
Output voltage (pin 16)	V_{REF}	$I_O=1mA$	2.45	2.5	2.55	V
Output voltage change with Temperature		$T_A=-20$ to 25		-0.1%	$\pm 1\%$	
		$T_A=25$ to 85		-0.2%	$\pm 1\%$	
Input voltage regulation	V_{REF}/V_{REF}	$V_{CC}=3.6V$ 40V		2	12.5	mV
Output voltage regulation	V_{REF}/V_{REF}	$I_O = 0.1mA$ to 1 mA		1	7.5	mV
Short-circuit output current	I_{SHORT}	$V_O=0$	3	10	30	mA

Undervoltage lockout section

PARAMETER	SYMBOL	TEST CONDITIONS	MIN	TYP	MAX	UNIT
Upper threshold voltage(V_{CC})	V_{UPPER}	$I_{O(REF)} = 0.1 mA$, $T_A=25$		2.72		V
Lower threshold voltage(V_{CC})	V_{LOW}			2.6		V
Hysteresis (V_{CC})	V_{HYS}		80	120		mV
Reset threshold voltage(V_{CC})	V_{RESET}		1.5	1.9		V

Short-circuit protection control section

PARAMETER	SYMBOL	TEST CONDITIONS	MIN	TYP	MAX	UNIT
Input threshold voltage (SCP)	V_{TH}	$T_A=25$	0.65	0.7	0.75	V
Standby voltage (SCP)	$V_{STANDBY}$	No pullup	140	185	230	mV
Latched input voltage (SCP)	V_{LATCH}	No pullup		60	120	mV
Input (source) current	I_{SOURCE}	$V_I=0.7V$, $T_A=25$	-10	-15	-20	μA
Comparator threshold voltage (FEEDBACK)	$V_{COMP(TH)}$			1.18		V

Oscillator section

PARAMETER	SYMBOL	TEST CONDITIONS	MIN	TYP	MAX	UNIT
Frequency	f	$C_T=330pF$, $R_T=10K$		200		KHz
Standard deviation of frequency	f	$C_T=330pF$, $R_T=10K$		10%		
Frequency change with voltage	f/ V	$V_{CC}=3.6V$ to 40V		1%		
Frequency change with Temperature	f/ T	$T_A=-20$ to 25		-0.4%	$\pm 2\%$	
		$T_A=25$ to 85		-0.2%	$\pm 2\%$	

Dead-time control section

PARAMETER	SYMBOL	TEST CONDITIONS	MIN	TYP	MAX	UNIT
Input bias current (DTC)	I_{BIAS}				1	μA
Latch mode (source) current(DTC)	I_{SOURCE}	$T_A=25$	-80	-200		μA
Latched input voltage (DTC)	V_{LATCH}	$I_O=40 \mu A$	2.3			V
Input threshold voltage at $f=10kHz$ (DTC)	V_{TH}	Zero duty cycle		2.05	2.25	V
		Maximum duty cycle	1.2	1.45		

DC ELECTRICAL CHARACTERISTICS (Cont.)

Error –amplifier section

PARAMETER	SYMBOL	TEST CONDITIONS	MIN	TYP	MAX	UNIT
Input offset voltage	V_{IO}	$V_O(\text{FEEDBACK})=1.25\text{V}$			± 6	mV
Input offset current	I_{IO}	$V_O(\text{FEEDBACK})=1.25\text{V}$			± 100	nA
Input bias current	I_{BIAS}	$V_O(\text{FEEDBACK})=1.25\text{V}$		160	500	nA
Common-mode input voltage range	V_{ICM}	$V_{CC}=3.6\text{V to }40\text{V}$	0.3		1.6	V
Open-loop voltage amplification	A_{VO}	$R_F=200\text{K}$	70	80		dB
Unity-gain bandwidth	BW			1.5		MHz
Common-mode rejection ratio	CMRR		60	80		dB
Positive output voltage swing	V_{POS}		$V_{ref}-0.2$			V
Negative output voltage swing	V_{NEG}				1	V
Output (sink) current (FEEDBACK)	I_{SINK}	$V_{ID}= -0.1\text{V}, V_O=1.25\text{V}$	1	4.0		mA
Output (source) current (FEEDBACK)	I_{SOURCE}	$V_{ID}=0.1\text{V}, V_O=1.25\text{V}$	-45	-90		μA

Output section

PARAMETER	SYMBOL	TEST CONDITIONS	MIN	TYP	MAX	UNIT
Collector off-state current	I_{OFF}	$V_O=40\text{V}$			10	μA
Output saturation voltage	V_{SAT}	$I_O=10\text{mA}$		0.7	1	V
Short-circuit output current	I_{SC}	$V_O=6\text{V}$		150		mA

Pwm comparator section

PARAMETER	SYMBOL	TEST CONDITIONS	MIN	TYP	MAX	UNIT
Input threshold voltage at $f=10\text{kHz}(\text{FEEDBACK})$	V_{TH}	Zero duty cycle		2.05	2.25	V
		Maximum duty cycle	1.2	1.45		

Total device

PARAMETER	SYMBOL	TEST CONDITIONS	MIN	TYP+	MAX	UNIT
Standby supply current	$I_{STANDBY}$	Off-state		1.3	1.8	mA
Average supply current	I_{AVE}	$R_T=10\text{K}$		1.7	2.4	mA

TYPICAL CHARACTERISTICS

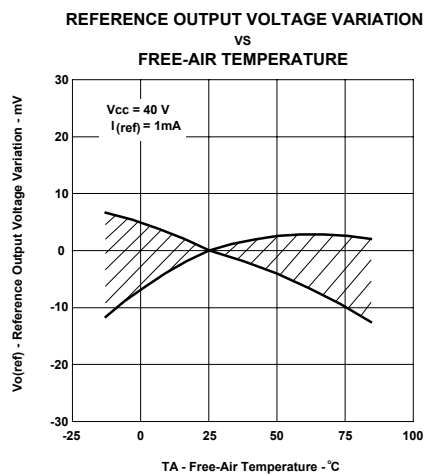
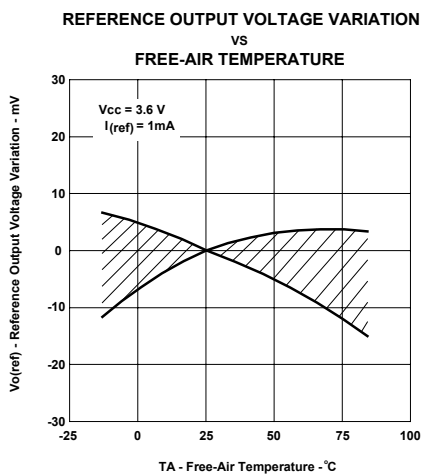
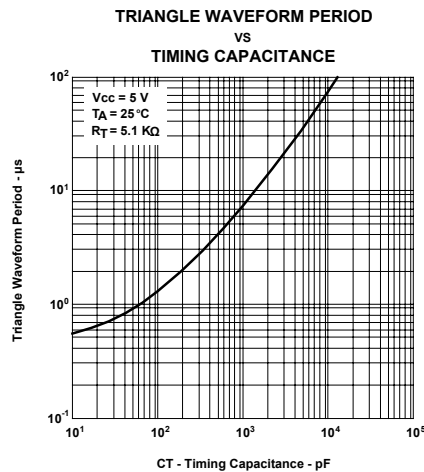
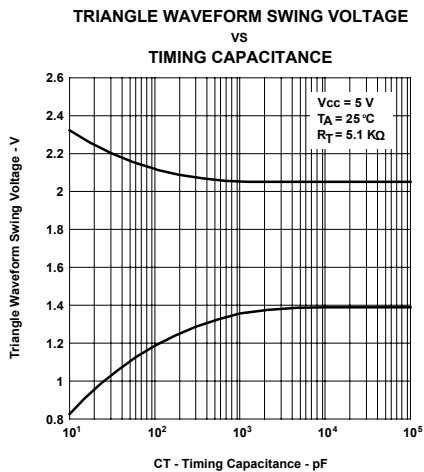
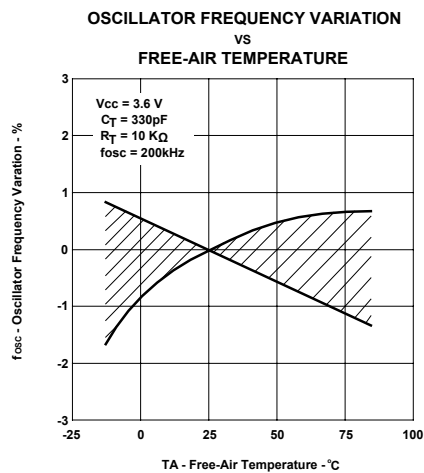
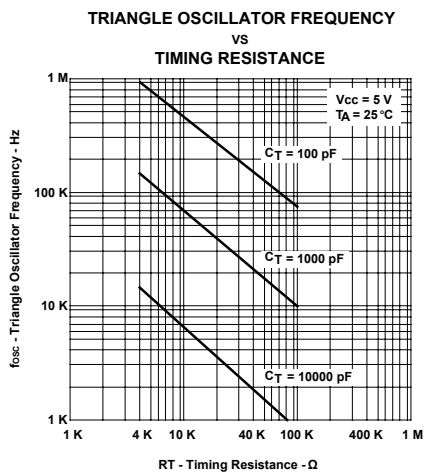

TYPICAL CHARACTERISTICS (Cont.)

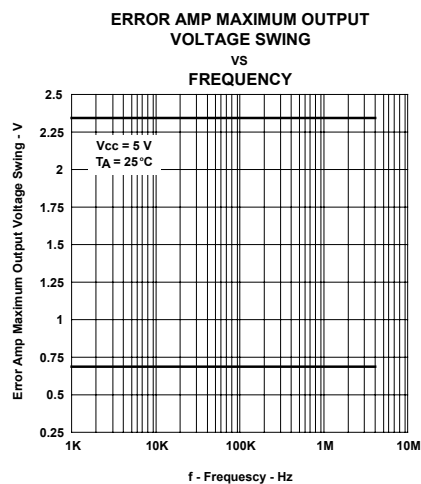
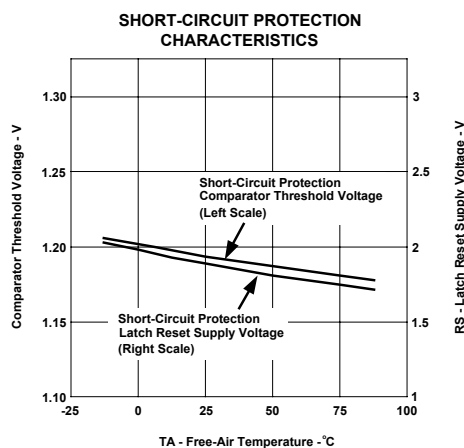
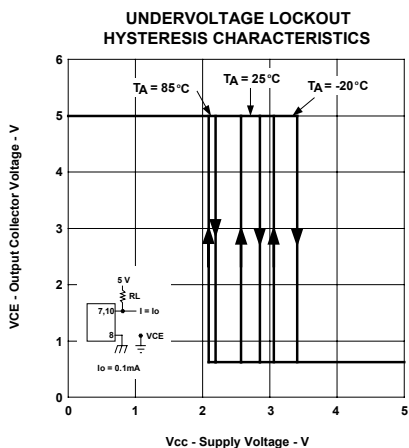
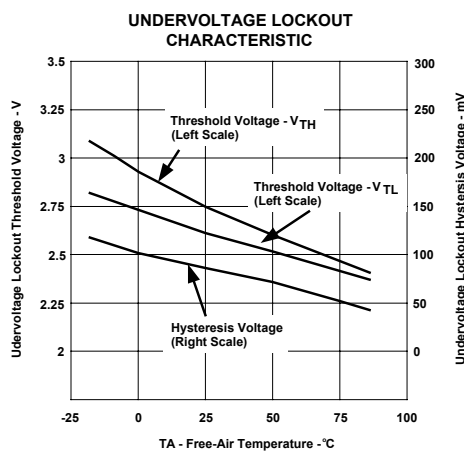
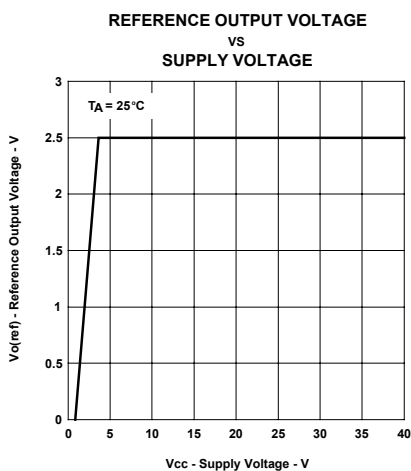

TYPICAL CHARACTERISTICS (Cont.)

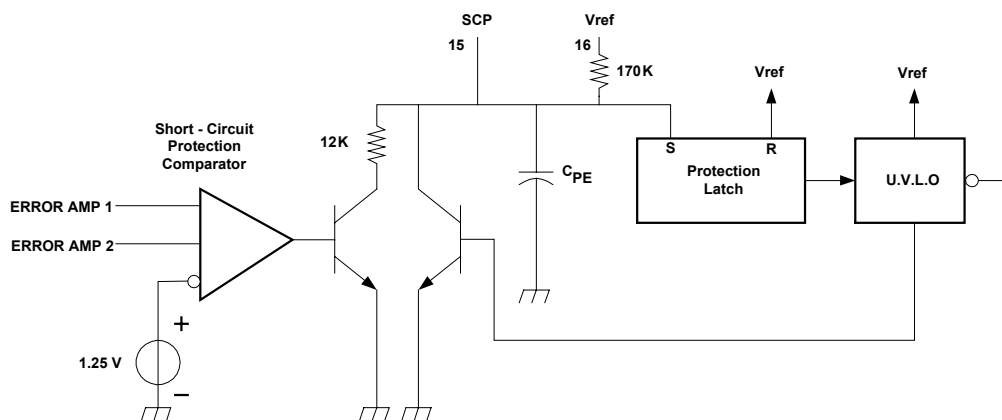
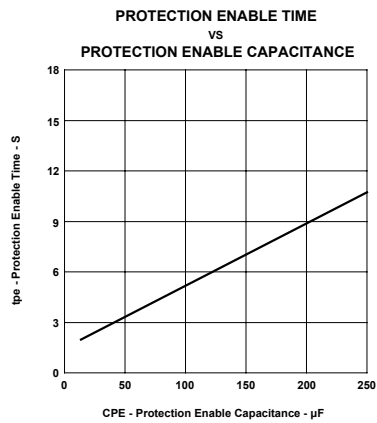

Figure 12

TYPICAL CHARACTERISTICS (Cont.)

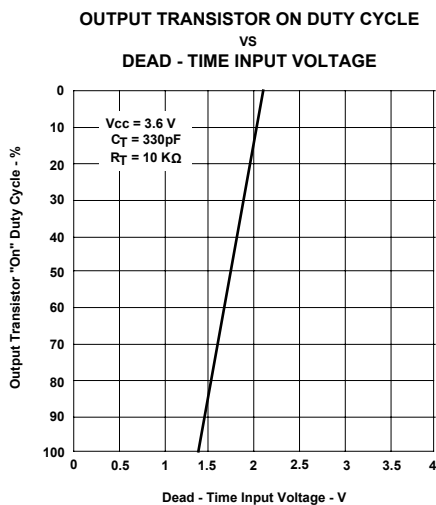

Figure 13

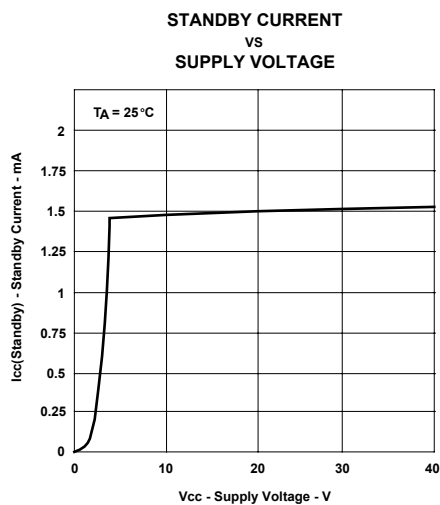

Figure 14

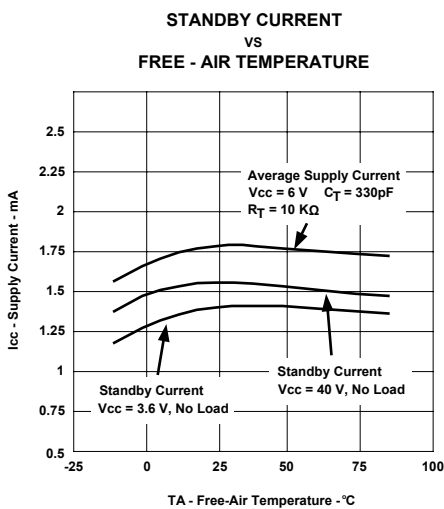

Figure 15

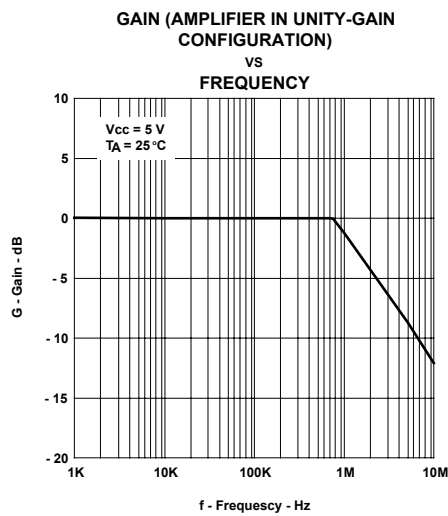
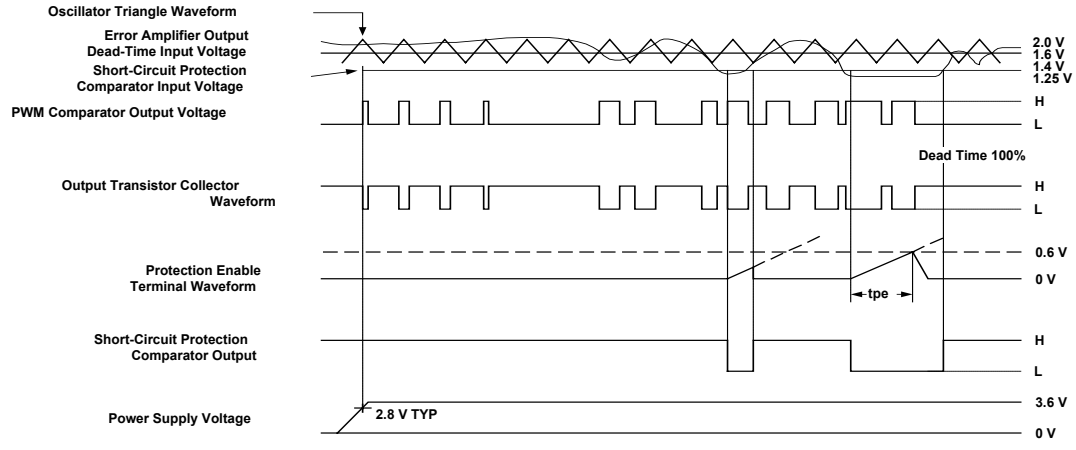

Figure 16

TIMING WAVEFORM



Protection Enable Time, $t_{pe} = (0.047 * 10E6 * C_{pe})$ in seconds

FP1451 Timing Diagram

APPLICATION NOTE

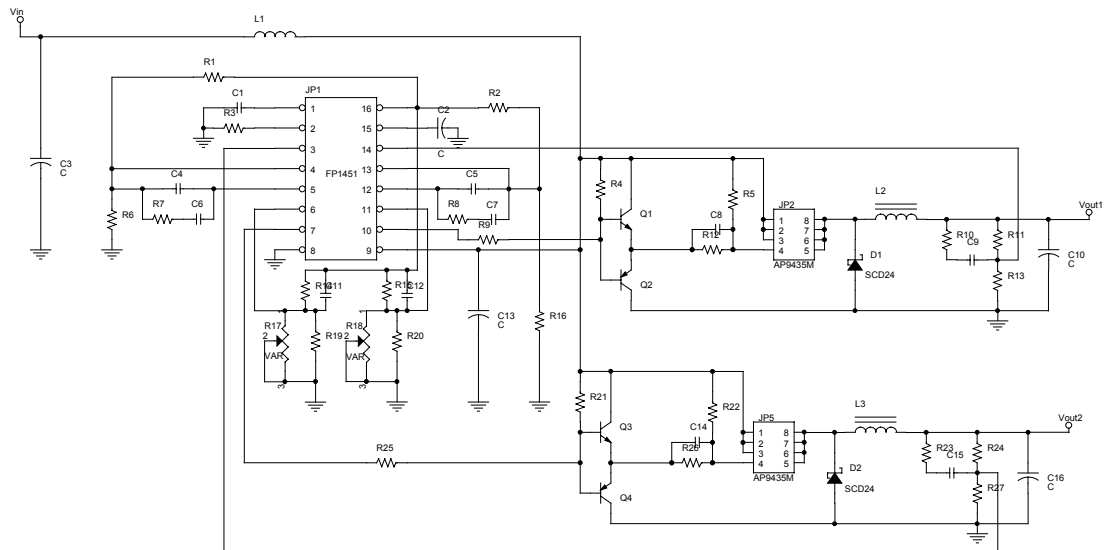
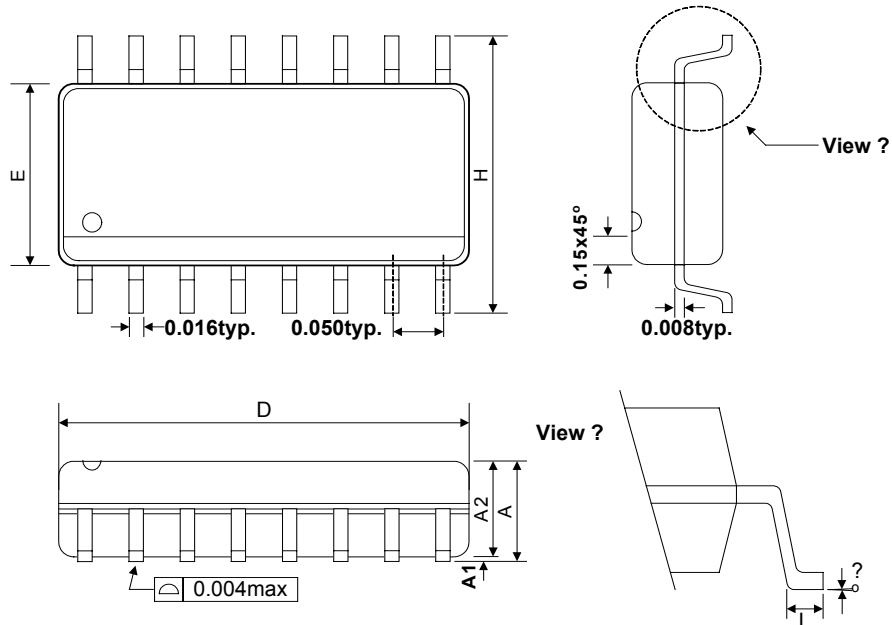

Figure 17. 2-channel dc-dc converter circuit

PACKAGE OUTLINE SOP16



SYMBOLS	MIN	MAX
A	0.053	0.069
A1	0.004	0.010
D	0.386	0.394
E	0.150	0.157
H	0.228	0.244
L	0.016	0.050
°	0	8

NOTE:

1. JEDEC OUTLINE: MS-012 AC
2. DIMENSIONS "D" DOES NOT INCLUDE MOLD FLASH, PROTRUSIONS OR GATE BURRS. MOLD FLASH, PROTRUSIONS AND GATE BURRS SHALL NOT EXCEED .15mm (.06in) PER SIDE
3. DIMENSIONS "E" DOES NOT INCLUDE INTER-LEAD FLASH, OR PROTRUSIONS.
4. INTER-LEAD FLASH AND PROTRUSIONS SHALL NOT EXCEED .25mm (.010in) PER SIDE.

PDIP16

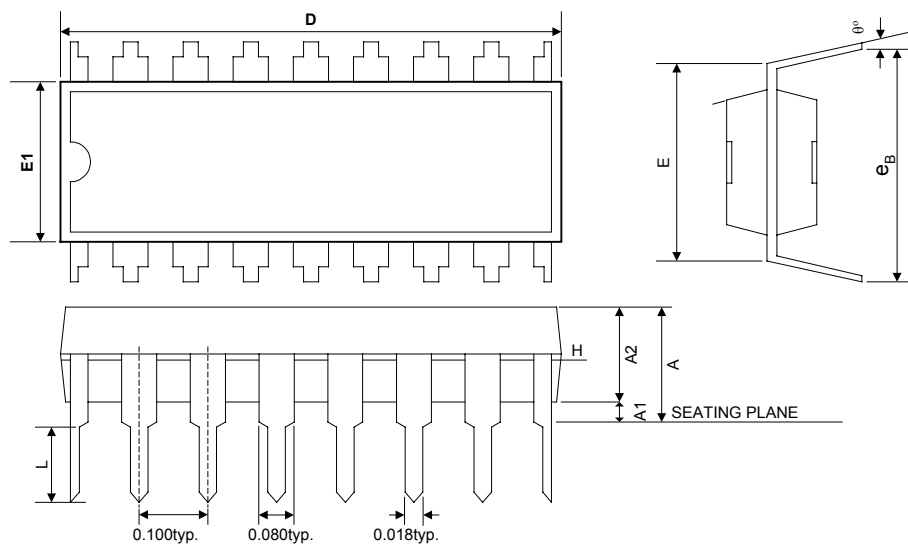

SYMBOLS	MIN.	NOR.	MAX.
A	—	—	0.210
A1	0.015	—	—
A2	0.125	0.130	0.135
D	0.735	0.755	0.775
E	0.300 BSC.		
E1	0.245	0.250	0.255
L	0.115	0.130	0.150
e_B	0.335	0.355	0.375
$^\circ$	0	7	15

NOTES:

1. JEDEC OUTLINE: MS-001 BB
2. "D", "E1" DIMENSIONS DO NOT INCLUDE MOLD FLASH OR PROTRUSIONS. MOLD FLASH OR PROTRUSIONS SHALL NOT EXCEED .010 INCH.
3. e_B IS MEASURED AT THE LEAD TIPS WITH THE LEADS UNCONSTRAINED.
4. POINTED OR ROUNDED LEAD TIPS ARE PREFERRED TO EASE INSERTION. DISTANCE BETWEEN LEADS INCLUDING DAM BAR PROTRUSIONS TO BE .005 INCH MINIMUM.
5. DATUM PLANE CONCORDANT WITH THE BOTTOM OF LEAD, WHERE LEAD EXITS BODY.

PACKING SPECIFICATIONS

BOX DIMENSION

TUBE INSIDE BOX AND CARTON

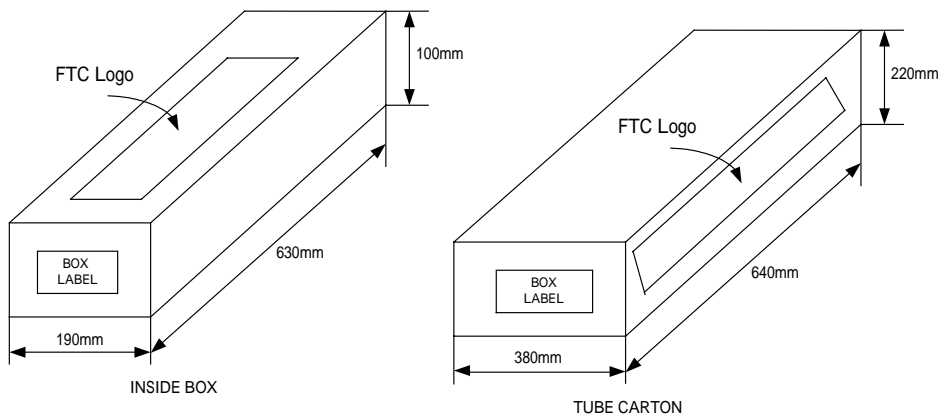

TAPE AND REEL INSIDE BOX AND CARTON

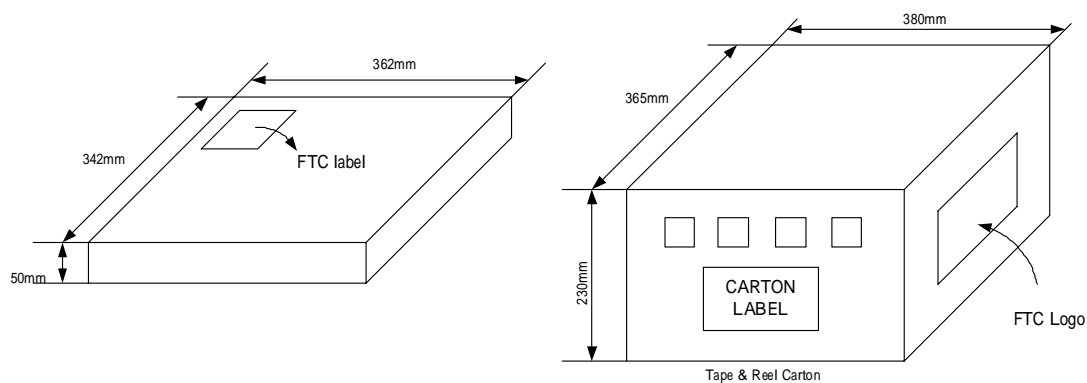

PACKING QUANTITY SPECIFICATIONS

50 EA/TUBE	2500 EA / REEL
50 TUBES / INSIDE BOX	4 INSIDE BOXES / CARTON
4 INSIDE BOXES / CARTON	

LABEL SPECIFICATIONS

TAPPING & REEL

Feeling Technology Corp. Product : FP1451 Lot No : A3311C62 D/C : 4Xx-XXL Q'ty :	<div style="border: 1px solid black; padding: 2px; display: inline-block;"> 無鉛 Lead Free </div>
--	--

CARTON

Feeling Technology Corp.	
Product Type: FP1451	
Lot No: A3311C62	
Date Code: 4Xx-XXL	
Package Type: SOP-16L	
Marking Type: Laser	無鉛 Lead Free
Total Q'ty: 10,000	

CARRIER TAPE DIMENSIONS

APPLICATION	W	P	E	F	D	D ₁
SOP16	16.0±0.3	8.0±0.1	1.75±0.1	7.5±0.1	1.55 ^{+0.1}	1.5 ^{+0.25}

APPLICATION	P ₀	P ₁	A ₀	B ₀	K ₀	t
SOP16	4.0±0.1	2.0±0.1	6.5±0.1	10.3±0.1	2.1±0.1	0.30±0.05

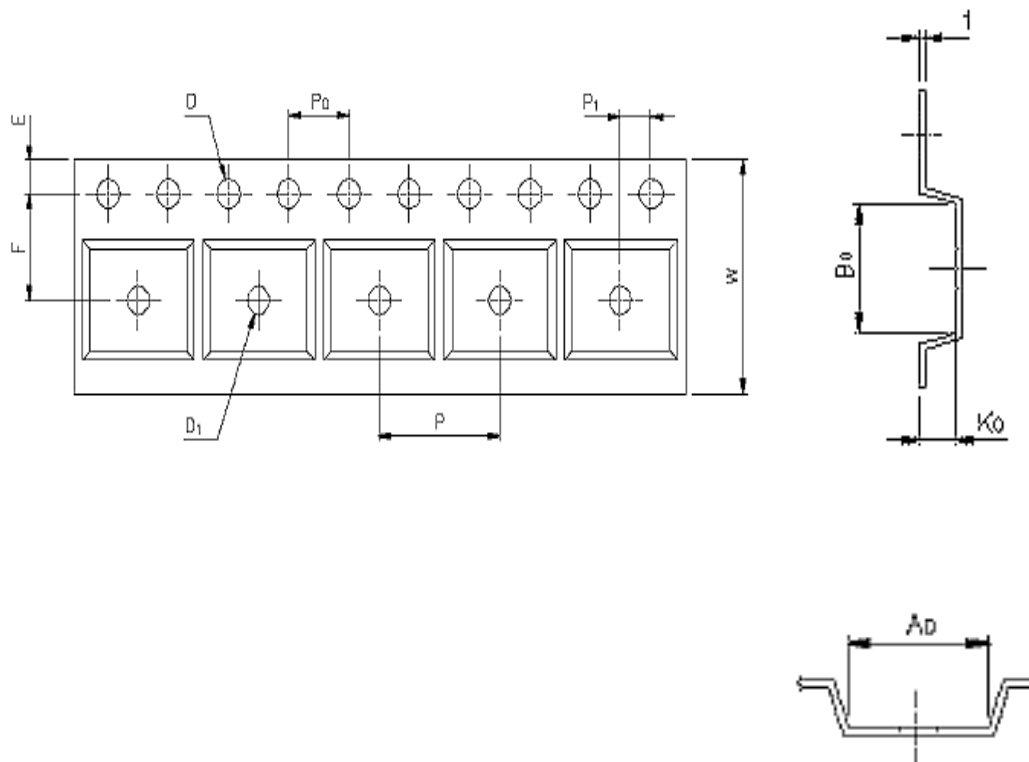

REEL DIMENSIONS

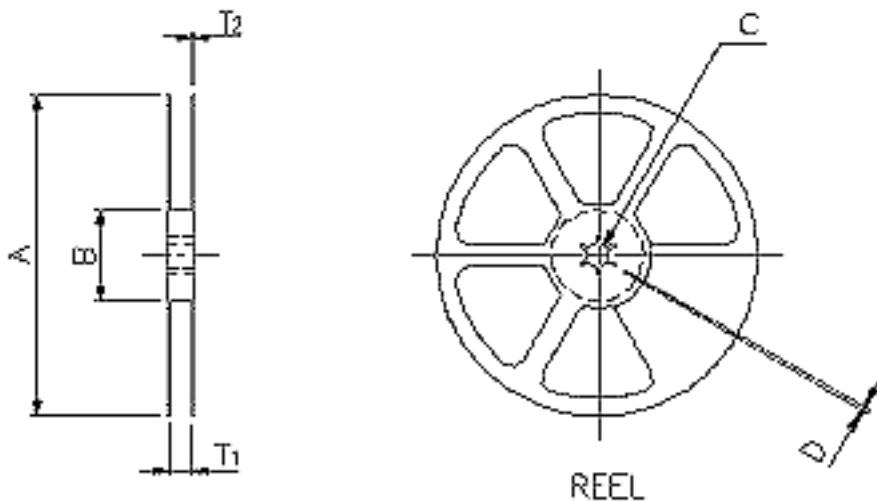

APPLICATION	MATERIAL	A	B	C	D	T ₁	T ₂
SOP16	PLASTIC REEL (BLUE)	330±3	100±2.0	13.0±0.5	2.0±0.5	16.4 ^{+0.3} _{-0.2}	2.5±0.5