

**Silicon NPN Power Transistors 2N5606 2N5608 2N5610 2N5612**

**DESCRIPTION**

- With TO-66 package
- Excellent safe operating area
- Low collector saturation voltage

**APPLICATIONS**

- For general-purpose amplifier ;  
and switching applications

**PINNING(see Fig.2)**

PIN	DESCRIPTION
1	Base
2	Emitter
3	Collector

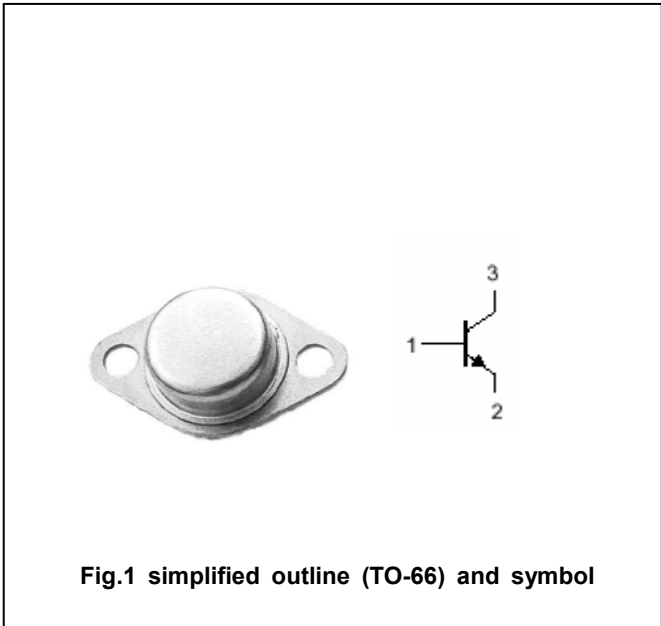

Fig.1 simplified outline (TO-66) and symbol

**Absolute maximum ratings(Ta=□)**

SYMBOL	PARAMETER	CONDITIONS	VALUE	UNIT
V <sub>CBO</sub>	Collector-base voltage	2N5606	80	V
		2N5608/5610	100	
		2N5612	120	
V <sub>CEO</sub>	Collector-emitter voltage	2N5606	60	V
		2N5608/5610	80	
		2N5612	100	
V <sub>EBO</sub>	Emitter-base voltage	Open collector	5	V
I <sub>C</sub>	Collector current		5	A
P <sub>D</sub>	Total power dissipation	T <sub>C</sub> =25□	25	W
T <sub>j</sub>	Junction temperature		150	□
T <sub>stg</sub>	Storage temperature		-65~150	□

**THERMAL CHARACTERISTICS**

SYMBOL	PARAMETER	VALUE	UNIT
R <sub>th j-c</sub>	Thermal resistance junction to case	4.37	□/W

---

**Silicon NPN Power Transistors 2N5606 2N5608 2N5610 2N5612**

---

**CHARACTERISTICS**T<sub>j</sub>=25 °C unless otherwise specified

SYMBOL	PARAMETER		CONDITIONS	MIN	TYP.	MAX	UNIT
V <sub>CEO(SUS)</sub>	Collector-emitter sustaining voltage	2N5606	I <sub>C</sub> =50mA ; I <sub>B</sub> =0	60			V
		2N5608/5610		80			
		2N5612		100			
V <sub>CEsat</sub>	Collector-emitter saturation voltage		I <sub>C</sub> =1A; I <sub>B</sub> =0.1A			0.5	V
V <sub>BE</sub>	Base-emitter on voltage		I <sub>C</sub> =2.5A ; V <sub>CE</sub> =5V			1.5	V
I <sub>CBO</sub>	Collector cut-off current		V <sub>CB</sub> =Rated V <sub>CBO</sub> ; I <sub>E</sub> =0			0.1	mA
I <sub>CEO</sub>	Collector cut-off current		V <sub>CE</sub> = Rated V <sub>CEO</sub> ; I <sub>B</sub> =0			1.0	mA
I <sub>EBO</sub>	Emitter cut-off current		V <sub>EB</sub> =5V; I <sub>C</sub> =0			0.1	mA
h <sub>FE</sub>	DC current gain	2N5606/5610	I <sub>C</sub> =2.5A ; V <sub>CE</sub> =5V	70		200	
		2N5608/5612		30		90	
f <sub>T</sub>	Transition frequency	2N5606/5610	I <sub>C</sub> =0.5A ; V <sub>CE</sub> =10V	70			MHz
		2N5608/5612		60			

Silicon NPN Power Transistors 2N5606 2N5608 2N5610 2N5612

PACKAGE OUTLINE

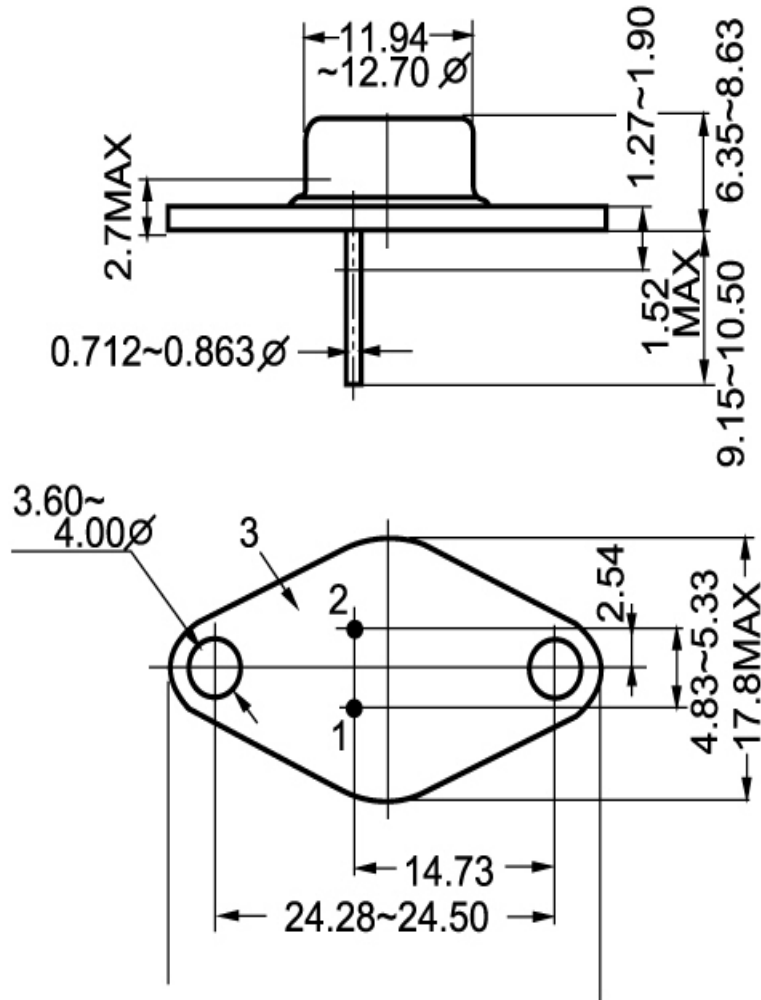

Fig.2 outline dimensions