

Operating and Service Manual

20T4G18

Model

1008254-501

Part Number

Serial Number

EC Declaration of Conformity

We; Amplifier Research
160 School House Road
Souderton, PA 18964

declare that our product;

the Model 200T4G18 amplifier

to which this declaration relates is in compliance with the requirements of the EEC EMC Directive (89/336/EEC) and Low Voltage Directive (73/23/EEC) in accordance with the relative standards listed below:

EMC:

EN 50082-1: 1992

Electromagnetic compatibility – Generic immunity standard

EN 50081-1: 1992

Electromagnetic emissions requirements for Industrial, Scientific, and Medical (ISM) Equipment

Safety:

EN 60950 (1995)

The CE marking is affixed on the device according to the EC Directives.



Donald R. Shepherd
President



INSTRUCTIONS FOR SAFE OPERATION

BEFORE APPLYING POWER

Review this manual and become familiar with all safety markings and instructions.

Verify that the equipment line voltage selection is compatible with the main power source.

Protection provided by the equipment may be impaired if used in a manner not specified by Amplifier Research.

INTENDED PURPOSES

This equipment is intended for general laboratory use in a wide variety of industrial and scientific applications. It is designed to be used in the process of generating, controlling, and measuring high levels of electromagnetic Radio Frequency (RF) energy. Therefore, the output of the amplifier must be connected to an appropriate load such as an antenna or field-generating device. It is the responsibility of the user to assure that the device is operated in a location which will control the radiated energy such that it will not cause injury and will not violate regulatory levels of electromagnetic interference.

HAZARDOUS RF VOLTAGES

The RF voltages on the center pin of the RF output connector can be hazardous. The RF output connector should be connected to a load before AC power is applied to the amplifier. Do not come into contact with the center pin of the RF output connector or accessories connected to it. Place the equipment in a non-operating condition before disconnecting or connecting the load to the RF output connector.

SAFETY GROUND

This equipment is provided with a protective earth terminal. The main power source to the equipment must supply an uninterrupted safety ground of sufficient size to the input wiring terminals, power cord, or supplied power cord set. The equipment **MUST NOT BE USED** if this protection is impaired.

PHYSICAL DAMAGE

The RF amplifier should not be operated if there is physical damage, missing hardware, or missing panels.

MAINTENANCE CAUTION

Adjustment, maintenance, or repair of the equipment must be performed only by qualified personnel. Hazardous energy may be present while protective covers are removed from the equipment even if disconnected from the power source. Contact may result in personal injury. Replacement fuses are required to be of specific type and current rating.

SAFETY SYMBOLS



This symbol is marked on the equipment when it is necessary for the user to refer to the manual for important safety information.



Dangerous voltages are present. Use extreme care.

CAUTION: The caution symbol denotes a potential hazard. Attention must be given to the statement to prevent damage, destruction, or harm.



Indicates protective earth terminal.

RANGE OF ENVIRONMENTAL CONDITIONS

This equipment is designed to be safe under the following environmental conditions:

- Indoor use
- Altitude up to 2000M
- Temperature of 5°C to 40°C
- Maximum relative humidity 80% for temperatures up to 31°C. Decreasing linearly to 50% at 40°C.
- Main supply voltage fluctuations not to exceed $\pm 10\%$ of the nominal voltage or minimum and maximum autoranging values.
- Pollution degree 2: Normally non-conductive with occasional condensation. While the equipment will not cause hazardous condition over this environmental range, its performance may vary.

COOLING AIR

Care should be exercised not to block the cooling air inlets or outlets. Cooling air blockage can result in damage to the RF amplifier or intermittent shut-downs.

ADDITIONAL WARNINGS & NOTES



WARNING:

This equipment operates at potentially lethal voltages. Only trained, qualified personnel should operate, maintain, or service it.

Hazardous energy may be present while protective covers are removed from the equipment even if disconnected from the power source. Contact may result in personal injury.



CAUTION:

Adjustment, maintenance, or repair of the equipment must be performed only by qualified personnel.



CAUTION:

Replacement fuses are required to be of specific type and current rating.



CAUTION:

The information in this document was obtained from reliable sources and was believed to be accurate at the time of publication. Since subsequent modifications to the machine may have been made, use this information only as a guide. Carefully compare the unit's actual configuration and operation to the descriptions in this manual before you undertake to operate, service, or modify this machine. Any variance or modification should be noted, dated, and initialed in the discrepant part of all manuals on hand for future reference. If you have technical or editorial comments you wish to make to the manufacturer, please write them on photocopies of the relevant sheets.

NOTE: The contents of this document are the property of the manufacturer and this document is delivered on the express condition that it not be disclosed, reproduced in whole or in part, or used for manufacture for anyone other than the manufacturer without its written consent, and that no right is granted to disclose or so use any information in this document.

TABLE OF CONTENTS

TABLE OF CONTENTS	i
1. DESCRIPTION AND SPECIFICATIONS.....	1
1.1 TWTA Description.....	1
1.2 Suggested Applications.....	1
1.3 Specifications.....	1
1.4 Accessories.....	1
1.5 Test Data Sheet	2
2. THEORY OF OPERATION.....	5
2.1 Design of the amplifier.....	5
2.2 Description of the RF Circuit.....	5
2.3 Description of the Power Supply	6
3. OPERATION.....	7
3.1 Warnings and Cautions	7
3.2 Installation.....	8
3.2.1 Unpacking	8
3.2.2 Mounting.....	8
3.2.3 Cooling Requirements.....	9
3.2.4 AC Line Power Connections.....	10
3.2.5 RF Output Connections.....	10
3.2.6 External Interlock Connector	10
3.3 Front Panel Features.....	11
3.4 Front Panel Display and Soft Keys	12
3.5 Rear Panel Features.....	16
3.6 Initial Turn On and Warm-up Procedure	16
3.7 Emergency Bypass Operation	17
3.8 Remote IEEE-488 Operation	18
3.9 TWTA General Considerations.....	23
4. MAINTENANCE	25
4.1 Safety Warning	25
4.2 Unauthorized Repairs.....	25
4.3 Preventive Maintenance.....	25
4.4 Troubleshooting	26
4.5 Non-Repairable Modules	27
5. TECHNICAL DOCUMENTATION.....	29
5.1 Top Level Build Tree	30
5.2 Schematics.....	31
5.3 Wiring Diagrams.....	33
5.4 Parts Lists.....	35
5.4.1 Parts List, HPA Logic and Control Module, A16485-000.....	36
5.4.2 Parts List, Power Supply (Short) For TWT 5172, A23720-099	38
5.4.3 Parts List, Emergency Bypass Board, A24830-001	39
5.4.4 Parts List, Emergency Bypass Board, A24830-002	40
5.4.5 Parts List, HPA Interface Board (Plastic), A25444-000	41

5.4.6	Parts List, HPA 20W 4.2-18GHZ (AR), A28825-300.....	44
5.4.7	Parts List, Microwave Power Assembly, AR, A28826-000.....	45
5.5	Recommended Spare Parts.....	46
5.6	Sample Program for IEEE-488 Communication.....	47

ILLUSTRATIONS

Figure 3-1	- Rear View of HPA	9
Figure 3-2	- TWTA Front Panel Features	11
Figure 3-3	- Front Panel Display Screens.....	12
Figure 3-4	- TWTA Rear Panel Features.....	15

TABLES

Table 1	- Front Panel Features.....	9
Table 2	- Rear Panel Features.....	15
Table 3	- Catalog of IEEE-488 Commands.....	17
Table 4	- Catalog of Status Codes	18
Table 5	- Catalog of Fault Codes.....	19
Table 6	- Catalog of System State Codes	19
Table 7	- Catalog of *STA?; Response Codes	20
Table 8	- Catalog of *STB?; Response Codes	20

1. DESCRIPTION AND SPECIFICATIONS

This manual provides operating, interfacing and selected service information pertinent to Amplifier Research Model 20T4G18 Broadband Microwave Amplifier. The Model 20T4G18 is a 20 watt C/I/J band traveling-wave tube amplifier (TWTA).

1.1 TWTA DESCRIPTION

The amplifier uses a broadband micro- traveling-wavetube (TWT) to provide 20 watts minimum output over the TWT amplifier's full bandwidth. The amplifier is well suited for susceptibility and general laboratory testing where instantaneous bandwidth and high gain are required.

The amplifier is completely self-contained and packaged for standard 19-inch rack mounting or bench top use. The front panel of the rack mountable amplifier is 5.25 inches high, and the overall unit is 25.25 inches deep, excluding the rear-panel connectors. For bench top use, the amplifier is supplied in an enclosure with integral carrying handles.

Primary power is 99-260 volts 50-60 Hz., single phase. An efficient switching power supply design provides minimum power consumption. A fast regulation control loop and a high degree of filtering ensure performance within specifications over a wide range of operating conditions. The amplifier is fully enclosed, and the upper and lower panels of the rack mountable amplifier are interlocked to reduce the likelihood of accidental contact with high voltage.

1.2 SUGGESTED APPLICATIONS

- RF Susceptibility testing
- Antenna and component testing
- Equipment calibration
- General laboratory instrumentation

1.3 SPECIFICATIONS

Refer to the Amplifier Research Data Sheet on the following pages for detailed specifications.

1.4 ACCESSORIES

Amplifier Research offers a number of accessories for use with this amplifier including:

- Directional coupler
- Antenna
- Flexible transmission line

Refer to a current Amplifier Research catalogue for Microwave Accessories.

1.5 TEST DATA SHEET

A Test Data Sheet for a specific unit is prepared at the time of manufacture and is included with the unit's copy of this manual.



160 School House Road, Souderton, PA 18964-9990 USA
Phone 215-723-8181•FAX 215-723-5688

MODEL 20T4G18
M1, M2
20 WATTS CW
4.2 - 18 GHz

The Model 20T4G18 is a self contained, forced air cooled, broadband traveling wave tube (TWT) microwave amplifier designed for applications where wide instantaneous bandwidth, high gain and moderate power output are required. A reliable micro TWT provides a conservative 20 watts minimum at the amplifier output connector. Stated power specifications are at fundamental frequency.

The amplifier's front panel digital display shows forward and reflected output plus extensive system status information accessed through a series of menus via soft keys. Status indicators include power on, warm-up, standby, operate, faults, excess reflected power warning and remote. Standard features include a built-in IEEE-488 (GPIB) interface, 0dBm input, VSWR protection, gain control, RF output sample port, auto sleep, plus monitoring of TWT helix current, cathode voltage, collector voltage, heater current, heater voltage, baseplate temperature and cabinet temperature. Modular design of the power supply and RF components allow for easy access and repair. Use of a switching mode power supply results in significant weight reduction.

Housed in a stylish contemporary cabinet this unit is designed for benchtop use but can be removed from the cabinet for rack mounting. The Model 20T4G18 provides readily available RF power for a variety of applications in Test and Measurement, (including EMC RF susceptibility testing), Industrial and University Research and Development, and Service applications.

20T4G18 TYPICAL POWER OUTPUT

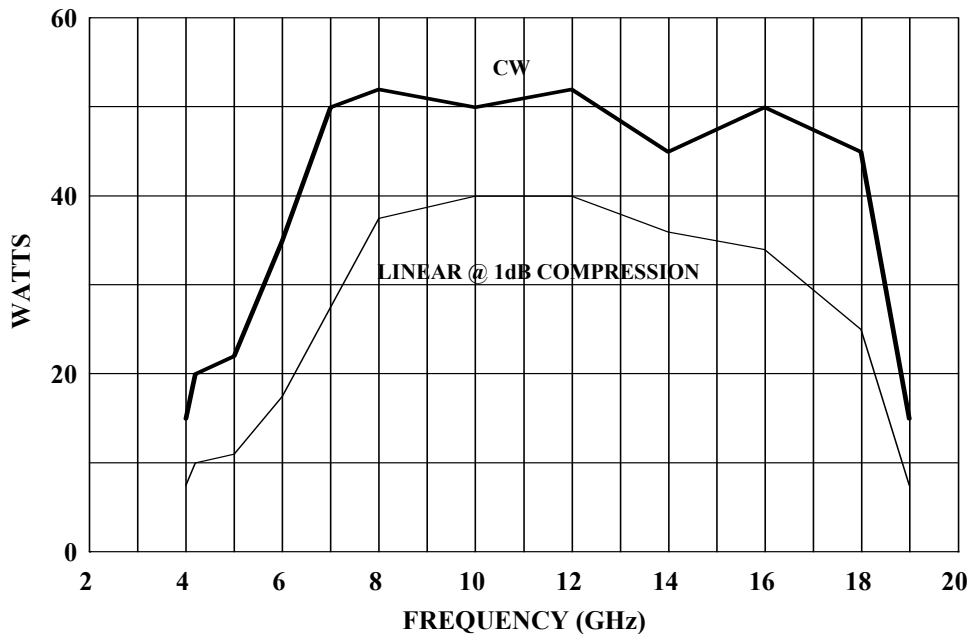

REV111804

SPECIFICATIONS

Model 20T4G18

POWER (fundamental), CW, @ OUTPUT CONNECTOR

Nominal..... 42 watts
 Minimum 20 watts
 Linear @ 1dB Compression 10 watts minimum

FLATNESS ±9 dB maximum, 4.2 - 18 GHz
 ±5dB maximum, 8.0 - 18 GHz

FREQUENCY RESPONSE..... 4.2 - 18 GHz instantaneously

INPUT FOR RATED OUTPUT 1.0 milliwatt maximum

GAIN (at maximum setting) 43 dB minimum

GAIN ADJUSTMENT (continuous range)..... 35 dB minimum

INPUT IMPEDANCE..... 50 ohms, VSWR 2.0:1 maximum

OUTPUT IMPEDANCE..... 50 ohms, VSWR 2.5:1 typical

MISMATCH TOLERANCE Output power foldback protection at reflected power exceeding 20 watts. Will operate without damage or oscillation with any magnitude and phase of source and load impedance. May oscillate with unshielded open due to coupling to input. Should not be tested with connector off.

MODULATION CAPABILITY Will faithfully reproduce AM, FM, or pulse modulation appearing on the input signal. AM peak envelope power limited to specified power.

NOISE POWER DENSITY Minus 80 dBm/Hz (maximum)
 Minus 90 dBm/Hz (typical)

HARMONIC DISTORTION (at 20 watts) 4.2-4.5GHz; Minus 0dBc maximum,
 Minus 1dBc typical
 4.5-5GHz; Minus 1dBc maximum,
 Minus 2dBc typical
 5-7GHz; Minus 2.5dBc maximum,
 Minus 4dBc typical
 7- 10 GHz; Minus 5dBc maximum,
 Minus 9dBc typical
 10 - 12 GHz; Minus 8dBc maximum,
 Minus 12dBc typical
 Above 12 GHz; Minus 20dBc maximum,
 Minus 30dBc typical

PRIMARY POWER 99-260 VAC
 50/60 Hz single phase,
 600 VA maximum

CONNECTORS

RF input..... Type N female on rear panel
 RF output..... Type TNC female on rear panel
 RF output sample port..... Type N female on rear panel
 GPIB..... IEEE-488-(f)
 Interlock DB-15 female on rear panel

COOLING Forced air (self contained fans), air entry and exit in rear.

MODEL CONFIGURATION

MODEL NUMBER	DESCRIPTION	WEIGHT	SIZE (H x W x D)
20T4G18	With removable enclosure	32 kg (70lb)	50.3 x 16.5 x 68.6 cm 19.8 x 6.5 x 27 in
20T4G18M1	Enclosure removed for rack mounting, slides and front handles installed	25 kg (55lb)	48.3 x 13.3 x 68.6 cm 19.0 x 5.25 x 27 in
20T4G18M2	Shipped without an outer cabinet	23 kg (50lb)	48.3 x 13.3 x 68.6 cm 19.0 x 5.25 x 27 in

2. THEORY OF OPERATION

2.1 DESIGN OF THE AMPLIFIER

The model 20T4G18 TWT amplifier consists of four principal subsystems. Two of these subsystems, the microwave power assembly (A28826-000) and the TWT power supply (A23720-099) are discussed in sections 2.2 and 2.3, respectively.

The other two subsystems are the microprocessor control system and the TWTA packaging. These both consist of a number of subassemblies. See the build tree in section 5.1 for further information about how the parts lists are structured.

The heart of the microprocessor control system is the control head assembly (A25403-302), which consists of the CPU board (A25450-000), the HPA display board (A25425-001), and the data link board (A22488). The microprocessor control system supervises the power supply, provides metering display, processes operator front panel inputs, and enables communication with a host computer over the IEEE-488 interface.

The control head is provided with its own power supply and, other than thru the IEEE-488 interface bus, is electrically isolated from the amplifier. Communication with the amplifier is via fiberoptic links to the HPA interface assembly (A25444-000).

The TWTA packaging consists of cabinet assembly (A28827-000). The cooling system utilizes a DC blower with a dedicated DC power supply.

2.2 DESCRIPTION OF THE RF CIRCUIT

The TWTA consists of two stages of RF amplification: a solid state preamp assembly with adjustable gain (E01122-000) and a traveling-wave tube amplifier (E08137-000).

The type N RF input connector is located on the rear panel. The RF input is fed to the input connector on the solid state preamp. The solid state preamp's output drives the RF input of the TWT. The RF output of the TWT is a type TNC coaxial connector. The output is directed through a short cable to a -35/-35 dB dual directional coupler. The output TNC connector of the coupler protrudes through the rear panel of the TWTA to function as the RF output connector.

The reverse port on the directional coupler is connected to a crystal detector, whose output is used for VSWR protection by the power supply logic board, for VSWR measurement in the leveling loop, and for reverse power measurement on the HPA interface board.

The forward port output is split by a -10 dB coupler. The direct output is connected to a crystal detector via a pad. The output of the crystal detector is used on the HPA interface board to measure forward power. The side port of the coupler is connected to the RF sample port on the rear panel. With an optional reverse power sample port on the rear panel, an additional -10 dB coupler is connected to the reverse port of the system's dual directional coupler. The output port of the -10 dB coupler is connected to a detector diode whose output is used on the HPA interface board to measure reflected power and for VSWR foldback and protection. The coupled port of the -10 dB coupler is connected to the reverse power sample port on the rear panel.

Amplifier gain is determined by the solid state preamp (SSA), which has a voltage-controlled attenuator. The control head determines the output of a digital-to-analog converter (DAC) on the HPA interface board. The output of the DAC controls the SSA attenuator. The emergency bypass board (A24830) mounted behind the front panel is provided with a circuit that increases the attenuation so that forward power is limited to a level on the order of 50 watts. Forward power is also limited so that reverse power does not exceed approximately 20 watts. In emergency bypass operation (see section 3.7) the gain control signal is provided locally by means of a potentiometer on the emergency bypass board. The foldback circuit remains on line in emergency bypass operation.

2.3 DESCRIPTION OF THE POWER SUPPLY

The TWT power supply is of modular construction. Low voltage power for logic and control of the entire power supply assembly is provided by the low voltage power supply module (A23687-001). In addition this module provides DC power for the HPA interface and emergency bypass boards. Control logic and TWT protection circuits are contained in the HPA logic and Control Assembly (A16485-000).

The Heater Power Supply Module (A10010-000) powers the TWT DC heater. The Micro- TWT requires no separate grid or anode supply.

The high voltage power supply consists of the following: the Power Factor Correction module (A23683-100) converts line voltage to DC for the high voltage switching supply. Switching transistors are on the Power Board Assembly (A23710-000), and switching is controlled by the Pulse Width Modulation (PWM) Board (A10017-100). The high voltage transformer and rectifiers are contained in the High Voltage Diode/Cap Assembly (A21457-001). The high voltage DC is filtered in the HV Filter Assembly (A21454).

Low voltage interconnects between the power supply modules are through a motherboard. It is installed in a finned heat sink assembly to which the modules are bolted. The heat sink is cooled by the incoming cabinet air. The Heat Sink/Motherboard assembly is A23711-000.

3. OPERATION

3.1 WARNINGS AND CAUTIONS

Throughout this manual, the symbol:



WARNING:

indicates that a hazard exists that may result in personal injury or loss of life.



CAUTION:

indicates that failure to follow procedures may result in damage to the equipment.



WARNING: DANGER - High Voltage Present:

Electrical equipment in this TWTA generates and stores high-voltage energy that can result in fatal electrocution. Do not operate the TWTA with covers or the front panel removed.

Service work must be performed only by technicians thoroughly familiar with the high-voltages present in microwave tube amplifiers in general, and with this equipment in particular.

Never handle the TWT leads or the high-voltage connectors unless the unit has been unplugged and it has been positively established that the high-voltage filter capacitors have been discharged to a *known* safe level.



WARNING: Safety Ground

Improper grounding of this equipment can result in electric shock. The TWTA must be operated only with a line cord with a safety ground wire. It is the user's responsibility to ascertain that the power connector is properly wired and that the power outlet is grounded.



WARNING: Explosive Atmosphere

To avoid explosion, never operate this TWTA in an explosive atmosphere. This equipment is not certified for operation in an explosive atmosphere.

3.2 INSTALLATION

3.2.1 Unpacking

Upon receiving the TWTA, unpack the unit and inspect it for obvious signs of external damage. If damage is observed, notify the carrier and contact an authorized service representative.

Save and store the shipping container in case the unit needs to be returned in the future for calibration or repair.

3.2.2 Mounting

The TWTA may be operated as a standalone benchtop unit, or it may be installed in a 19" rack.

If rack mounting is desired, first remove the amplifier from the cabinet, then install the amplifier in the rack.



CAUTION:

Due to the weight of the unit, the removal of the amplifier from the cabinet or rack is a two person operation.

Before removal disconnect power, RF, and any other interface connectors. On the rear of the unit, remove the six screws used to connect brackets to amplifier. On the front of the unit, remove the four screws holding the front panel to the cabinet. Carefully slide the amplifier out of the front of the cabinet.



CAUTION:

Never rack mount the TWTA using the front panel alone. The chassis is likely to be damaged unless its weight is supported. Bottom support rails must be provided in a rack mount configuration.

See Figure 3-1 (on the next page) for the locations of threaded holes which may be used for supplementary support of the rear of the TWTA.

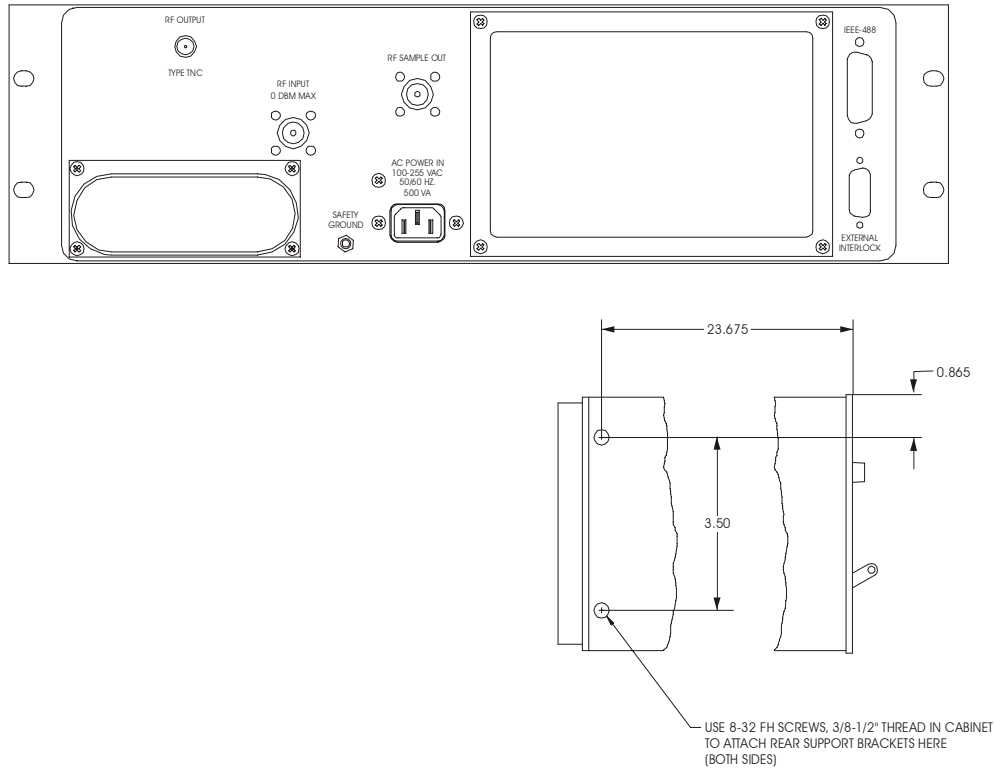

Figure 3-1. Rear View of HPA, Rack Mounting Configuration

If bottom supports are used for rack mount installation of multiple units, the amplifiers should be separated vertically by at least 1 3/4 inches. This will allow room for necessary support rails and facilitate installation and removal of the units.

3.2.3 Cooling Requirements

The TWTA is provided with a cooling fan. It is important that air movement around the rear of the unit be unobstructed.



CAUTION:

For either bench or rack mounting, do not position the TWTA in such a way that the air intake or outlet are blocked, or that the exhaust flow is directed into the intake. See Paragraph 3.5 for location of air intake and air outlet. If the unit is rack mounted, make sure that the intake air is 45°C or below. If necessary, fabricate a short duct to direct the hot exhaust air out of the rack enclosure. Great care must be taken to minimize any flow restrictions. Avoid mounting heat-producing equipment in the same rack, especially below the TWTA. Failure to provide adequate cooling can result in the unit's shutting down from overtemperature conditions.

The TWTA dissipates approximately 500 watts when in the operate mode.

3.2.4 AC Line Power Connections

AC line power connection to the TWTA is made at the AC inlet J1, which is a female IEC-320 connector. A line cord suitable for the type of AC outlet used, and consistent with local electrical codes, must be obtained to mate with J1. Minimum wire size for the line cord is 18 gauge.

TWTAs destined for the North American market are provided with a terminated 3-wire cord. It plugs into normal 120 VAC single phase outlets. The amplifier will operate from any line voltage between 99 and 260 VAC.

3.2.5 RF Output Connections

The RF output coaxial connector is type TNC female.



CAUTION:

Never operate the TWTA without a matched output load rated for at least 100 watts, continuous. The TWTA is not provided with an output isolator. Full reflected power may irreparably damage the TWT. Even with no drive, “looping” oscillation can result in RF output high enough to damage the tube if it is operated without a load. The VSWR detection and foldback circuit is provided to protect the tube from *progressive* failure or mismatch of the output load; it should not be relied on for protection from the absence of a load.

If an external isolator is installed at the output of the TWTA, either the isolator should have a load capable of dissipating the full output of the TWTA or the isolator load should be provided with a temperature sensing switch. The temperature switch should be normally closed, self-resetting, and with a temperature rating such that there is no possibility of damaging the load by overheating before the switch opens. The TWTA may be interlocked with the switch by connecting it between pins 3 and 4 of the external interlock connector (J2). If no external isolator is used, install a jumper between pins 3 and 4. See section 3.2.6, External Interlock Connector, below.

3.2.6 External Interlock Connector

The TWTA is provided with an external interlock capability via a 15-pin female D-sub connector, J2. To enable the high voltage power supply, it is necessary to provide continuity between J2 pins 3 and 4. If the amplifier shuts down because the interlock was opened, it will be necessary to reset the system to return to standby (see *System shutdown screen* in Section 3.4). There is an internal jumper between J2 pins 1 and 2; a continuity check through these pins can be used to verify the presence of the amplifier in the instrumentation system. Users may adopt this interlock feature to disable the RF output for either equipment protection or as a backup for personnel protection.



CAUTION:

Do not rely on the external interlock for personnel protection. The intent of the external interlock feature is to disable the RF output for equipment protection. Use proper operating and safety procedures to insure that power is removed for personnel safety.

3.3 FRONT PANEL FEATURES

Refer to Figure 3-2 below.

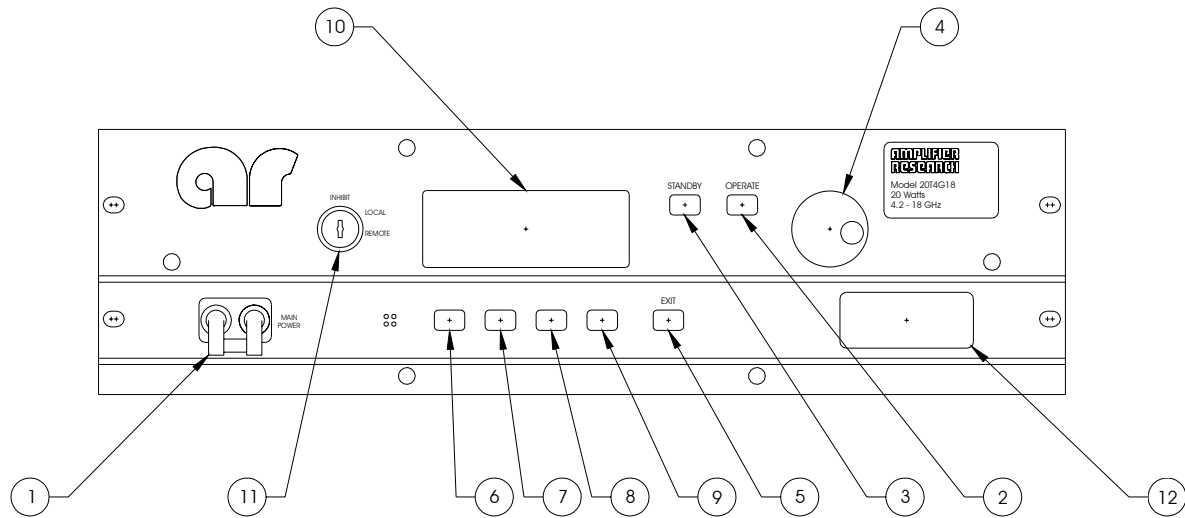

Figure 3-2. Front Panel Features

Table 1. Front Panel Features

Item	Title	Function
1	MAIN POWER	Switchable 16 A. circuit breaker; connects primary power to power supplies.
2.	OPERATE	Push-button; turns on high voltage and SSA when all faults and heater delay are cleared.
3.	STANDBY	Push-button; shuts off SSA and turns off high voltage.
4.	ADJUST	Rotary knob used as an input device to change values of a variety of parameters.
5.	EXIT	Push-button; terminates various menu selection routines and returns to the previous menu level.
6-9.	S1...S4	"Soft Key" push-buttons; various menu selection functions.
10.	Display	Displays numerous parameter values and fault messages.
11.	Keylock Switch	Allows operator to inhibit the TWTA, to enable front panel control, or to enable computer control.
12.	Emergency switch cover	Provides access to emergency bypass switches, which permit manual control of the amplifier.

3.4 FRONT PANEL DISPLAY AND SOFT KEYS

The purpose of the front panel display is to permit the operator to access extensive information about the condition and operation of the TWTA. To accomplish this, a number of informational screens are programmed. It is important for the operator to be able to select the screen with the required information. Screen selection is accomplished by pressing an appropriate soft key or by pressing the EXIT key. When a soft key is active, its function is displayed on the bottom line of the display. Figure 3-3 provides a “roadmap” for navigating between the screens.

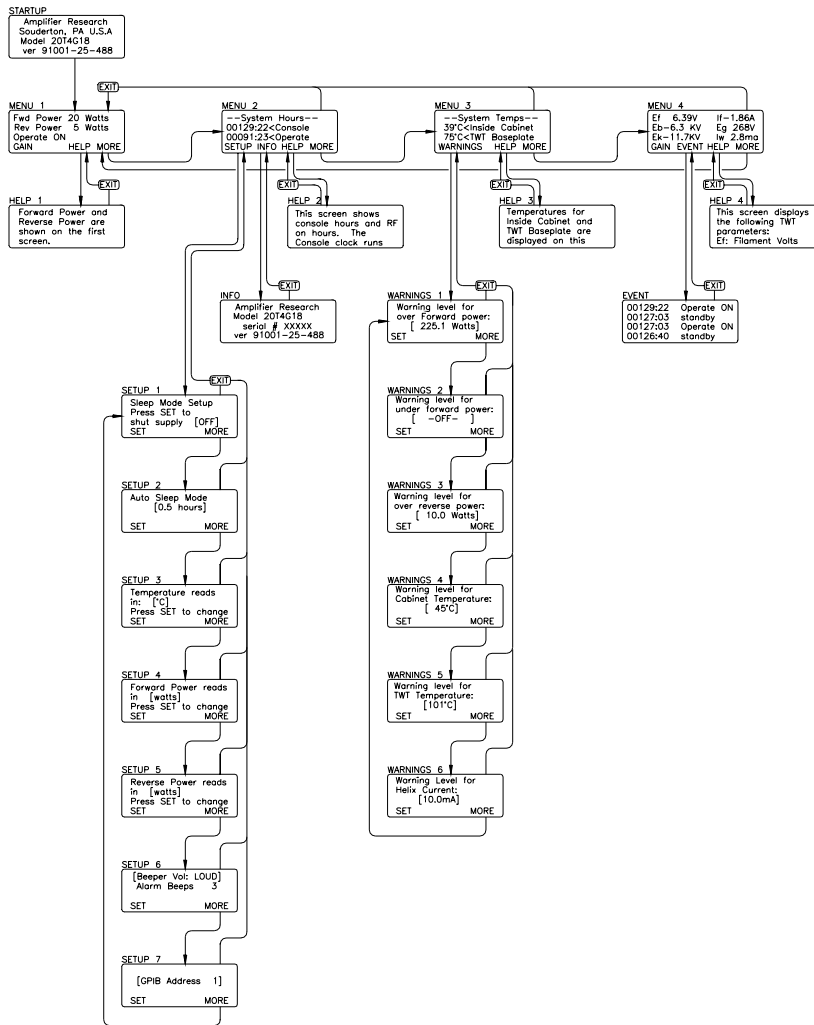

Figure 3-3. Front Panel Display Screens

Menu screens - The screens at the highest level are called menu screens. There are four menu screens. At power on, the MENU 1 screen is displayed. Each of the menu screens has the soft key S4 labeled MORE. The MORE key (S4) causes the next menu screen to appear. From MENU 4, MORE causes MENU 1 to reappear. In short, MORE permits scrolling through the menu screens. The EXIT key returns display to MENU 1 from any other menu screen.

The menu screens display system status and parameter levels. They are configured as follows:

MENU 1	Forward power (watts, dBm or bar graph)
	Reverse power (watts, dBm or % of forward power)
	System status (if a latched fault exists, MENU 1 is displayed with the system shutdown message)
MENU 2	Console hours (active when AC power is on)
	Operate hours (active when HV is on)
MENU 3	Cabinet temperature (°C or °F)
	TWT baseplate temperature (°C or °F)
MENU 4	Heater voltage (Ef)
	Heater current (If)
	Collector voltage (Eb)
	Cathode voltage (Ek)
	Helix current (Iw)

Help Screens - On each of the menu screens, soft key S3 is labeled HELP. If S3 is selected, a message describing the functions of that screen will be displayed. Use the ADJUST knob to scroll through the message. The EXIT key will return you to the screen from which the help screen was called.

Setup Screens - From MENU 2, S1 (labeled SETUP) selects the first of several setup screens, SETUP 1. This allows the user to manually shut off the heater power supply and put the HPA into “Sleep Mode” (see below). Pressing S1 (SET) toggles between On and OFF. Pressing MORE again brings up the SETUP 2 screen, which allows the user to change the Auto Sleep Mode timer setting. Pressing SET will change the timer options in half hour increments from 0.5 to 3.0 hours. Pressing MORE again will save the timer setting and bring up the SETUP 3 screen, which toggles the display of temperature parameters between Fahrenheit and Celsius degrees. Pressing S1 (SET) changes the selection. The setting displayed when the screen is exited will be retained. Pressing MORE again brings up the SETUP 4 screen, which allows a choice of displaying forward power in watts, dBm or bar graph. Pressing MORE a third time brings up SETUP 5, which allows a choice of watts, dBm, or % of forward power for displaying reverse power. MORE brings up SETUP 6, which allows entering the desired number of alarm beeps and the desired beep volume. S1 (SET) toggles between parameters, and the adjust knob is used to enter the data. Setup 7 allows the IEEE-488 address to be set. Setup 8 allows selecting between pulsed or CW operation. The SET button toggles between the two. MORE returns you to SETUP 1. EXIT returns you from any of the setup screens to MENU 2.

Sleep Mode - The Sleep Mode feature allows the *user* to selectively shut off the heater module of the power supplies. This can be done manually through the front panel or remotely via the computer interface. This is typically used during extended periods of *remote* operation to improve tube life, by turning off the filaments (Sleep Mode activated). This eliminates excessive STANDBY hours on the TWTs while still permitting remote capability to turn on the amplifier.

To activate Sleep Mode locally:

Press the MORE soft key to get to MENU 2. At MENU 2 press the SETUP soft key to get to SETUP 1. At SETUP 1 press SET to activate Sleep Mode (turn heater and fan off). The system will ask “are you sure?” Press SET again.

After activating the Sleep Mode:

Screen will display “Cooling On” while heaters cool down. ”System Off” notifies user that the amplifier is in Sleep Mode

To deactivate Sleep Mode locally:

Press the ON soft key to de-activate Sleep Mode. Amplifier will return to MENU 1. When de-activating the Sleep Mode the heaters will require approximately a 5 minute heater time delay. Wait the full 5 minutes prior to selecting OPERATE.

For remote activation of Sleep Mode or to set the Auto Sleep Mode timer remotely see Table 3 in Section 3.8.

Warnings Screens - From MENU 3, S1 (labeled WARNINGS) selects WARNINGS 1 which allows the operator to enter the maximum forward power. The existing value is between brackets[]; pressing SET puts arrows >< around the value, indicating that the adjust knob is active. The effect of the warning setpoint is as follows: if the forward power exceeds the setpoint, the audible alarm will sound (if configured in SETUP 3).

This warning will be repeated every thirty seconds until the over forward power condition is cleared. In addition, a warning message will appear on line 3 (the status line) of MENU 1. In the event that the alarm is heard, the operator should go to MENU 1 to determine the cause.

Pressing more brings up WARNINGS 2, which allows the under forward power setpoint to be entered. Adjusting this to the minimum value causes -OFF- to be selected, disabling this alarm.

In WARNINGS 3, the maximum reverse power level is set. Note that these are warning levels at which the beep sounds; the actual maximum reverse power level that generates a system fault is set in hardware in the TWT power supply HPA Logic and Control module (A16485).

MORE brings up WARNINGS 4, which allows input of the maximum cabinet temperature. Entering this parameter is performed as above.

MORE brings up WARNINGS 5, identical to the previous screen except that it deals with the maximum TWT collector block temperature. If either parameter exceeds the setpoint, the audible alarm will sound every 30 seconds (if configured), and a warning message will appear on line 3 of MENU 1.

From WARNINGS 5, MORE brings up WARNINGS 6, which permits setting the maximum helix current. Any helix current above this setpoint will result in an audible alarm (if configured), repeated every 30 seconds; and a warning message is displayed on the status line of MENU 1.

Pressing MORE again returns display to WARNINGS 1. As before, pressing EXIT from any of the warnings screens returns display to MENU 3.

Info Screen - From MENU 2, S2 (labeled INFO) selects a screen that displays the RF sample port calibration factors at various frequencies across the band. In addition, this screen displays the model number, serial number and firmware revision information which may be required by a service representative when providing technical assistance. The EXIT key returns the display to MENU 2.

Event Screen - From MENU 4, S2 (labeled EVENT) provides a display of events logged by the control system. These events include AC power-up, heater warm-up, change from standby to operate, faults, and resets. The events are stored in a first-in-first-out (FIFO) software buffer that has room for 100 events; as new events are logged, the older ones are discarded.

System Shutdown Screen - In the event of a system shutdown due to a latched fault (i. e., a fault such as body overcurrent or power low line that requires a reset), the MENU screen is replaced by a screen indicating the nature of the fault. Softkey S4 (labeled OK) is implemented as a reset key; pressing S4 brings back the MENU screens. Line 3 of MENU 1, which normally displays the operational state of the TWTA, is used as a fault display line until the fault is cleared. When the fault clears the system will automatically resume the standby state and high voltage on will be enabled once again.

Factory Service Screens - A number of screens intended for factory service and calibration are behind passwords and are not accessible to the user.

System Malfunction Screens - A number of screens are reserved to display error messages. These messages are not normally seen and indicate a malfunction of the TWTA. System malfunction messages include the following:

- Database corrupt
- Communication failure
- Cannot restore
- CU line voltage too low to operate. System shutdown

In the event that one of these appears, shut off the TWTA and contact an authorized service representative before proceeding.

CAUTION:



Attempts to operate the TWTA despite control unit problems may result in loss of the static RAM database and calibration information.

3.5 REAR PANEL FEATURES

See Figure 3-4 below

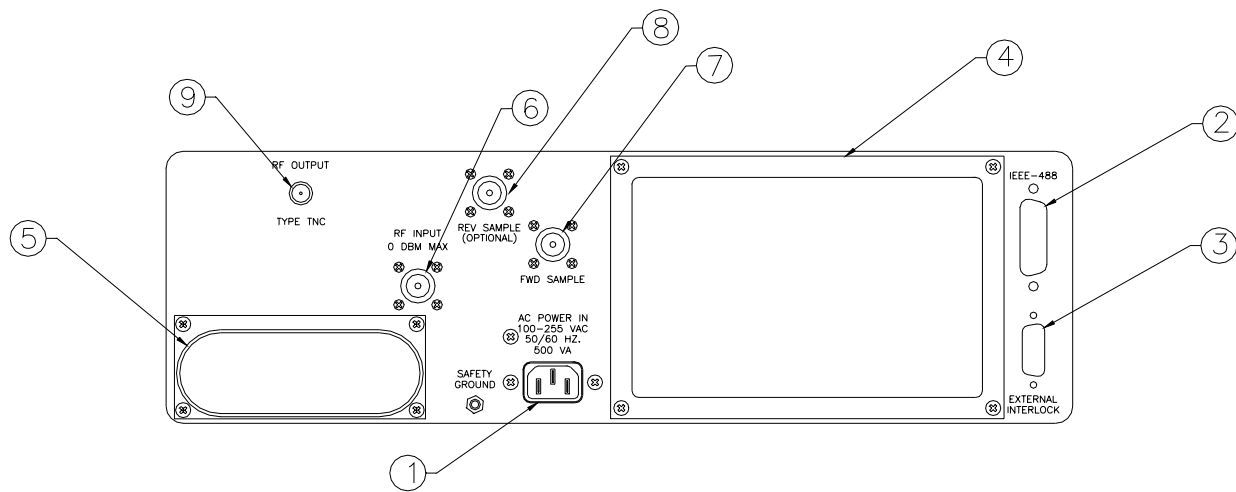

Figure 3-4. Rear Panel Features

Table 2. TWTA Rear Panel Features

Item	Title	Function
1.	AC POWER IN	AC power input connector: IEC-320 connector
2.	IEEE-488	Remote control connector: 24 pin hermaphrodite
3.	EXTERNAL INTERLOCK	Connector to remote temperature switch protecting the isolator load: D-sub 15-pin female
4.	—	Cooling air intake.
5.	—	Cooling air outlet.
6.	RF INPUT	RF input; N female connector
7.	FORWARD SAMPLE	RF sample type N (female)
8.	REVERSE SAMPLE	RF sample type N (female) - OPTIONAL
9.	RF OUTPUT	RF output: TNC female connector

3.6 INITIAL TURN ON AND WARM-UP PROCEDURE

Install the TWTA as discussed in section 3.2 Provide an RF generator to the RF input Type N connector A1J1. Set RF generator level below -50 dBm and set desired frequency in specified range. Connect a load suitable for 100 watts continuous operation to the output waveguide. The load VSWR should be less than 2.0:1 A power meter and suitable attenuators may be connected to the RF sample port A1J2. (Refer to RF sample port calibration factors on the rear of the unit or on the *Info* screen in MENU 2). These show the relation between the amplifier output power and the RF sample port power as a function of frequency. When only the power of the fundamental frequency is to be measured and when operating near rated power use; filters, a frequency selective receiver, or a spectrum analyzer to reduce the harmonic content of the measured level.

Set keylock to LOCAL.

Switch on the MAIN POWER circuit breaker. The fan will operate. The front panel display will show several identification messages and then the MENU 1 screen. The third line will indicate that the heater time delay is active.

Allow the heater warm-up delay to expire. Line three will indicate OFF/READY.

Push S4 (MORE) three times to go to MENU 4. Verify that the heater voltage and current are near their nominal levels. The values of these parameters at the time the TWTA left the factory are logged on the test data sheet.

Push the OPERATE push-button. You will now see the cathode and the collector voltages rise. Verify that the collector and cathode voltages are near nominal. The helix current should be close to the nominal value for no RF drive. Then push MORE or EXIT to go back to MENU 1.

Set the TWTA gain to maximum. Adjust the RF generator to slowly increase the RF drive toward 0 dBm to reach the desired FWD PWR on the display and power meter (connected to sample port). The forward power bar graph will become active, with maximum length when peak power output is achieved. Best performance is obtained when the input RF drive is set at or just below the level which causes peak power output. Do not set input drive above 0 dBm (Input drive above +20 dBm may damage the unit). The reverse power level should remain below 10% of the forward power, assuming that the load is properly matched.

An alternate procedure is to pre-set the TWTA gain to minimum, set the RF generator to 0 dBm and then slowly increase the TWTA gain to set the desired RF output level.

Observe that the helix current is sensitive to the RF drive level of the TWT. It is at a minimum with no RF drive. The helix currents with no drive and with rated RF output mid-band are logged on the test data sheet. The value of the helix current is a good qualitative indicator of RF drive present.

To shut the system down, turn down the RF generator level below -50 dBm and press STANDBY. Allow the TWTA to cool down until the TWT temperature drops below 70°C, then turn off main power

3.7 EMERGENCY BYPASS OPERATION

For reference, see schematic 10-24830-002 in section 5.2.

The TWTA is provided with a means of operating the amplifier manually in the event that there is a failure of the control module and it is imperative that the amplifier remain on line.



CAUTION:

Emergency bypass operation disables certain protective and diagnostic features. For this reason, the emergency bypass mode of operation should be used only when the control unit fails and when it is essential to remain on line.

To access the manual controls, remove the two 4-40 screws securing the emergency switch cover on the front panel. Emergency bypass mode is selected by pushing the left-hand switch (S1) to the left. The center switch (S2) toggles between high voltage on (left) and high voltage off (right). The right-hand switch (S3) selects between solid state amplifier (SSA) active (RF on) in the left hand position, and SSA off (RF off) in the right-hand position. There is a manual control for the gain adjustment as well. This is a flat, square single-turn pot (R1).



CAUTION:
Do not adjust 20-turn pot R11; its function is to set the foldback RF output level, and it is calibrated at the factory.

3.8 REMOTE IEEE-488 OPERATION

The TWTA is provided with a communication interface that conforms electrically to the IEEE-488 standard. It permits remote emulation of OPERATE, STANDBY, and RESET push-buttons as well as access to parameter measurements, system faults, gain adjustment, and control unit status. The following tables summarize the commands and the return codes.

Table 3. Catalog of IEEE-488 Commands

Command	Function	Units	Response format
RDSTAT	Returns status code of processing of previous command (see Table 4)		STATUS=[]
RDFLT	Returns system fault code (see Table 5)		flt=[]
OPERATE;	Emulates OPERATE push-button		
STANDBY;	Emulate STANDBY push-button		
POWER:OFF;	Emulate STANDBY push-button		
RESET;	Emulates RESET softkey		
RDS/N	Returns serial number		s/n=[]
RDCONHR	Returns console hours		ConHr=[]
RDRFHR	Returns RF hours		RfHr=[]
RDEK	Returns cathode voltage	KV	Ek=[]
RDEB	Returns collector voltage	KV	Eb=[]
RDEF	Returns heater voltage	V	Ef=[]
RDIF	Returns heater current	A	If=[]
RDIW	Returns helix current	mA	Iw=[]
RDTMPTWTF	Returns TWT temp (°F)	°F	TWTF=[]F
RDTMPTWTC	Returns TWT temp (°C)	°C	TWTC=[]C
RDTMPPSF	Returns power supply temp (°F)	°F	PSF=[]F
RDTMPPSC	Returns power supply temp (°C)	°C	PSC=[]C
RDTWTOTF	Returns TWT overtemp warning setpoint (°F)	°F	TWTOTF=[]F
STWTOTF	Sets TWT overtemp warning setpoint (°F)	°F	
RDTWTOTC	Returns TWT overtemp warning setpoint (°C)	°C	TWTOTC=[]C
STWTOTC	Sets TWT overtemp warning setpoint (°C)	°C	
RDPSOTF	Returns power supply overtemp warning setpoint (°F)	°F	PSOTF=[]F
SPSOTF	Sets p. s. overtemp warning setpoint (°F)	°F	
RDPSOTC	Returns p. s. overtemp warning setpoint (°C)	°C	PSOTC=[]C
SPSOTC	Sets p. s. overtemp warning setpoint (°C)	°C	
RDIWOC	Returns helix overcurrent warning setpoint	mA	IwOC=[]
SIWOC	Sets helix overcurrent warning setpoint	mA	
RDLOGIC	Returns logic state code (see Table 6)		Sys=[]
RDA	Returns gain	%	A=[]
SA	Sets gain	%	

Command	Function	Units	Response format
RDHTDREM	Returns remaining heater time delay	sec.	HTD=[]s
RDPOD	Returns forward power out (dBm)	dBm	Po=[]dBm
RDPOW	Returns forward power out (W)	watts	Po=[]W
RDPRD	Returns reverse power out (dBm)	dBm	Pr=[]dBm
RDPRW	Returns reverse power out (W)	watts	Pr=[]W
RDPOHID	Returns over forward power warning setpoint (dBm)	dBm	Pohi=[]dBm
SPOHID	Sets over forward power warning setpoint (dBm)	dBm	
RDPOLOD	Returns under forward power warning setpoint (dBm)	dBm	Polo=[]dBm
SPOLOD	Sets under forward power warning setpoint (dBm)	dBm	
RDPOHIW	Returns over forward power warning setpoint (W)	watts	Pohi=[]W
SPOHIW	Sets over forward power warning setpoint (W)	watts	
RDPOLOW	Returns under forward power warning setpoint (W)	watts	Polo=[]W
SPOLOW	Sets under forward power warning setpoint (W)	watts	
RDPRHID	Returns over reverse power warning setpoint (dB)	dBm	Prhi=[]dBm
SPPRHID	Sets over reverse power warning setpoint (dBm)	dBm	
RDPRHIW	Returns over reverse power warning setpoint (W)	watts	Prhi=[]W
SPRHIW	Sets over reverse power warning setpoint (W)	watts	
SYSTEM:ON	Emulates pressing the System ON button from System OFF (Exit Sleep Mode)		
SYSTEM:OFF	Emulates pressing the Power Save button. (Enter Sleep Mode)		
RDHTRAUTOOFF	Returns heater auto off delay	hours	
SHTRAUTOOFF	Sets heater auto off delay (see Table 9)		
*IDN?;	Returns the product model number		[]
*STA?;	Returns status string (see Table 7)		[]
*STB?;	Returns status string (see Table 8)		[]

Table 4. Catalog of Status Codes

(The RDSTAT command causes the TWTA to return a string in the form STATUS=[code], where [code] is an ASCII number whose meaning is given below)

Status Code	Meaning
0	No command was given.
1	Last command was successful.
2	Last command is in process.
3	Last command failed to complete. Time-out.
10	Last command failed. Invalid command.
11	Last command failed. Data was unparseable.
20	Last set command failed. Data was beyond high limit.
21	Last set command failed. Data was beyond low limit.
22	Last set command failed. Data was out of range
23	Last set command failed. Data was wrong polarity
50	Last command failed. Local system does not have remote enabled.
51	Remote system is not ready to accept commands.
60	Command is not allowed in current system state.
901	Assert error: invalid table argument*
902	Assert error: invalid calibration*

* Please call a service representative if you observe this error.

Table 5 Catalog of Fault Codes Returned by RDFLT Command

(The RDFLT command causes the TWTA to return a string in the form flt=[code], where [code] is an ASCII number whose meaning is given below).

Fault Code	Meaning
0	No fault
7	System Fault
8	High Line
9	Low Line
10	Cathode overvoltage
11	Body overcurrent
12	Cathode undervoltage
13	Heater undervoltage ("Fil not ready")
14	Heater overcurrent ("Fil o/current")
15	Collector undervoltage
16	Inverter fault
17	Internal interlock open
18	Tube arc
19	TWT (hardware) overtemperature
20	Cabinet (hardware) overtemperature
23	Over reverse power
49	TWT (software) overtemperature
50	Cabinet (software) overtemperature

Table 6. Catalog of System State Codes

(The RDLOGIC command causes the TWTA to send a string containing an operational state code consisting of 4 ASCII characters representing hex digits. The response is in the form "Sys:[w][x][y][z][eol]" where the hex values of [w],[x],[y] and [z] are formed as shown below)

z bit	Meaning
0 (LSB)	High voltage on
1	Transmit on
2	Remote mode
3 (MSB)	Fault

y bit	Meaning
4 (LSB)	Heater time delay expired
5	Under forward power warning
6	Foldback active
7 (MSB)	Inhibit mode

x bit	Meaning
8 (LSB)	External inhibit
9	Interlock open
10	(not used)
11 (MSB)	(not used)

w bit	Meaning
12 (LSB)	(not used)
13	Sleep Mode Active
14	(not used)
15 (MSB)	(not used)

Table 7. *STA?; Response Codes

(The command *STA?; causes the TWTA to send a string indicative of the current system state)

*STA?; response	Meaning
SLEEP	Sleep Mode active (heater off)
WARM-UP	System is in heater time delay.
STANDBY	System is ready to allow high voltage on
OPERATE	High voltage is on and beam is on
FAULT	High voltage is off and system requires reset

Table 8. *STB?; Response Codes

(The command *STB?; causes the TWTA to send a string containing an operational state code consisting of 2 ASCII characters representing hex digits. The response is in the form “STATUS:[x][y][eol] ” where the hex values of [x] and [y] are formed as shown below)

x bit	Meaning
1	Mode switch; always 1 (reset)
2	Blank switch; always 1 (off)
3	Blank status; always 0 (off)
4	Not used; always 0

y bit	Meaning
1	Power status; always 1(power on)
2	Standby status; 0 if not in standby, 1 if in standby
3	Operate status; 0 if not in operate, 1 if in operate
4	Fault status; 0 if no fault, 1 if fault exists

Table 9. Catalog of Heater Auto Off Time Delay Codes

Argument	Meaning
0	0.5 hour heater auto off time delay
1	1.0 hour heater auto off time delay
2	1.5 hour heater auto off time delay
3	2.0 hour heater auto off time delay
4	2.5 hour heater auto off time delay
5	3.0 hour heater auto off time delay

Command syntax is in this form:

<command mnemonic> <parameter> <carriage return>

where:

<command mnemonic> consists of one of any valid command found in Table 3.

<parameter> (as applicable) consists of one ASCII “space” character followed by a number.

<carriage return> consists of an ASCII carriage return.

All commands are case sensitive.

The system will return parameter values, fault codes, and status codes regardless of whether remote is enabled. The parameter value is returned as a string of 20 characters or less, consisting of a label, “=”, and a value. For example, outputting the command RDEF to the TWTA would result in the TWTA sending back the string “Ef=6.03” (assuming the heater voltage is 6.03 volts). Units are usually not returned; see table 3 for the units.

If remote is not enabled, set commands and commands to the system logic (i. e., OPERATE; or STANDBY; or RESET;) will not be accepted.

It is recommended that the RDSTAT command be used to provide the host program with a report on how a command was processed.

A small sample program that can send commands and receive the strings returned by the TWTA is included in section 5.6. It is written in Hewlett-Packard's "Rocky Mountain" BASIC. The program assumes that the IEEE-488 bus is at address 7 and that the address of the TWTA is 01.

Remote operation is determined by the application (software) program in the system controller. This application program will aid the user in generating the Command Codes and displaying/monitoring the Status Codes. Consult the application program users instructions for Remote operation procedure.

The application program should issue only one string at a time. After each functional command is issued the status should be checked to ensure that the command has been properly executed. The application program should allow sufficient time for the function to be completed before checking the status.

The application program should facilitate checking the status just prior to issuing a command, since the status could have been changed by a fault condition of the amplifier or by operator activation of the amplifier. Periodic checking of the status is also recommended.

3.9 TWTA GENERAL CONSIDERATIONS

This section is intended to offer some guidelines regarding operation, storage and use of Amplifier Research TWTAs.

Storage: TWTAs, as with other electronic equipment, are best stored in a benign environment at reasonably constant temperature. Service life is not improved by periodic operation.

Availability: For critical missions, and after long periods of storage, it is recommended that TWTA operation be checked sufficiently in advance of the mission to permit repair if required. Though service life is not improved by periodic operation, users experiencing amplifier trip due to body over current may benefit by periodically operating a unit with high voltage and grid on, but no RF drive. Such operation for about one hour on a weekly basis should effectively reduce nuisance tripping. Since the cathode structure has finite life, extended periods of non-functional operation of TWTAs is not recommended. An alternate approach, if periodic trip off has been observed, is to operate the unit without RF input for 1-2 hours before planned functional operation, resetting the unit after occasional trip off.

Cooling during Operate Mode: AR TWTAs have their air outlets and inlets on the rear panels. It is important to prevent the heated air, which is expelled from the TWTA's air outlets, from being recycled into the air inlets. Applications should have a clearance behind the TWTA of at least two feet for single bench top units and at least three feet for the higher power units, or the heated air should be ducted away.

Operation in Standby Mode: Standby mode for TWTAs readies the unit for operation. In this mode the filaments are on but the high voltage is off. TWTAs should not be left in this Standby mode for extended periods. Where practical, operational procedures should limit the time on Standby mode to less than approximately one hour. (See *Explanation of...*, below)

Operate Turn on: When selecting the Operate mode, when high voltage is first turned on, there may be some internal TWT arcing which can cause protective circuits to deselect the Operate mode, thereby returning the unit to the Standby mode. There may be a report of body over-current fault. In either case, if there is no other contraindication, the Operate mode may be selected again. This procedure maybe repeated, if needed up to 25 times, until the Operate mode is actually set. If this condition persists, contact Amplifier Research Service for additional assistance. (See *Explanation of...*, below)

Noise Power Density (NPD): TWTAs produce rf noise over their operating frequency range, as specified by the Noise Power Density (NPD). This noise is significantly higher than the noise produced by typical solid

state amplifiers, and is inherent in present TWTAs. The noise may surprise users new to TWTAs when it accumulates and results in a significant indication in a broadband measurement device – such as a power meter or field probe. The error produced by this indication is not significant when operating near rated TWA power levels, but may cause difficulty when trying to operate high power TWTAs at low output power levels.

For example, consider a hypothetical typical NPD of -76 dBm/Hz, from a 4 GHz bandwidth amplifier. A broadband detector might see the NPD as $[-76 \text{ dBm/Hz} + 10 (\log 4 \times 10^9) \text{ BW factor} = -76 + 96 =] +20$ dBm, or 0.1 watts. This power is insignificant for a user operating at 200 watts (+53 dBm), but may be very noticeable to a user trying to operate below 1 watt (+30 dBm). [One watt is 0.5% of (23dB below) rated power for a 200 watt amplifier.] A field probe user who obtains a 200 V/M field with 200 watts, may see a field as high as $[53\text{dBm} - 20\text{dBm} = 33\text{dB below } 200 \text{ V/M} =] 4.5$ V/M due to this hypothetical NPD.

For these applications the use of a lower power amplifier is highly recommended, especially when considering safety issues. Alternatively, additional power loss in the form of an added high power microwave attenuator, or preferably an increased space loss for radiated fields, may be used to lower the noise received by the broadband measurement device.

Explanation of Limiting the Time in Standby mode and of Repeated Operate Selection.

Traveling wave tubes tend to get “gassy” if they are left in a “Standby” mode for extended periods of time. In this “Standby” mode, the heater (filament) is on but there is no high voltage applied to the collector (or high voltage is applied to the collector but the grid is off). This is the normal state after a tube’s warm up time, just prior to entering the “Operate” mode.

In this state the cathode end of the TWT is heating up but the electron “Beam” is off. In other words, there is no cathode current. As the cathode heats up, gas trapped in the structure of the tube can be released, thus corrupting the vacuum of the tube. If the tube become too “gassy”, arcing may occur when the high voltage is fully applied in the “Operate” mode. Another possible failure mode is a body over-current fault when the beam is turned on and the tube is “gassy”.

Occasional arcing is normal for a TWT. The support components are designed to handle this, protecting both the TWT and its support circuitry. However, if the tube arcs two or three times in rapid succession, or worse yet repeatedly, a fault will be sensed that will shut the high voltage off, thus removing the unit from “Operate” status. The remedy usually recommended is to repeat the selection of the “Operate” mode until the unit remains in “Operate”. It has been found that most of the faults that can be cleared by this method will be cleared within 25 attempts to enter the Operate mode.

Once the tube is operating normally, gas will continue to evolve at a slow enough rate that the TWTA will not fault. This happens because the gas in the tube will interact with the beam and become ionized. As the electrons in the beam hit the gas molecules they ionize the gas, at which point it is accelerated into the collector structure and “buried” deep enough so that it ceases to be a problem.

To preclude this gassing problem, and thus reduce the need for repeating the “Operate” selection, it is recommended that the time in “Standby” be limited – to about one hour. Extended periods in “Standby” may result in an inability to clear the fault by this method. In this case, service measures may be needed to correct the unit. Thus, users should reduce the likelihood of occurrence of this problem by limiting the amount of time in the “Standby” mode.

The service measures involve pulsing of the tube beam current and gradually increasing the duty of the pulsing until the unit will operate continuously. Note that a similar condition can exist for tubes with grids when the TWTA is in the “Operate” mode (high voltage is on) but gating (control) input is set so that the grid turns off the TWT beam current. Operational procedures should also limit the time in this mode.

4. MAINTENANCE

The TWTA does not require routine scheduled maintenance. The only moving parts are the elements of switches, relays and blowers. Preventive maintenance is recommended in Paragraph 4.3.

The TWTA is basically a factory repairable unit. However, since limited logic schematics and partial parts information is supplied in this manual (Section V) some user service organizations may choose to perform their own corrective maintenance. **Warnings and Cautions should be observed.**

4.1 SAFETY WARNING



WARNING:

Service work must be performed only by technicians thoroughly familiar with the high voltages present in microwave tube amplifiers in general, and with this equipment in particular.

Never handle the TWT leads or the high-voltage connectors unless it has been positively established that the high-voltage filter capacitors have been discharged to a *known* safe level.



CAUTION:

A malfunctioning power supply can cause damage to the TWT. If you are troubleshooting the TWTA, remove the TWT and substitute suitable loads to prevent damage to the TWT.

4.2 UNAUTHORIZED REPAIRS



CAUTION:

Unauthorized repairs or modification of this product during the warranty period may void the warranty. In the event that the TWTA malfunctions while it is still under warranty, always contact an authorized service representative.

4.3 PREVENTIVE MAINTENANCE

The RF characteristics and power supply voltages and currents of the TWTA should be logged on a regular basis. Maintenance should be performed if significant deviations from the logged values appear. If the unit is under warranty, contact an authorized service representative if impaired performance is suspected.

If there is accumulated dust on the air intake grill, clean it with dry compressed air.

If significant dust has been noted on the air intake grill, it may be desirable to vacuum the dust and debris from inside the enclosure.

To open the enclosure:

1. Remove the amplifier from the cabinet or rack as follows:

NOTE: Due to the weight of the unit, the removal of the amplifier from the cabinet or rack is a two person operation.

Disconnect power, RF, and any other interface connectors. On the rear of the unit, remove any screws used to connect brackets to the amplifier. On the front of the unit, remove the four screws holding the front panel onto the cabinet. Carefully slide the amplifier out of the front of the cabinet.

2. Remove the 12 screws that secure the lower cover and the 12 screws that secure the upper cover. Remove the covers to gain access to the interior of the TWTA.

Vacuum dust and debris from inside the enclosure. Clean dust from the TWTA and its flying leads. Remove any dirt from around the three high voltage connectors. While the cover is off, check for loose wires, components or fasteners.

Reassemble in the reverse order.

4.4 TROUBLESHOOTING

Symptom	Possible cause
TWT or power supply overtemperature	Air inlet filter dirty Collector heat sink dirty Inadequate clearance behind TWTA High air inlet temperature Defective blower or power supply
No response when main power turned on	Panel open interlock switch open
Control module display does not come up; unit does not beep when powered up	Shorted or defective control module power supply Control module failure
Control module does not boot	EPROM(s) missing.
Control module "datalink failure" or "Communication Problem" error appears	HPA interface failure. Fiberoptic link failure ± 15 VDC supply failure
Heater power supply does not come up	Defective low voltage power supply module Defective heater power supply module
No high voltage	Open external interlock Keylock switch on "INHIBIT" or "REMOTE" Defective high voltage power supply.
Voltages normal, but no RF output, helix current low	No RF input Defective remote control board Defective SSA Gain turned down

After review of the symptoms of the failure, the user may want to check for a loose connector or component especially after rough handling of the unit. Look externally for physical damage and internally for unmated or loose parts.

The service technician should become familiar with the internal mechanical construction to permit correct re-assembly. Limited troubleshooting may be conducted, with caution, based on the failure symptom and an understanding of the logic/schematic diagrams.

4.5 NON-REPAIRABLE MODULES

The High Voltage Diode/Cap Assembly (A21455-100), the High Voltage Filter Assembly (A21454), and the Heater Supply (A10010-000) are encapsulated modules and are not repairable. Contact an authorized service representative if replacement modules are needed.

5. TECHNICAL DOCUMENTATION

NOTE: The purpose of this technical documentation section is to provide a guide to the TWTA for technician-level servicing. It is intended for use by qualified technical personnel who must troubleshoot and repair the TWTA in the field. Such repairs are typically limited to replacement of modules or major components. For this reason, documentation pertaining to the highest levels of the system and to system control logic is included.

5.1 TOP LEVEL BUILD TREE

BUILD TREE FOR SERIAL NUMBER HPA 20W 4.2-18GHZ (AR) A28825-300

	A28825-300	HPA 20W 4.2-18GHZ (AR)
1A1	A23720-099	POWER SUPPLY(SHORT) FOR TWT 5172
1A1A1	A23711-000	MOTHER BOARD AND HEAT SINK
1A1A2	A23687-001	LOW VOLTAGE POWER SUPPLY MODULE
1A1A3	A16485-000	HPA LOGIC AND CONTROL MODULE
1A1A4	A23683-100	POWER FACTOR MODULE (500W)
1A1A4L4	A09006-000	PFC INDUCTOR FOR 100VAC-255VAC
1A1A5	A23710-000	POWER ASSEMBLY FOR 100WKU
1A1A5L1, L1A	A09007-000	INDUCTOR FOR BUCK REGULATOR
1A1A5T1 (E42)	A09402-000	XFMR,GATE DRIVE (HAND WOUND)
1A1A5T2 (E41)	A09403-000	XFMR,GATE DRIVE (HAND WOUND)
1A1A6	A21455-100	HIGH VOLTAGE DIODE/CAP ASSY FOR 100WKU
	A09484-000	HV XFMR FOR TWT 5181KU
1A1A7	A21457-001	HV FILTER MODULE
1A1A8	A10017-100	PWM BOARD (SPECIAL)
1A1A9	A10010-000	HEATER POWER SUPPLY MODULE
1A1A9T1	A09409-000	XFMR,HEATER FEEDBACK
1A1A9T2	A09408-000	XFMR,HEATER POWER
1A1A10	A24513-099	FACTORY SELECT PARTS
1A2	A28826-000	MICROWAVE POWER ASSEMBLY, AR 20CIJ
1A3	A25403-302	TWTA CONTROL ASSY 20 CIJ/50X
1A3A1	A25450-000	CPU BOARD W/POWERFAIL (20MHZ)
1A3A2	A25425-001	HPA DISPLAY BOARD
1A3A3	A22488-003	GPIB INTERFACE BOARD, 3U TWT PRODUCTS
1A4	A25444-000	HPA INTERFACE BOARD (PLASTIC FIBERS)
1A5	A24830-001	EMERGENCY BYPASS BOARD
1A9	A28827-000	CABINET ASSY AR 20CIJ, CPI TWT
1A11	A24830-002	EMERGENCY BYPASS BOARD
1A12	A25498-000	WIRING KIT 20W C/I/J

5.2 SCHEMATICS

10-16485-000	HPA Logic and Control (A16485-000)
10-25444-000	HPA Interface (A22444-000)
10-24830	Emergency Bypass Board (A24830-001)
10-24830-002	Emergency Bypass Board (A24830-002)
10-28825-300	HPA 20T Series (A28825-300)

5.3 WIRING DIAGRAMS

20-23720-099

TWT Power Supply AR 20T Series (A23720-099)

5.4 PARTS LISTS

A16485-000	HPA Logic and Control Assembly
A23720-099	Power Supply (Short) for TWT 5172
A24830-001	Emergency bypass board
A24830-002	Emergency bypass board
A25444-000	HPA Interface Board (Plastic)
A28825-300	HPA 20W 4.2-18GHZ (AR)
A28826-000	Microwave Power Assembly

5.4.1 Parts List, HPA Logic and Control Module, A16485-000

REF. DESIG.	ETM P/N	DESCRIPTION	QUANTITY
	B16485-000	HPA LOGIC AND CONTROL BOARD	1
C11	C16333-000	CAP,33MF,25V,AERL,(NICHICON UVX1E330M)	1
C2, C5, C15, C58	C31028-000	CAP,1000PF,200VDC,10%,CER,1% FAILURE,(KEMET CKR05 SERIES W/"V" OPTION)	4
C3, C9, C10, C13, C14, C17, C19, C21, C22, C27, C28, C30, C31, C33, C36, C46	C31032-000	CAP,0.01MF,200VDC,10%,CER,1% FAILURE,(KEMET CKR06 SERIES W/"V" OPTION)	16
C61	C31033-000	CAP,0.022MF,100VDC,10%,CER,1% FAILURE,(KEMET CKR06B223K W/V OPTION)	1
C24, C60	C31036-000	CAP,0.1MF,100VDC,10%,CER,1% FAILURE,(KEMET CKR06 SERIES W/"V" OPTION)	2
C1, C4, C6, C7, C16, C18, C25, C26, C32, C34, C37, C38, C39, C40, C41, C43, C44, C45, C48, C49	C31040-000	CAP,1MF,50VDC,10%,CER,1% FAILURE,(KEMET CKR06 SERIES W/"V" OPTION)	20
D16, D23, D31	D10965-000	ZENER,15V,(DIODES INC 1N965B)	3
D1, D3, D4, D5, D7, D8, D9, D10, D11, D12, D13, D17, D18, D19, D21, D22, D25, D26, D28, D30, D35, D37, D36	D14454-000	DIODE,AXIAL,(MOTOROLA 1N4454)	24
	D14733-000	ZENER,5.1V,1W,10%,AXIAL,(MOTOROLA 1N4733)	1
	F00010-000	WASHER,#2,LOCK,SST	3
	F10086-000	PHP,2-56 X 3/16SST	3
J2	J10370-000	CONN,37 PIN,MALE,D-SUB,PCB RIGHT ANGLE, (AMP 747252-4)	1
	J18075-000	MALE SCREW LOCK,FOR D SUBMIN CONN,(AMP 205817-1)	1
J4, J5	J18086-000	CONN,,SMA,JACK RECEPTACLE,RIGHT ANGLE,0-18GHZ,PC MOUNT [JOHNSON COMPONENTS 142-0701-301]	2
J1	N25003-000	HYPERTRONICS CONN,29 PIN MALE RIGHT ANGLE,(CUT ENDS)	1
Q2	Q22907-000	TRANSISTOR,PNP,2N2907A,TO-18	1
R1, R9, R19, R37, R44, R50	R00100-000	RES,10 OHM,1/4W,5%,CC,(A/B RC07GF100J)	6
R4, R20, R27, R29	R01100-000	RES,100 OHM,1/4W,5%,CC,(A/B RC07GF101J)	4
R5, R17, R18, R28, R34, R45, R49, R53, R54, R59, R71, R88	R02100-000	RES,1K,1/4W,5%,CC,(A/B RC07GF102J)	12
R6	R02270-000	RES,2.7K,1/4W,5%,CC,(A/B RC07GF272J)	1
R30, R31, R36	R02470-000	RES,4.7K,1/4W,5%,CC,(A/B RC07GF472J)	3
R86, R87	R02510-000	RES,5.1K,1/4W,5%,CC,(A/B RC07GF512J)	2
R75	R02560-000	RES,5.6K,1/4W,5%,CC,(A/B RC07GF562J)	1
R38, R77, R90	R03100-000	RES,10K,1/4W,5%,CC,(A/B RC07GF103J)	3
R32	R03470-000	RES,47K,1/4W,5%,CC,(A/B RC07GF473J)	1
R35	R05820-000	RES,8.2M,1/4W,5%,CC,(A/B RC07GF825J)	1
R13, R14	R10002-000	TRIMPOT,5K,1/2W,10%,CERMET,20T,SIDE ADJ,(BOURNS 3296X-1-502)	2
R76	R21499-000	RES,4.99K,1/2W,1%,MF,100PPM,(DALE RN55D)	1
R10	R21523-000	RES,5.23K,1/2W,1%,MF,100PPM,(DALE RN55D)	1
R16	R21866-000	RES,8.66K,1/2W,1%,MF,100PPM,(DALE RN55D)	1
R52, R73	R21887-000	RES,8.87K,1/2W,1%,MF,100PPM,(DALE RN55D)	2

REF. DESIG.	ETM P/N	DESCRIPTION	QUANTITY
R67	R21953-000	RES,9.53K,1/2W,1%,MF,100PPM,(DALE RN55D)	1
R47, R48	R22200-000	RES,20K,1/2W,1%,MF,100PPM,(DALE RN55D)	2
R79, R80	R22470-000	RES,47K,1/2W,1%,MF,100PPM,(DALE RN55D)	2
R42, R60, R61, R89	R23100-000	RES,100K,1/2W,1%,MF,100PPM,(DALE RN55D)	4
R33, R55	R23698-000	RES,698K,1/2W,1%,MF,100PPM,(DALE RN55D)	2
R41	R23750-000	RES,750K,1/2W,1%,MF,100PPM,(DALE RN55D)	1
R21	R23845-000	RES,845K,1/2W,1%,MF,100PPM,(DALE RN55D)	1
R66	R23953-000	RES,953K,1/2W,1%,MF,100PPM,(DALE RN55D)	1
R12, R15	R32020-000	TRIMPOT,10K,1/2W,10%,CERMET,20T,SIDE ADJ,(BECKMAN 67X)	2
U4, U5, U6	U02390-000	IC,QUAD COMPARATOR,(NAT LM139J)	3
U7	U03240-000	IC,LOW POWER OP AMP,(NAT LM324)	1
U9	U10070-000	REFERENCE,PRECISION 10V [LINEAR TECH LT1031DCH]	1
U8	U17805-000	IC,5V REGULATOR,TO-220,(NAT LM340T-5.0)	1
U1, U2, U3	U20148-000	IC,HEX INVERTER,SCHMIDTT TRIGGER,(74HC14) (SSD)	3
RP8	U30106-000	IC,10K,RES NETWORK,6 PIN,SIP (DALE MSP06A-01- 103G)	1
RP1-2, RP5-7, RP9	U30410-000	IC,10K,2%,0.40A,10 PIN,ISOLATED RESISTORS (DALE MSP10C-03-103G OR BOURNS 4610H-102- 103)	6
RP4	U31020-000	IC,1K RES NETWORK,SIP,(BECKMAN L061C102G)	1
W3-W8	W12200-000	WIRE, 22 AWG, BLU, 600V, TEFLON, (BELDEN 83006)	6

5.4.2 Parts List, Power Supply (Short) For TWT 5172, A23720-099

REF. DESIG.	ETM P/N	DESCRIPTION	QUANTITY
A9	A10010-000	HEATER POWER SUPPLY MODULE	1
A8	A10017-100	PWM BOARD (SPECIAL)	1
A3	A16485-000	HPA LOGIC AND CONTROL MODULE	1
A6	A21455-100	HIGH VOLTAGE DIODE/CAP ASSY FOR 100WKU	1
A7	A21457-001	HV FILTER MODULE	1
A4	A23683-100	POWER FACTOR MODULE (500W)	1
A2	A23687-001	LOW VOLTAGE POWER SUPPLY MODULE	1
A5	A23710-000	POWER ASSEMBLY FOR 100WKU	1
A1	A23711-000	MOTHER BOARD AND HEAT SINK	1
A10	A24513-099	FACTORY SELECT PARTS	1

5.4.3 Parts List, Emergency Bypass Board, A24830-001

REF. DESIG.	ETM P/N	DESCRIPTION	QUANTITY
	B24830-000	EMERGENCY BYPASS BOARD	1
C3-C5	C04105-000	CAP,0.1MF,100V,20%,MON,(KEMET C331C104M1R5CA)	3
C6	C30010-000	CAP,10MF,35V,TANT,RADIAL,(NEMCO TB10-35K1)	1
C2	C31028-000	CAP,1000PF,200VDC,10%,CER,1% FAILURE,(KEMET CKR05 SERIES W/"V" OPTION)	1
C1	C31032-000	CAP,0.01MF,200VDC,10%,CER,1% FAILURE,(KEMET CKR06 SERIES W/"V" OPTION)	1
C7	C31040-000	CAP,1MF,50VDC,10%,CER,1% FAILURE,(KEMET CKR06 SERIES W/"V" OPTION)	1
D1, D2	D14454-000	DIODE,AXIAL,(MOTOROLA 1N4454)	2
D3, D4	D14733-000	ZENER,5.1V,1W,10%,AXIAL,(MOTOROLA 1N4733)	2
I2, I3	I10066-000	LED,RED,HIGH EFFICIENCY,HIGH BRIGHTNESS	2
I1, I4	I10096-000	LED,GREEN,DIFFUSED,T1-3/4 (XC55G)	2
TP2	J16212-000	TEST JACK,RED,VERTICAL,(EF JOHNSON 105-0852-001)	1
TP3	J16213-000	TEST JACK,ORANGE,VERTICAL,(EF JOHNSON 105-0856-001)	1
J2	J18086-000	CONN.,SMA,JACK RECEPTACLE,RIGHT ANGLE,0-18GHZ,PC MOUNT [JOHNSON COMPONENTS 142-0701-301]	1
J1	J18180-000	CONN,D-SUB,15 PIN,MALE,STRAIGHT,PCB MOUNT (POSITRONIC MD15M3000)	1
Q1-Q3	Q22222-000	TRANSISTOR,NPN,2N2222A,TO-18	3
Q4, Q5	Q22907-000	TRANSISTOR,PNP,2N2907A,TO-18	2
R18, R23	R01100-000	RES,100 OHM,1/4W,5%,CC,(A/B RC07GF101J)	2
R21	R01150-000	RES,150 OHM,1/4W,5%,CC,(A/B RC07GF151J)	1
R19	R02100-000	RES,1K,1/4W,5%,CC,(A/B RC07GF102J)	1
R3, R5, R7	R02220-000	RES,2.2K,1/4W,5%,CC,(A/B RC07GF222J)	3
R22	R02330-000	RES,3.3K,1/4W,5%,CC,(A/B RC07GF332J)	1
R16, R17	R02470-000	RES,4.7K,1/4W,5%,CC,(A/B RC07GF472J)	2
R24	R02510-000	RES,5.1K,1/4W,5%,CC,(A/B RC07GF512J)	1
R4, R6, R8, R9, R13, R15	R03100-000	RES,10K,1/4W,5%,CC,(A/B RC07GF103J)	6
R1	R12107-000	TRIMPOT,1K,1/2W,10%,CERMET,1T,SIDE ADJ,(BECKMAN 72XL)	1
R20	R20267-000	RES,267 OHM,1/2W,1%,MF,100PPM,(DALE RN55D)	1
R10, R11, R12	R23100-000	RES,100K,1/2W,1%,MF,100PPM,(DALE RN55D)	3
R2	R30074-000	TRIMPOT,1K,1/2W,10%,CERMET,100PPM,20T,TOP ADJ,(BECKMAN 67W)	1
S2, S3	S22004-000	SWITCH,TOGGLE,DPDT,PC MNT,(AUGAT MTA-206N-PC)	2
S1	S22010-000	SWITCH,TOGGLE,4PDT,ON-NONE-ON,125V @ 6A,(AUGAT MTA-406N-PC)	1
U2	U11458-000	IC,DUAL OP AMP,(NAT LM1458CN)	1
U1	U17805-000	IC,5V REGULATOR,TO-220,(NAT LM340T-5.0)	1

5.4.4 Parts List, Emergency Bypass Board, A24830-002

REF. DESIG.	ETM P/N	DESCRIPTION	QUANTITY
	B24830-000	EMERGENCY BYPASS BOARD	1
C3-C5	C04105-000	CAP,0.1MF,100V,20%,MON,(KEMET C331C104M1R5CA)	3
C6	C30010-000	CAP,10MF,35V,TANT,RADIAL,(NEMCO TB10-35K1)	1
C1, C2	C31032-000	CAP,0.01MF,200VDC,10%,CER,1% FAILURE,(KEMET CKR06 SERIES W/"V" OPTION)	2
C7	C31040-000	CAP,1MF,50VDC,10%,CER,1% FAILURE,(KEMET CKR06 SERIES W/"V" OPTION)	1
D1, D2	D14454-000	DIODE,AXIAL,(MOTOROLA 1N4454)	2
D3, D4	D14733-000	ZENER,5.1V,1W,10%,AXIAL,(MOTOROLA 1N4733)	2
I4	I10096-000	LED,GREEN,DIFFUSED,T1-3/4 (XC55G)	1
TP2	J16212-000	TEST JACK,RED,VERTICAL,(EF JOHNSON 105-0852-001)	1
TP3	J16213-000	TEST JACK,ORANGE,VERTICAL,(EF JOHNSON 105-0856-001)	1
J2	J18086-000	CONN.,SMA,JACK RECEPTACLE,RIGHT ANGLE,0-18GHZ,PC MOUNT [JOHNSON COMPONENTS 142-0701-301]	1
J1	J31055-000	CONN,D-SUB,15 PIN,FEMALE,STRAIGHT,PCB MOUNT,[AMPHENOL 17D-A15S-U]	1
Q4, Q5	Q22907-000	TRANSISTOR,PNP,2N2907A,TO-18	2
R18, R23	R01100-000	RES,100 OHM,1/4W,5%,CC,(A/B RC07GF101J)	2
R21	R01514-000	RES,510 OHM,1W,5%,CC,(A/B, RC20GF511J)	1
R19	R02100-000	RES,1K,1/4W,5%,CC,(A/B RC07GF102J)	1
R22	R02330-000	RES,3.3K,1/4W,5%,CC,(A/B RC07GF332J)	1
R16, R17	R02470-000	RES,4.7K,1/4W,5%,CC,(A/B RC07GF472J)	2
R9, R13, R15	R03100-000	RES,10K,1/4W,5%,CC,(A/B RC07GF103J)	3
R20	R20267-000	RES,267 OHM,1/2W,1%,MF,100PPM,(DALE RN55D)	1
R10, R11, R12	R23100-000	RES,100K,1/2W,1%,MF,100PPM,(DALE RN55D)	3
R2	R30074-000	TRIMPOT,1K,1/2W,10%,CERMET,100PPM,20T,TOP ADJ,(BECKMAN 67W)	1
U2	U11458-000	IC,DUAL OP AMP,(NAT LM1458CN)	1
U1	U17808-000	IC,8V REGULATOR,TO-220,(NAT LM340T-8.0 OR LM7808)	1

5.4.5 Parts List, HPA Interface Board (Plastic), A25444-000

REF. DESIG.	ETM P/N	DESCRIPTION	QUANTITY
	B25444-000	HPA INTERFACE BOARD	1
C161	C03105-000	CAP,0.01MF,100V,CER,10%,RADIAL,(AVX SR201C103KAA)	1
C171	C04223-000	CAP,0.22MF,35V,TANT,RADIAL,[JAMCO 33507]	1
C20, C32, C100	C05153-000	CAP,1.5MF,35V,TANT,RADIAL,(AVAX, TAP155K035SCS)	4
C129, C163	C05223-000	CAP,2.2MF,35V,10%,SOLID SEALED TANT,RADIAL,(SPRAGUE 199D225X9035BA1)	2
C80, C81, C164	C06103-000	CAP,10MF,25V,20%,SOLID TANT,RADIAL,(AVX TAP106M025HSB)	3
C15	C06220-000	CAP,22MF,16V,SOLID TANT,RADIAL,(AVX TAP226K016SCS)	1
C99	C16103-000	CAP,10MF,35V,AERL,(NICHICON UVR1V100MDA)	1
C101	C17222-000	CAP,220MF,16V,AERL,(NICHICON, UVR1C221MEA)	1
C47, C67	C17224-000	CAP,220MF,50V,AERL,(ILL CAP 227RAR050A)	2
C44, C168, C169	C30066-000	CAP 47 MF, 35V, SOLID TANT. RADIAL, (KEMET T356M476K035AS)	3
C165, C166, C6, C7, C9, C13, C16, C39,	C31016-000	CAP,100PF,200VDC,10%,CER,1% FAILURE,(KEMET CKR05 SERIES W/"V" OPTION)	10
107, 108, 109, 110, 111, 112, 113, 114, 115, 116, 117, 121, 125, 132, 167, 1, 2, 3, 4, 5, 10, 11, 22, 23, 24, 25, 26, 28, 30, 33, 35, 40, 41, 42, 48, 49, 50, 51, 53, 62, 63, 64, 65, 70, 71, 73, 77, 79, 83, 85, 87, 88, 89, 91, 94, 96, 97, 98, 102,	C31036-000	CAP,0.1MF,100VDC,10%,CER,1% FAILURE,(KEMET CKR06 SERIES W/"V" OPTION)	61
C12, C14, C21, C27, C29, C31, C34, C36, C38, C17, C18, C19, C37, C54, C55, C56, C57, C58, C59, C60, C61, C118, C119, C120, C122, C123, C124, C133, C46, C52, C66, C68, C72, C75, C82, C84, C86, C90, C92, C93, C95, C104, C106,	C31040-000	CAP,1MF,50VDC,10%,CER,1% FAILURE,(KEMET CKR06 SERIES W/"V" OPTION)	44
D8, D10-D16, D18-D19	D14007-000	DIODE,1000V,1A,AXIAL,(MOTOROLA 1N4007)	10
D1-D7	D14454-000	DIODE,AXIAL,(MOTOROLA 1N4454)	7
D9, D17	D14733-000	ZENER,5.1V,1W,10%,AXIAL,(MOTOROLA 1N4733)	2
I1	I10074-000	LED,GREEN,ALGAAS,NON-DIFFUSED,(HEWLETT PACKARD HLMP-1540)	1
J5	J10021-000	HEADER,2 PIN,MALE,RIGHT ANGLE,SERIES 7478 (MOLEX 22-05-3021)	1
J1	J10371-000	D-SUB,37 PIN MALE,PCB MOUNT,STRAIGHT (POSITRONICS MD37M3S000)	1
XU17	J14161-000	SKT,DIP,16 PIN,MACH SLEEVES,(AUGAT 516-AG11D)	1
XU26	J14202-000	SKT,DIP,20 PIN,MACH SLEEVES,(SAMTEC ICA-320-SGT)	1
XU15	J14281-000	SKT,DIP,28 PIN,MACH SLEEVES,(SAMTEC ICA-628-SGT)	1
TP0	J16210-000	TEST JACK,BLACK,VERTICAL,(EF JOHNSON 105-0853-001)	1
TP1	J16211-000	TEST JACK,BROWN,VERTICAL,(EF JOHNSON 105-0858-001)	1
TP2	J16212-000	TEST JACK,RED,VERTICAL,(EF JOHNSON 105-0852-001)	1
TP3	J16213-000	TEST JACK,ORANGE,VERTICAL,(EF JOHNSON 105-0856-001)	1

Model 20T4G18

REF. DESIG.	ETM P/N	DESCRIPTION	QUANTITY
TP4	J16214-000	TEST JACK,YELLOW,VERTICAL,(EF JOHNSON 105-0857-001)	1
TP5	J16215-000	TEST JACK,GREEN,VERTICAL,(EF JOHNSON 105-0854-001)	1
TP6	J16216-000	TEST JACK,BLUE,VERTICAL,(EF JOHNSON 105-0860-001)	1
J4	J18167-000	D-SUB,37 PIN,FEMALE,PCB MOUNT,RIGHT ANGLE (AMP 745784-4)	1
J3	J18180-000	CONN,D-SUB,15 PIN,MALE,STRAIGHT,PCB MOUNT (POSITRONIC MD15M3000)	1
J2	J31013-000	CONN,D-SUB,25 PIN,MALE,RIGHT ANGLE,PCB MOUNT,[AMP 747238-4]	1
XJ1-XJ4	J31014-000	SPRING LATCH KIT,D-SUB,(AMPHENOL 17-529)	4
K1-K6	K02009-000	RELAY,DPDT,5VDC,125V @ 0.5A / 30VDC @ 1A CONTACTS,PCB TERMINALS,SEALED (OMRON G6H-2-DC5)	6
L1-L4	L00200-000	WIDE BAND CHOKE,(VK200 10/3B FERROXCUBE)	4
Q1, Q2, Q3, Q4, Q5, Q6, Q7, Q8	Q22222-000	TRANSISTOR,NPN,2N2222A,TO-18	8
R2	R01220-000	RES,220 OHM,1/4W,5%,CC,(A/B RC07GF221J)	1
R41	R01680-000	RES,680 OHM,1/4W,5%,CC,(A/B RC07GF681J)	1
R1	R04200-000	RES,200K,1/4W,5%,CC,(A/B RC07GF204J)	1
R4, R7	R05820-000	RES,8.2M,1/4W,5%,CC,(A/B RC07GF825J)	2
R6, R8, R58	R20100-000	RES,100 OHM,1/2W,1%,MF,100PPM,(DALE RN55D)	3
R57	R20200-000	RES,200 OHM,1/2W,1%,MF,100PPM,(DALE RN55D)	1
R11	R20243-000	RES,243 OHM,1/2W,1%,MF,100PPM,(DALE RN55D)	1
R16	R20845-000	RES,845 OHM,1/2W,1%,MF,100PPM,(DALE RN55D)	1
R59	R22332-000	RES,33.2K,1/2W,1%,MF,100PPM,(DALE RN55D)	1
R3, R5	R30071-000	TRIMPOT,10K,1/2W,10%,CERMET,100PPM,20T, TOP ADJ,(BECKMAN 67W)	2
R9, R12, R15, R22, R35, R36, R40, R44,	R30103-000	RES,10K,1/8W,1%,MF,AXIAL,100PPM,(DALE CMF-50 / RN50C1002F)	9
R17, R19, R20, R21, R23, R25, R28, R31, R42, R43, R46, R18	R30140-000	RES,1K,1/8W,1%,MF,50PPM,(DALE RN50C)	12
R13, R14, R24, R26, R27, R29, R32, R37, R38, R39, R47	R31164-000	RES,100K,1/20W,1%,FILM,AXIAL,100PPM,MIL,(DALE RN50C1003F)	11
U7, U8	U00027-000	IC,ULTRA LOW NOISE PRECISION OP AMP,(ANALOG DEVICES OP27GP)	2
U26	U00029-000	CONVERTER,NO OIL,16BIT,A TO D,SERIAL OUT,[BURR-BROWN ADS7809PB,PB],[ANALOG DEVICES AD977CN]	1
U17	U00524-000	IC,INSTRUMENTATION AMP,(ANALOG DEVICES AD524A) (SSD)	1
U15	U00725-000	IC,DUAL 16 BIT DIGITAL TO ANALOG CONVERTER,(BURR-BROWN DAC-725) (SSD)	1
U1	U03171-000	IC,ADJUSTABLE VOLTAGE REGULATOR,15W,1.5A, TO-220,(NAT LM317T)	1
U9, U10, U18	U04090-000	IC,4CH ANALOG MULTIPLEXER,(DATEL MXD-409)	3
DP2, DP4, DP5, DP8, DP9	U08010-000	IC,8 COMMON CATHODE CLAMPING DIODES,9 PIN SIP,(ROHM DAN801)	5
DP1, DP3, DP6, DP7, DP10	U08011-000	IC,8 COMMON ANODE CLAMPING DIODES,9PIN SIP,(ROHM DAP801)	5
U27	U11165-000	IC,6.5536MHZ CLOCK OSCILLATOR,1/2 SIZE,(ECLIPTEK EC1100HS-6.5536MHZ) (SSD)	1
U40	U11528-000	IC,VERSALINK TRANSMITTER,HORIZONTAL,(200UM FIBER) (HEWLETT PACKARD HFBR-1528)	1
U54	U12521-000	IC,FIBER OPTIC RECEIVER,HORIZONTAL,(HP HFBR-2521) (SSD)	1
U36	U17545-000	DRIVER,OIL,DS75451N,DUAL AND,[NATIONAL SEMICONDUCTOR DS75451N]	1

REF. DESIG.	ETM P/N	DESCRIPTION	QUANTITY
U6, U19, U34, U39, U60	U20148-000	IC,HEX INVERTER,SCHMIDTT TRIGGER,(74HC14) (SSD)	5
U42	U20730-000	IC,DUAL J-K FLIP FLOP W/RESET,(7473) (SSD)	1
U51	U21328-000	IC,QUAD 2 INPUT NAND,SCHMIDTT TRIGGER,(74HC132) (SSD)	1
U52	U21388-000	IC,3 TO 8 DECODER/DEMULTIPLEXER,INVERTING,(74HC138) (SSD)	1
U32	U21536-000	IC,DUAL 4 INPUT DIGTAL MULTIPLEXER,(74F153) (SSD)	1
U35	U22598-000	IC,8 BIT ADDRESSABLE LATCH W/RESET,(74HC259) (SSD)	1
U47	U23909-000	IC,DUAL 4 BIT BINARY/BIQUINARY COUNTER (74HCT390) (SSD)	1
U41, U48	U24018-000	IC,JOHNSON DECADE COUNTER W/10 DECODED OUTPUTS,(74HC4017) (SSD)	2
U45	U24138-000	IC,8 BIT BINARY DOWN COUNTER,(74HC40103) (SSD)	1
U43	U26889-000	IC,8 BIT MAGNITUDE COMPARATOR,(74HCT688) (SSD)	1
U22, U24, U57	U28008-000	IC,QUAD 2 INPUT AND,(74HC08) (SSD)	3
U4, U49, U58	U28032-000	IC,QUAD 2 INPUT OR,(74HC32) (SSD)	3
U44, U46	U28040-000	IC,12 BIT DECADE COUNTER,(74HCT4040) (SSD)	2
U5, U13, U14, U23, U25, U33, U50	U28074-000	IC,DUAL D FLIP FLOP W/RESET,(74HC74) (SSD)	7
U2	U28123-000	IC,DUAL RETRIGGERABLE 1-SHOT,(74HC123) (SSD)	1
U31, U53	U28164-000	IC,8 BIT SERIAL IN PARALLEL OUT SHIFT REGISTER,(74HC164) (SSD)	2
U3, U12, U28, U37, U38	U28165-000	IC,8 BIT PARALLEL IN SERIAL OUT SHIFT REGISTER,(74HC165) (SSD)	5
RP6	U32001-000	IC,1K FEED-THROUGH RES NETWORK,16 PIN DIP,(A/B 316B102)	1
RP1-RP5	U32103-000	IC,10K FEED-THROUGH RES NETWORK,16 PIN DIP,(A/B 316B103)	5
U56	U40008-000	REGULATOR,OIL,5V,100MA,TO-92,[MOTOROLA MC78L05ABP]	1
U55	U40012-000	FLIP-FLOP,OCTAL D-TYPE LATCH WITH RESET,[NATIONAL MM74HC273N]	1

5.4.6 Parts List, HPA 20W 4.2-18GHZ (AR), A28825-300

REF. DESIG.	ETM P/N	DESCRIPTION	QUANTITY
A1	A23720-099	POWER SUPPLY(SHORT) FOR TWT 5172	1
A5	A24830-001	EMERGENCY BYPASS BOARD	1
A11	A24830-002	EMERGENCY BYPASS BOARD	1
A3	A25403-302	TWTA CONTROL ASSY 20 CIJ/50X	1
A4	A25444-000	HPA INTERFACE BOARD (PLASTIC FIBERS)	1
A12	A25498-000	WIRING KIT 20W C//J	1
A2	A28826-000	MICROWAVE POWER ASSEMBLY, AR 20CIJ	1
A9	A28827-000	CABINET ASSY AR 20CIJ, CPI TWT	1

5.4.7 Parts List, Microwave Power Assembly, AR, A28826-000

REF. DESIG.	ETM P/N	DESCRIPTION	QUANTITY
W3	E00888-007	CABLE,RF FLEX, 7,SMA,MALE TO MALE,20 GHZ,50 OHM,BLUE FEP TEFLON (DICAR EZ402-2121-07)	1
W6	E00888-009	CABLE,RF FLEX, 9,SMA,MALE TO MALE,20 GHZ,50 OHM,0.141 CABLE,INSULATED JACKET,[SRC 150-150-150090]	1
W5	E00888-012	CABLE,RF FLEX,12,SMA,MALE TO MALE,20 GHZ,50 OHM,0.141 CABLE,INSULATED JACKET,[SRC 150-150-150120]	1
W2	E00888-015	CABLE,RF FLEX,15,SMA,MALE TO MALE,20 GHZ,50 OHM,0.141 CABLE, INSULATED JACKET, [SRC 150-150-150150]	1
W1	E00888-020	CABLE,RF FLEX,20,SMA,MALE TO MALE,20 GHZ,50 OHM,0.141 CABLE, INSULATED JACKET,[SRC 150-150-150200]	1
A1	E01122-000	SSPA, 4-18 GHZ, +18DBM, 20DB GAIN, WITH 35DB VGA, [CPI CMA40180A(XX)]	1
A2	E08137-000	TWT, 4-18 GHZ, 25 WATTS,[CPI VTM-6196R5]	1
R1	E20012-000	ATTENUATOR 6DB SMA 2W,SUB-MINIATURE,[INMET, 18A-6]	1
R2	E20064-000	ATTENUATOR,3DB,2W,DC-18GHZ,MINITURE,(MIDISCO, MDC1065R-3]	1
A4	E20129-000	COUPLER,10DB,4-18GHZ,SMA,(MAC TECHNOLOGIES C4258-10)	1
	E20130-000	ADAPTER,SMA MALE TO SMA FEMALE,RIGHT ANGLE (CDI 5490CCSF / PASTERNAK PE9262)	4
A5	E20279-000	EQUALIZER,4-18 GHZ,0-20 DB @ 11 GHZ,SMA,(INMET EQ1734)	1
D1, D2	E20284-000	ZERO-BIAS SCHOTTKY DETECTOR,10MHZ-18.5GHZ,POSITIVE OUT PUT POLARITY,(RLC, M-3747)	2
W4	E20476-000	RF CABLE, 18" LONG, 0.290 DIA, TNC-SP TO SMA-RAP [STORM 90-1343-018]	1
A3	E24814-000	DUAL COUPLER,4.2-18GHZ,PTNC,-35DB/-35DB,(MAC TECHNOLOGY CA1158-35B)	1
J1, J2	J17264-000	ADAPTER,TYPE N FEMALE TO SMA FEMALE,PANEL MOUNT,(ASTROLAB 29047)	2
	J18160-000	CONN,1 PIN,FEMALE,20KV,10A,0.180 DIA. LEAD,[CONNECTRONICS 11039-02]	4

5.5 RECOMMENDED SPARE PARTS

A16491-000	Auxiliary power supply module (low voltage power supply).
A21455-100	High voltage diode/cap assembly
A21454-000	High voltage filter assembly
A10010-000	Heater power supply module
Y10057-000	Spinnaker DC blower (Comair Rotron model SPD24B1, part no. 032183)

5.6 SAMPLE PROGRAM FOR IEEE-488 COMMUNICATION

```
1000 ! *****
1010 ! *      IEEE-488 COMMUNICATIONS SOFTWARE      *
1030 ! *      7/24/92  AARON D. McCLURE          *
1040 ! *****
1041 DIM F$(80)
1042 DIM A$(80)
1050 CLEAR SCREEN
1060 INPUT "INPUT COMMAND TO SEND TO POWER SUPPLY.  EXIT TO QUIT.",A$
1070 IF A$="EXIT" THEN 1130
1080 OUTPUT 701;A$
1090 IF A$[1,2]<>"RD" THEN GOTO 1060
1095 IF A$[1,1]="*" THEN GOTO 1100
1100 ENTER 701;F$
1110 PRINT "OUTPUT FROM COMMAND ",A$," IS ",F$
1120 GOTO 1060
1130 CLEAR SCREEN
1140 END
```

WARRANTIES: LIMITATION OF LIABILITY

Seller warrants (i) that seller has title to the goods sold and (ii) that Amplifiers, Antennas, Pre-compliance Test Systems, Transient Generators, Power Meters, Directional Couplers and Tripods will be free from defects in material and workmanship for a period of three (3) years from date of shipment shown on Amplifier Research invoice. Field Monitoring Equipment, Teseo Fiberoptic Systems and Traveling Wave Tubes in the 200T1G3A, 200T2G8A and 200T8G18A will be free from defects in material and workmanship for a period of two (2) years from date of shipment. Vacuum tubes, traveling-wave tubes in models not previously listed and power heads will be free from defects in material and workmanship for a period of one (1) year. Contact Amplifier Research for warranty information regarding items not listed. Seller's sole responsibility in fulfilling these warranties shall be to repair or replace any goods which do not conform to the foregoing warranties or, at seller's option, to give buyer credit for defective goods. The warranty is valid only when used in the country specified at time of order. Warranty service must be obtained from the repair facility designated at that time. If warranty service is not available in the country where the equipment is to be used, it must be returned to Amplifier Research. Warranty service will be provided only for defective goods which are returned within the warranty period, freight costs prepaid to Amplifier Research or its designated repair facility.

There are no other warranties, express or implied, including any warranty of merchantability or fitness. Seller shall not be responsible for any incidental or consequential damages arising from any breach of warranty.

No person other than an officer of Amplifier Research Corporation, has any authority to bind seller to any affirmation, representation or warranty except as specifically included in the preceding terms and conditions.

