

HD68P01V07, HD68P01V07-1- HD68P01M0, HD68P01M0-1 MCU (Microcomputer Unit)

The HD68P01 is an 8-bit single chip microcomputer unit (MCU) which significantly enhances the capabilities of the HMCS6800 family of parts. It can be used in production systems to allow for easy firmware changes with minimum delay or it can be used to emulate the HD6801 for software development. It includes 128 bytes of RAM, Serial Communications Interface (SCI), parallel I/O and a three function Programmable Timer on chip, and 2048 bytes, 4096 bytes or 8192 bytes of EPROM on package. It includes an upgrade HD6800 microprocessing unit (MPU) while retaining upward source and object code compatibility. Execution times of key instructions have been improved and several new instructions have been added including an unsigned 8 by 8 multiply with 16-bit result. The HD68P01 can function as a monolithic microcomputer or can be expanded to a 65k byte address space. It is TTL compatible and requires one +5 volt power supply. A summary of HD68P01 features includes:

■ FEATURES

- Expanded HMCS6800 Instruction Set
- 8 x 8 Multiply Instruction
- Serial Communications Interface (SCI)
- Upward Source and Object Code Compatible with HD6800
- 16-bit Three-function Programmable Timer
- Applicable to All Type of EPROM
 - 4096 bytes; HN482732A
 - 8192 bytes; HN482764
- 128 Bytes of RAM (64 bytes Retainable on Powerdown)
- 29 Parallel I/O and Two Handshake Control Line
- Internal Clock Generator with Divide-by-Four Output
- Full TTL Compatibility
- Full Interrupt Capability
- Single-Chip or Expandable to 65k Bytes Address Space
- Bus compatible with HMCS6800 Family

■ TYPE OF PRODUCTS

Type No.	Bus Timing	EPROM Type No.
HD68P01V07	1 MHz	HN482732A-30
HD68P01V07-1	1.25MHz	HN482732A-30
HD68P01M0	1 MHz	HN482764-3
HD68P01M0-1	1.25MHz	HN482764-3

Note) EPROM is not attached to the MCU.

■ PROGRAM DEVELOPMENT SUPPORT TOOLS

- Cross assembler software for use with IBM PCs and compatibles
- In circuit emulator for use with IBM PCs and compatibles

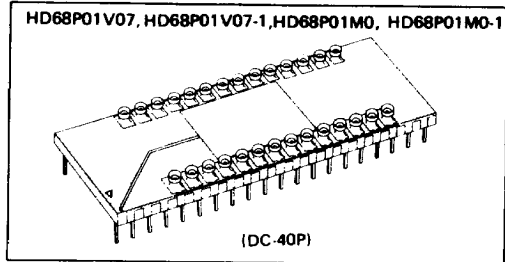

■ PIN ARRANGEMENT (Top View)

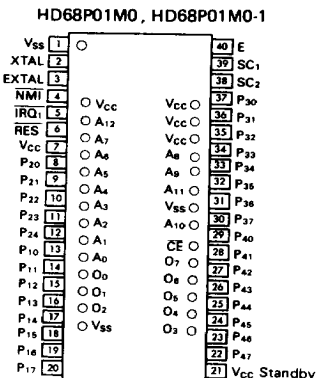
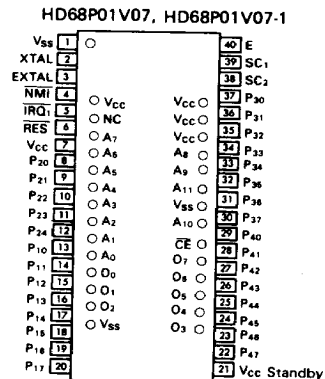

■ BLOCK DIAGRAM

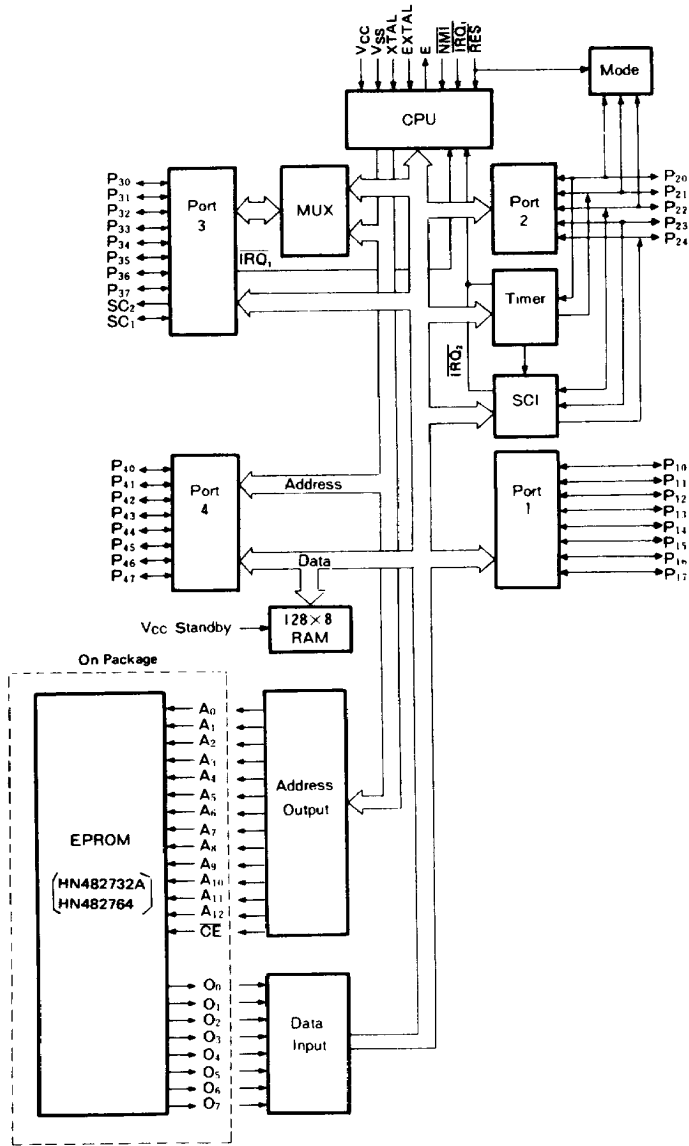

■ ABSOLUTE MAXIMUM RATINGS

Item	Symbol	Value	Unit
Supply Voltage	V_{CC}^*	-0.3 ~ +7.0	V
Input Voltage	V_{in}^*	-0.3 ~ +7.0	V
Operating Temperature	T_{opr}	0 ~ +70	°C
Storage Temperature	T_{stg}	-55 ~ +150	°C

* With respect to V_{SS} (SYSTEM GND)

[NOTE] Permanent LSI damage may occur if maximum ratings are exceeded. Normal operation should be under recommended operating conditions. If these conditions are exceeded, it could affect reliability of LSI.

■ ELECTRICAL CHARACTERISTICS

● DC CHARACTERISTICS ($V_{CC} = 5.0V \pm 5\%$, $V_{SS} = 0V$, $T_a = 0 \sim +70^\circ C$; unless otherwise noted.)

Item	Symbol	Test Condition	min	typ	max	Unit			
Input "High" Voltage	RES	V_{IH}	4.0	—	V_{CC}	V			
	Other Inputs*		2.0	—	V_{CC}				
Input "Low" Voltage	All Inputs*	V_{IL}	-0.3	—	0.8	V			
Input Load Current	$P_{40} \sim P_{47}$	$ I_{in} $	$V_{in} = 0 \sim 2.4V$	—	—	0.5	mA		
	SC_1			—	—	0.8			
	EXTAL			—	—	1.2			
Input Leakage Current	NMI, IRQ_1 , RES	$ I_{in} $	$V_{in} = 0 \sim 5.25V$	—	—	2.5	μA		
Three State (Offset) Leakage Current	$P_{10} \sim P_{17}$, $P_{30} \sim P_{37}$ $P_{20} \sim P_{24}$	$ I_{TSI} $	$V_{in} = 0.5 \sim 2.4V$	—	—	10	μA		
Output "High" Voltage	$P_{30} \sim P_{37}$	V_{OH}	$I_{LOAD} = -205 \mu A$	2.4	—	—	V		
	$P_{40} \sim P_{47}$, E, SC_1 , SC_2			Other Outputs	$I_{LOAD} = -145 \mu A$	2.4		—	—
					$I_{LOAD} = -100 \mu A$	2.4		—	—
Output "Low" Voltage	All Outputs	V_{OL}	$I_{LOAD} = 1.6 mA$	—	—	0.5	V		
Darlington Drive Current	$P_{10} \sim P_{17}$	$-I_{OH}$	$V_{out} = 1.5V$	1.0	—	10.0	mA		
Power Dissipation		P_D		—	—	1200	mW		
Input Capacitance	$P_{30} \sim P_{37}$, $P_{40} \sim P_{47}$, SC_1	C_{in}	$V_{in} = 0V$, $T_a = 25^\circ C$, $f = 1.0 MHz$	—	—	12.5	pF		
	Other Inputs			—	—	12.5			
V_{CC} Standby	Powerdown	V_{SBB}		4.0	—	5.25	V		
	Operating	V_{SB}		4.75	—	5.25			
Standby Current	Powerdown	I_{SBB}	$V_{SBB} = 4.0V$	—	—	8.0	mA		

*Except Mode Programming Levels: See Figure 8.



HD68P01V07, HD68P01V07-1, HD68P01M0, HD68P01M0-1

● AC CHARACTERISTICS

BUS TIMING ($V_{CC} = 5.0V \pm 5\%$, $V_{SS} = 0V$, $T_a = 0 \sim +70^\circ C$, unless otherwise noted.)

Item	Symbol	Test Condition	HD68P01V07/M0			HD68P01V07-1/M0-1			Unit
			min	typ	max	min	typ	max	
Cycle Time	t_{cyc}		1	—	10	0.8	—	10	μs
Address Strobe Pulse width "High"	PW _{ASH}		200	—	—	150	—	—	ns
Address Strobe Rise Time	t_{ASr}		5	—	50	5	—	50	ns
Address Strobe Fall Time	t_{ASf}		5	—	50	5	—	50	ns
Address Strobe Delay Time*	t_{ASD}		60	—	—	30	—	—	ns
Enable Rise Time	t_{Er}		5	—	50	5	—	50	ns
Enable Fall Time	t_{Ef}		5	—	50	5	—	50	ns
Enable Pulse Width "High" Time*	PW _{EH}		450	—	—	340	—	—	ns
Enable Pulse Width "Low" Time*	PW _{EL}		450	—	—	350	—	—	ns
Address Strobe to Enable Delay Time*	t_{ASED}		60	—	—	30	—	—	ns
Address Delay Time	t_{AD}	Fig. 1	—	—	260	—	—	260	ns
Address Delay Time for Latch (f = 1.0MHz)*	t_{ADL}	Fig. 2	—	—	270	—	—	260	ns
Data Set-up Write Time	t_{DSW}		225	—	—	115	—	—	ns
Data Set-up Read Time	t_{DSR}		80	—	—	70	—	—	ns
Data Hold Time	Read	t_{HR}	10	—	—	10	—	—	ns
	Write	t_{HW}	20	—	—	20	—	—	
Address Set-up Time for Latch*	t_{ASL}		60	—	—	50	—	—	ns
Address Hold Time for Latch	t_{AHL}		20	—	—	20	—	—	ns
Address Hold Time	t_{AH}		20	—	—	20	—	—	ns
Peripheral Read Access Time	Non-Multiplexed Bus*	(t_{ACCN})	—	—	(610)	—	—	(420)	ns
	Multiplexed Bus*	(t_{ACCM})	—	—	(600)	—	—	(420)	
Oscillator stabilization Time	t_{RC}	Fig. 11	100	—	—	100	—	—	ms
Processor Control Set-up Time	t_{PCS}	Fig. 12	200	—	—	200	—	—	ns

* These timings change in approximate proportion to t_{cyc} . The figures in this characteristics represent those when t_{cyc} is minimum (= in the highest speed operation).

PERIPHERAL PORT TIMING ($V_{CC} = 5.0V \pm 5\%$, $V_{SS} = 0V$, $T_a = 0 \sim +70^\circ C$, unless otherwise noted.)

Item	Symbol	Test Condition	min	typ	max	Unit
Peripheral Data Setup Time	Port 1, 2, 3, 4	t_{PDSU}	200	—	—	ns
Peripheral Data Hold Time	Port 1, 2, 3, 4	t_{PDH}	200	—	—	ns
Delay Time, Enable Positive Transition to $\overline{OS3}$ Negative Transition		t_{OSD1}	—	—	350	ns
Delay Time, Enable Positive Transition to $\overline{OS3}$ Positive Transition		t_{OSD2}	—	—	350	ns
Delay Time, Enable Negative Transition to Peripheral Data Valid	Port 1, 2*, 3, 4	t_{PWD}	—	—	400	ns
Delay Time, Enable Negative Transition to Peripheral CMOS Data Valid	Port 2*, 4	t_{CMOS}	—	—	2.0	μs
Input Strobe Pulse Width		t_{PWiS}	200	—	—	ns
Input Data Hold Time	port 3	t_{IH}	50	—	—	ns
Input Data Set-up Time	Port 3	t_{IS}	20	—	—	ns

*Except P₂₁ ** 10k Ω pull up register required for Port 2



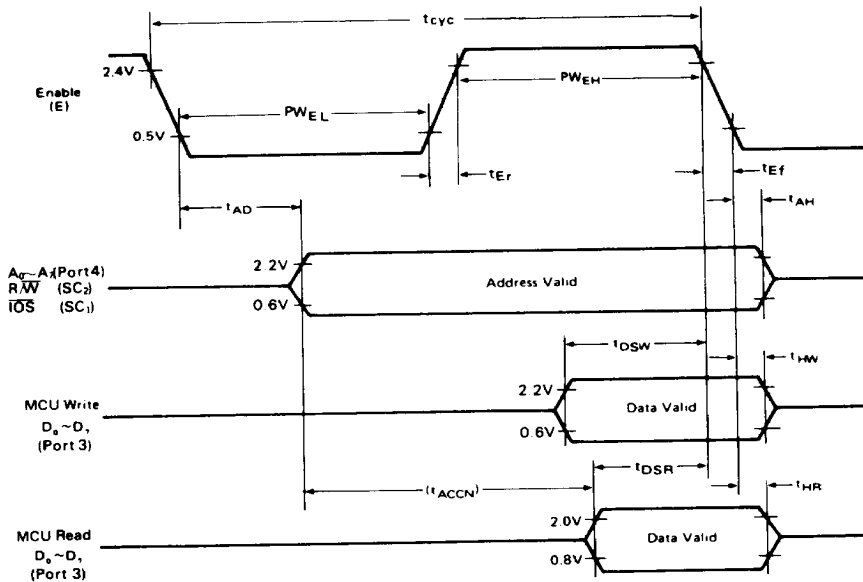
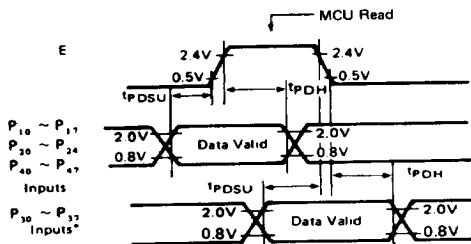
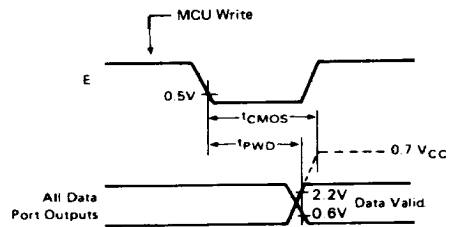

Figure 2 Expanded Non-Multiplexed Bus Timing



*Port 3 Non-Latched Operation (LATCH ENABLE = 0)

Figure 3 Data Set-up and Hold Times (MCU Read)



- (NOTE) 1. 10 kΩ Pullup resistor required for Port 2 to reach 0.7 V_{CC}
 2. Not applicable to P₃₁
 3. Port 4 cannot be pulled above V_{CC}

Figure 4 Port Data Delay Timing (MCU Write)

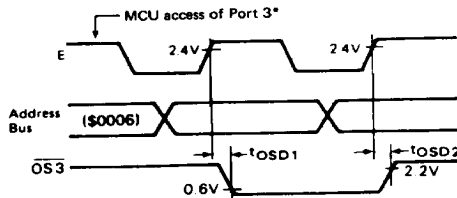

*Access matches Output Strobe Select (OSS = 0, a read; OSS = 1, a write)

Figure 5 Port 3 Output Strobe Timing (Single Chip Mode)

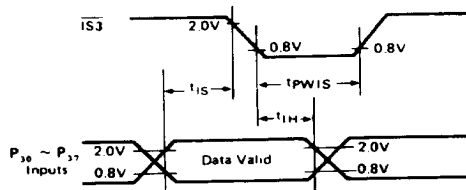

Figure 6 Port 3 Latch Timing (Single Chip Mode)



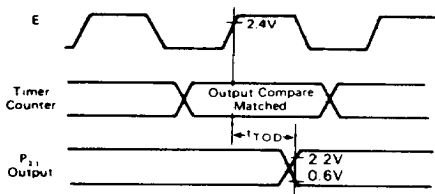

Figure 7 Timer Output Timing

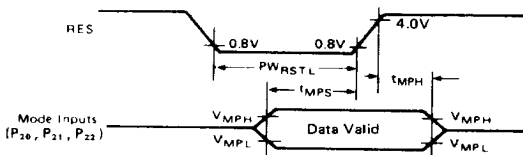

Figure 8 Mode Programming Timing

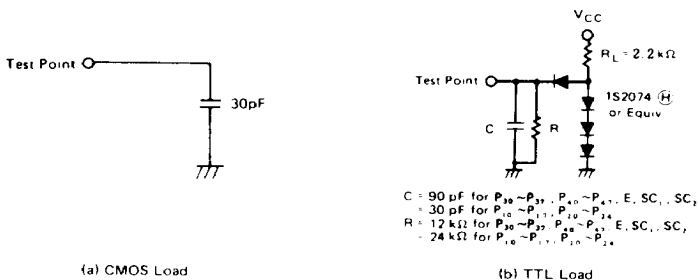

Figure 9 Bus Timing Test Loads

INTRODUCTION

The HD68P01 is an 8-bit monolithic microcomputer which can be configured to function in a wide variety of applications. The facility which provides this extraordinary flexibility is its ability to be hardware programmed into eight different operating modes. The operating mode controls the configuration of 18 of the MCU's 40 pins, available on-chip resources, memory map, location (internal or external) of interrupt vectors, and type of external bus. The configuration of the remaining 22 pins is not dependent on the operating mode.

Twenty-nine pins are organized as three 8-bit ports and one 5-bit port. Each port consists of at least a Data Register and a write-only Data Direction Register. The Data Direction Register is used to define whether corresponding bits in the Data Register are configured as an input (clear) or output (set).

The term "port", by itself, refers to all of its associated hardware. When the port is used as a "data port" or "I/O port", it is controlled by its Data Direction Register and the programmer has direct access to its pins using the port's Data Register. Port pins are labeled as Pij where i identifies one of four ports and j indicates the particular bit.

The Microprocessor Unit (MPU) is an enhanced HD6800 MPU with additional capabilities and greater throughput. It is upward source and object code compatible with the HD6800. The programming model is depicted in Figure 10 where Accumulator D is a concatenation of Accumulators A and B. A list of new operations added to the HMCS6800 instruction set are shown in Table 8.

The basic difference between the HD6801 and the HD68P01 is that the HD6801 has an on-chip ROM while the HD68P01 has

an on the package EPROM. The HD68P01 is pin and code compatible with the HD6801 and can be used to emulate the HD6801, allowing easy software development using the on-package EPROM. Software developed using the HD68P01 can then be masked into the HD6801 ROM.

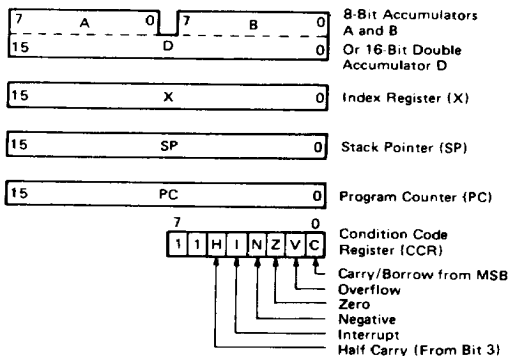

Figure 10 HD68P01 Programming Model

■ INTERRUPTS

The MCU supports two types of interrupt requests: maskable and non-maskable. A Non-Maskable Interrupt (NMI) is always recognized and acted upon at the completion of the current instruction. Maskable interrupts are controlled by the Condition Code Register's I-bit and by individual enable bits. The I-bit controls all maskable interrupts. Of the maskable interrupts, there are two types: IRQ_1 and IRQ_2 . The Programmable Timer and Serial Communications Interface use an internal IRQ_2 interrupt line, as shown in BLOCK DIAGRAM. External devices (and IS3) use IRQ_1 . An IRQ_1 interrupt is serviced before IRQ_2 if both are pending.

All IRQ_2 interrupts use hardware prioritized vectors. The single SCI interrupt and three timer interrupts are serviced in a prioritized order where each is vectored to a separate location. All MCU interrupt vector locations are shown in Table 1.

The Interrupt flowchart is depicted in Figure 13 and is common to every MCU interrupt excluding Reset. The Program Counter, Index Register, A Accumulator, B Accumulator, and Condition Code Register are pushed to the stack. The I-bit is

set to inhibit maskable interrupts and a vector is fetched corresponding to the current highest priority interrupt. The vector is transferred to the Program Counter and instruction execution is resumed. Interrupt and RES timing is illustrated in Figure 11 and 12.

Table 1 Interrupt Vector Locations

MSB	LSB	Interrupt
FFFE	FFFF	RES
FFFC	FFFD	NMI
FFFA	FFFB	Software Interrupt (SWI)
FFF8	FFF9	IRQ_1 (or IS3)
FFF6	FFF7	ICF (Input Capture)
FFF4	FFF5	OCF (Output Compare)
FFF2	FFF3	TOF (Timer Overflow)
FFF0	FFF1	SCI (RDRF + ORFE + TDRE)

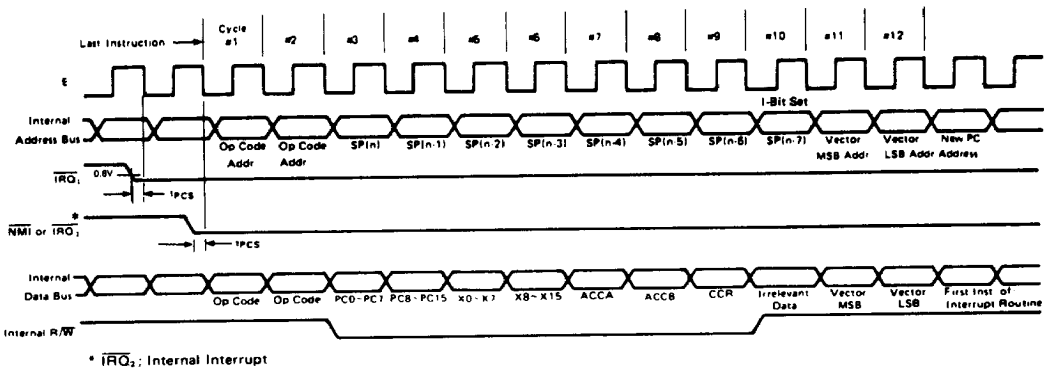

Figure 11 Interrupt Sequence

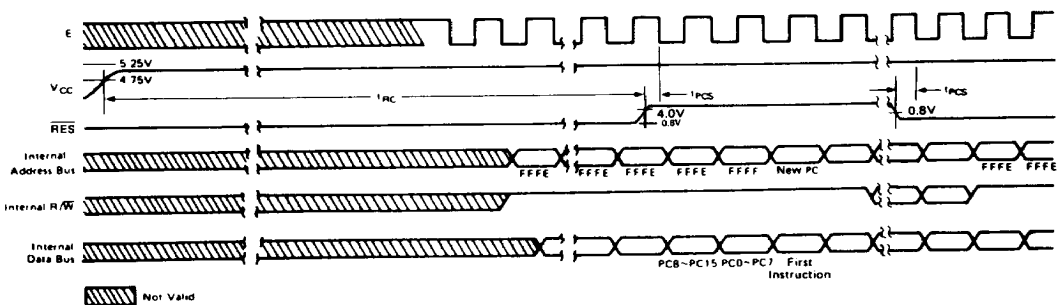

Figure 12 Reset Timing



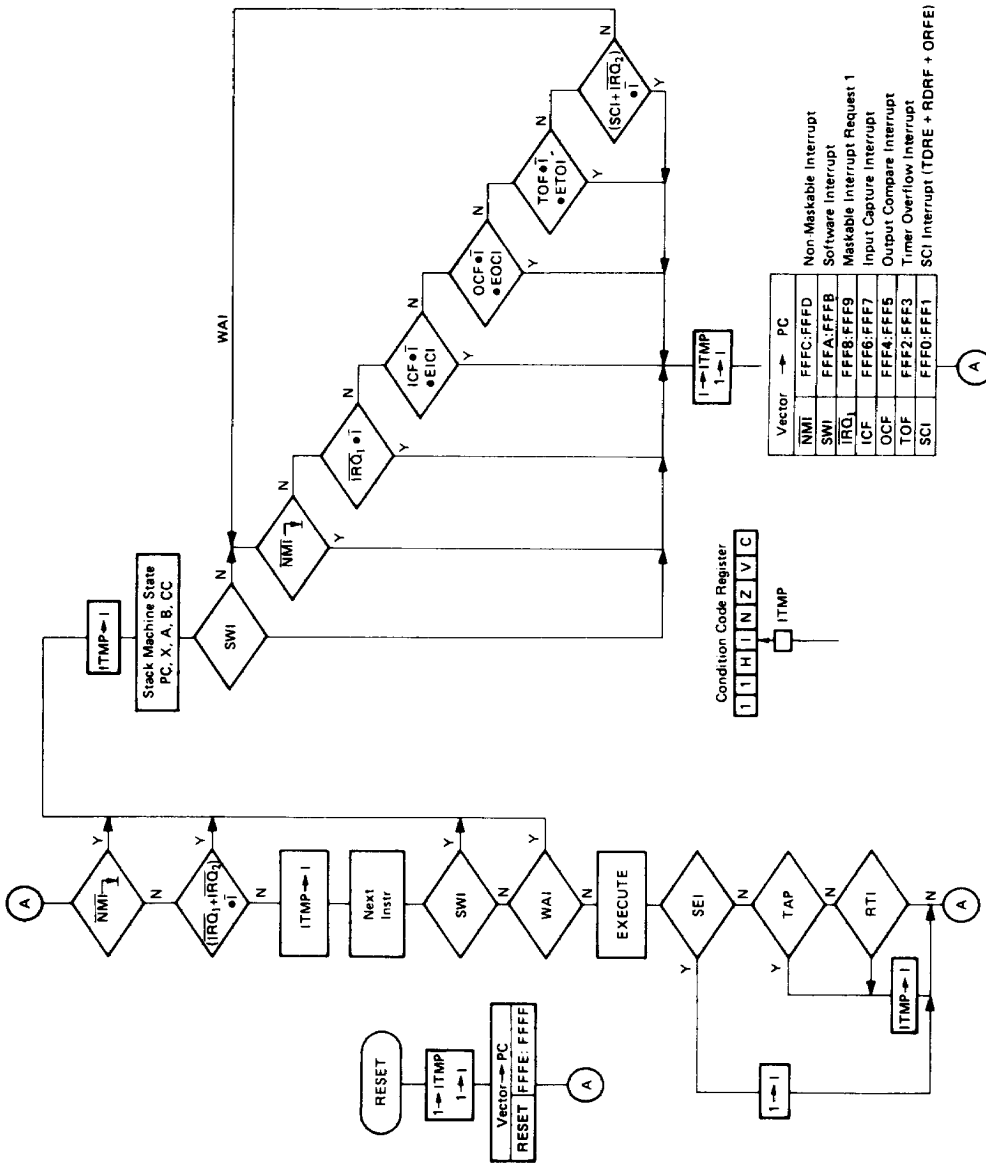

Figure 13 Interrupt Flowchart



■ FUNCTIONAL PIN DESCRIPTIONS

● **V_{CC} and V_{SS}**
 V_{CC} and V_{SS} provide power to a large portion of the MCU. The power supply should provide +5 volts (±5%) to V_{CC}, and V_{SS} should be tied to ground. Total power dissipation (including V_{CC} Standby), will not exceed P_D milliwatts.

● **V_{CC} Standby**
 V_{CC} Standby provides power to the standby portion (\$80 through \$BF) of the RAM and the STBY PWR and RAME bits of the RAM Control Register. Voltage requirements depend on whether the MCU is in a powerup or powerdown state. In the powerup state, the power supply should provide +5 volts (±5%) and must reach V_{SB} volts before RES reaches 4.0 volts. During powerdown, V_{CC} Standby must remain above V_{SB} (min) to sustain the standby RAM and STBY PWR bit. While in powerdown operation, the standby current will not exceed I_{SB}.

It is typical to power both V_{CC} and V_{CC} Standby from the same source during normal operation. A diode must be used between them to prevent supplying power to V_{CC} during powerdown operation. V_{CC} Standby should be tied to either ground or V_{CC} in Mode 3.

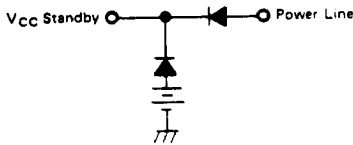

Figure 14 Battery Backup for V_{CC} Standby

● **RAM Control Register (\$14)**

The RAM Control Register includes two bits which can be used to control RAM accesses and determine the adequacy of the standby power source during powerdown operation. It is intended that RAME be cleared and STBY PWR be set as part of a powerdown procedure.

RAM Control Register							
7	6	5	4	3	2	1	0
STBY PWR	RAME	X	X	X	X	X	X

Bit 0~5 Not Used
 Bit 6 RAME

RAM Enable. This Read/Write bit can be used to remove the entire RAM from the internal memory map. RAME is set (enabled) during Reset provided standby power is available on the positive edge of RES. If RAME is clear, any access to a RAM address is external. If RAME is set and not in Mode 3, the RAM is included in the internal map.

Bit 7 STBY PWR

Standby Power. This bit is a Read/Write status bit which is cleared whenever V_{CC} Standby decreases below V_{SB} (min). It can be set only by software and is not affected by RES.

● **XTAL and EXTAL**

These two input pins interface either a crystal or TTL com-

patible clock to the MCU's internal clock generator. Divide-by-four circuitry is included which allows use of the inexpensive 3.58 MHz Color Burst TV crystals. A 22 pF capacitor is required from each crystal pin to ground to ensure reliable startup and operation. Alternatively, EXTAL may be driven with an external TTL compatible clock with a duty cycle of 45% ~ 55% with XTAL connected to ground.

The internal oscillator is designed to interface with an AT-cut quartz crystal resonator or a ceramic resonator operated in parallel resonance mode in the frequency range specified for 3.2 ~ 4 MHz. The crystal should be mounted as close as possible to the input pins to minimize output distortion and startup stabilization time. The MCU is compatible with most commercially available crystals and ceramic resonators and nominal crystal parameters are shown in Figure 15.

● **RES**

This input is used to reset the MCU's internal state and provide an orderly startup procedure. During powerup, RES must be held below 0.8 volts: (1) at least t_{RC} after V_{CC} reaches 4.75 volts in order to provide sufficient time for the clock generator to stabilize, and (2) until V_{CC} Standby reaches 4.75 volts. RES must be held low at least three E-cycles if asserted during powerup operation.

When a "High" level is detected, the MCU does the following:

- 1) All the higher order address lines will be forced "High".
- 2) I/O Port 2 bits, 2, 1, and 0 are latched into programmed control bits PC2, PC1 and PC0.
- 3) The last two (\$FFFE, \$FFFF) locations in memory will be used to load the program addressed by the program counter.
- 4) The interrupt mask bit is set; must be cleared before the CPU can recognize maskable interrupts.

● **E (Enable)**

This is an output clock used primarily for bus synchronization. It is TTL compatible and is the slightly skewed divide-by-four result of the MCU input frequency. It will drive one Schottky TTL load and 90 pF, and all data given in cycles is referenced to this clock unless otherwise noted.

● **NMI (Non-Maskable Interrupt)**

An NMI negative edge request an CPU interrupt sequence, but the current instruction will be completed before it responds to the request. The CPU will then begin an interrupt sequence. Finally, a vector is fetched from \$FFFC and \$FFFD, transferred to the Program Counter and instruction execution resumes. NMI typically requires a 3.3 kΩ (nominal) resistor to V_{CC}. There is no internal NMI pullup resistor. NMI must be held low for at least one E-cycle to be recognized under all conditions.

● **IRQ₁ (Maskable Interrupt Request 1)**

IRQ₁ is a level-sensitive input which can be used to request an interrupt sequence. The CPU will complete the current instruction before it responds to the request. If the interrupt mask bit (I-bit) in the Condition Code Register is clear, the CPU will begin an interrupt sequence. Finally, a vector is fetched from \$FFF8 and \$FFF9, transferred to the Program Counter, and instruction execution is resumed.

IRQ₁ typically requires an external 3.3 kΩ (nominal) resistor to V_{CC} for wire-OR application. IRQ₁ has no internal pullup resistor.



• **SC₁ and SC₂ (Strobe Control 1 and 2)**

The function of SC₁ and SC₂ depends on the operating mode. SC₁ is configured as an output in all modes except single chip mode, whereas SC₂ is always an output. SC₁ and SC₂ can drive one Schottky load and 90 pF.

SC₁ and SC₂ in Single Chip Mode

In Single Chip Modes, SC₁ and SC₂ are configured as an input and output, respectively, and both function as Port 3 control lines. SC₁ functions as IS₃ and can be used to indicate that Port 3 input data is ready or output data has been accepted. Three options associated with IS₃ are controlled by Port 3's Control and Status Register and are discussed in Port 3's description. If unused, IS₃ can remain unconnected.

SC₂ is configured as OS₃ and can be used to strobe output data or acknowledge input data. It is controlled by Output Strobe Select (OSS) in Port 3's Control and Status Register. The strobe is generated by a read (OSS = 0) or write (OSS = 1) to Port 3's Data Register. OS₃ timing is shown in Figure 5.

SC₁ and SC₂ in Expanded Non-Multiplexed Mode

In the Expanded Non-Multiplexed Mode, both SC₁ and SC₂ are configured as outputs. SC₁ functions as Input/Output Select (IOS) and is asserted only when \$0100 through \$01FF is sensed on the internal address bus.

SC₂ is configured as Read/Write and is used to control the direction of data bus transfers. An CPU read is enabled when Read/Write and E are high.

SC₁ and SC₂ in Expanded Multiplexed Mode

In the Expanded Multiplexed Modes, both SC₁ and SC₂ are configured as outputs. SC₁ functions as Address Strobe and can be used to demultiplex the eight least significant addresses and the data bus. A latch controlled by Address Strobe captures address on the negative edge, as shown in Figure 20.

SC₂ is configured as Read/Write and is used to control the direction of data bus transfers. An CPU read is enabled when Read/Write and E are high.

Nominal Crystal Parameter

Crystal Item	4 MHz	5 MHz
Co	7 pF max.	4.7 pF max.
R _s	60Ω max.	30Ω typ.

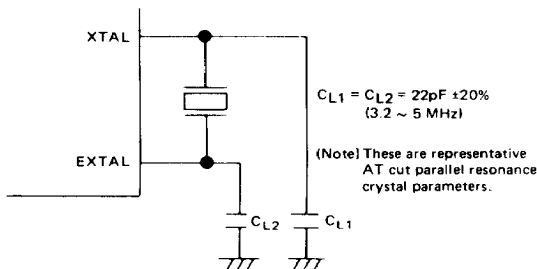

(a) Nominal Recommended Crystal Parameters

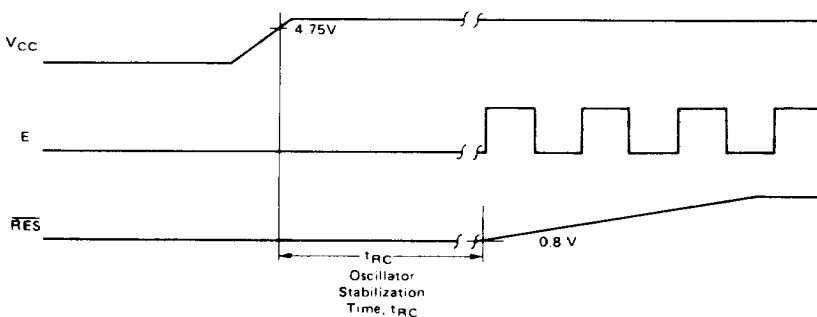
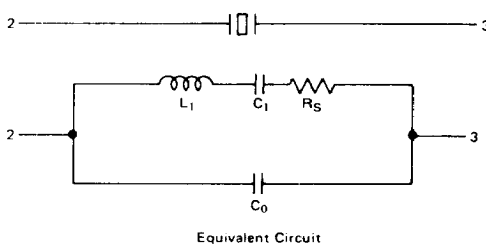

(b) Oscillator Stabilization Time (t_{RC})

Figure 15 Oscillator Characteristics



■ PORTS

There are four I/O ports on the MCU; three 8-bit ports and one 5-bit port. There are two control lines associated with one of the 8-bit ports. Each port has an associated write only Data Direction Register which allows each I/O line to be programmed to act as an input or an output. A "1" in the corresponding Data Direction Register bit will cause that I/O line to be an output. A "0" in the corresponding Data Direction Register bit will cause the I/O line to be an input. There are four ports: Port 1, Port 2, Port 3, and Port 4. Their addresses and the addresses of their Data Direction registers are given in Table 2.

Table 2 Port and Data Direction Register Addresses

Ports	Port Address	Data Direction Register Address
I/O Port 1	\$0002	\$0000
I/O Port 2	\$0003	\$0001
I/O Port 3	\$0006	\$0004
I/O Port 4	\$0007	\$0005

● P₁₀~P₁₇ (Port 1)

Port 1 is a mode independent 8-bit I/O port where each line is an input or output as defined by its Data Direction Register. The TTL compatible three-state output buffers can drive one Schottky TTL load and 30 pF, Darlington transistors, or CMOS devices using external pullup resistors. It is configured as a data input port by RES. Unused lines can remain unconnected.

● P₂₀~P₂₄ (Port 2)

Port 2 is a mode independent 5-bit I/O port where each line is configured by its Data Direction Register. During RES, all lines are configured as inputs. The TTL compatible three-state output buffers can drive one Schottky TTL load and 30 pF or CMOS devices using external pullup resistors. P₂₀, P₂₁ and P₂₂ must always be connected to provide the operating mode. If lines P₂₃ and P₂₄ are unused, they can remain unconnected.

P₂₀, P₂₁, and P₂₂ provide the operating mode which is latched into the Program Control Register on the positive edge of RES. The mode may be read from Port 2 Data Register as shown where PC₂ is latched from pin 10.

Port 2 also provides an interface for the Serial Communications Interface and Timer. Bit 1, if configured as an output, is dedicated to the timer's Output Compare function and cannot be used to provide output from Port 2 Data Register.

Port 2 Data Register

7	6	5	4	3	2	1	0
PC ₂	PC ₁	PC ₀	P ₂₄	P ₂₃	P ₂₂	P ₂₁	P ₂₀

\$0003

● P₃₀~P₃₇ (Port 3)

Port 3 can be configured as an I/O port, a bidirectional 8-bit data bus, or a multiplexed address/data bus depending on the operating mode. The TTL compatible three-state output buffers can drive one Schottky TTL load and 90 pF. Unused lines can remain unconnected.

Port 3 in Single-Chip Mode

Port 3 is an 8-bit I/O port in Single-Chip Mode where each line is configured by its Data Direction Register. There are also

two lines, $\overline{IS3}$ and $\overline{OS3}$, which can be used to control Port 3 data transfers.

Three Port 3 options are controlled by the Port 3 Control and Status Register and available only in Single-Chip Mode: (1) Port 3 input data can be latched using $\overline{IS3}$ as a control signal, (2) $\overline{OS3}$ can be generated by either an CPU read or write to Port 3's Data Register, and (3) an $\overline{IRQ_1}$ interrupt can be enabled by an $\overline{IS3}$ negative edge. Port 3 latch timing is shown in Figure 6.

Port 3 Control and Status Register

7	6	5	4	3	2	1	0
$\overline{IS3}$ Flag	$\overline{IS3}$ $\overline{IRQ_1}$ Enable	X	OSS	Latch Enable	X	X	X

\$000F

Bit 0~2

Not used.

Bit 3

LATCH ENABLE. This bit controls the input latch for Port 3. If set, input data is latched by an $\overline{IS3}$ negative edge. The latch is transparent after a read of Port 3's Data Register. LATCH ENABLE is cleared by RES.

Bit 4

OSS (Output Strobe Select). This bit determines whether $\overline{OS3}$ will be generated by a read or write of Port 3's Data Register. When clear, the strobe is generated by a read; when set, it is generated by a write. OSS is cleared by RES.

Bit 5

Not used.

Bit 6

$\overline{IS3}$ $\overline{IRQ_1}$ ENABLE. When set, an $\overline{IRQ_1}$ interrupt will be enabled whenever $\overline{IS3}$ FLAG is set; when clear, the interrupt is inhibited. This bit is cleared by RES.

Bit 7

$\overline{IS3}$ FLAG. This read-only status bit is set by an $\overline{IS3}$ negative edge. It is cleared by a read of the Port 3 Control and Status Register (with $\overline{IS3}$ FLAG set) followed by a read or write to Port 3's Data Register or by RES.

Port 3 in Expanded Non-Multiplexed Mode

Port 3 is configured as a bidirectional data bus (D₀~D₇) in the Expanded Non-Multiplexed Mode. The direction of data transfers is controlled by Read/Write (SC₂) and clocked by E (Enable).

Port 3 in Expanded Multiplexed Mode

Port 3 is configured as a time multiplexed address (A₀~A₇) and data bus (D₀~D₇) in Expanded Multiplexed Mode where Address Strobe (AS) can be used to demultiplex the two buses. Port 3 is held in a high impedance state between valid address and data to prevent potential bus conflicts.

● P₄₀~P₄₇ (Port 4)

Port 4 is configured as an 8-bit I/O port, address outputs, or data inputs depending on the operating mode. Port 4 can drive one Schottky TTL load and 90 pF and is the only port with internal pullup resistors. Unused lines can remain unconnected.

Port 4 in Single Chip Mode

In Single Chip Mode, Port 4 functions as an 8-bit I/O port where each line is configured by its Data Direction Register.



Internal pullup resistors allow the port to directly interface with CMOS at 5 volt levels. External pullup resistors to more than 5 volts, however, cannot be used.

Port 4 in Expanded Non-Multiplexed Mode

Port 4 is configured from RES as an 8-bit input port where its Data Direction Register can be written to provide any or all of address lines, A₀ to A₇. Internal pullup resistors are intended to pull the lines high until its Data Direction Register is configured.

Port 4 in Expanded Multiplexed Mode

In all Expanded Multiplexed modes except Mode 6, Port 4 functions as half of the address bus and provides A₈ to A₁₅. In Mode 6, the port is configured from RES as an 8-bit parallel input port where its Data Direction Register can be written to provide any or all of address lines, A₈ to A₁₅. Internal pullup resistors are intended to pull the lines high until its Data Direction Register is configured where bit 0 controls A₈.

■ **OPERATING MODES**

The MCU provides eight different operating modes which are selectable by hardware programming and referred to as Mode 0 through Mode 7. The operating mode controls the memory map, configuration of Port 3, Port 4, SC₁, SC₂, and the physical location of interrupt vectors.

● **Fundamental Modes**

The MCU's eight modes can be grouped into three fundamental modes which refer to the type of bus it supports: Single Chip, Expanded Non-Multiplexed, and Expanded Multiplexed. Single chip modes include 4 and 7, Expanded Non-Multiplexed is Mode 5 and the remaining five are Expanded Multiplexed modes. Table 3 summarizes the characteristics of the operating modes.

Single Chip Modes (4, 7)

In Single-Chip Mode, the MCU's four ports are configured as parallel input/output data ports, as shown in Figure 16. The MCU functions as a monolithic microcomputer in these two modes without external address or data buses. A maximum of 29 I/O lines and two Port 3 control lines are provided. In addition to other peripherals, another MCU can be interfaced to Port 3 in a loosely coupled dual processor configuration, as shown in Figure 17.

In Single-Chip Test Mode (4), the RAM responds to \$XX80 through \$XFF and the ROM is removed from the internal address map. A test program must first be loaded into the RAM using modes 0, 1, 2, or 6. If the MCU is Reset and then programmed into Mode 4, execution will begin at \$XFE: XFFF. Mode 5 can be irreversibly entered from Mode 4 without going through Reset by setting bit 5 of Port 2's Data Register. This mode is used primarily to test Ports 3 and 4 in the Single-Chip and Non-Multiplexed Modes.

Expanded Non-Multiplexed Mode (5)

A modest amount of external memory space is provided in the Expanded Non-Multiplexed Mode while retaining significant on-chip resources. Port 3 functions as an 8-bit bidirectional data bus and Port 4 is configured as an input data port. Any combination of the eight least-significant address lines may be obtained by writing to Port 4's Data Direction Register. Stated alternatively, any combination of A₀ to A₇ may be provided while retaining the remainder as input data lines. Internal pull-

up resistors are intended to pull Port 4's lines high until it is configured.

Figure 18 illustrates a typical system configuration in the Expanded Non-Multiplexed Mode. The MCU interfaces directly with HMCS6800 family parts and can access 256 bytes of external address space at \$100 through \$1FF. IOS provides an address decode of external memory (\$100-\$1FF) and can be used similarly to an address or chip select line.

Table 3 Summary of HD6800 Operating Modes

Common to all Modes:	
Reserved Register Area	
Port 1	
Port 2	
Programmable Timer	
Serial Communication Interface	
Single Chip Mode 7	
128 bytes of RAM; 2048 bytes of ROM	
Port 3 is a parallel I/O port with two control lines	
Port 4 is a parallel I/O port	
SC ₁ is Input Strobe 3 (IS3)	
SC ₂ is Output Strobe 3 (OS3)	
Expanded Non-Multiplexed Mode 5	
128 bytes of RAM; 2048 bytes of ROM	
256 bytes of external memory space	
Port 3 is an 8-bit data bus	
Port 4 is an input port/address bus	
SC ₁ is Input/Output Select (IOS)	
SC ₂ is read/write (R/W)	
Expanded Multiplexed Modes 1, 2, 3, 6	
Four memory space options (65k address space):	
(1) No internal RAM or ROM (Mode 3)	
(2) Internal RAM, no ROM (Mode 2)	
(3) Internal RAM and ROM (Mode 1)	
(4) Internal RAM, ROM with partial address bus (Mode 6)	
Port 3 is a multiplexed address/data bus	
Port 4 is an address bus (inputs/address in Mode 6)	
SC ₁ is Address Strobe (AS)	
SC ₂ is Read/Write (R/W)	
Test Modes 0 and 4	
Expanded Multiplexed Test Mode 0	
May be used to test RAM and ROM	
Single Chip and Non-Multiplexed Test Mode 4	
(1) May be changed to Mode 5 without going through Reset	
(2) May be used to test Ports 3 and 4 as I/O ports	

Expanded-Multiplexed Modes (0, 1, 2, 3, 6)

In the Expanded-Multiplexed Modes, the MCU has the ability to access a 65k bytes memory space. Port 3 functions as a time multiplexed address/data bus with address valid on the negative edge of Address Strobe (AS) and the data bus valid while E is high. In Modes 0 to 3, Port 4 provides address lines A₈ to A₁₅. In Mode 6, however, Port 4 is configured during RES as data port inputs and the Data Direction Register can be changed to provide any combination of address lines, A₈ to A₁₅. Stated alternatively, any subset of A₈ to A₁₅ can be provided while retaining the remainder as input data lines. Internal pullup resistors are intended to pull Port 4's lines high until software configures the port.

Figure 19 depicts a typical configuration for the Expanded-Multiplexed Modes. Address Strobe can be used to control a transparent D-type latch to capture addresses A₀ to A₇, as shown in Figure 20. This allows Port 3 to function as a Data Bus when E is high.

In Mode 0, the Reset vector is external for the first two E-cycles after the positive edge of RES and internal thereafter. In



in addition, the internal and external data buses are connected and there must be no memory map overlap to avoid potential bus conflicts. Mode 0 is used primarily to verify the ROM pattern

and monitor the internal data bus with the automated test equipment.

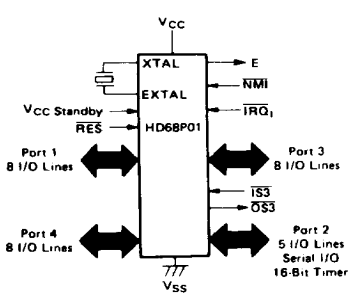

Figure 16 Single Chip Mode

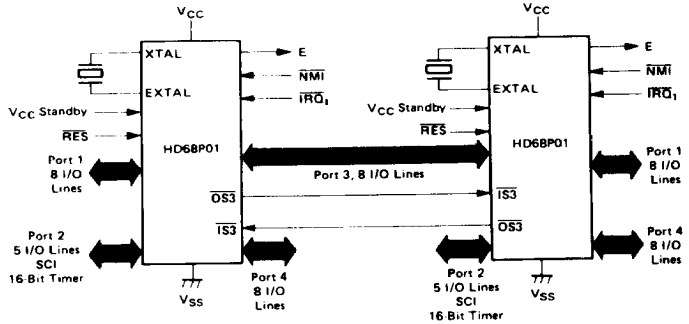

Figure 17 Single Chip Dual Processor Configuration

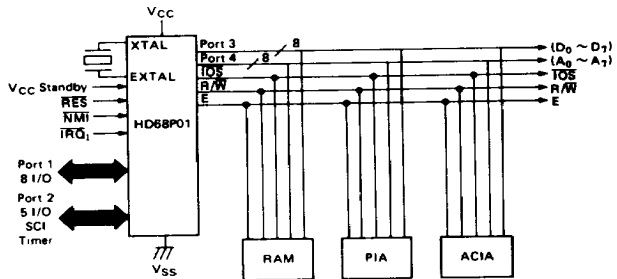
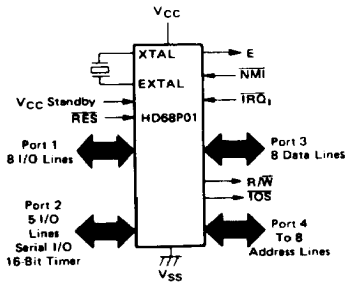

Figure 18 Expanded Non-Multiplexed Configuration

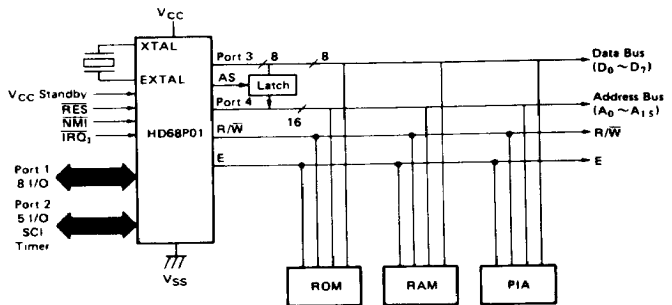
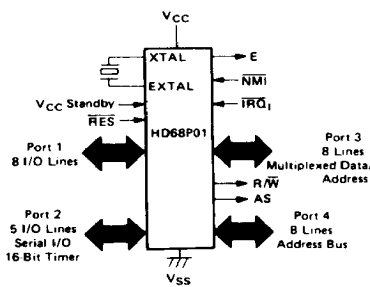

Figure 19 Expanded Multiplexed Configuration



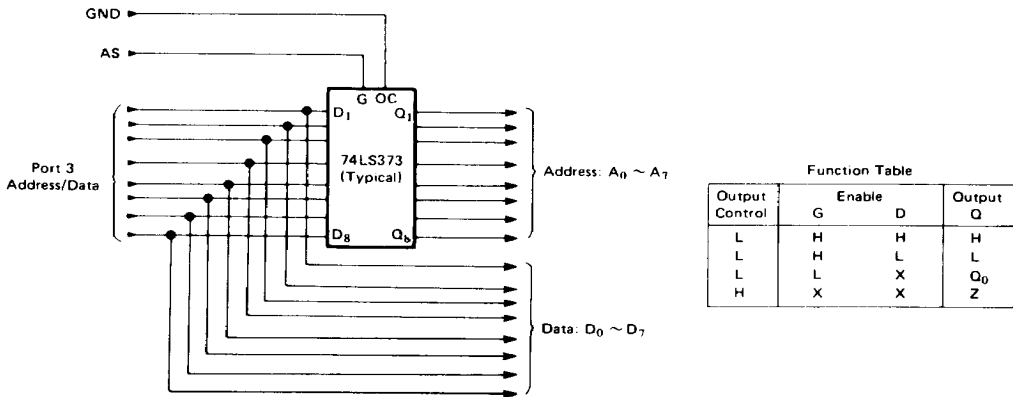

Figure 20 Typical Latch Arrangement

• **Programming The Mode**

The operating mode is programmed by the levels asserted on P₂₂, P₂₁, and P₂₀ which are latched into PC2, PC1, and PC0 of the program control register on the positive edge of RES. The operating mode may be read from Port 2 Data Register as shown below, and programming levels and timing must be met as shown in Figure 8. A brief outline of the operating modes is shown in Table 4.

Circuitry to provide the programming levels is dependent primarily on the normal system usage of the three pins. If configured as outputs, the circuit shown in Figure 21 may be used; otherwise, three-state buffers can be used to provide isolation while programming the mode.

Port 2 Data Register

7	6	5	4	3	2	1	0	\$0003
PC2	PC1	PC0	P24	P23	P22	P21	P20	

Table 4 Mode Selection Summary

Mode	P ₂₂ (PC2)	P ₂₁ (PC1)	P ₂₀ (PC0)	ROM	RAM	Interrupt Vectors	Bus Mode	Operating Mode
7	H	H	H	I	I	I	I	Single Chip
6	H	H	L	I	I	I	MUX ^(5, 6)	Multiplexed/Partial Decode
5	H	L	H	I	I	I	NMUX ^(5, 6)	Non-Multiplexed/Partial Decode
4	H	L	L	I ⁽²⁾	I ⁽¹⁾	I	I	Single Chip Test
3	L	H	H	E	E	E	MUX ⁽⁴⁾	Multiplexed /No RAM or ROM
2	L	H	L	E	I	E	MUX ⁽⁴⁾	Multiplexed /RAM
1	L	L	H	I	I	E	MUX ⁽⁴⁾	Multiplexed/RAM & ROM
0	L	L	L	I	I	I ⁽³⁾	MUX ⁽⁴⁾	Multiplexed Test

Legend:

- I – Internal
- E – External
- MUX – Multiplexed
- NMUX – Non-Multiplexed
- L – Logic “0”
- H – Logic “1”

Notes:

- (1) Internal ROM is addressed at \$XX80
- (2) Internal ROM is disabled
- (3) RES vector is external for 2 cycles after RES goes high
- (4) Addresses associated with Ports 3 and 4 are considered external in Modes 0, 1, 2, and 3
- (5) Addresses associated with Port 3 are considered external in Modes 5 and 6
- (6) Port 4 default is user data input; address output is optional by writing to Port 4 Data Direction Register



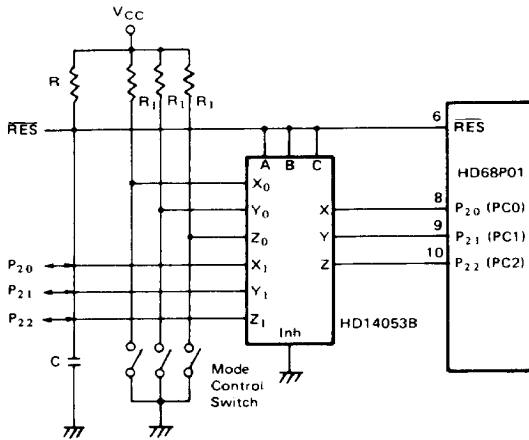

- [NOTES] 1) Mode 7 as shown
 2) $RC \approx$ Reset time constant
 3) $R_1 = 10k\Omega$

Figure 21 Recommended Circuit for Mode Selection

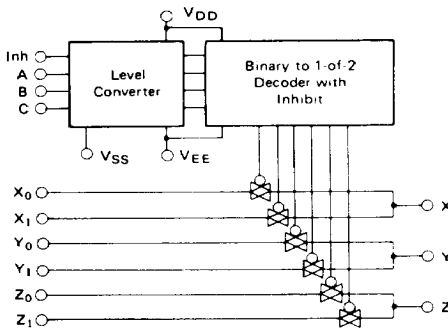

Truth Table						
Control Input			On Switch			
Inhibit	Select			HD14053B		
	C	B	A	Z ₀	Y ₀	X ₀
0	0	0	0	Z ₀	Y ₀	X ₀
0	0	0	1	Z ₀	Y ₀	X ₁
0	0	1	0	Z ₀	Y ₁	X ₀
0	0	1	1	Z ₀	Y ₁	X ₁
0	1	0	0	Z ₁	Y ₀	X ₀
0	1	0	1	Z ₁	Y ₀	X ₁
0	1	1	0	Z ₁	Y ₁	X ₀
0	1	1	1	Z ₁	Y ₁	X ₁
1	X	X	X	-	-	-

Figure 22 HD14053B Multiplexers/Demultiplexers



■ MEMORY MAPS

The MCU can provide up to 65k bytes address space depending on the operating mode. The HD68P01 provides 8k bytes address space for EPROM, but the maps differ in EPROM types as follows.

1) HN482732A (a 4k-byte EPROM)

In order to support the HD6801V0, EPROM of the HD68P01V07/HD68P01V07-1 must be located at \$F000-\$FFFF.

2) HN482764 (a 8k-byte EPROM)

The HD68P01M0/HD68P01M0-1 can provide up to 8k bytes address space using HN482764 instead of HN482732A. In this case, EPROM of the HD68P01M0/HD68P01M0-1 is located at \$E000-\$FFFF.

A memory map for each operating mode is shown in Figure 23. The first 32 locations of each map are reserved for the MCU's internal register area, as shown in Table 5, with exceptions as indicated.

Refer to "Precaution when emulating the HD6801 Family".

Table 5 Internal Register Area

Register	Address
Port 1 Data Direction Register***	00
Port 2 Data Direction Register***	01
Port 1 Data Register	02
Port 2 Data Register	03
Port 3 Data Direction Register***	04*
Port 4 Data Direction Register***	05**
Port 3 Data Register	06*
Port 4 Data Register	07**
Timer Control and Status Register	08
Counter (High Byte)	09
Counter (Low Byte)	0A
Output Compare Register (High Byte)	0B
Output Compare Register (Low Byte)	0C
Input Capture Register (High Byte)	0D
Input Capture Register (Low Byte)	0E
Port 3 control and Status Register	0F*
Rate and Mode Control Register	10
Transmit/Receive Control and Status Register	11
Receive Data Register	12
Transmit Data Register	13
RAM Control Register	14
Reserved	15-1F

* External address in Modes 0, 1, 2, 3, 5, 6; cannot be accessed in Mode 5 (No I/O)

** External addresses in Modes 0, 1, 2, 3

*** 1 = Output, 0 = Input



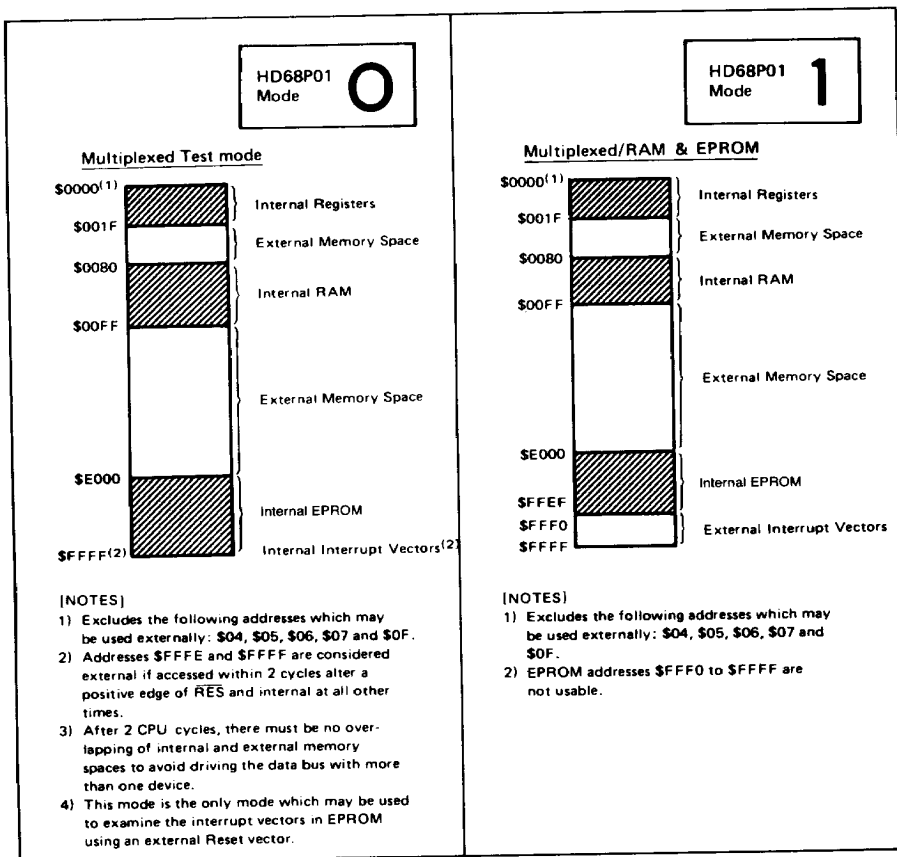

Figure 23 HD68P01 Memory Maps

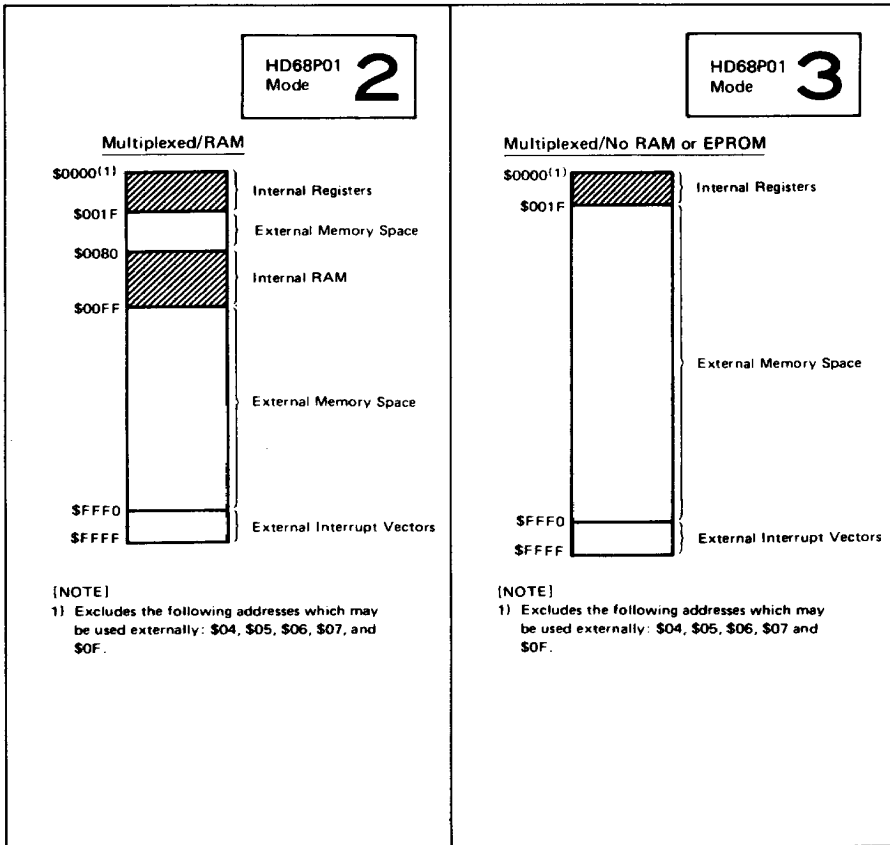

Figure 23 HD68P01 Memory Maps (Continued)



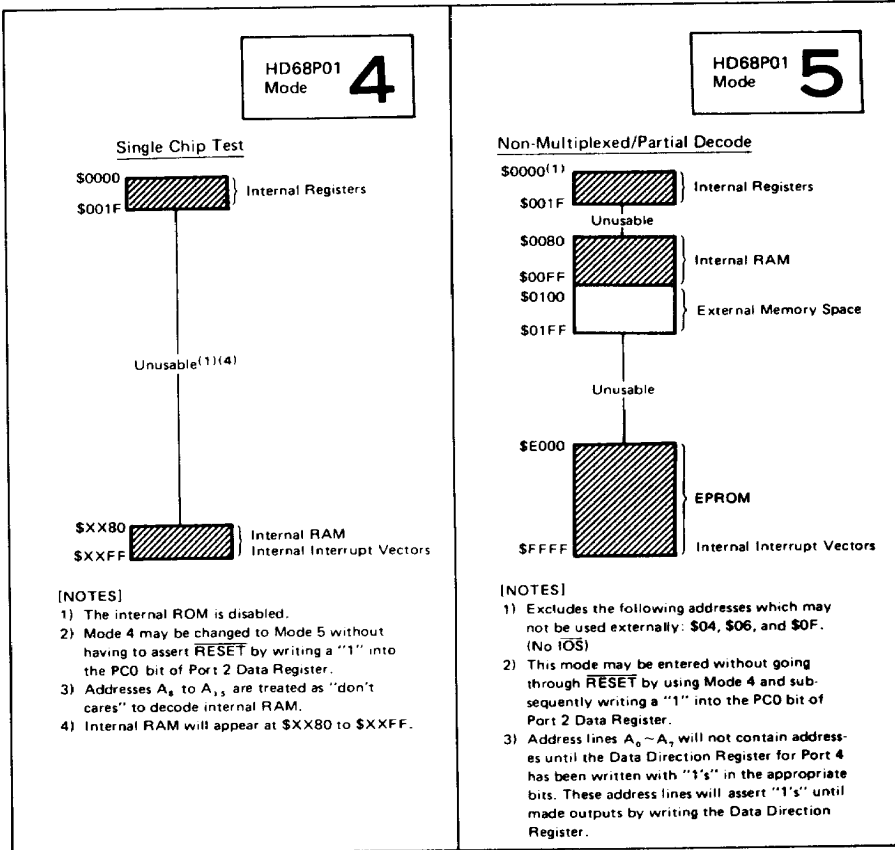

Figure 23 HD68P01 Memory Maps (Continued)

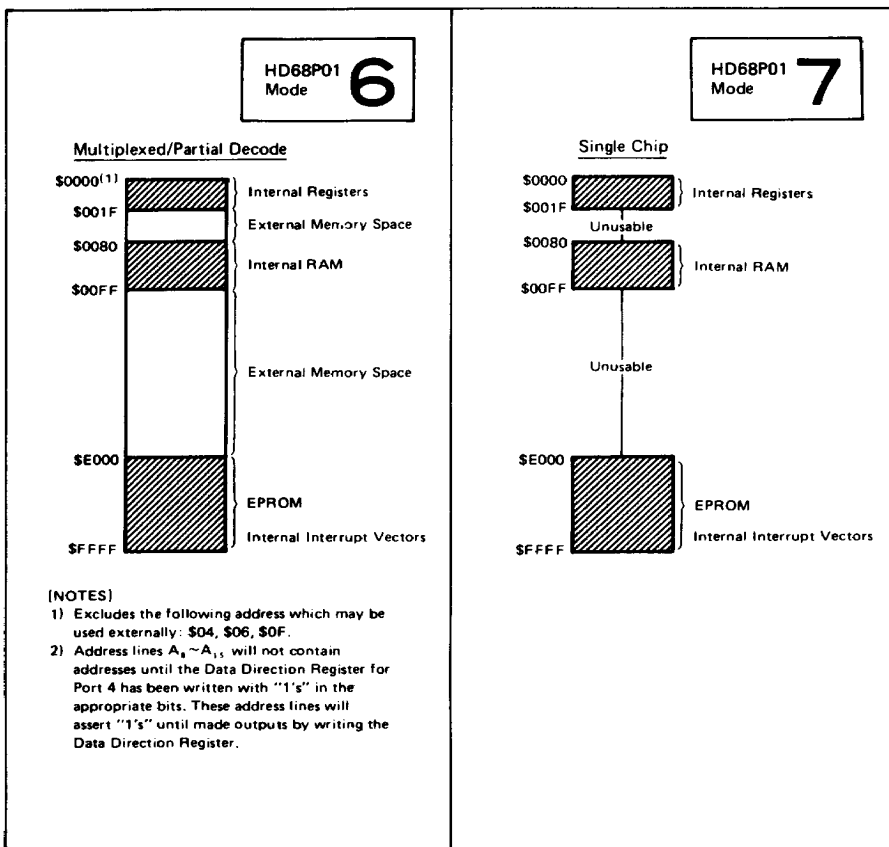

Figure 23 HD68P01 Memory Maps (Continued)



■ **PROGRAMMABLE TIME**

The Programmable Timer can be used to perform input waveform measurements while independently generating an output waveform. Pulse widths can vary from several microseconds to many seconds. A block diagram of the Timer is shown in Figure 24.

● **Counter (\$09:0A)**

The key timer element is a 16-bit free-running counter which is incremented by E (Enable). It is cleared during RES and is read-only with one exception: a write to the counter (\$09) will preset it to \$FFF8. This feature, intended for testing, can disturb serial operations because the counter provides the SCI's internal bit rate clock. TOF is set whenever the counter contains all 1's.

● **Output Compare Register (\$0B:0C)**

The Output Compare Register is a 16-bit Read/Write register used to control an output waveform or provide an arbitrary timeout flag. It is compared with the free-running counter on each E-cycle. When a match is found, OCF is set and OLVL is clocked to an output level register. If Port 2, bit 1, is configured as an output, OLVL will appear at P₂₁ and the Output Compare Register and OLVL can then be changed for the next compare. The function is inhibited for one cycle after a write to its high byte of the Compare Register (\$0B) to ensure a valid compare.

The Output Compare Register is set to \$FFFF by RES.

● **Input Capture Register (\$0D:0E)**

The Input Capture Register is a 16-bit read-only register used to store the free-running counter when a "proper" input transition occurs as defined by IEDG. Port 2, bit 0 should be configured as an input, but the edge detect circuit always senses P₂₀ even when configured as an output. An input capture can occur independently of ICF: the register always contains the most current value. Counter transfer is inhibited, however, between accesses of a double byte CPU read. The input pulse width must be at least two E-cycles to ensure an input capture under all conditions.

● **Timer Control and Status Register (\$08)**

The Timer Control and Status Register (TCSR) is an 8-bit register of which all bits are readable while bits 0~4 can be written. The three most significant bits provide the timer's status and indicate if:

- a proper level transition has been detected,
- a match has been found between the free-running counter and the output compare register, and
- the free-running counter has overflowed.

Each of the three events can generate an \overline{IRQ}_2 interrupt and is controlled by an individual enable bit in the TCSR.

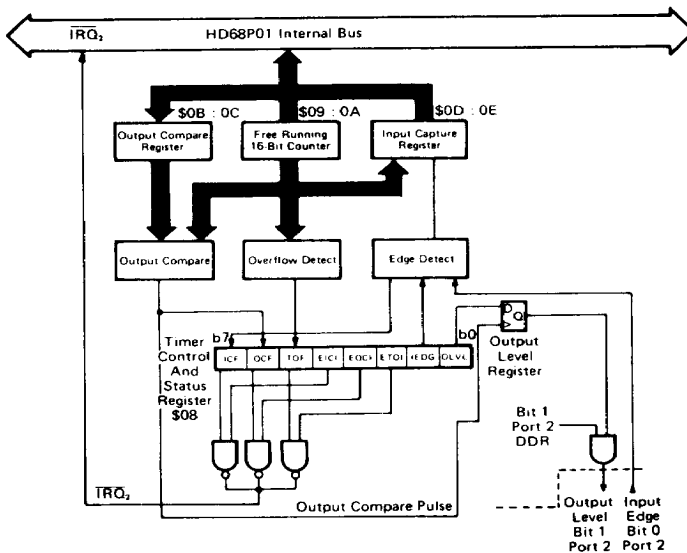

Figure 24 Block Diagram of Programmable Timer



Timer Control and Status Register (TCSR)

7	6	5	4	3	2	1	0	\$0008
ICF	OCF	TOF	EICI	EOCI	ETOI	IEDG	OLVL	

- Bit 0 OLVL** Output level. OLVL is clocked to the output level register by a successful output compare and will appear at P₂₁ if Bit 1 of Port 2's Data Direction Register is set. It is cleared by RES.
- Bit 1 IEDG** Input Edge. IEDG is cleared by RES and controls which level transition will trigger a counter transfer to the Input Capture Register:
IEDG = 0 Transfer on a negative-edge
IEDG = 1 Transfer on a positive-edge.
- Bit 2 ETOI** Enable Timer Overflow Interrupt. When set, an IRQ₂ interrupt is enabled for a timer overflow; when clear, the interrupt is inhibited. It is cleared by RES.
- Bit 3 EOCI** Enable Output Compare Interrupt. When set, an IRQ₂ interrupt is enabled for an output compare; when clear, the interrupt is inhibited. It is cleared by RES.
- Bit 4 EICI** Enable Input Capture Interrupt. When set, an IRQ₂ interrupt is enabled for an input capture; when clear, the interrupt is inhibited. It is cleared by RES.
- Bit 5 TOF** Timer Overflow Flag. TOF is set when the counter contains \$FFFF. It is cleared by reading the TCSR (with TOF set) followed by the counter's high byte (\$09), or by RES.
- Bit 6 OCF** Output Compare Flag. OCF is set when the Output Compare Register matches the free-running counter. It is cleared by reading the TCSR (with OCF set) and then writing to the Output Compare Register (\$0B or \$0C), or by RES.
- Bit 7 ICF** Input Capture Flag. ICF is set to indicate a proper level transition; it is cleared by reading the TCSR (with ICF set) and then the Input Capture Register High Byte (\$0D), or by RES.

■ SERIAL COMMUNICATIONS INTERFACE (SCI)

A full-duplex asynchronous Serial Communications Interface (SCI) is provided with a data format and a variety of rates. The SCI transmitter and receiver are functionally independent, but use the same data format and bit rate. Serial data format is standard mark/space (NRZ) and provides one start bit, eight data bits, and one stop bit. "Baud" and "bit rate" are used synonymously in the following description.

● Wake-Up Feature

In a typical serial loop multi-processor configuration, the software protocol will usually identify the address(s) at the beginning of the message. In order to permit uninterested MCU's to ignore the remainder of the message, a wake-up feature is included whereby all further SCI receiver flag (and interrupt) processing can be inhibited until its data line goes idle. An SCI receiver is re-enabled by an idle string of ten consecutive 1's or by RES. Software must provide for the required idle string between consecutive messages and prevent it within messages.

● Programmable Options

The following features of the SCI are programmable:
format: Standard mark/space (NRZ)

- clock: external or internal bit rate clock
- Baud (or bit rate): one of 4 per E-clock frequency, or external bit rate (X8) input
- wake-up feature: enabled or disabled
- interrupt requests: enabled individually for transmitter and receiver
- clock output: internal bit rate clock enabled or disabled to P₂₂
- Port 2 (bit 3, 4): dedicated or not dedicated to serial I/O individually for transmitter and receiver.

● Serial Communications Registers

The Serial Communications Interface includes four addressable registers as depicted in Figure 25. It is controlled by the Rate and Mode Control Register and the Transmit/Receive Control and Status Register. Data is transmitted and received utilizing a write-only Transmit Register and a read-only Receive Register. The shift registers are not accessible to software.

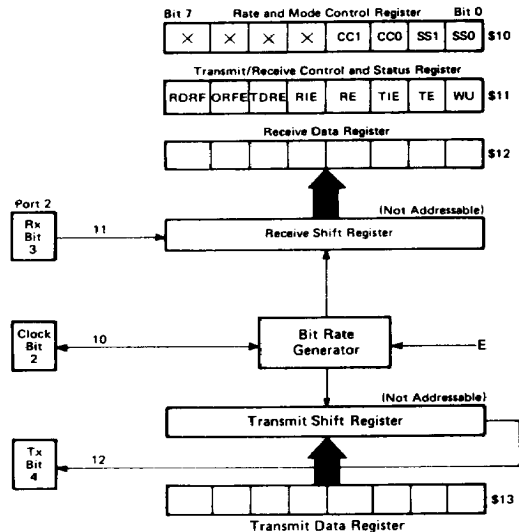

Figure 25 SCI Registers

Rate and Mode Control Register (RMCR) (\$10)

The Rate and Mode Control Register controls the SCI bit rate, format, clock source, and under certain conditions, the configuration of P₂₂. The register consists of four write-only bits which are cleared by RES. The two least significant bits control the bit rate of the internal clock and the remaining two bits control the format and clock source.

Rate and Mode Control Register (RMCR)

7	6	5	4	3	2	1	0	\$0010
X	X	X	X	CC1	CC0	SS1	SS0	



Bit 1: Bit 0 SS1:SS0 Speed Select. These two bits select the Baud when using the internal clock. Four rates may be selected which are a function of the MCU input frequency. Table 6 lists bit time and rates for three selected MCU frequencies.

Bit 3: Bit 2 CC1:CC0 Clock Control Select. These two bits select the serial clock source. If CC1 is set, the DDR value for P₂₂ is forced to the complement of CC0 and cannot be altered until CC1 is cleared. If CC1 is cleared after having been set, its DDR value is unchanged. Table 7 defines the clock source, and use of P₂₂.

If both CC1 and CC0 are set, an external TTL compatible clock must be connected to P₂₂ at eight times (8X) the desired bit rate, but not greater than E, with a duty cycle of 50% (± 10%). If CC1:CC0 = 10, the internal bit rate clock is provided at P₂₂ regardless of the values for TE or RE.

(Note) The source of SCI internal bit rate clock is the timer's free running counter. An CPU write to the counter can disturb serial operations.

Transmit/Receive Control and Status Register (TRCSR) (\$11)

The Transmit/Receive Control and Status Register controls the transmitter, receiver, wake-up feature, and two individual interrupts and monitors the status of serial operations. All eight bits are readable while bits 0 to 4 are also writable. The register is initialized to \$20 by RES.

Transmit/Receive Control and Status Register (TRCSR)

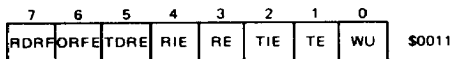

Bit 0 WU "Wake-up" on Idle Line. When set, WU enables the wake-up function; it is cleared by ten consecutive 1's or by RES. WU will not set if the line is idle.

Bit 1 TE Transmit Enable. When set, P₂₄ DDR bit is set, cannot be changed, and will remain set if TE is subsequently cleared. When TE is changed from clear to set, the transmitter is connected to P₂₄

and a preamble of nine consecutive 1's is transmitted. TE is cleared by RES.

Bit 2 TIE Transmit Interrupt Enable. When set, an \overline{IRQ}_2 interrupt is enabled when TDRE is set; when clear, the interrupt is inhibited. TE is cleared by RES.

Bit 3 RE Receive Enable. When set, P₂₃'s DDR bit is cleared, cannot be changed, and will remain clear if RE is subsequently cleared. While RE is set, the SCI receiver is enabled. RE is cleared by RES.

Bit 4 RIE Receiver Interrupt Enable. When set, an \overline{IRQ}_2 interrupt is enabled when RDRF and/or ORFE is set; when clear, the interrupt is inhibited. RIE is cleared by RES.

Bit 5 TDRE Transmit Data Register Empty. TDRE is set when the Transmit Data Register is transferred to the output serial shift register or by RES. It is cleared by reading the TRCSR (with TDRE set) and then writing to the Transmit Data Register. Additional data will be transmitted only if TDRE has been cleared.

Bit 6 ORFE Overrun Framing Error. If set, ORFE indicates either an overrun or framing error. An overrun is a new byte ready to transfer to the Receiver Data Register with RDRF still set. A receiver framing error has occurred when the byte boundaries of the bit stream are not synchronized to the bit counter. An overrun can be distinguished from a framing error by the value of RDRF: if RDRF is set, then an overrun has occurred; otherwise a framing error has been detected. Data is not transferred to the Receive Data Register in an overrun or framing error condition. ORFE is cleared by reading the TRCSR (with ORFE set) then the Receive Data Register, or by RES.

Bit 7 RDRF Receive Data Register Full. RDRF is set when the input serial shift register is transferred to the Receive Data Register. It is cleared by reading the TRCSR (with RDRF set), and then the Receive Data Register, or by RES.

Table 6 SCI Bit Times and Rates

SS1	SS0	XTAL	2.4576 MHz	4.0 MHz	4.9152 MHz*
		E	614.4 kHz	1.0 MHz	1.2288 MHz
0	0	E ÷ 16	26 μs/38,400 Baud	16 μs/62,500 Baud	13 μs/76,800 Baud
0	1	E ÷ 128	208 μs/4,800 Baud	128 μs/7812.5 Baud	104.2 μs/9,600 Baud
1	0	E ÷ 1024	1.67ms/600 Baud	1.024ms/976.6 Baud	833.3 μs/1,200 Baud
1	1	E ÷ 4096	6.67ms/150 Baud	4.096ms/244.1 Baud	3.33 ms/300 Baud

* HD68P01V07-1, HD68P01M0-1 only

Table 7 SCI Format and Clock Source Control

CC1:CC0	Format	Clock Source	Port 2 Bit 2	Port 2 Bit 3	Port 2 Bit 4
0 0	—	—	—	—	—
0 1	NRZ	Internal	Not Used	**	**
1 0	NRZ	Internal	Output*	**	**
1 1	NRZ	External	Input	**	**

* Clock output is available regardless of values for bits RE and TE.

** Bit 3 is used for serial input if RE = "1" in TRCS; bit 4 is used for serial output if TE = "1" in TRCS.



● **Internally Generated Clock**

If the user wishes for the serial I/O to furnish a clock, the following requirements are applicable:

- the values of RE and TE are immaterial.
- CC1, CC0 must be set to 10
- the maximum clock rate will be $E \div 16$.
- the clock will be at 1X the bit rate and will have a rising edge at mid-bit.

● **Externally Generated Clock**

If the user wishes to provide an external clock for the serial I/O, the following requirements are applicable:

- the CC1, CC0, field in the Rate and Mode Control Register must be set to 11,
- the external clock must be set to 8 times (X8) the desired baud rate and
- the maximum external clock frequency is 1.0 MHz.

● **Serial Operations**

The SCI is initialized by writing control bytes first to the Rate and Mode Control Register and then to the Transmit/Receive Control and Status Register.

The Transmitter Enable (TE) and Receiver Enable (RE) bits may be left set for dedicated operations.

Transmit operations

The transmit operation is enabled by TE in the Transmit/Receive Control and Status Register. When TE is set, the output of the transmit serial shift register is connected to P₂₄ and the serial output by first transmitting to a ten-bit preamble of 1's. Following the preamble, internal synchronization is established and the transmitter section is ready for operation.

At this point one of two situation exist:

- 1) if the Transmit Data Register is empty (TDRE = 1), a continuous string of ones will be sent indicating an idle line. or,
- 2) if a byte has been written to the Transmit Data Register (TDRE = 0), it is transferred to the output serial shift register and transmission will begin.

During the transfer itself, the start bit (0) is first transmitted.

Then the 8 data bits (beginning with bit 0) followed by the stop bit (1), are transmitted. When the Transmitter Data Register has been emptied, the TDRE flag bit is set.

If the MCU fails to respond to the flag within the proper time, (TDRE is still set when the next normal transfer from the parallel data register to the serial output register should occur) then a 1 will be sent (instead of a 0) at "Start" bit time, followed by more 1's until more data is supplied to the data register. No 0's will be sent while TDRE remains a 1.

Receive Operations

The receive operation is enabled by RE which configures P₂₃. The receive operation is controlled by the contents of the Transmit/Receive Control and Status Register and the Rate and Mode Control Register.

The receiver bit interval is divided into 8 sub-intervals for internal synchronization. In the NRZ Mode, the received bit stream is synchronized by the first 0 (space) encountered.

The approximate center of each bit time is strobed during the next 10 bits. If the tenth bit is not a 1 (stop bit) a framing error is assumed, and ORFE is set. If the tenth bit is a 1, the data is transferred to the Receive Data Register, and interrupt flag RDRF is set. If RDRF is still set at the next tenth bit time, ORFE will be set, indicating an over-run has occurred. When the MCU responds to either flag (RDRF or ORFE) by reading the status register followed by reading the Data Register, RDRF (or ORFE) will be cleared.

■ **INSTRUCTION SET**

The HD68P01 is upward source and object code compatible with the HD6800. Execution times of key instructions have been reduced and several new instructions have been added, including hardware multiply. A list of new operations added to the HD6800 instruction set is shown in Table 8.

In addition, two new special opcodes, 4E and 5E, are provided for test purposes. These opcodes force the Program Counter to increment like a 16-bit counter, causing address lines used in the expanded modes to increment until the device is reset. These opcodes have no mnemonics.

Table 8 New Instructions

Instruction	Description
ABX	Unsigned addition of Accumulator B to Index Register
AADD	Adds (without carry) the double accumulator to memory and leaves the sum in the double accumulator
ASLD	Shifts the double accumulator left (towards MSB) one bit; the LSB is cleared and the MSB is shifted into the C-bit
BRN	Branch Never
LDD	Loads double accumulator from memory
LSRD	Shifts the double accumulator right (towards LSB) one bit; the MSB is cleared and the LSB is shifted into the C-bit
MUL	Unsigned multiply; multiplies the two accumulators and leaves the product in the double accumulator
PSHX	Pushes the Index Register to stack
PULX	Pulls the Index Register from stack
STD	Stores the double accumulator to memory
SUBD	Subtracts memory from the double accumulator and leaves the difference in the double accumulator



● **Programming Model**

A programming model for the HD68P01 is shown in Figure 10. Accumulator A can be concatenated with accumulator B and jointly referred to as accumulator D where A is the most significant byte. Any operation which modifies the double accumulator will also modify accumulator A and/or B. Other registers are defined as follows:

Program Counter

The program counter is a 16-bit register which always points to the next instruction.

Stack Pointer

The stack pointer is a 16-bit register which contains the address of the next available location in a pushdown/pullup (LIFO) queue. The stack resides in random access memory at a location defined by the programmer.

Index Register

The Index Register is a 16-bit register which can be used to store data or provide an address for the indexed mode of addressing.

Accumulators

The CPU contains two 8-bit accumulators, A and B, which are used to store operands and results from the arithmetic logic unit (ALU). They can also be concatenated and referred to as the D (double) accumulator.

Condition Code Registers

The condition code register indicates the results of an instruction and includes the following five condition bits: Negative (N), Zero (Z), Overflow (V), Carry/Borrow from MSB (C), and Half Carry from bit 3 (H). These bits are testable by the conditional branch instruction. Bit 4 is the interrupt mask (I-bit) and inhibits all maskable interrupts when set. The two unused bits, b6 and b7 are read as ones.

● **Addressing Modes**

The CPU provides six addressing modes which can be used to reference memory. A summary of addressing modes for all instructions is presented in Table 9, 10, 11, and 12 where execution times are provided in E-cycles. Instruction execution times are summarized in Table 13. With an input frequency of 4 MHz, E-cycles are equivalent to microseconds. A cycle-by-cycle description of bus activity for each instruction is provided in Table 14 and a description of selected instructions is shown in Figure 26.

Immediate Addressing

The operand or "immediate byte(s)" is contained in the following byte(s) of the instruction where the number of bytes matches the size of the register. These are two or three byte instructions.

Direct Addressing

The least significant byte of the operand address is contained in the second byte of the instruction and the most significant byte is assumed to be \$00. Direct addressing allows the user to access \$00 through \$FF using two byte instructions and execution time is reduced by eliminating the additional memory access. In most applications, the 256-byte area is reserved for frequently referenced data.

Extended Addressing

The second and third bytes of the instruction contain the absolute address of the operand. These are three byte instructions.

Indexed Addressing

The unsigned offset contained in the second byte of the instruction is added with carry to the Index Register and used to reference memory without changing the Index Register. These are two byte instructions.

Table 9 Index Register and Stack Manipulation Instructions

Pointer Operations	Mnemonic	Immed			Direct			Index			Extend			Implied			Boolean/ Arithmetic Operation	Cond. Code Reg.					
		OP	~	#	OP	~	#	OP	~	#	OP	~	#	OP	~	#		H	I	N	Z	V	C
Compare Index Reg	CPX	8C	4	3	9C	5	2	AC	6	2	BC	6	3				X - M; M + 1	•	•	•	•	•	•
Decrement Index Reg	DEX													09	3	1	X - 1 → X	•	•	•	•	•	•
Decrement Stack Pntr	DES													34	3	1	SP - 1 → SP	•	•	•	•	•	•
Increment Index Reg	INX													08	3	1	X + 1 → X	•	•	•	•	•	•
Increment Stack Pntr	INS													31	3	1	SP + 1 → SP	•	•	•	•	•	•
Load Index Reg	LDX	CE	3	3	DE	4	2	EE	5	2	FE	5	3				M → X _H ; (M + 1) → X _L	•	•	•	•	•	R •
Load Stack Pntr	LDS	8E	3	3	9E	4	2	AE	5	2	BE	5	3				M → SP _H ; (M + 1) → SP _L	•	•	•	•	•	R •
Store Index Reg	STX				DF	4	2	EF	5	2	FF	5	3				X _H → M, X _L → (M + 1)	•	•	•	•	•	R •
Store Stack Pntr	STS				9F	4	2	AF	5	2	BF	5	3				SP _H → M, SP _L → (M + 1)	•	•	•	•	•	R •
Index Reg → Stack Pntr	TXS													35	3	1	X - 1 → SP	•	•	•	•	•	•
Stack Pntr → Index Reg	TSX													30	3	1	SP + 1 → X	•	•	•	•	•	•
Add	ABX													3A	3	1	B + X → X	•	•	•	•	•	•
Push Data	PSHX													3C	4	1	X _L → M _{SP} , SP - 1 → SP X _H → M _{SP} , SP - 1 → SP	•	•	•	•	•	•
Pull Data	PULX													38	5	1	SP + 1 → SP, M _{SP} → X _H SP + 1 → SP, M _{SP} → X _L	•	•	•	•	•	•

The Condition Code Register notes are listed after Table 12.



HD68P01V07, HD68P01V07-1, HD68P01M0, HD68P01M0-1

Implied Addressing

The operand(s) are registers and no memory reference is required. These are single byte instructions.

the branch condition is true, the Program Counter is overwritten with the sum of a signed single byte displacement in the second byte of the instruction and the current Program Counter. This provides a branch range of -126 to 129 bytes from the first byte of the instruction. These are two byte instructions.

Relative Addressing

Relative addressing is used only for branch instructions. If

Table 10 Accumulator and Memory Instructions

Accumulator and Memory Operations	Mnemonic	Immed		Direct		Index		Extend		Implied		Boolean Expression	Cond. Code Reg.							
		OP	#	OP	#	OP	#	OP	#	OP	#		H	I	N	Z	V	C		
Add Acmltrs	ABA									1B	2	1	$A + B \rightarrow A$	↑	•	↑	↓	↑	↓	
Add B to X	ABX									3A	3	1	$B + X \rightarrow X$	↑	•	↑	↓	↑	↓	
Add with Carry	ADCA	89	2	2	99	3	2	A9	4	2	B9	4	3	$A + M + C \rightarrow A$	↑	•	↑	↓	↑	↓
	ADCB	C9	2	2	D9	3	2	E9	4	2	F9	4	3	$B + M + C \rightarrow B$	↑	•	↑	↓	↑	↓
Add	ADDA	8B	2	2	9B	3	2	AB	4	2	BB	4	3	$A + M \rightarrow A$	↑	•	↑	↓	↑	↓
	ADDB	CB	2	2	DB	3	2	EB	4	2	FB	4	3	$B + M \rightarrow A$	↑	•	↑	↓	↑	↓
Add Double	ADDD	C3	4	3	D3	5	2	E3	6	2	F3	6	3	$D + M : M + 1 \rightarrow D$	•	•	↑	↓	↑	↓
And	ANDA	84	2	2	94	3	2	A4	4	2	B4	4	3	$A \cdot M \rightarrow A$	•	•	↑	↓	↑	R
	ANDB	C4	2	2	D4	3	2	E4	4	2	F4	4	3	$B \cdot M \rightarrow B$	•	•	↑	↓	↑	R
Shift Left, Arithmetic	ASL							68	6	2	78	6	3		•	•	↑	↓	↑	↓
	ASLA										48	2	1		•	•	↑	↓	↑	↓
	ASLB										58	2	1		•	•	↑	↓	↑	↓
Shift Left Dbl	ASLD										05	3	1		•	•	↑	↓	↑	↓
Shift Right, Arithmetic	ASR							67	6	2	77	6	3		•	•	↑	↓	↑	↓
	ASRA										47	2	1		•	•	↑	↓	↑	↓
	ASRB										57	2	1		•	•	↑	↓	↑	↓
Bit Test	BITA	85	2	2	95	3	2	A5	4	2	B5	4	3	$A \cdot M$	•	•	↑	↓	↑	R
	BITB	C5	2	2	D5	3	2	E5	4	2	F5	4	3	$B \cdot M$	•	•	↑	↓	↑	R
Compare Acmltrs	CBA										11	2	1	$A - B$	•	•	↑	↓	↑	↓
Clear	CLR							6F	6	2	7F	6	3	$00 \rightarrow M$	•	•	R	S	R	R
	CLRA										4F	2	1	$00 \rightarrow A$	•	•	R	S	R	R
	CLRB										5F	2	1	$00 \rightarrow B$	•	•	R	S	R	R
Compare	CMPA	81	2	2	91	3	2	A1	4	2	B1	4	3	$A - M$	•	•	↑	↓	↑	↓
	CMPB	C1	2	2	D1	3	2	E1	4	2	F1	4	3	$B - M$	•	•	↑	↓	↑	↓
1's Complement	COM							63	6	2	73	6	3	$\bar{M} \rightarrow M$	•	•	↑	↓	↑	R
	COMA										43	2	1	$\bar{A} \rightarrow A$	•	•	↑	↓	↑	R
	COMB										53	2	1	$\bar{B} \rightarrow B$	•	•	↑	↓	↑	R
Decimal Adj, A	DAA										19	2	1	Adj. binary sum to BCD	•	•	↑	↓	↑	↓
Decrement	DEC							6A	6	2	7A	6	3	$M - 1 \rightarrow M$	•	•	↑	↓	↑	•
	DECA										4A	2	1	$A - 1 \rightarrow A$	•	•	↑	↓	↑	•
	DECB										5A	2	1	$B - 1 \rightarrow B$	•	•	↑	↓	↑	•
Exclusive OR	EORA	88	2	2	98	3	2	A8	4	2	B8	4	3	$A \oplus M \rightarrow A$	•	•	↑	↓	↑	R
	EORB	C8	2	2	D8	3	2	E8	4	2	F8	4	3	$B \oplus M \rightarrow B$	•	•	↑	↓	↑	R
Increment	INC							6C	6	2	7C	6	3	$M + 1 \rightarrow M$	•	•	↑	↓	↑	•
	INCA										4C	2	1	$A + 1 \rightarrow A$	•	•	↑	↓	↑	•
	INCB										5C	2	1	$B + 1 \rightarrow B$	•	•	↑	↓	↑	•
Load Acmltrs	LDAA	86	2	2	96	3	2	A6	4	2	B6	4	3	$M \rightarrow A$	•	•	↑	↓	↑	R
	LDAB	C6	2	2	D6	3	2	E6	4	2	F6	4	3	$M \rightarrow B$	•	•	↑	↓	↑	R
Load Double	LDD	CC	3	3	DC	4	2	EC	5	2	FC	5	3	$M : M + 1 \rightarrow D$	•	•	↑	↓	↑	R
Logical Shift, Left	LSL							68	6	2	78	6	3		•	•	↑	↓	↑	↓
	LSLA										48	2	1		•	•	↑	↓	↑	↓
	LSLB										58	2	1		•	•	↑	↓	↑	↓
	LSLD										05	3	1		•	•	↑	↓	↑	↓
Shift Right, Logical	LSR							64	6	2	74	6	3		•	•	R	↑	↓	↓
	LSRA										44	2	1		•	•	R	↑	↓	↓
	LSRB										54	2	1		•	•	R	↑	↓	↓
	LSRD										04	3	1		•	•	R	↑	↓	↓

(Continued)



Table 10 Accumulator and Memory Instructions (Continued)

Accumulator and Memory Operations	Mnemonic	Immed			Direct			Index			Extend			Implied			Boolean Expression	Cond. Code Reg.							
		OP	~	#	OP	~	#	OP	~	#	OP	~	#	OP	~	#		H	I	N	Z	V	C		
Multiply	MUL														3D 10 1	A X B → D	•	•	•	•	•	•			
2's Complement (Negate)	NEG							60	6	2	70	6	3				00 - M → M	•	•	↑	↑	↑	↑		
	NEGA													40	2	1	00 - A → A	•	•	↑	↑	↑	↑		
	NEGB													50	2	1	00 - B → B	•	•	↑	↑	↑	↑		
No Operation	NOP													01	2	1	PC + 1 → PC	•	•	•	•	•	•		
Inclusive OR	ORAA	8A	2	2	9A	3	2	AA	4	2	BA	4	3				A + M → A	•	•	↑	↑	↑	•		
	ORAB	CA	2	2	DA	3	2	EA	4	2	FA	4	3				B + M → B	•	•	↑	↑	↑	R •		
Push Data	PSHA													36	3	1	A → Stack	•	•	•	•	•	•		
	PSHB													37	3	1	B → Stack	•	•	•	•	•	•		
Pull Data	PULA													32	4	1	Stack → A	•	•	•	•	•	•		
	PULB													33	4	1	Stack → B	•	•	•	•	•	•		
Rotate Left	ROL							69	6	2	79	6	3					•	•	↑	↑	↑	↑		
	ROLA													49	2	1		•	•	↑	↑	↑	↑		
	ROLB													59	2	1		•	•	↑	↑	↑	↑		
Rotate Right	ROR							66	6	2	76	6	3					•	•	↑	↑	↑	↑		
	RORA													46	2	1		•	•	↑	↑	↑	↑		
	RORB													56	2	1		•	•	↑	↑	↑	↑		
Subtract Acmltr	SBA													10	2	1	A - B → A	•	•	↑	↑	↑	↑		
Subtract with Carry	SBCA	82	2	2	92	3	2	A2	4	2	B2	4	3				A - M - C → A	•	•	↑	↑	↑	↑		
	SBCB	C2	2	2	D2	3	2	E2	4	2	F2	4	3				B - M - C → B	•	•	↑	↑	↑	↑		
Store Acmltrs	STAA						97	3	2	A7	4	2	B7	4	3				A → M	•	•	↑	↑	R	•
	STAB						D7	3	2	E7	4	2	F7	4	3				B → M	•	•	↑	↑	R	•
	STD						DD	4	2	ED	5	2	FD	5	3				D → M: M + 1	•	•	↑	↑	R	•
Subtract	SUBA	80	2	2	90	3	2	A0	4	2	B0	4	3				A - M → A	•	•	↑	↑	↑	↑		
	SUBB	C0	2	2	D0	3	2	E0	4	2	F0	4	3				B - M → B	•	•	↑	↑	↑	↑		
Subtract Double	SUBD	83	4	3	93	5	2	A3	6	2	B3	6	3				D - M: M + 1 → D	•	•	↑	↑	↑	↑		
Transfer Acmltr	TAB													16	2	1	A → B	•	•	↑	↑	R	•		
	TBA													17	2	1	B → A	•	•	↑	↑	R	•		
Test, Zero or Minus	TST							6D	6	2	7D	6	3				M - 00	•	•	↑	↑	R	R		
	TSTA													4D	2	1	A - 00	•	•	↑	↑	R	R		
	TSTB													5D	2	1	B - 00	•	•	↑	↑	R	R		

The Condition Code Register notes are listed after Table 12.



Table 11 Jump and Branch Instructions

Operations	Mnemonic	Direct			Relative			Index			Extend			Implied			Branch Test	Cond. Code Reg.					
		OP	~	#	OP	~	#	OP	~	#	OP	~	#	OP	~	#		5	4	3	2	1	0
																		H	I	N	Z	V	C
Branch Always	BRA				20	3	2										None	•	•	•	•	•	•
Branch Never	BRN				21	3	2										None	•	•	•	•	•	•
Branch If Carry Clear	BCC				24	3	2										C = 0	•	•	•	•	•	•
Branch If Carry Set	BCS				25	3	2										C = 1	•	•	•	•	•	•
Branch If = Zero	BEQ				27	3	2										Z = 1	•	•	•	•	•	•
Branch If ≥ Zero	BGE				2C	3	2										$N \oplus V = 0$	•	•	•	•	•	•
Branch If > Zero	BGT				2E	3	2										$Z + (N \oplus V) = 0$	•	•	•	•	•	•
Branch If Higher	BHI				22	3	2										$C + Z = 0$	•	•	•	•	•	•
Branch If Higher or Same	BHS				24	3	2										C = 0	•	•	•	•	•	•
Branch If ≤ Zero	BLE				2F	3	2										$Z + (N \oplus V) = 1$	•	•	•	•	•	•
Branch If Carry Set	BLO				25	3	2										C = 1	•	•	•	•	•	•
Branch If Lower Or Same	BLS				23	3	2										$C + Z = 1$	•	•	•	•	•	•
Branch If < Zero	BLT				2D	3	2										$N \oplus V = 1$	•	•	•	•	•	•
Branch If Minus	BMI				2B	3	2										N = 1	•	•	•	•	•	•
Branch If Not Equal Zero	BNE				26	3	2										N = 0	•	•	•	•	•	•
Branch If Overflow Clear	BVC				28	3	2										V = 0	•	•	•	•	•	•
Branch If Overflow Set	BVS				29	3	2										V = 1	•	•	•	•	•	•
Branch If Plus	BPL				2A	3	2										N = 0	•	•	•	•	•	•
Branch To Subroutine	BSR				8D	6	2											•	•	•	•	•	•
Jump	JMP							6E	3	2	7E	3	3					•	•	•	•	•	•
Jump To Subroutine	JSR	9D	5	2				AD	6	2	BD	6	3					•	•	•	•	•	•
No Operation	NOP													01	2	1		•	•	•	•	•	•
Return From Interrupt	RTI													3B	10	1		↑	↑	↑	↑	↑	↑
Return From Subroutine	RTS													39	5	1		•	•	•	•	•	•
Software Interrupt	SWI													3F	12	1		•	S	•	•	•	•
Wait For Interrupt	WAI													3E	9	1		•	•	•	•	•	•

The Condition Code Register notes are listed after Table 12.

Table 12 Condition Code Register Manipulation Instructions

Operations	Implied			Boolean Operation	Cond. Code Reg.						
	Mnemonic	OP	~		#	5	4	3	2	1	0
						H	I	N	Z	V	C
Clear Carry	CLC	0C	2	1	0 → C	•	•	•	•	•	R
Clear Interrupt Mask	CLI	0E	2	1	0 → I	•	R	•	•	•	•
Clear Overflow	CLV	0A	2	1	0 → V	•	•	•	•	R	•
Set Carry	SEC	0D	2	1	1 → C	•	•	•	•	•	S
Set Interrupt Mask	SEI	0F	2	1	1 → I	•	S	•	•	•	•
Set Overflow	SEV	0B	2	1	1 → V	•	•	•	•	S	•
Accumulator A → CCR	TAP	06	2	1	A → CCR	↑	↑	↑	↑	↑	↑
CCR → Accumulator A	TPA	07	2	1	CCR → A	•	•	•	•	•	•

LEGEND

- OP Operation Code (Hexadecimal)
- ~ Number of MPU Cycles
- Msp Contents of memory location pointed to by Stack Pointer
- # Number of Program Bytes
- + Arithmetic Plus
- Arithmetic Minus
- Boolean AND
- X Arithmetic Multiply
- + Boolean Inclusive OR
- ⊕ Boolean Exclusive OR
- M Complement of M
- Transfer Into
- 0 Bit = Zero
- 00 Byte = Zero

CONDITION CODE SYMBOLS

- H Half-carry from bit 3
- I Interrupt mask
- N Negative (sign bit)
- Z Zero (byte)
- V Overflow, 2's complement
- C Carry/Borrow from MSB
- R Reset Always
- S Set Always
- ↑ Affected
- Not Affected



Table 13 Instruction Execution Times in E-Cycles

	Addressing Mode					
	Immediate	Direct	Extended	Indexed	Implied	Relative
ABA	•	•	•	•	2	•
ABX	•	•	•	•	3	•
ADC	2	3	4	4	•	•
ADD	2	3	4	4	•	•
ADDD	4	5	6	6	•	•
AND	2	3	4	4	•	•
ASL	•	•	6	6	•	•
ASLD	•	•	•	•	3	•
ASR	•	•	6	6	•	•
BCC	•	•	•	•	•	3
BCS	•	•	•	•	•	3
BEQ	•	•	•	•	•	3
BGE	•	•	•	•	•	3
BGT	•	•	•	•	•	3
BHI	•	•	•	•	•	3
BHS	•	•	•	•	•	3
BIT	2	3	4	4	•	•
BLE	•	•	•	•	•	3
BLO	•	•	•	•	•	3
BLS	•	•	•	•	•	3
BLT	•	•	•	•	•	3
BMI	•	•	•	•	•	3
BNE	•	•	•	•	•	3
BPL	•	•	•	•	•	3
BRA	•	•	•	•	•	3
BRN	•	•	•	•	•	3
BSR	•	•	•	•	•	6
BVC	•	•	•	•	•	3
BVS	•	•	•	•	•	3
CBA	•	•	•	•	2	•
CLC	•	•	•	•	2	•
CLI	•	•	•	•	2	•
CLR	•	•	6	6	•	•
CLV	•	•	•	•	2	•
CMP	2	3	4	4	•	•
COM	•	•	6	6	2	•
CPX	4	5	6	6	•	•
DAA	•	•	•	•	2	•
DEC	•	•	6	6	•	•
DES	•	•	•	•	3	•
DEX	•	•	•	•	3	•
EOR	2	3	4	4	•	•
INC	•	•	6	6	•	•
INS	•	•	•	•	3	•

	Addressing Mode					
	Immediate	Direct	Extended	Indexed	Implied	Relative
INX	•	•	•	•	3	•
JMP	•	•	3	3	•	•
JSR	•	5	6	6	•	•
LDA	2	3	4	4	•	•
LDD	3	4	5	5	•	•
LDS	3	4	5	5	•	•
LDX	3	4	5	5	•	•
LSR	•	•	6	6	•	•
LSRD	•	•	•	•	3	•
MUL	•	•	•	•	10	•
NEG	•	•	6	6	•	•
NOP	•	•	•	•	2	•
ORA	2	3	4	4	•	•
PSH	•	•	•	•	•	•
PSHX	•	•	•	•	4	•
PUL	•	•	•	•	•	•
PULX	•	•	•	•	5	•
ROL	•	•	6	6	•	•
ROR	•	•	6	6	•	•
RTI	•	•	•	•	10	•
RTS	•	•	•	•	5	•
SBA	•	•	•	•	2	•
SBC	2	3	4	4	•	•
SEC	•	•	•	•	2	•
SEI	•	•	•	•	2	•
SEV	•	•	•	•	2	•
STA	•	3	4	4	•	•
STD	•	4	5	5	•	•
STS	•	4	5	5	•	•
STX	•	4	5	5	•	•
SUB	2	3	4	4	•	•
SUBD	4	5	6	6	•	•
SWI	•	•	•	•	12	•
TAB	•	•	•	•	2	•
TAP	•	•	•	•	2	•
TBA	•	•	•	•	2	•
TBA	•	•	•	•	2	•
TPA	•	•	•	•	2	•
TST	•	•	6	6	•	•
TSX	•	•	•	•	3	•
TXS	•	•	•	•	3	•
WAI	•	•	•	•	9	•



■ SUMMARY OF CYCLE BY CYCLE OPERATION

Table 14 provides a detailed description of the information present on the Address Bus, Data Bus, and the Read/Write (R/W) line during each cycle of each instruction.

The information is useful in comparing actual with expected results during debug to both software and hardware as the program is executed. The information is categorized in groups according to addressing mode and number of cycles per instruction.

In general, instructions with the same addressing mode and number of cycles execute in the same manner. Exceptions are indicated in the table.

Note that during MCU reads of internal locations, the resultant value will not appear on the external Data Bus except in Mode 0. "High order" byte refers to the most significant byte of a 16-bit value.

Table 14 Cycle by Cycle Operation

Address Mode & Instructions	Cycles	Cycle #	Address Bus	R/W Line	Data Bus	
IMMEDIATE						
ADC EOR	2	1	Op Code Address	1	Op Code	
ADD LDA		2	Op Code Address + 1	1	Operand Data	
AND ORA						
BIT SBC						
CMP SUB						
LDS	3	1	Op Code Address	1	Op Code	
LDX		2	Op Code Address + 1	1	Operand Data (High Order Byte)	
LDD		3	Op Code Address + 2	1	Operand Data (Low Order Byte)	
CPX	4	1	Op Code Address	1	Op Code	
SUBD		2	Op Code Address + 1	1	Operand Data (High Order Byte)	
ADDD		3	Op Code Address + 2	1	Operand Data (Low Order Byte)	
		4	Address Bus FFFF	1	Low Byte of Restart Vector	
DIRECT						
ADC EOR	3	1	Op Code Address	1	Op Code	
ADD LDA		2	Op Code Address + 1	1	Address of Operand	
AND ORA		3	Address of Operand	1	Operand Data	
BIT SBC						
CMP SUB						
STA	3	1	Op Code Address	1	Op Code	
		2	Op Code Address + 1	1	Destination Address	
		3	Destination Address	0	Data from Accumulator	
LDS	4	1	Op Code Address	1	Op Code	
LDX		2	Op Code Address + 1	1	Address of Operand	
LDD		3	Address of Operand	1	Operand Data (High Order Byte)	
		4	Operand Address + 1	1	Operand Data (Low Order Byte)	
STS	4	1	Op Code Address	1	Op Code	
STX		2	Op Code Address + 1	1	Address of Operand	
STD		3	Address of Operand	0	Register Data (High Order Byte)	
		4	Address of Operand + 1	0	Register Data (Low Order Byte)	
CPX	5	1	Op Code Address	1	Op Code	
SUBD		2	Op Code Address + 1	1	Address of Operand	
ADDD		3	Operand Address	1	Operand Data (High Order Byte)	
		4	Operand Address + 1	1	Operand Data (Low Order Byte)	
		5	Address Bus FFFF	1	Low Byte of Restart Vector	
JSR	5	1	Op Code Address	1	Op Code	
		2	Op Code Address + 1	1	Irrelevant Data	
		3	Subroutine Address	1	First Subroutine Op Code	
		4	Stack Pointer	0	Return Address (Low Order Byte)	
		5	Stack Pointer + 1	0	Return Address (High Order Byte)	

(Continued)



HD68P01V07, HD68P01V07-1, HD68P01M0, HD68P01M0-1

Table 14 Cycle by Cycle Operation (Continued)

Address Mode & Instructions	Cycles	Cycle #	Address Bus	R/W Line	Data Bus
EXTENDED					
JMP	3	1	Op Code Address	1	Op Code
		2	Op Code Address + 1	1	Jump Address (High Order Byte)
		3	Op Code Address + 2	1	Jump Address (Low Order Byte)
ADC EOR ADD LDA AND ORA BIT SBC CMP SUB	4	1	Op Code Address	1	Op Code
		2	Op Code Address + 1	1	Address of Operand (High Order Byte)
		3	Op Code Address + 2	1	Address of Operand (Low Order Byte)
		4	Address of Operand	1	Operand Data
STA	4	1	Op Code Address	1	Op Code
		2	Op Code Address + 1	1	Destination Address (High Order Byte)
		3	Op Code Address + 2	1	Destination Address (Low Order Byte)
		4	Operand Destination Address	0	Data from Accumulator
LDS LDX LDD	5	1	Op Code Address	1	Op Code
		2	Op Code Address + 1	1	Address of Operand (High Order Byte)
		3	Op Code Address + 2	1	Address of Operand (Low Order Byte)
		4	Address of Operand	1	Operand Data (High Order Byte)
		5	Address of Operand + 1	1	Operand Data (Low Order Byte)
STS STX STD	5	1	Op Code Address	1	Op Code
		2	Op Code Address + 1	1	Address of Operand (High Order Byte)
		3	Op Code Address + 2	1	Address of Operand (Low Order Byte)
		4	Address of Operand	0	Operand Data (High Order Byte)
		5	Address of Operand + 1	0	Operand Data (Low Order Byte)
ASL LSR ASR NEG CLR ROL COM ROR DEC TST* INC	6	1	Op Code Address	1	Op Code
		2	Op Code Address + 1	1	Address of Operand (High Order Byte)
		3	Op Code Address + 2	1	Address of Operand (Low Order Byte)
		4	Address of Operand	1	Current Operand Data
		5	Address Bus FFFF	1	Low Byte of Restart Vector
		6	Address of Operand	0	New Operand Data
CPX SUBD ADDD	6	1	Op Code Address	1	Op Code
		2	Op Code Address + 1	1	Operand Address (High Order Byte)
		3	Op Code Address + 2	1	Operand Address (Low Order Byte)
		4	Operand Address	1	Operand Data (High Order Byte)
		5	Operand Address + 1	1	Operand Data (Low Order Byte)
		6	Address Bus FFFF	1	Low Byte of Restart Vector
JSR	6	1	Op Code Address	1	Op Code
		2	Op Code Address + 1	1	Address of Subroutine (High Order Byte)
		3	Op Code Address + 2	1	Address of Subroutine (Low Order Byte)
		4	Subroutine Starting Address	1	Op Code of Next Instruction
		5	Stack Pointer	0	Return Address (Low Order Byte)
		6	Stack Pointer - 1	0	Return Address (High Order Byte)

* In the TST instruction, the line condition of the sixth cycle does the following: R/W = "High", AB = FFFF, DB = Low Byte of Reset Vector.

(Continued)



Table 14 Cycle by Cycle Operation (Continued)

Address Mode & Instructions	Cycles	Cycle #	Address Bus	R/W Line	Data Bus
INDEXED					
JMP	3	1	Op Code Address	1	Op Code
		2	Op Code Address + 1	1	Offset
		3	Address Bus FFFF	1	Low Byte of Restart Vector
ADC EOR ADD LDA AND ORA BIT SBC CMP SUB	4	1	Op Code Address	1	Op Code
		2	Op Code Address + 1	1	Offset
		3	Address Bus FFFF	1	Low Byte of Restart Vector
		4	Index Register Plus Offset	1	Operand Data
STA	4	1	Op Code Address	1	Op Code
		2	Op Code Address + 1	1	Offset
		3	Address Bus FFFF	1	Low Byte of Restart Vector
		4	Index Register Plus Offset	0	Operand Data
LDS LDX LDD	5	1	Op Code Address	1	Op Code
		2	Op Code Address + 1	1	Offset
		3	Address Bus FFFF	1	Low Byte of Restart Vector
		4	Index Register Plus Offset	1	Operand Data (High Order Byte)
		5	Index Register Plus Offset + 1	1	Operand Data (Low Order Byte)
STS STX STD	5	1	Op Code Address	1	Op Code
		2	Op Code Address + 1	1	Offset
		3	Address Bus FFFF	1	Low Byte of Restart Vector
		4	Index Register Plus Offset	0	Operand Data (High Order Byte)
		5	Index Register Plus Offset + 1	0	Operand Data (Low Order Byte)
ASL LSR ASR NEG CLR ROL COM ROR DEC TST * INC	6	1	Op Code Address	1	Op Code
		2	Op Code Address + 1	1	Offset
		3	Address Bus FFFF	1	Low Byte of Restart Vector
		4	Index Register Plus Offset	1	Current Operand Data
		5	Address Bus FFFF	1	Low Byte of Restart Vector
		6	Index Register Plus Offset	0	New Operand Data
CPX SUBD ADD	6	1	Op Code Address	1	Op Code
		2	Op Code Address + 1	1	Offset
		3	Address Bus FFFF	1	Low Byte of Restart Vector
		4	Index Register + Offset	1	Operand Data (High Order Byte)
		5	Index Register + Offset + 1	1	Operand Data (Low Order Byte)
		6	Address Bus FFFF	1	Low Byte of Restart Vector
JSR	6	1	Op Code Address	1	Op Code
		2	Op Code Address + 1	1	Offset
		3	Address Bus FFFF	1	Low Byte of Restart Vector
		4	Index Register + Offset	1	First Subroutine Op Code
		5	Stack Pointer	0	Return Address (Low Order Byte)
		6	Stack Pointer - 1	0	Return Address (High Order Byte)

* In the TST instruction, the line condition of the sixth cycle does the following: R/W = "High", AB = FFFF, DB = Low Byte of Restart Vector.

(Continued)



Table 14 Cycle by Cycle Operation (Continued)

Address Mode & Instructions	Cycles	Cycle #	Address Bus	R/W Line	Data Bus	
IMPLIED						
ABA DAA SEC ASL DEC SEI ASR INC SEV CBA LSR TAB CLC NEG TAP CLI NOP TBA CLR ROL TPA CLV ROR TST COM SBA	2	1	Op Code Address	1	Op Code	
		2	Op Code Address + 1	1	Op Code of Next Instruction	
ABX	3	1	Op Code Address	1	Op Code	
		2	Op Code Address + 1	1	Irrelevant Data	
		3	Address Bus FFFF	1	Low Byte of Restart Vector	
ASLD LSRD	3	1	Op Code Address	1	Op Code	
		2	Op Code Address + 1	1	Irrelevant Data	
		3	Address Bus FFFF	1	Low Byte of Restart Vector	
DES INS	3	1	Op Code Address	1	Op Code	
		2	Op Code Address + 1	1	Op Code of Next Instruction	
		3	Previous Register Contents	1	Irrelevant Data	
INX DEX	3	1	Op Code Address	1	Op Code	
		2	Op Code Address + 1	1	Op Code of Next Instruction	
		3	Address Bus FFFF	1	Low Byte of Restart Vector	
PSHA PSHB	3	1	Op Code Address	1	Op Code	
		2	Op Code Address + 1	1	Op Code of Next Instruction	
		3	Stack Pointer	0	Accumulator Data	
TSX	3	1	Op Code Address	1	Op Code	
		2	Op Code Address + 1	1	Op Code of Next Instruction	
		3	Stack Pointer	1	Irrelevant Data	
TXS	3	1	Op Code Address	1	Op Code	
		2	Op Code Address + 1	1	Op Code of Next Instruction	
		3	Address Bus FFFF	1	Low Byte of Restart Vector	
PULA PULB	4	1	Op Code Address	1	Op Code	
		2	Op Code Address + 1	1	Op Code of Next Instruction	
		3	Stack Pointer	1	Irrelevant Data	
		4	Stack Pointer + 1	1	Operand Data from Stack	
PSHX	4	1	Op Code Address	1	Op Code	
		2	Op Code Address + 1	1	Irrelevant Data	
		3	Stack Pointer	0	Index Register (Low Order Byte)	
		4	Stack Pointer + 1	0	Index Register (High Order Byte)	
PULX	5	1	Op Code Address	1	Op Code	
		2	Op Code Address + 1	1	Irrelevant Data	
		3	Stack Pointer	1	Irrelevant Data	
		4	Stack Pointer + 1	1	Index Register (High Order Byte)	
		5	Stack Pointer + 2	1	Index Register (Low Order Byte)	
RTS	5	1	Op Code Address	1	Op Code	
		2	Op Code Address + 1	1	Irrelevant Data	
		3	Stack Pointer	1	Irrelevant Data	
		4	Stack Pointer + 1	1	Address of Next Instruction (High Order Byte)	
		5	Stack Pointer + 2	1	Address of Next Instruction (Low Order Byte)	

(Continued)



Table 14 Cycle by Cycle Operation (Continued)

Address Mode & Instruction	Cycles	Cycle #	Address Bus	R/W Line	Data Bus
WAI **	9	1	Op Code Address	1	Op Code
		2	Op Code Address + 1	1	Op Code of Next Instruction
		3	Stack Pointer	0	Return Address (Low Order Byte)
		4	Stack Pointer - 1	0	Return Address (High Order Byte)
		5	Stack Pointer - 2	0	Index Register (Low Order Byte)
		6	Stack Pointer - 3	0	Index Register (High Order Byte)
		7	Stack Pointer - 4	0	Contents of Accumulator A
		8	Stack Pointer - 5	0	Contents of Accumulator B
		9	Stack Pointer - 6	0	Contents of Cond. Code Register
MUL	10	1	Op Code Address	1	Op Code
		2	Op Code Address + 1	1	Irrelevant Data
		3	Address Bus FFFF	1	Low Byte of Restart Vector
		4	Address Bus FFFF	1	Low Byte of Restart Vector
		5	Address Bus FFFF	1	Low Byte of Restart Vector
		6	Address Bus FFFF	1	Low Byte of Restart Vector
		7	Address Bus FFFF	1	Low Byte of Restart Vector
		8	Address Bus FFFF	1	Low Byte of Restart Vector
		9	Address Bus FFFF	1	Low Byte of Restart Vector
		10	Address Bus FFFF	1	Low Byte of Restart Vector
RTI	10	1	Op Code Address	1	Op Code
		2	Op Code Address + 1	1	Irrelevant Data
		3	Stack Pointer	1	Irrelevant Data
		4	Stack Pointer + 1	1	Contents of Cond. Code Reg. from Stack
		5	Stack Pointer + 2	1	Contents of Accumulator B from Stack
		6	Stack Pointer + 3	1	Contents of Accumulator A from Stack
		7	Stack Pointer + 4	1	Index Register from Stack (High Order Byte)
		8	Stack Pointer + 5	1	Index Register from Stack (Low Order Byte)
		9	Stack Pointer + 6	1	Next Instruction Address from Stack (High Order Byte)
		10	Stack Pointer + 7	1	Next Instruction Address from Stack (Low Order Byte)
SWI	12	1	Op Code Address	1	Op Code
		2	Op Code Address + 1	1	Irrelevant Data
		3	Stack Pointer	0	Return Address (Low Order Byte)
		4	Stack Pointer - 1	0	Return Address (High Order Byte)
		5	Stack Pointer - 2	0	Index Register (Low Order Byte)
		6	Stack Pointer - 3	0	Index Register (High Order Byte)
		7	Stack Pointer - 4	0	Contents of Accumulator A
		8	Stack Pointer - 5	0	Contents of Accumulator B
		9	Stack Pointer - 6	0	Contents of Cond. Code Register
		10	Stack Pointer - 7	1	Irrelevant Data
		11	Vector Address FFFA (Hex)	1	Address of Subroutine (High Order Byte)
		12	Vector Address FFFB (Hex)	1	Address of Subroutine (Low Order Byte)

** While the MCU is in the 'Wait' state, its bus state will appear as a series of the MCU reads of an address which is seven locations less than the original contents of the Stack Pointer. Contrary to the HD6800, none of the ports are driven to the high impedance state by a WAI instruction.

(Continued)



Table 14 Cycle by Cycle Operation (Continued)

Address Mode & Instruction	Cycles	Cycle #	Address Bus	R/W Line	Data Bus
RELATIVE					
BCC BHT BNE	3	1	Op Code Address	1	Op Code
BCS BLE BPL		2	Op Code Address + 1	1	Branch Offset
BEQ BLS BRA BRN		3	Address Bus FFFF	1	Low Byte of Restart Vector
BGE BLT BVC	6	1	Op Code Address	1	Op Code
BGT BMT BVS		2	Op Code Address + 1	1	Branch Offset
BSR		3	Address Bus FFFF	1	Low Byte of Restart Vector
		4	Subroutine Starting Address	1	Op Code of Next Instruction
		5	Stack Pointer	0	Return Address (Low Order Byte)
		6	Stack Pointer - 1	0	Return Address (High Order Byte)

■ SUMMARY OF UNDEFINED INSTRUCTIONS OPERATION

The MCU has 36 undefined instructions. When these are carried out, the contents of Register and Memory in MCU change at random.

When the op codes (4E, 5E) are used to execute, the MCU continues to increase the program counter and it will not stop until the Reset signal enters. These op codes are used to test the LSI.

Table 15 Op Codes Map

HD68P01 MICROCOMPUTER INSTRUCTIONS																		
OP CODE		ACC A								ACCA or SP				ACCB or X				
		0000	0001	0010	0011	0100	0101	0110	0111	IMM	DIR	IND	EXT	IMM	DIR	IND	EXT	
LO	HI	0	1	2	3	4	5	6	7	B	9	A	B	C	D	E	F	
0000	0		SBA	BRA	TSX	NEG				SUB								0
0001	1	NOB	CBA	BRN	INS					CMP								1
0010	2		BHI	PULA (+1)					SBC								2	
0011	3		BLS	PULB (+1)	COM				* SUBD (+2) *				* ADDD (+2) *				3	
0100	4	LSRD (+1)		BCC	DES	LSR				AND								4
0101	5	ASLD (+1)		BCS	TXS					BIT								5
0110	6	TAP	TAB	BNE	PSHA	ROR				LDA								6
0111	7	TPA	TBA	BEQ	PSHB	ASR				STA				STA				7
1000	8	INX (+1)		BVC	PULX (+2)	ASL				EOR								8
1001	9	DEX (+1)	DAA	BVS	RTS (+2)	ROL				ADC								9
1010	A	CLV		BPL	ABX	DEC				ORA								A
1011	B	SEV	ABA	BMI	RTI (+7)					ADD								B
1100	C	CLC		BGE	PSHX (+1)	INC				* CPX (+2) *				* LDD (+1) *				C
1101	D	SEC		BLT	MUL (+7)	TST				BSR (+4)				* (+1) STD (+1) *				D
1110	E	CLI		BGT	WAI (+6)	** JMP (-3) *				* LDS (+1) *				* LDX (+1) *				E
1111	F	SEI		BLE	SWI (+9)	CLR				* (+1) STS (+1) *				* (+1) STX (+1) *				F
BYTE/CYCLE		1/2	1/2	2/3	1/3	1/2	1/2	2/6	3/6	2/2	2/3	2/4	3/4	2/2	2/3	2/4	3/4	

- (NOTES) 1. Undefined Op codes are marked with
 2. () indicate that the number in parenthesis must be added to the cycle count for that instruction.
 3. The instructions shown below are all 3 bytes and are marked with "**". Immediate addressing mode of SUBD, CPX, LDS, ADDD, LDD and LDX instructions, and undefined op codes (8F, CD, CF).
 4. The Op codes (4E, 5E) are 1 byte/∞ cycles instructions, and are marked with "****".



HD68P01V07, HD68P01V07-1, HD68P01M0, HD68P01M0-1

■ PRECAUTIONS WHEN EMULATING THE HD6801 FAMILY

The HD68P01 series has 8k-byte EPROM space internally in location \$E000 to \$FFFF. Note the following when emulating the HD6801S0 (2k-byte ROM on-chip) and the HD6801V0 (4k-byte ROM on-chip) with the HD68P01 series.

1) Mode 0, 1, 6

Table 16 shows the address which may be used for the internal ROM space.

Table 16

HD6801S0	\$F800 to \$FFFF (2k bytes)
HD6801V0	\$F000 to \$FFFF (4k bytes)

Mode 0, 1 and 6 are expanded modes. When emulating the HD6801S0 and the HD6801V0, the addresses shown in Table 17 should not be used externally because they are the internal space in the EPROM on the package type. (See Fig. 26)

Table 17

HD6801S0	\$E000 to \$F7FF (6k bytes)
HD6801V0	\$E000 to \$EFFF (4k bytes)

(Example)

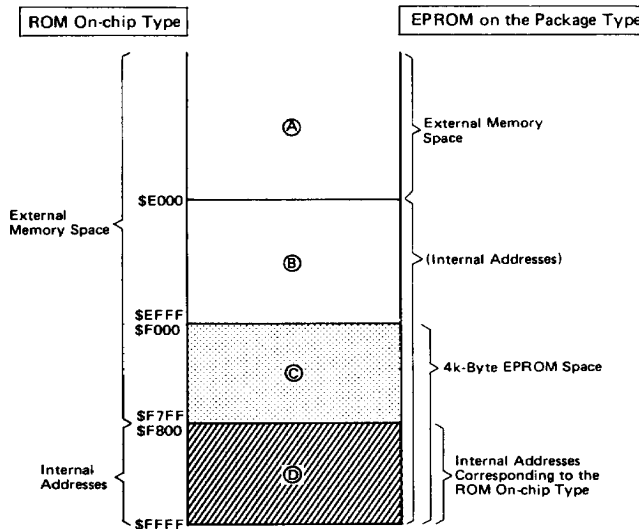

Figure 26 Memory Map Example when Emulating the HD6801S0 with the HD68P01M0 and the 4k-Byte EPROM

Figure 26 shows an address map example when emulating the HD6801S0 with the HD68P01M0 and the 4k-byte EPROM in mode 0, 1 and 6. In the emulation of expanded modes, the addresses for memories and peripherals may be used externally in space A, but not in space B and C which are internal ad-

(Note 1) In Table 16, the following addresses are external like the ROM on-chip type:
\$FFF0 to \$FFFF in Mode 1
\$FFFE and \$FFFF (reset vector) just after releasing reset in Mode 0

(Note 2) In Mode 0, data will not appear at Port 3 if accessing the EPROM addresses. It is different from the ROM on-chip type.

2) Mode 5, 7

Table 18 shows the addresses which may be used for the internal ROM space without any limitations.

Table 18

HD6801S0	\$F800 to \$FFFF (2k bytes)
HD6801V0	\$F000 to \$FFFF (4k bytes)

3) Mode 2, 3, 4

In these modes, the internal ROM is disable. The EPROM on the package type may be used equivalently as the ROM on-chip type.

resses in the EPROM on the package type.

Figure 27 and 28 show the memory maps when emulating the HD6801S0 and HD6801V0 with the EPROM on the package type and the EPROM.



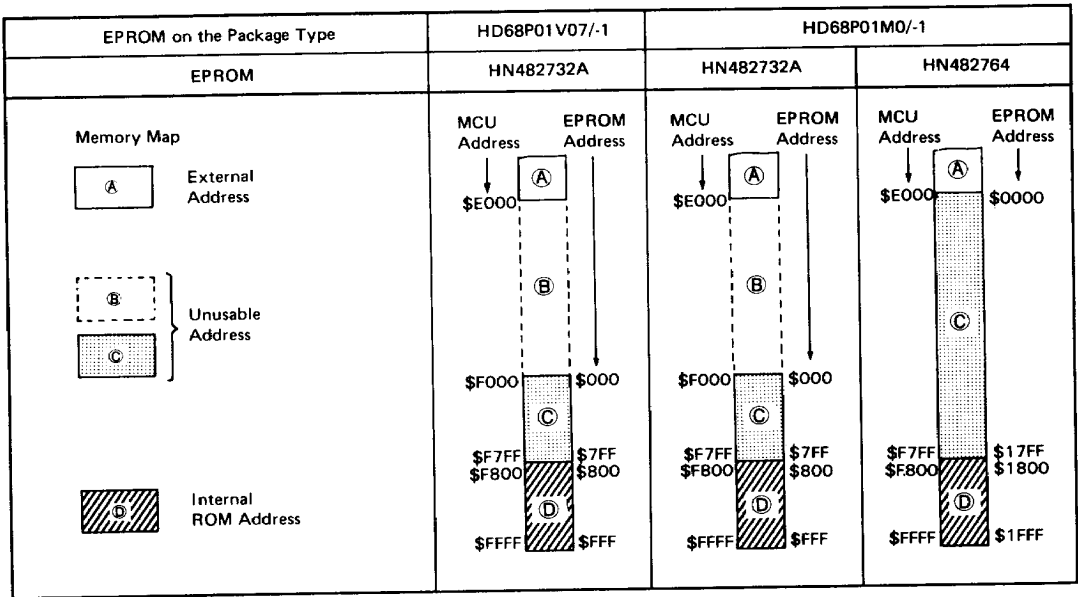

Figure 27 Memory Map When Emulating the HD6801S0

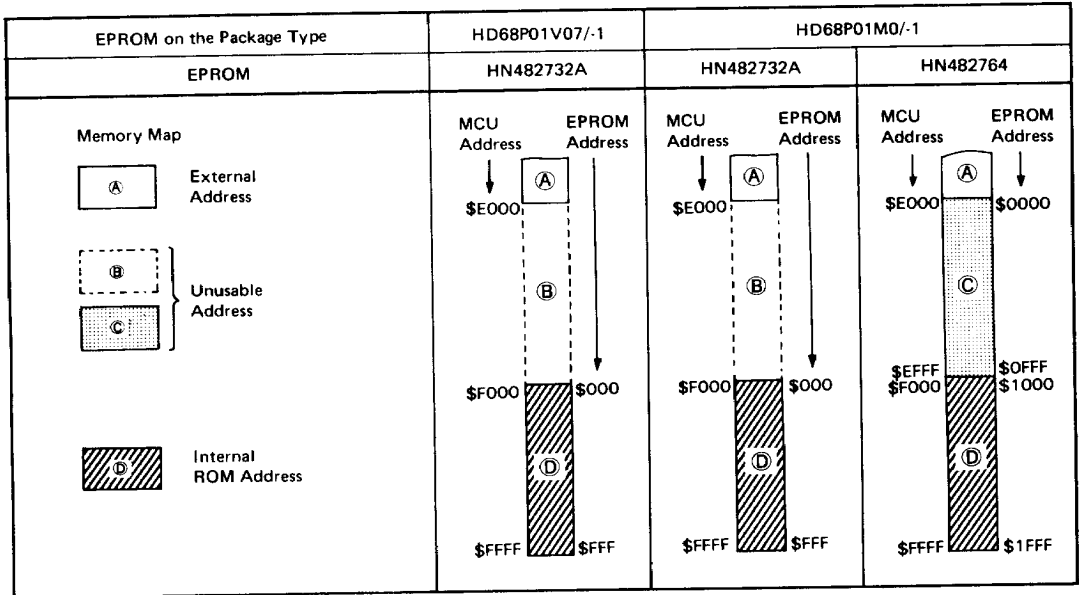

Figure 28 Memory Map When Emulating the HD6801V0



■ **PRECAUTION TO USE EPROM ON THE PACKAGE 8-BIT SINGLE-CHIP MICROCOMPUTER**

As this microcomputer takes a special packaging type with pin sockets on its surface, pay attention to the followings;

- (1) Do not apply higher electro-static voltage or serge voltage etc. than maximum rating, or it may cause permanent damage to the device.
- (2) There are 28 pin sockets on its surface. When using 32k

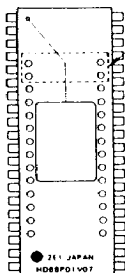

Let the index-side four pins open. When using 24 pin EPROM, match its index and insert it into lower 24 pin sockets.

- (3) When assembling this LSI into user's system products as well as the mask ROM type 8-bit single-chip microcomputer, pay attention to the followings to keep the good ohmic contact between EPROM pins and pin sockets.
 - (a) When soldering on a printed circuit board, etc., keep its condition under 250°C within 10 seconds. Over-time/temperature may cause the bonding solder of socket pins to meet and the sockets may drop.
 - (b) Keep out detergent or coater from the pin sockets at aft-solder flux removal or board coating. The flux or coater may make pin socket contactivity worse.
 - (c) Avoid the permanent use of this LSI under the ever-vibratory place and system.
 - (d) Repeating insertion/removal of EPROMs may damage the contactivity of the pin sockets, so it is recommended to assemble new ones to your system products.
- (4) In order to perform the normal operation at 1.25 MHz, it is recommended to use the EPROM whose access time is less than 300 ns.

Ask our sales agent about anything unclear.

■ **PRECAUTIONS**

• **PRECAUTION CONCERNING COUNTER TIMER**

- (1) **Timer Output (P₂₁)**
After CPU reset, P₂₁ is uncertain until the value of the free running counter equals the value of the output compare register or until the free running counter completes a software time-out cycle.
- (2) **Initialization of ICF**
ICF should be cleared by software after initiating a reset, otherwise ICF may be set if P₂₁ is "low" after initiating a reset.

• **PRECAUTION CONCERNING WRITE-ONLY REGISTER**
The write-only register cannot be changed like DDR for I/O ports using Read/Modify/Write instructions.

- (1) The CPU cannot read the write-only register. Proceede with Read/Modify/Write instructions as follows:
 - (i) read the data of specified address;
 - (ii) modify the data; and
 - (iii) write the modified data to original address.

The Read/Modify/Write instructions cannot be used with the write-only register like DDR.

- (2) Store instructions can be used for writing to the write-only register.

*Read/Modify/Write instructions—NEG, COM, LSR, ROR, ASR, ASL, ROL, DEC, INC, TST, CLR



■ PRECAUTION CONCERNING HD6801 SERIES SCI, TIMER STATUS FLAG

● Caution for the HD6801 Family SCI, TIMER Status Flag

The flags shown in Table 19 are cleared by reading/writing (flag reset condition) the data register corresponding to each flag after reading the status register (flag reset condition 1).

To clear the flag correctly, use the following procedure:

1. Read the status register
2. Test the flag
3. Read the data register

The SCI, Timer status flag is cleared by reading a "1" for each status flag and then reading the data register. SCI software routines should read the received data after confirming a "1" as the received status flag. Avoid reading dummy data after a "0" for the received status flag.

Table 19 Status Flag Reset Conditions

	Status Flag	Flag Reset Condition 1 (Status Register)	Flag Reset Condition 2 (Data Register)
TIMER	ICF	When each flag is "1", TRCSR/Read	ICR/Read
	OCF		OCR/Read
	TOF		TC/Read
SCI	RDRF	When Each flag is "1", TRCSR/Read	RDR/Read
	ORFE		
	TDRE		TDR/Write

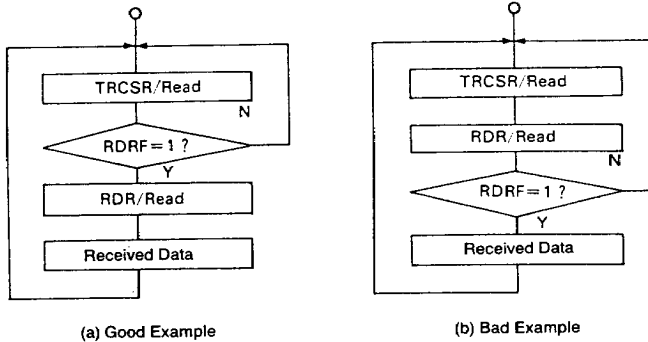

Figure 29 Software polling of SCI-RDRF

● TERMINAL CONDITION DURING RESET, AFTER RESET

Table 20 Terminal Condition During Reset, After Reset

CPU Mode	0	1	2	3	4	5	6	7
During Reset	Port 1	I Z	←	←	←	←	←	←
	Port 2	I Z	←	←	←	←	←	←
	Port 3	I Z	←	←	←	←	←	←
	Port 4	I H	←	←	←	←	←	←
	SC ₁	I/O H	←	←	←	I H	O H	I/O H
	SC ₂	O H	←	←	←	←	←	←
After Reset	Port 1	I Z	←	←	←	←	←	←
	Port 2	I Z	←	←	←	←	←	←
	Port 3	I/O ABL/DB	←	←	←	I Z	I DB	I/O ABL/DB
	Port 4	O ABH	←	←	←	I H	←	←
	SC ₁	O AS	←	←	←	I H	O IOS	O AS
	SC ₂	O R/W	←	←	←	O OS3	O R/W	←

I : Input
O : Output
I/O : Input/Output
Upper : Input Condition
Lower : Level, Terminal Function

H : High Level
L : Low Level
Z : High Impedance

DB : Data Bus
ABL : Address Bus Low
ABH : Address Bus High

AS : Address Strobe
R/W : Read/Write
IOS : IOS Signal
OS3 : OS3 Signal

