

SOT-23 Plastic-Encapsulate Transistors

SS8050 TRANSISTOR (NPN)

FEATURES

Complimentary to SS8550

MARKING: Y1

MAXIMUM RATINGS (TA=25°C unless otherwise noted)

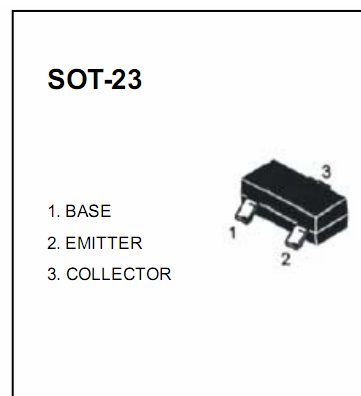

Symbol (符号)	Parameter (参数名称)	Value (额定值)	Units (单位)
VCBO	Collector-Base Voltage (集电极-基极电压)	40	V
VCEO	Collector-Emitter Voltage (集电极-发射极电压)	25	V
VEBO	Emitter-Base Voltage (发射极-基极电压)	5	V
IC	Collector Current -Continuous (集电极电流)	1.5	A
PC	Collector Power Dissipation (耗散功率)	0.625	W
Tj	Junction Temperature (结温)	150	°C
Tstg	Storage Temperature (储存温度)	-55-150	°C

ELECTRICAL CHARACTERISTICS (Tamb=25°C unless otherwise specified)

Parameter (参数名称)	Symbol (符号)	Test conditions (测试条件)	MIN (最小值)	TYP (典型值)	MAX (最大值)	UNIT (单位)
Collector-base breakdown voltage 集电极-基极击穿电压	V(BR)CBO	IC= 100μA, IE=0	40			V
Collector-emitter breakdown voltage 集电极-发射极击穿电压	V(BR)CEO	IC= 1mA, IB=0	25			V
Emitter-base breakdown voltage 发射极-基极击穿电压	V(BR)EBO	IE=100μA, IC=0	5			V
Collector cut-off current 集电极-基极截止电流	ICBO	VCB=20 V, IE=0			1	μ A
Collector cut-off current 集电极-发射极截止电流	ICEO	VCE=15V, IB=0			10	μ A
Emitter cut-off current 发射极-基极截止电流	IEBO	VEB=5V, IC=0			1	μ A
DC current gain 直流电流增益	hFE	VCE=1V, IC= 100mA	80		400	
Collector-emitter saturation voltage 集电极-发射极饱和压降	VCE(sat)	IC=800mA, IB= 80mA			0.5	V
Base-emitter saturation voltage 发射极-基极饱和压降	VBE(sat)	IC=800mA, IB= 80mA			1.2	V

CLASSIFICATION OF hFE

Range	80-100	100-200	200-400	400-600