

swissbit®

Product Data Sheet

Industrial
MICRO SD Memory Card

S-300u Series
SPI, SD and SDHC compliant

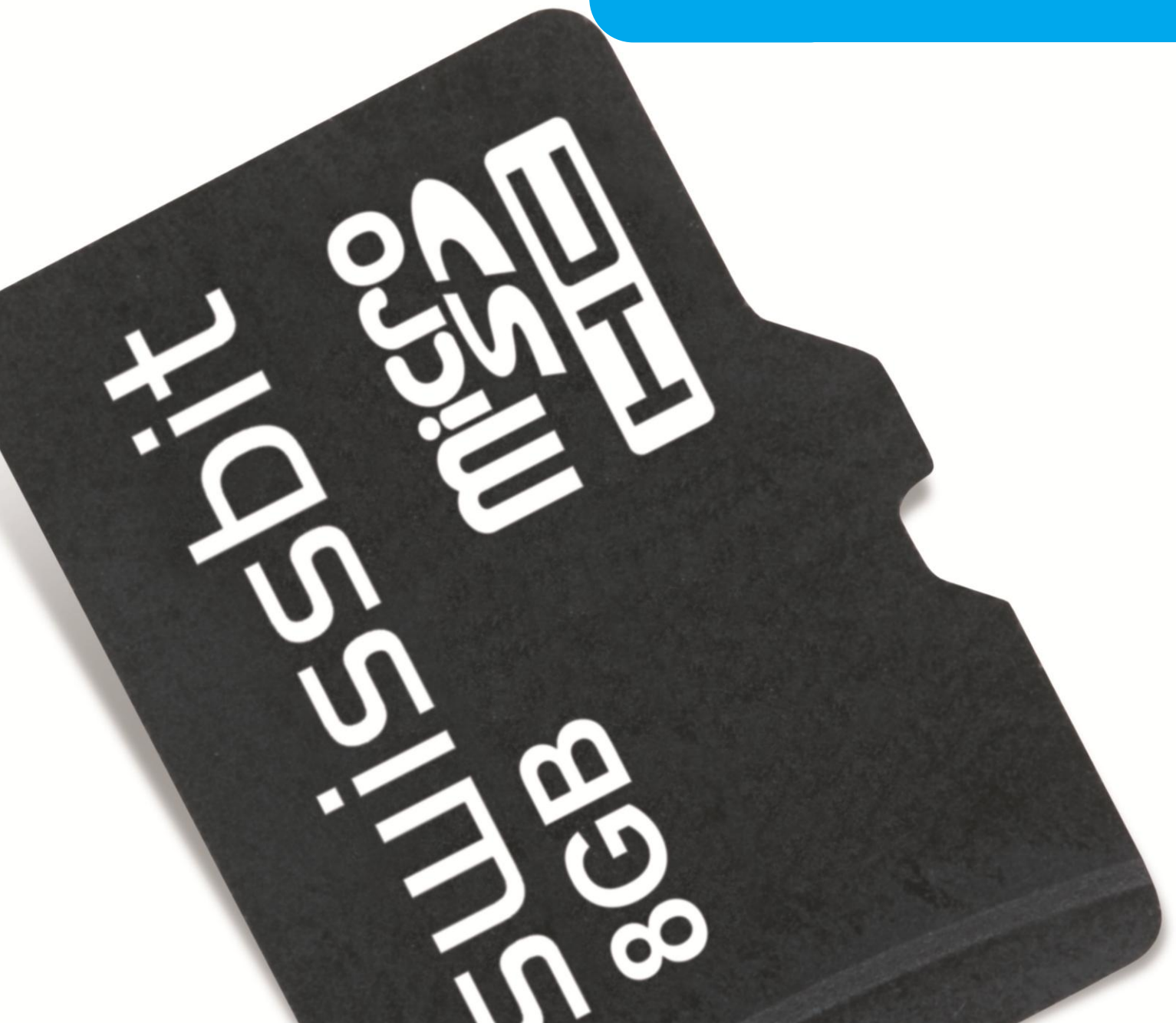

S-300U SERIES

MICRO SD Memory Card

1 Feature summary

- Highly-integrated memory controller
 - Fully compliant with SD Memory Card specification SD1.01, SD1.1, SD2.0 and SD3.01 and MICRO SD Memory Card Addendum 4.00
- Standard MICRO SD Memory Card form factor
 - 15.0mm x 11.0mm x 0.7mm
- Operating voltage 2.7...3.6V
- Low-power CMOS technology
- High reliability
 - MTBF: > 3,000,000 hours
 - Number of insertions: > 10,000
 - Extended Temperature range -25° up to 85°C
 - Industrial Temperature range -40° up to 85°C
- Hot swappable
- High performance
 - Speed class
 - 2GB Card speed class 6
 - 1,GB, 4GB, 8GB speed class 10
 - SD burst up to 25MB/s
 - SD Low/High speed 0...25/50MHz clock rate
 - Flash burst up to 40MB/s
 - Flash Bus interleave
- Operating bus modes: SD 1 & 4bit and SPI
- Error Correction up to 24bit/1KB BCH ECC
- Wear Leveling: equal wear leveling of static and dynamic data
The wear leveling assures that dynamic data as well as static data is balanced evenly across the memory. With that the maximum write endurance of the device is guaranteed.
- Write Endurance: Due to advanced wear leveling an even use of the entire flash is guaranteed, regardless how much "static" (0s) data is stored. Example: If the average file size is 10MByte and the total capacity is 8GByte, 48Mio write cycles can be performed.
- Available densities
 - 1, 2, 4, and 8GBytes (SLC NAND Flash)
- Controlled BOM
- Life Cycle Management



2 Order Information

2.1 Standard product list

Table 1: Standard Product List

Density	Part Number
1GB	SFSD1024NgBW1MT-t-ME-1x1-STD
2GB	SFSD2048NgBW1MT-t-ME-1x1-STD
4GB	SFSD4096NgBW1MT-t-DF-1x1-STD
8GB	SFSD8192NgBW1MT-t-QG-1x1-STD

g defines the product generation

x defines the FW

t defines the temperature range (E=-25°C to +85°C, I=-40°C to +85°C)

2.2 Current product generation

Table 2: Standard Product List

Density	Part Number
	Extended Temperature grade
1GB	SFSD1024N1BW1MT-E-ME-111-STD
2GB	SFSD2048N1BW1MT-E-ME-111-STD
4GB	SFSD4096N1BW1MT-E-DF-111-STD
8GB	SFSD8192N1BW1MT-E-QG-111-STD
	Industrial Temperature grade
1GB	SFSD1024N1BW1MT-I-ME-111-STD
2GB	SFSD2048N1BW1MT-I-ME-111-STD
4GB	SFSD4096N1BW1MT-I-DF-111-STD
8GB	SFSD8192N1BW1MT-I-QG-111-STD

3 Contents

1 FEATURE SUMMARY	2
2 ORDER INFORMATION.....	3
2.1 STANDARD PRODUCT LIST	3
2.2 CURRENT PRODUCT GENERATION	3
3 CONTENTS	4
4 PRODUCT SPECIFICATION.....	5
4.1 SYSTEM PERFORMANCE.....	5
4.2 ENVIRONMENTAL SPECIFICATIONS	6
4.2.1 Recommended Operating Conditions	6
4.2.2 Recommended Storage Conditions	6
4.2.3 Humidity & ESD	6
4.2.4 Environmental Conditions	6
4.3 PHYSICAL DIMENSIONS.....	6
4.4 RELIABILITY.....	6
5 CAPACITY SPECIFICATION	6
6 CARD PHYSICAL	7
6.1 PHYSICAL DESCRIPTION	7
7 ELECTRICAL INTERFACE	8
7.1 ELECTRICAL DESCRIPTION.....	8
7.2 DC CHARACTERISTICS	9
7.3 SIGNAL LOADING.....	9
7.4 AC CHARACTERISTICS	10
8 HOST ACCESS SPECIFICATION	12
8.1 SD AND SPI BUS MODES	12
8.1.1 SD Bus Mode Protocol	12
8.1.2 SPI Bus Mode Protocol.....	13
8.1.3 Mode Selection.....	13
8.2 CARD REGISTERS.....	14
9 DECLARATION OF CONFORMITY	17
10 ROHS AND WEEE UPDATE FROM SWISSBIT.....	18
11 PART NUMBER DECODER.....	20
11.1 MANUFACTURER	20
11.2 MEMORY TYPE.....	20
11.3 PRODUCT TYPE.....	20
11.4 CAPACITY	20
11.5 PLATFORM	20
11.6 GENERATION	20
11.7 MEMORY ORGANIZATION.....	20
11.8 TECHNOLOGY.....	20
11.9 CHANNELS	20
11.10 FLASH CODE	20
11.11 TEMP. OPTION	21
11.12 DIE CLASSIFICATION	21
11.13 PIN MODE.....	21
11.14 CONFIGURATION XYZ.....	21
11.15 OPTION.....	21

12 SWISSBIT LABEL SPECIFICATION	22
12.1 FRONT SIDE MARKING.....	22
12.2 BACK SIDE MARKING.....	22
13 REVISION HISTORY.....	23

4 Product Specification

The MICRO SD Memory Card is a small form factor non-volatile memory card which provides high capacity data storage. Its aim is to capture, retain and transport data, audio and images, facilitating the transfer of all types of digital information between a large variety of digital systems.

The card operates in two basic modes:

- **SD/SDHC card mode**
- **SPI mode**

The MICRO SD Memory Card also supports SD **High Speed mode** with up to 50MHz clock frequency.

The cards are compliant with

- SD Memory card Specification Part 1, Physical layer Specification V3.01
- SD Memory card Specification Part 2, File System Specification V3.00
- SD Memory card Specification Part 3, Security Specification V3.00
- MICRO SD Memory Card Addendum V4.00

Simplified specifications are available at https://www.sdcard.org/downloads/pls/simplified_specs/

The Card has an internal **intelligent controller** which manages interface protocols, data storage and retrieval as well as hardware **BCH Error Correction Code (ECC), defect handling, diagnostics and clock control.**

The **advanced wear leveling** mechanism assures an equal usage of the Flash memory cells to extend the life time.

The hardware BCH-code ECC allows to **detect and correct up to 24 defect bits per 1kByte.**

The card has a **power-loss management feature** to prevent data corruption after power-down. The power consumption is very low.

The cards are RoHS compliant and lead-free.

4.1 System Performance

Table 3: Performance

System Performance		typ	max	Unit
Burst Data transfer Rate (max SD clock 50MHz)			25	MB/s
Sustained Sequential Read	1GB	21 ⁽¹⁾⁽²⁾	24 ⁽¹⁾⁽³⁾	
	2GB	20 ⁽¹⁾⁽²⁾	24 ⁽¹⁾⁽³⁾	
	4...8GB	20 ⁽¹⁾⁽²⁾	24 ⁽¹⁾⁽³⁾	
Sustained Sequential Write	1GB	18 ⁽¹⁾⁽²⁾	22 ⁽¹⁾⁽³⁾	
	2GB	11 ⁽¹⁾⁽²⁾	12 ⁽¹⁾⁽³⁾	
	4...8GB	17 ⁽¹⁾⁽²⁾	22 ⁽¹⁾⁽³⁾	

1. All values refer to Micron Flash 8/16Gb MICRO SD Memory Card in SD mode 50MHz, cycle time 20ns,
2. Sustained Speed measured with USB-SD Memory Card reader. It depends on burst speed, flash number, and file size.
3. Maximum values were measured with Testmetrix tester.

4.2 Environmental Specifications

4.2.1 Recommended Operating Conditions

Table 4: MICRO SD Memory Card Recommended Operating Conditions

Parameter	min	typ	max	unit
Extended Operating Temperature	-25	25	85	°C
Industrial Operating Temperature	-40	25	85	°C

4.2.2 Recommended Storage Conditions

Table 5: MICRO SD Memory Card Recommended Storage Conditions

Parameter	min	typ	max	unit
Extended Storage Temperature	-25	25	85	°C
Industrial Operating Temperature	-40	25	100	°C

4.2.3 Humidity & ESD

Table 6: Humidity & ESD

Parameter	Operating	Non Operating
Humidity (non-condensing)	operation: 95% RH @25°C storage: 93% RH @40°C, 500h	
EMC / EMI	Non Contact Pads area: ±8 kV (air discharge) Human body model according to IEC61000-4-2	Contact Pads: ±4 kV, Human body model according to IEC61000-4-2

4.2.4 Environmental Conditions

Table 7: Environmental Conditions

Parameter	Operating	Non Operating
UV light exposure	UV: 254nm, 15Ws/cm ² according to ISO7816-1	
Durability	10,000 mating cycles	
Drop test	1.5m free fall	
Bending / Torque	10N / 0.10Nm ±2.5° max	
Mechanical Shock	1500G, 0,5ms, half sine wave ±xyz-axis, five pulses each Non operating, JESD22B110 Condition B	
Vibration	50G, 1.5mm p-p, 20..2000Hz, sweep xyz-axis, five pulses each, Non operating MIL-STD-883 M2007.3 Condition B	

4.3 Physical Dimensions

Table 8: Physical Dimensions

Outer Physical Dimensions	Value	Unit
Length	15.0±0.1	mm
Width	11.0±0.1	
Thickness	0.7 (1.0)±0.1	
Weight (typ.)	0.4	g

4.4 Reliability

Table 9: Reliability

Parameter	Value
Data Retention @ 25°C	10 years (JEDEC47G)

5 Capacity specification

Table 10: MICRO SD Memory Card capacity specification

Capacity	Sectors	Total addressable capacity (Byte)
1GB	2'001'920	1'024'983'040
2GB	4'016'128	2'056'257'536
4GB	8'042'496	4'117'757'952
8GB	16'136'192	8'261'730'304

6 Card physical

6.1 Physical description

The MICRO SD Memory Card contains a single chip controller and Flash memory module(s). The controller interfaces with a host system allowing data to be written to and read from the Flash memory module(s).

Figure 1 and Figure 2 show card dimensions.

Figure 1: Mechanical Dimensions MICRO SD Memory Card (side and top, simplified)

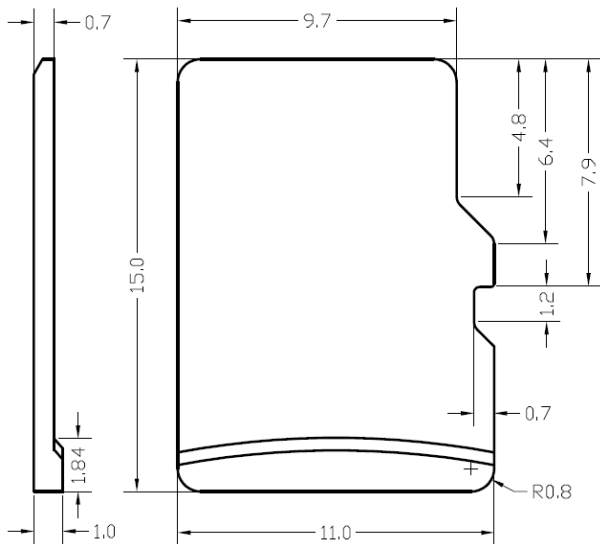
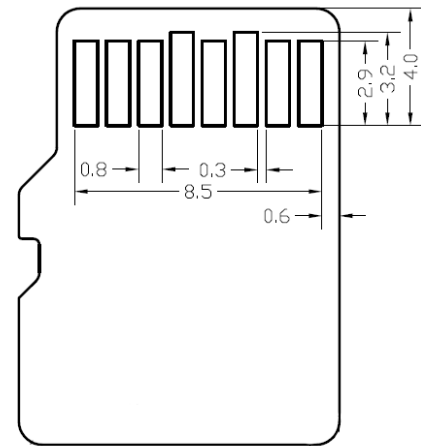

Figure 2: Mechanical Dimensions MICRO SD Memory Card (bottom side with connector)



Gold pads thickness: 0.8µm / 30µinch

7 Electrical interface

7.1 Electrical description

Figure 3: MICRO SD Memory Card Block Diagram

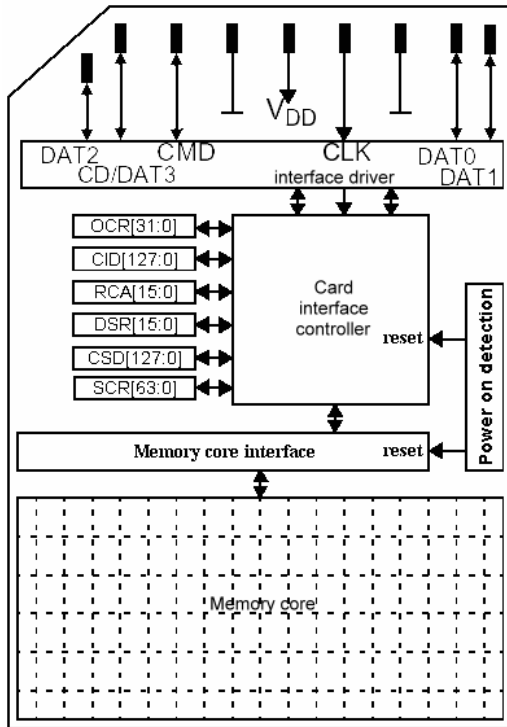

Figure 4: MICRO SD Memory Card Shape and Interface (Bottom View)

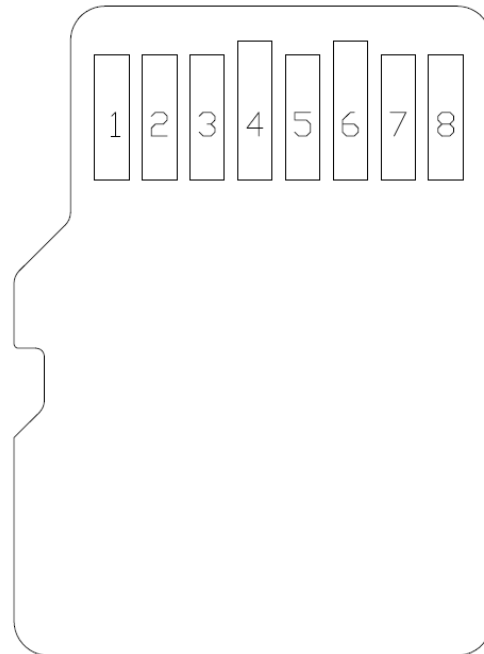

Table 11: MICRO SD Memory Card Pad Assignment

Pin #	SD Mode			SPI Mode		
	Name	Type ¹	Description	Name	Type ¹	Description
1	DAT2 ⁵	I/O/PP	Data Line [Bit 2]	RSV		
2	CD/DAT3 ²	I/O/PP ³	Card Detect/ Data Line [Bit 3]	CS	I ³	Chip Select (negative true)
3	CMD	PP	Command/Response	DI	I	Data In
4	VDD	S	Supply voltage	VDD	S	Supply voltage
5	CLK	I	Clock	SCLK	I	Clock
6	VSS	S	Supply voltage ground	VSS	S	Supply voltage ground
7	DAT0	I/O/PP	Data Line [Bit 0]	DO	O/PP	Data Out
8	DAT1 ⁴	I/O/PP	Data Line [Bit 1]	RSV		

Notes:

- 1) S: power supply; I: input; O: output using push-pull drivers; PP: I/O using push-pull drivers;
- 2) The extended DAT lines (DAT1-DAT3) are input on power up. They start to operate as DAT lines after SET_BUS_WIDTH command. The Host shall keep its own DAT1-DAT3 lines in input mode, as well, while they are not used.
- 3) At power up this line has a 50kOhm pull up enabled in the card. This resistor serves two functions Card detection and Mode Selection. For Mode Selection, the host can drive the line high or let it be pulled high to select SD mode. If the host wants to select SPI mode it should drive the line low. For Card detection, the host detects that the line is pulled high. This pull-up should be disconnected by the user, during regular data transfer, with SET_CLR_CARD_DETECT (ACMD42) command
- 4) DAT1 line may be used as Interrupt Output (from the Card) in SDIO mode during all the times that it is not in use for data transfer operations (refer to "SDIO Card Specification" for further details).
- 5) DAT2 line may be used as Read Wait signal in SDIO mode (refer to "SDIO Card Specification" for further details).

7.2 DC characteristics

Measurements are at Recommended Operating Conditions unless otherwise specified.

Table 12: DC Characteristics

Symbol	Parameter	min	typ	max	unit	notes
	Peak Voltage on all Lines	-0.3		VDD+0.3	V	
VIL	Input LOW Voltage	-0.3		0.25*VDD	V	
VIH	Input HIGH Voltage	0.625*VDD		VDD+0.3	V	
VOL	Output LOW Voltage			0.125*VDD	V	@ 100µA
VOH	Output HIGH Voltage	0.75*VDD			V	@ 100µA
IDD	Operating Current Read		50	60	mA	@ 25°C
	Operating Current Write		60	70	mA	@ 25°C
	Pre-initialization Standby Current		150	200	µA	@ 25°C
	Post-initialization Standby Current			130	150	µA
			400	600	µA	@ 85°C
ILI	Input Leakage Current	-10		10	µA	without pull up R
ILO	Output Leakage Current	-10		10	µA	

Table 13: MICRO SD Memory Card Recommended Operating Conditions

Symbol	Parameter	min	typ	max	unit	
VDD	Supply Voltage	Normal Operating Status	2.7		3.6	V
		Basic Communication (CMD0, CMD15, CMD55, ACMD41)	2.0	3.3	3.6	V
-	Power Up Time (from 0V to VDD min)			250	ms	

7.3 Signal Loading

The total capacitance C_L is the sum of the bus master capacitance C_{HOST} , the bus capacitance C_{BUS} , and the capacitance C_{CARD} of the card connected to the line:

$$C_L = C_{HOST} + C_{BUS} + C_{CARD}$$

To allow the sum of the host and bus capacitances to be up to 20pF for the card, the following conditions in the table below are met by the card.

Table 14: Signal loading

Parameter	Symbol	Min	Max	Unit	Notes
Pull up resistance	R_{CMD}	10	100	kOhm	To prevent bus floating
Pull up resistance	R_{DAT}	10	100	kOhm	To prevent bus floating
Bus signal line capacitance	C_L		40	pF	Single card
Signal card capacitance	C_{card}		10	pF	Single card
Signal line inductance			16	nH	$f \leq 20\text{MHz}$

Figure 5: Signal Loading (MICRO SD Memory Card has no WP slider)

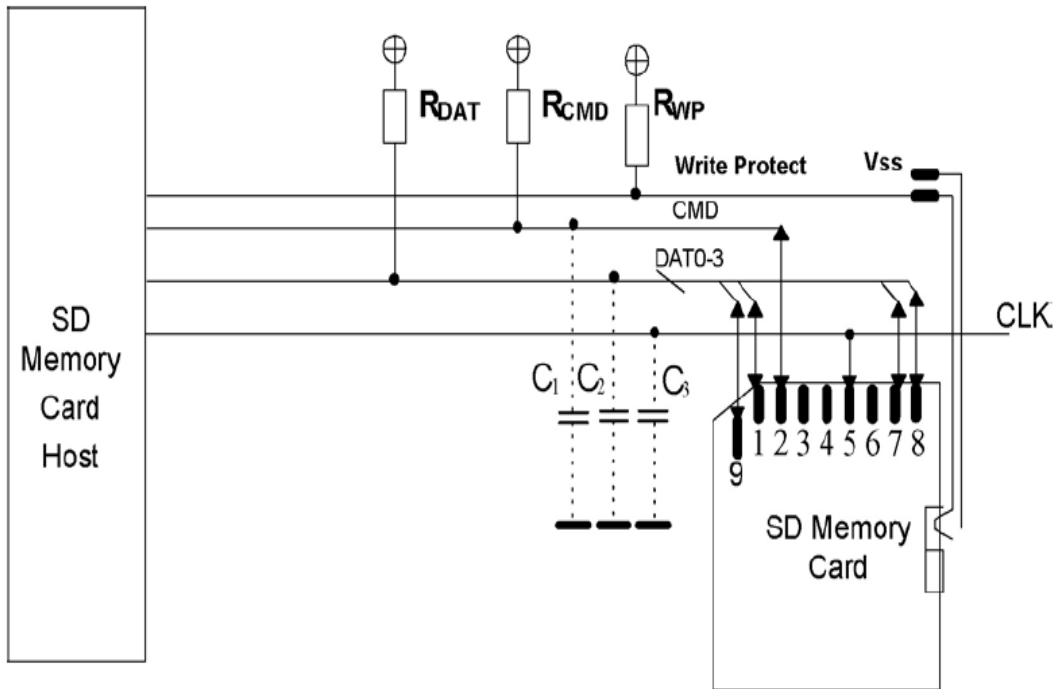

7.4 AC characteristics

Table 15: AC Characteristics Low Speed Mode

Parameter	Symbol	Min	Max	Unit	Notes
Clock frequency in data transfer mode	f _{PP}	0	25	MHz	CL ≤ 100pF
Clock frequency in card id mode	f _{OD}	0	400	KHz	CL ≤ 250pF
Clock low time	t _{WL}	10/50		ns	CL ≤ 100/250pF
Clock high time	t _{WH}	10/50		ns	
Clock rise time	t _{TLH}		10/50	ns	
Clock fall time	t _{THL}		10/50	ns	
CMD, DAT input setup time	t _{ISU}	5		ns	CL ≤ 25pF
CMD, DAT input hold time	t _{IH}	5		ns	
CMD, DAT output delay time	t _{ODLY}	0	14	ns	CL ≤ 25pF, data transfer
CMD, DAT output delay time	t _{ODLY}	0	50	ns	CL ≤ 25pF, identification

Notes

1. Rise and fall times are measured from 10% to 90% of voltage level.
2. CLK referenced to VIH min and VIL max.
3. CMD and DAT inputs and outputs referenced to CLK.
4. 0Hz means to stop the clock. The given minimum frequency range is for cases where a continuous clock is required
5. Specified for one card

Figure 6: AC Characteristics Low Speed Mode

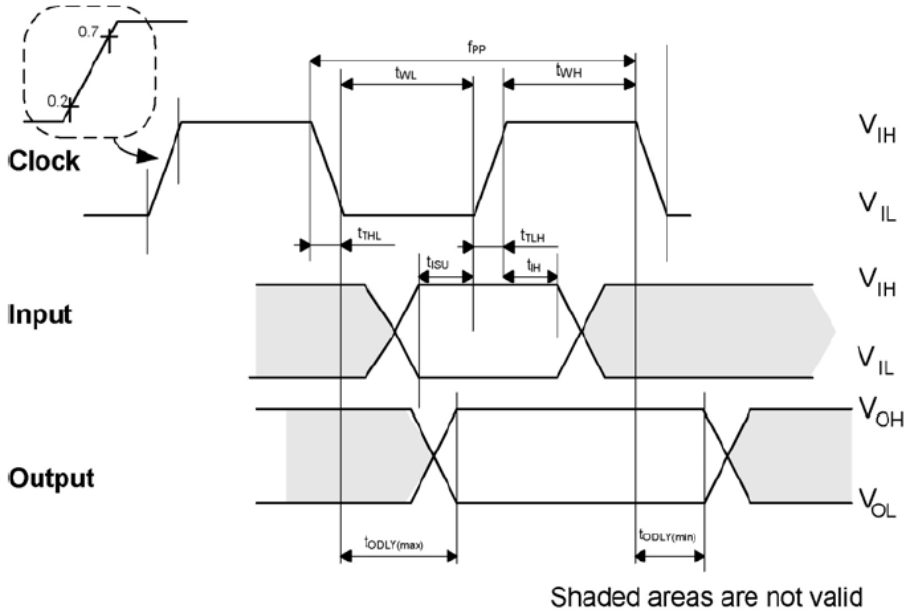

Table 16: AC Characteristics High Speed Mode

Parameter	Symbol	Min	Max	Unit	Notes
Clock frequency in data transfer mode	fPP	0	50	MHz	CL≤10pF
Clock low time	tWL	7.0		ns	
Clock high time	tWH	7.0		ns	
Clock rise time	tTLH		3	ns	
Clock fall time	tTHL		3	ns	
CMD, DAT input setup time	tISU	6		ns	
CMD, DAT input hold time	tIH	2		ns	
CMD, DAT output delay time during data transfer mode	tODLY		14	ns	
CMD, DAT output hold time	tOH	2.5		ns	

Notes

1. Rise and fall times are measured from 10% to 90% of voltage level.
2. CLK referenced to V_{IH} min and V_{IL} max.
3. CMD and DAT inputs and outputs referenced to CLK.
4. In order to satisfy severe timing, the host shall drive only one card with max 40pF total at each line.

Figure 7: AC Characteristics High Speed Mode

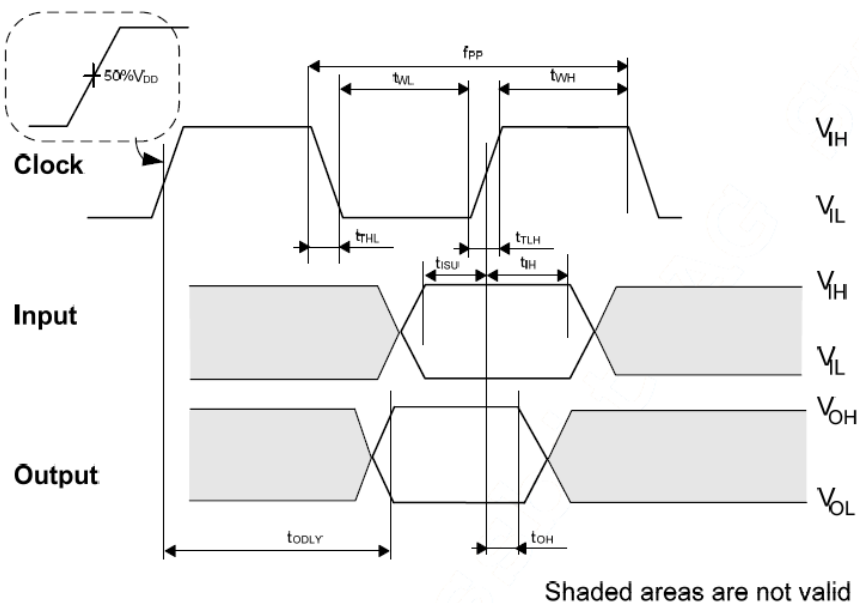

8 Host access Specification

The following chapters summarize how the host accesses the card:

- Chapter 8.1 summarizes the SD and SPI buses.
- Chapter 8.2 summarizes the registers.

8.1 SD and SPI Bus Modes

The card supports SD and the SPI Bus modes. Application can chose either one of the modes. Mode selection is transparent to the host. The card automatically detects the mode of the reset command and will expect all further communication to be in the same communication mode. The SD mode uses a 4-bit high performance data transfer, and the SPI mode provides compatible interface to MMC host systems with little redesign, but with a lower performance.

8.1.1 SD Bus Mode Protocol

The SD Bus mode has a single master (host) and multiple slaves (cards) synchronous topology. Clock, power, and ground signals are common to all cards. After power up, the SD Bus mode uses DAT0 only; after initialization, the host can change the cards' bus width from 1 bit (DAT0) to 4 bits (DAT0-DAT3). In high speed mode, only one card can be connected to the bus.

Communication over the SD bus is based on command and data bit streams which are initiated by a start bit and terminated by a stop bit.

- **Command:** a command is a token which starts an operation. A command is sent from the host either to a single card (addressed command) or to all connected cards (broadcast command). A command is transferred serially on the CMD line.
- **Response:** a response is a token which is sent from an addressed card, or (synchronously) from all connected cards, to the host as an answer to a previously received command. A response is transferred serially on the CMD line.
- **Data:** data can be transferred from the card to the host or vice versa. Data is transferred via the data lines.

The SD bus signals are listed in Table 17, and the SD bus topology is illustrated in Figure 8: SD Bus Topology.

Table 17: SD Bus Signals

Signal	Description
CLK	Host to card clock signal
CMD	Bidirectional Command/Response signal
DAT0-DAT3	4 Bidirectional data signals
Vdd, Vss	Power and Ground

Figure 8: SD Bus Topology

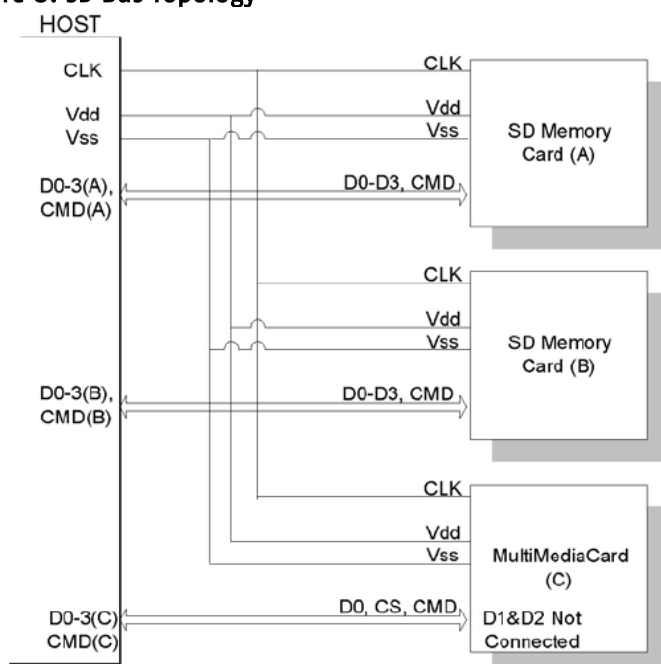

8.1.2 SPI Bus Mode Protocol

The Serial Parallel Interface (SPI) Bus is a general purpose synchronous serial interface. The SPI mode consists of a secondary communication protocol. The interface is selected during the first reset command after power up (CMD0) and it cannot be changed once the card is powered on.

While the SD channel is based on command and data bit streams which are initiated by a start bit and terminated by a stop bit, the SPI channel is byte oriented. Every command or data block is built of 8-bit bytes and is byte aligned to the CS signal.

The card identification and addressing methods are replaced by a hardware Chip Select (CS) signal. There are no broadcast commands. For every command, a card (slave) is selected by asserting (active low) the CS signal. The CS signal must be continuously active for the duration of the SPI transaction (command, response and data). The only exception occurs during card programming, when the host can de-assert the CS signal without affecting the programming process.

The bidirectional CMD and DAT lines are replaced by unidirectional *dataIn* and *dataOut* signals.

The SPI bus signals are listed Table 18 and the SPI bus topology is illustrated in Figure 9.

Table 18: SPI Bus Signals

Signal	Description
/CS	Host to card chip select
CLK	Host to card clock signal
Data In	Host to card data signal
Data Out	Card to host data signal
Vdd, Vss	Power and ground

Figure 9: SPI bus topology

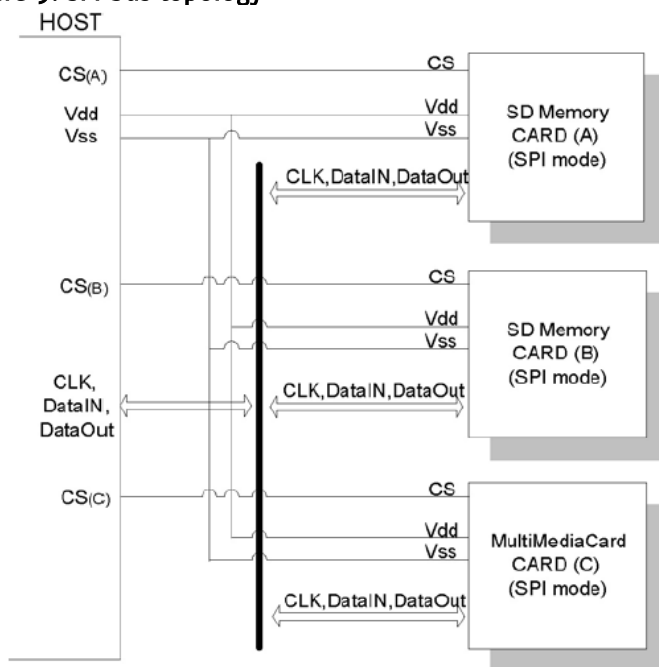

8.1.3 Mode Selection

The SD Memory Card wakes up in the SD mode. It will enter SPI mode if the CS signal is asserted (negative) during the reception of the reset command (CMD0) and the card is in *idle_state*. If the card recognizes that the SD mode is required it will not respond to the command and remain in the SD mode.

If SPI mode is required the card will switch to SPI and respond with the SPI mode R1 response.

The only way to return to the SD mode is by entering the power cycle. In SPI mode the SD Memory Card protocol state machine is not observed. All the SD Memory Card commands supported in SPI mode are always available. During the initialization sequence, if the host gets Illegal Command indication for ACMD41 sent to the card, it may assume that the card is Multimedia Card. In that case it should re-start the card as Multimedia Card using CMD0 and CMD1.

8.2 Card Registers

The MICRO SD Memory Card has five registers. Refer to Table 19 to Table 24 for detail.

Table 19: MICRO SD Memory Card registers

Register Name	Bit Width	Description	Function
CID	128	Card Identification information	This register contains the card identification information used during the Card Identification phase.
OCR	32	Operation Conditions Registers	This register describes the operating voltage range and contains the status bit in the power supply.
CSD	128	Card specific information	This register provides information on how to access the card content. Some fields of this register are writeable by PROGRAM_CSD (CMD27).
SCR	64	SD Memory Card's Special features	This register provides information on special features.
RCA	16	Relative Card Address	This register carries the card address is SD Card mode.

Table 20: CID register

Register Name	Bit Width	Description	typ. value
MID	8	Manufacture ID	TBD (0x5d)
OID	16	OEM/Application ID	TBD (0x5342)
PNM	40	Product Name	TBD ("NgBWc") g=generation c=number of channels
PRV	8	Product Revision	0xgg
PSN	32	Product Serial Number	xxxxxxxx
—	4	Reserved	0x0
MDT	12	Manufacture Date	oxyym
CRC	7	Check sum of CID contents	chksum
—	1	Not used; always=1	1

Table 21: OCR register

OCR bit position	VDD voltage window	typ. value	OCR bit position	VDD voltage window	typ. value
0-3	Reserved	0	15	2.7-2.8	1
4	1.6-1.7	0	16	2.8-2.9	1
5	1.7-1.8	0	17	2.9-3.0	1
6	1.8-1.9	0	18	3.0-3.1	1
7	1.9-2.0	0	19	3.1-3.2	1
8	2.0-2.1	0	20	3.2-3.3	1
9	2.1-2.2	0	21	3.3-3.4	1
10	2.2-2.3	0	22	3.4-3.5	1
11	2.3-2.4	0	23	3.5-3.6	1
12	2.4-2.5	0	24-30	Reserved	
13	2.5-2.6	0	30	Card Capacity Status (CCS)	*1)
14	2.6-2.7	0	31	0=busy; 1=ready	*2)

Notes

1. This bit is valid only when the card power up status bit is set.
2. This bit is set to LOW if the card has not finished the power up routine.

Table 22: CSD register

Register Name	Bits	Bit Width	Description	typ. Value 1GB, 2GB	typ. Value 4GB, 8GB
CSD_STRUCTURE	127:126	2	CSD structure	00	01
–	125:120	6	Reserved	000000	000000
TAAC	119:112	8	Data read access time 1	01011110	00001110
NSAC	111:104	8	Data read access time 2 (CLK cycle)	00000000	00000000
TRAN_SPEED	103:96	8	Data transfer rate	00110010	00110010
CCC	95:84	12	Card command classes	010110110101	010110110101
READ_BLK_LEN	83:80	4	Read data block length	1010	1001
READ_BLK_PARTIAL	79	1	Partial blocks for read allowed	1	0
WRITE_BLK_MISALIGN	78	1	Write block misalignment	0	0
READ_BLK_MISALIGN	77	1	Read block misalignment	0	0
DSR_IMP	76	1	DSR implemented	0	0
–	75:74	2	Reserved	00	–
C_SIZE	73:62	12	Device size	xxx*)	–
VDD_R_CURR_MIN	61:59	3	VDD min read current	101	–
VDD_R_CURR_MAX	58:56	3	VDD max read current	101	–
VDD_W_CURR_MIN	55:53	3	VDD min write current	101	–
VDD_W_CURR_MAX	52:50	3	VDD max write current	101	–
C_SIZE_MULT	49:47	3	Device size multiplier	111*)	–
–	75:70	6	Reserved	–	000000
C_SIZE	69:48	22	Device size	–	xxx*)
–	47	1	Reserved	–	0
ERASE_BLK_EN	46	1	Erase single block enable	1	1
SECTOR_SIZE	45:39	7	Erase sector size	1111111	1111111
WP_GRP_SIZE	38:32	7	Write protect group size	0111111*)	0000000
WP_GRP_ENABLE	31	1	Write protect group enable	0	0
–	30:29	2	Reserved	00	00
R2W_FACTOR	28:26	3	Write speed factor	101	010
WRITE_BLK_LEN	25:22	4	Write data block length	1010*)	1001*)
WRITE_BLK_PARTIAL	21	1	Partial blocks for write allowed	0	0
–	20:16	5	Reserved	00000	00000
FILE_FORMAT_GRP	15	1	File format group	0 W(1)	0 W(1)
COPY	14	1	Copy flag	0 W(1)	0 W(1)
PERM_WRITE_PROTECT	13	1	Permanent write protection	0 W(1)	0 W(1)
TMP_WRITE_PROTECT	12	1	Temporary write protection	0 W	0 W
FILE_FORMAT	11:10	2	File format	00 W(1)	00 W(1)
–	9:8	2	Reserved	00 W	00 W
CRC	7:1	7	Checksum of CSD contents	xxxxxxx W	xxxxxxx W
–	0	1	Always=1	1	1

*) Drive Size and block sizes vary with card capacity

≤2Gb

memory capacity = BLOCKNR * BLOCK_LEN

Where

BLOCKNR = (C_SIZE+1) * MULT

MULT = $2^{C_SIZE_MULT+2}$ (C_SIZE_MULT < 8)

BLOCK_LEN = $2^{READ_BL_LEN}$, (READ_BL_LEN < 12)

>2Gb

memory capacity = (C_SIZE+1) * 512kByte

W value can be changed with CMD27 (PROGRAM_CSD)

W(1) value can be changed ONCE with CMD27 (PROGRAM_CSD)

Table 23: SCR register

Field	Bit Width	typ Value	remark
SCR_STRUCTURE	4	0000	SCR 1.01...2.00
SD_SPEC	4	0010	SD 2.0 or 3.0
DATA_STAT_AFTER_ERASE	1	0	0
SD_SECURITY	3	010 or 011	Version 1.01 (SD) or 2.00 (SDHC)
SD_BUS_WIDTHS	4	0101	1 or 4 bit
Reserved	16	0	0
Reserved	32	0	0

Table 24: RCA register

Field	Bit Width	typ Value
RCA	16	0x0000*)

*) After Initialization the card can change the RCA register.

9 CE Declaration of Conformity

We

Manufacturer: Swissbit AG
 Industriestrasse 4
 CH-9552 Bronschhofen
 Switzerland

declare under our sole responsibility that the product

Product Type: MICRO SD Memory Card
Brand Name: SWISSMEMORY™ MICRO SD Memory Card
Product Series: S-300u
Part Number: SFSDxxxxNxBWxxx-x-xx-xxx-xxx

to which this declaration relates is in conformity with the following directives:

EN55022:2006 +A1:r B
 FCC47 Part 15 Subpart B §15.111
 EN 61000-4-2:1995 +A1:1998 + A2:2001
 EN 61000-4-3:2006+A1:2008
 2012/19/EU Category 3 (WEEE)

following the provisions of Directive

Electromagnetic compatibility 2004/108/EC
Restriction of the use of certain hazardous substances 2011/65/EU

Swissbit AG, January 2014



Manuela Kögel
 Head of Quality Management

10 RoHS and WEEE update from Swissbit

Dear Valued Customer,

We at Swissbit place great value on the environment and thus pay close attention to the diverse aspects of manufacturing environmentally and health friendly products. The European Parliament and the Council of the European Union have published two Directives defining a European standard for environmental protection. This states that CompactFlash Cards must comply with both Directives in order for them to be sold on the European market:

- **RoHS** – Restriction of Hazardous Substances
- **WEEE** – Waste Electrical and Electronic Equipment

Swissbit would like to take this opportunity to inform our customers about the measures we have implemented to adapt all our products to the European norms.

What is the WEEE Directive (2012/19/EC)?

The Directive covers the following points:

- Prevention of WEEE
- Recovery, recycling and other measures leading to a minimization of wastage of electronic and electrical equipment
- Improvement in the quality of environmental performance of all operators involved in the EEE life cycle, as well as measures to incorporate those involved at the EEE waste disposal points

What are the key elements?

The WEEE Directive covers the following responsibilities on the part of producers:

Producers must draft a disposal or recovery scheme to dispose of EEE correctly.
Producers must be registered as producers in the country in which they distribute the goods.
They must also supply and publish information about the EEE categories.
Producers are obliged to finance the collection, treatment and disposal of WEEE.

Inclusion of WEEE logos on devices

In reference to the Directive, the WEEE logo must be printed directly on all devices that have sufficient space. «In exceptional cases where this is necessary because of the size of the product, the symbol of the WEEE Directive shall be printed on the packaging, on the instructions of use and on the warranty» (WEEE Directive 2012/19/EC)

When does the WEEE Directive take effect?

The Directive came into effect internationally on July 04, 2012.

What is RoHS (2011/65/EU)?

The goals of the Directive are to:

- Place less of a burden on human health and to protect the environment by restricting the use of hazardous substances in new electrical and electronic devices
- To support the WEEE Directive (see above)

RoHS enforces the restriction of the following 6 hazardous substances in electronic and electrical devices:

- Lead (Pb) – no more than 0.1% by weight in homogeneous materials
- Mercury (Hg) – no more than 0.1% by weight in homogeneous materials
- Cadmium (Cd) – no more than 0.01% by weight in homogeneous materials
- Chromium (Cr6+) – no more than 0.1% by weight in homogeneous materials
- PBB, PBDE – no more than 0.1% by weight in homogeneous materials

Swissbit is obliged to minimize the hazardous substances in the products.

According to part of the Directive, manufacturers are obliged to make a self-declaration for all devices with RoHS. Swissbit carried out intensive tests to comply with the self-declaration. We have also already taken steps to have the analyses of the individual components guaranteed by third-party companies.

Swissbit carried out the following steps during the year with the goal of offering our customers products that are fully compliant with the RoHS Directive.

- **Preparing all far-reaching directives, logistical enhancements and alternatives regarding the full understanding and introduction of the RoHS Directive's standards**
- **Checking the components and raw materials:**
 - Replacing non-RoHS-compliant components and raw materials in the supply chain
 - Cooperating closely with suppliers regarding the certification of all components and raw materials used by Swissbit
- **Modifying the manufacturing processes and procedures**
 - Successfully adapting and optimizing the new management-free integration process in the supply chain
 - Updating existing production procedures and introducing the new procedures to support the integration process and the sorting of materials
- **Carrying out the quality process**
 - Performing detailed function and safety tests to ensure the continuous high quality of the Swissbit product line

When does the RoHS Directive take effect?

As of June 08, 2011 only new electrical and electronic devices with approved quantities of RoHS will be put on the market.

When will Swissbit be offering RoHS-approved products?

Swissbit's RoHS-approved products are available now. Please contact your Swissbit contact person to find out more about exchanging your existing products for RoHS-compliant devices.

For your attention

We understand that packaging and accessories are not EEE material and are therefore not subject to the WEEE or RoHS Directives.

Contact details:

Swissbit AG
Industriestrasse 4
CH 9552 Bronschhofen
Tel: +41 71 913 03 03 – Fax: +41 71 913 03 15
E-mail: info@swissbit.com – Website: www.swissbit.com

11 Part Number Decoder

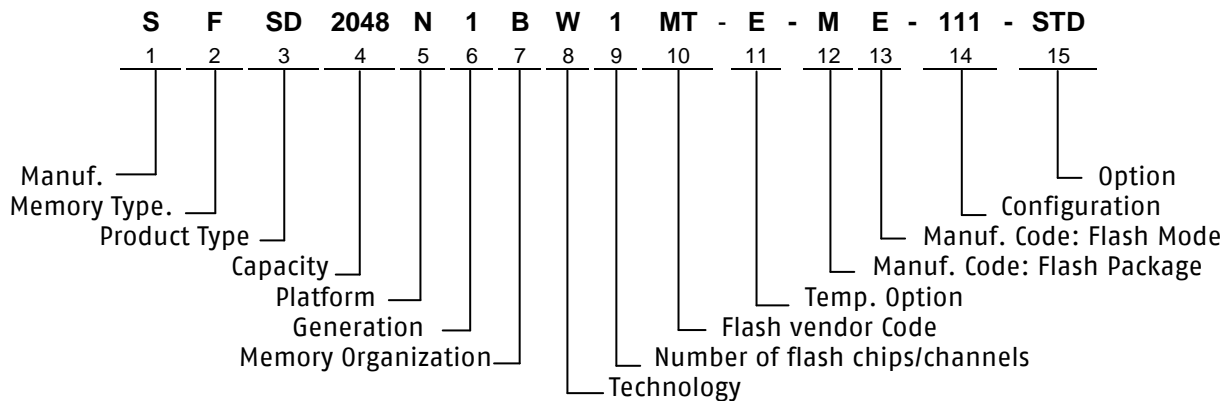

11.1 Manufacturer

Swissbit code	S
---------------	---

11.2 Memory Type

Flash	F
-------	---

11.3 Product Type

SD Memory Card	SD
----------------	----

11.4 Capacity

1 GByte	1024
2 GByte	2048
4 GByte	4096
8 GByte	8192

11.5 Platform

MICRO SD Memory Card	N
----------------------	---

11.6 Generation

Generation	1
------------	---

11.7 Memory Organization

x8	B
----	---

11.8 Technology

SD Memory Card controller	S-3x0 series	W
---------------------------	--------------	---

11.9 Channels

1 Flash Channel	1
-----------------	---

11.10 Flash Code

Micron	MT
--------	----

11.11 Temp. Option

Extended Temp. Range -25°C to 85°C	E
Industrial Temp. Range -40°C to 85°C	I

11.12 DIE Classification

SLC MONO (single die package)	M
SLC DDP (dual die package)	D
SLC QDP (dual die package)	Q
MLC MONO (single die package)	G
MLC DDP (dual die package)	L

11.13 PIN Mode

Single nCE & R/nB	E
Dual nCE & Dual R/nB	F
Quad nCE & Quad R/nB	G

11.14 Configuration XYZ

X → Configuration

Configuration	X
default	1

Y → FW Revision

FW Revision	Y
Version 1	1

Z → optional

Optional	Z
optional	1

11.15 Option

Swissbit / Standard	STD
---------------------	-----

12 Swissbit Label specification

12.1 Front side marking



Swissbit

Density

SD Memory Card logo

12.2 Back side marking



Part Number

Calendar week and year

Lot code

13 Revision History

Table 25: Document Revision History

Date	Revision	Revision Details
April 19, 2012	1.00	Initial release
February 01, 2013	1.01	Electrical characteristic update, added l-grade material, added CE Declaration and gold pads thickness
December 17, 2013	1.10	Changed back side laser marking, 1GB card added, icons added

Disclaimer:

No part of this document may be copied or reproduced in any form or by any means, or transferred to any third party, without the prior written consent of an authorized representative of Swissbit AG ("SWISSBIT"). The information in this document is subject to change without notice. SWISSBIT assumes no responsibility for any errors or omissions that may appear in this document, and disclaims responsibility for any consequences resulting from the use of the information set forth herein. SWISSBIT makes no commitments to update or to keep current information contained in this document. The products listed in this document are not suitable for use in applications such as, but not limited to, aircraft control systems, aerospace equipment, submarine cables, nuclear reactor control systems and life support systems. Moreover, SWISSBIT does not recommend or approve the use of any of its products in life support devices or systems or in any application where failure could result in injury or death. If a customer wishes to use SWISSBIT products in applications not intended by SWISSBIT, said customer must contact an authorized SWISSBIT representative to determine SWISSBIT willingness to support a given application. The information set forth in this document does not convey any license under the copyrights, patent rights, trademarks or other intellectual property rights claimed and owned by SWISSBIT. The information set forth in this document is considered to be "Proprietary" and "Confidential" property owned by SWISSBIT.

ALL PRODUCTS SOLD BY SWISSBIT ARE COVERED BY THE PROVISIONS APPEARING IN SWISSBIT'S TERMS AND CONDITIONS OF SALE ONLY, INCLUDING THE LIMITATIONS OF LIABILITY, WARRANTY AND INFRINGEMENT PROVISIONS. SWISSBIT MAKES NO WARRANTIES OF ANY KIND, EXPRESS, STATUTORY, IMPLIED OR OTHERWISE, REGARDING INFORMATION SET FORTH HEREIN OR REGARDING THE FREEDOM OF THE DESCRIBED PRODUCTS FROM INTELLECTUAL PROPERTY INFRINGEMENT, AND EXPRESSLY DISCLAIMS ANY SUCH WARRANTIES INCLUDING WITHOUT LIMITATION ANY EXPRESS, STATUTORY OR IMPLIED WARRANTIES OF MERCHANTABILITY OR FITNESS FOR A PARTICULAR PURPOSE.

©2014 SWISSBIT AG All rights reserved.