

J-FET INPUT SINGLE OP-AMPS

- LOW POWER CONSUMPTION
- WIDE COMMON-MODE AND DIFFERENTIAL VOLTAGE RANGE
- LOW INPUT BIAS AND OFFSET CURRENT
- OUTPUT SHORT-CIRCUIT PROTECTION
- HIGH INPUT IMPEDANCE J-FET INPUT STAGE
- INTERNAL FREQUENCY COMPENSATION
- LATCH UP FREE OPERATION
- HIGH SLEW RATE : 13 V/ μ s (typ)

DESCRIPTION

These circuits are high speed J-FET input single operational amplifiers incorporating well matched, high voltage J-FET and bipolar transistors in a monolithic integrated circuit.

The devices feature high slew rates, low input bias and offset current, and low offset voltage temperature coefficient.

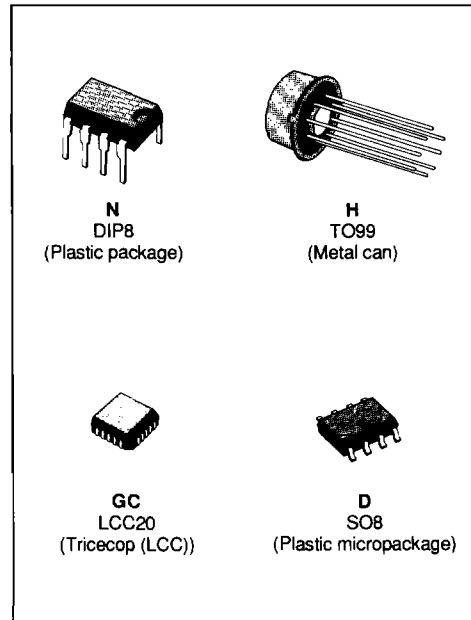

PIN CONNECTIONS (Top views)

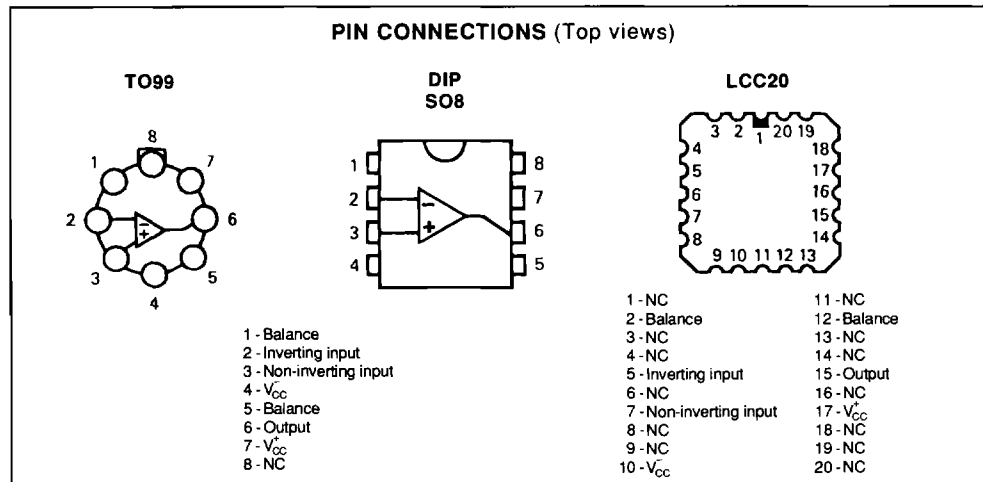

ORDER CODES

Part Number	Temperature	Package
MC35001GC	- 55 °C to + 125 °C	LCC
MC35001AGC	- 55 °C to + 125 °C	LCC
MC35001BGC	- 55 °C to + 125 °C	LCC
MC35001H	- 55 °C to + 125 °C	METAL CAN
MC35001AH	- 55 °C to + 125 °C	METAL CAN
MC35001BH	- 55 °C to + 125 °C	METAL CAN
MC33001N	- 40 °C to + 105 °C	DIP8
MC33001AN	- 40 °C to + 105 °C	DIP8
MC33001BN	- 40 °C to + 105 °C	DIP8
MC33001D	- 40 °C to + 105 °C	SO8
MC33001AD	- 40 °C to + 105 °C	SO8
MC33001BD	- 40 °C to + 105 °C	SO8
MC34001N	0 °C to + 70 °C	DIP8
MC34001AN	0 °C to + 70 °C	DIP8
MC34001BN	0 °C to + 70 °C	DIP8
MC34001D	0 °C to + 70 °C	SO8
MC34001AD	0 °C to + 70 °C	SO8
MC34001BD	0 °C to + 70 °C	SO8

ABSOLUTE MAXIMUM RATINGS

Symbol	Parameter	Value	Unit
V _{CC}	Supply Voltage (note 1)	± 18	V
V _I	Input Voltage (note 3)	± 15	V
V _{CC}	Diff. Input Voltage (note 2)	± 30	V
P _{tot}	Power Dissipation	680	mW
	Output Short-circuit Duration (note 4)	Infinite	
T _{oper}	Operating Free Air Temperature Range	0 to 70 - 40 to 105 - 55 to 125	°C
T _{stg}	Storage Temperature Range	- 65 to 150	°C

- Notes :**
1. All voltage values, except differential voltage, are with respect to the zero reference level (ground) of the supply voltages where the zero reference level is the midpoint between V_{CC} and V_{CC}.
 2. Differential voltages are at the non-inverting input terminal with respect to the inverting input terminal.
 3. The magnitude of the input voltage must never exceed the magnitude of the supply voltage or 15 volts, whichever is less.
 4. The output may be shorted to ground or to either supply. Temperature and /or supply voltages must be limited to ensure that the dissipation rating is not exceeded.

SCHEMATIC DIAGRAM

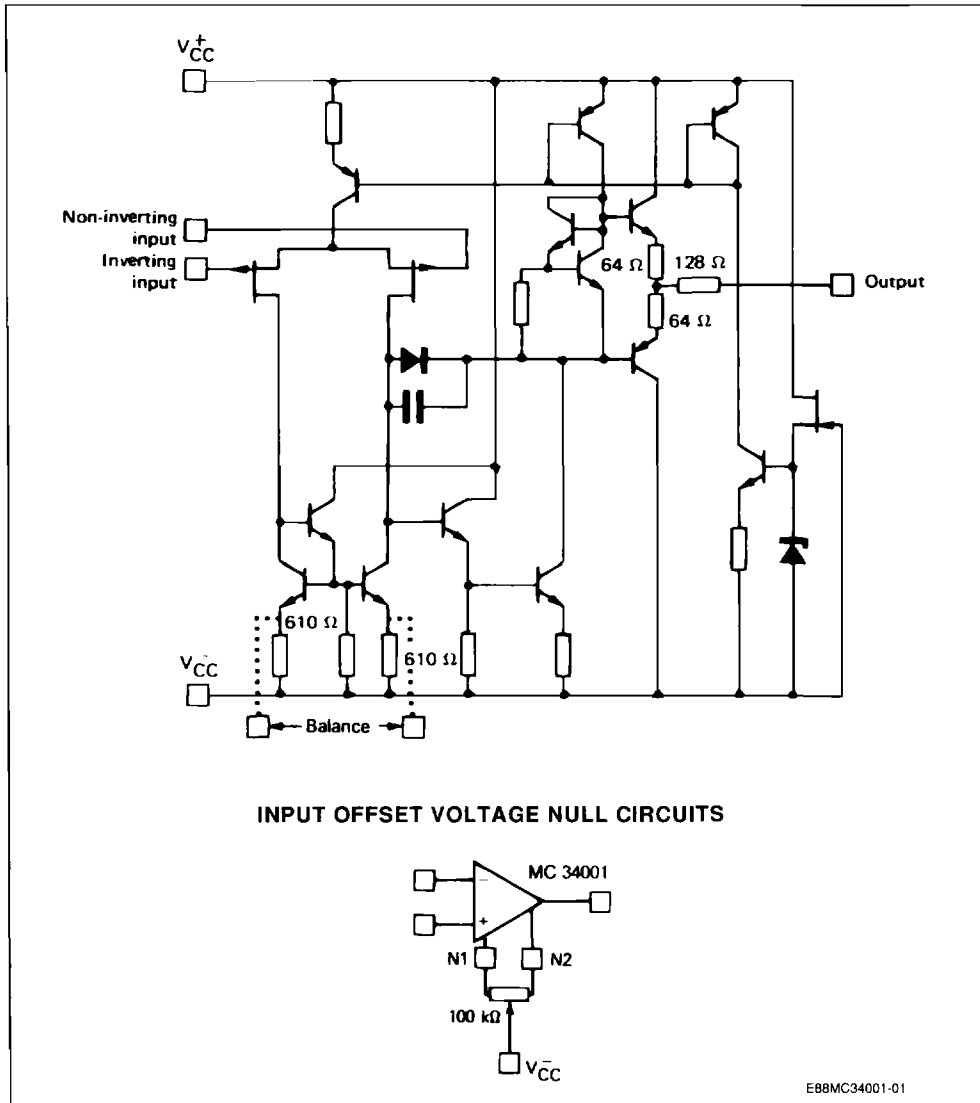

Case	Balance	Inverting Input	Non-inverting Input	Output	V _{CC} ⁺	V _{CC} ⁻	N.C.
DIP8 SO8 TO99	1, 5	2	3	6	7	4	8
LCC20	2, 12	5	7	15	17	10	*

* LCC20 : Other pins are not connected.

ELECTRICAL CHARACTERISTICS

$V_{CC} = \pm 15\text{ V}$ (unless otherwise specified)

MC35001, MC35001A, MC35001B $-55 \leq T_{amb} \leq +125\text{ }^\circ\text{C}$

MC33001, MC33001A, MC33001B $-40 \leq T_{amb} \leq +105\text{ }^\circ\text{C}$

MC34001, MC34001A, MC34001B $0 \leq T_{amb} \leq +70\text{ }^\circ\text{C}$

Symbol	Parameter	MC35001A, B MC33001A, B MC34001A, B			MC35001 MC33001 MC34001			Unit
		Min.	Typ.	Max.	Min.	Typ.	Max.	
V_{IO}	Input Offset Voltage $T_{amb} = 25\text{ }^\circ\text{C}$ ($R_S < 10\text{ k}\Omega$) MC35001B, MC34001B, MC33001B MC35001A, MC34001A, MC33001A $T_{min} \leq T_{amb} \leq T_{max}$ MC35001B, MC34001B, MC33001B MC35001A, MC34001A, MC33001A		3 0.2	5 1		3 8	13	mV
DV_{IO}	Input Offset Voltage Drift		10			10		$\mu\text{V}/^\circ\text{C}$
I_{IO}	Input Offset Current * $T_{amb} = 25\text{ }^\circ\text{C}$ $T_{min} \leq T_{amb} \leq T_{max}$		5	50 4		5 50 4		μA nA
I_{IB}	Input Bias Current * $T_{amb} = 25\text{ }^\circ\text{C}$ $T_{min} \leq T_{amb} \leq T_{max}$		20	200 20		20 200 20		μA nA
A_{VD}	Large Signal Voltage Gain ($R_L > 2\text{ k}\Omega$, $V_o = \pm 10\text{ V}$) $T_{amb} = 25\text{ }^\circ\text{C}$ $T_{min} \leq T_{amb} \leq T_{max}$	50 25	200		50 25	200		V/mV
SVR	Supply Voltage Rejection Ratio ($R_S < 10\text{ k}\Omega$) $T_{amb} = 25\text{ }^\circ\text{C}$ $T_{min} \leq T_{amb} \leq T_{max}$	80 80	86		80 80	86		dB
I_{CC}	Supply Current, No Load $T_{amb} = 25\text{ }^\circ\text{C}$ $T_{min} \leq T_{amb} \leq T_{max}$		1.4	2.5 2.5		1.4 2.5 2.5		mA
V_I	Input Voltage Range $T_{amb} = 25\text{ }^\circ\text{C}$ $T_{min} \leq T_{amb} \leq T_{max}$	- 11		+ 11	- 11		+ 11	V
CMR	Common Mode Rejection Ratio ($R_S < 10\text{ k}\Omega$) $T_{amb} = 25\text{ }^\circ\text{C}$ $T_{min} \leq T_{amb} \leq T_{max}$	80 80	86		70 70	86		dB
I_{OS}	Output Short-circuit Current $T_{amb} = 25\text{ }^\circ\text{C}$ $T_{min} \leq T_{amb} \leq T_{max}$	10 10	40	60 60	10 10	40 60 60		mA
$\pm V_{OPP}$	Output Voltage Swing $T_{amb} = 25\text{ }^\circ\text{C}$ $T_{min} \leq T_{amb} \leq T_{max}$		$R_L \geq 2\text{ k}\Omega$ $R_L \geq 10\text{ k}\Omega$ $R_L \geq 2\text{ k}\Omega$ $R_L \geq 10\text{ k}\Omega$	11 12 13.5 11 12		11 12 13.5 11 12		V
S_{VO}	Slew-rate ($V_I = 10\text{ V}$, $R_L = 2\text{ k}\Omega$) $C_L \leq 100\text{ pF}$, $T_{amb} = 25\text{ }^\circ\text{C}$, unity gain	12	16		12	16		V/ μs

* The input bias currents are junction leakage currents which approximately double for every 10 °C increase in the junction temperature.

ELECTRICAL CHARACTERISTICS (continued)

Symbol	Parameter	MC34001A, B MC33001A, B MC35001A, B			MC34001 MC33001 MC35001			Unit
		Min.	Typ.	Max.	Min.	Typ.	Max.	
t_r	Rise Time ($V_i = 20$ mV, $R_L = 2$ k Ω) $C_L = 100$ pF, $T_{amb} = 25$ °C, unity gain		0.1		0.1			μ s
K_{OV}	Overshoot ($V_i = 20$ mV, $R_L = 2$ k Ω) $C_L \leq 100$ pF, $T_{amb} = 25$ °C, unity gain)		10		10			%
GBP	Gain Bandwidth Product ($f = 100$ kHz, $T_{amb} = 25$ °C $V_{IN} = 10$ mV, $R_L = 2$ k Ω , $C_L = 100$ pF)	3.3	4.0	5.0	3.3	4.0	5.0	MHz
R_i	Input Resistance ($T_{amb} = 25$ °C)		10^{12}		10^{12}			Ω
THD	Total Harmonic Distortion ($f = 1$ kHz, $A_V = 20$ dB, $R_L = 2$ K Ω) $C_L \leq 100$ pF, $T_{amb} = 25$ °C, $V_O = 2$ V _{PP})		0.01		0.01			%
V_n	Equivalent Input Noise Voltage ($f = 1$ kHz, $R_g = 100$ Ω)		15		15			nV/ \sqrt{Hz}
ϕ_m	Phase Margin		45		45			Degrees

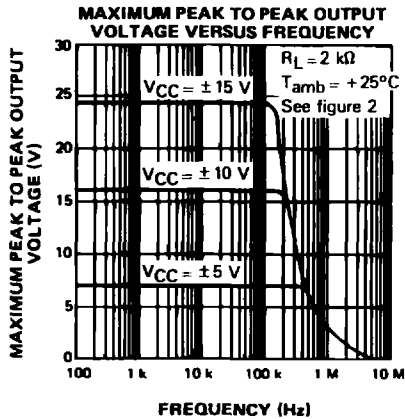

E88MC34001-02

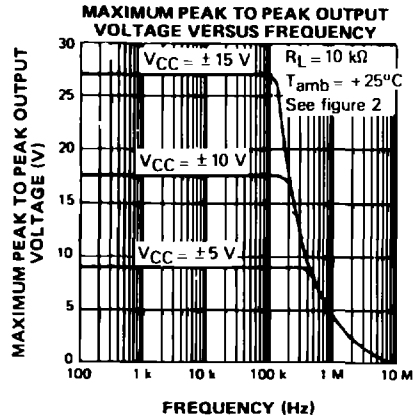

E88MC34001-03

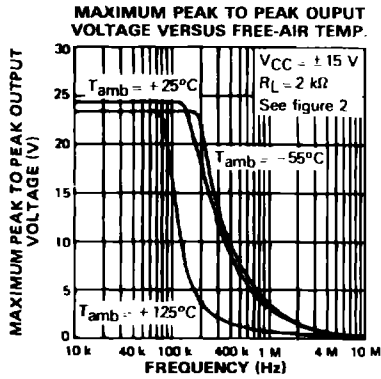

E88MC34001-04

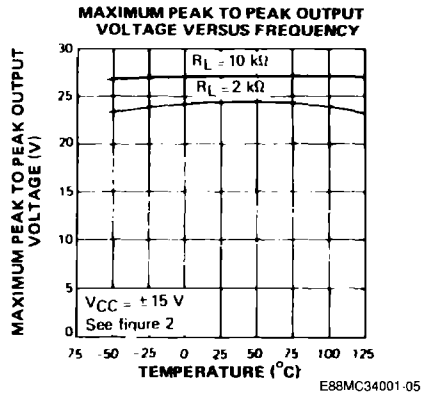

E88MC34001-05

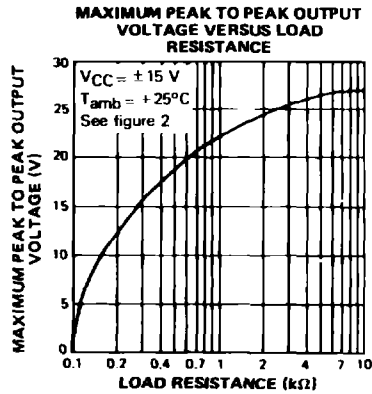

E88MC34001-06

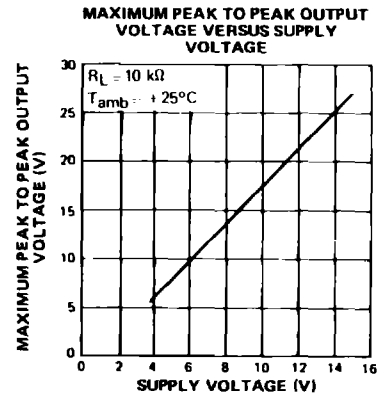

E88MC34001-07

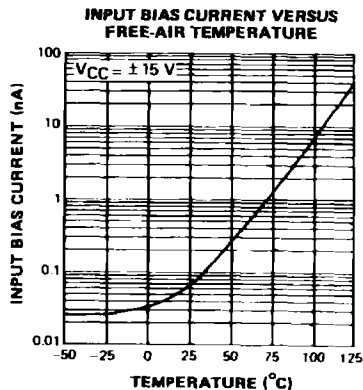

E88MC34001-08

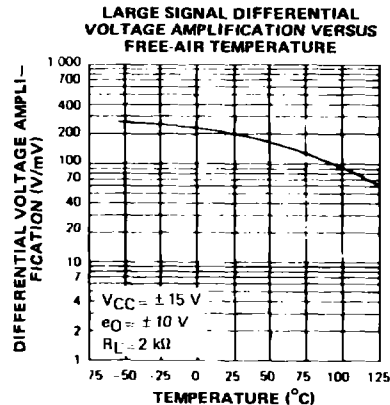

E88MC34001-09

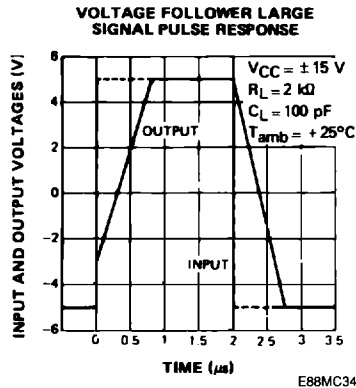
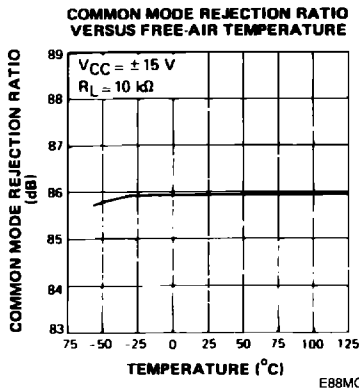
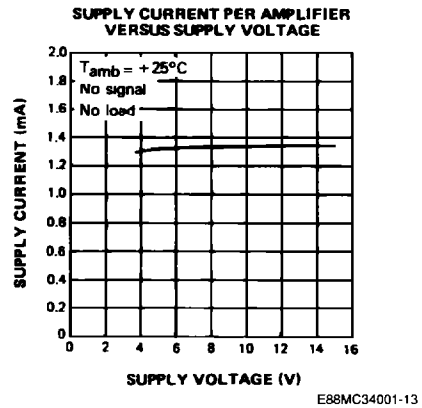
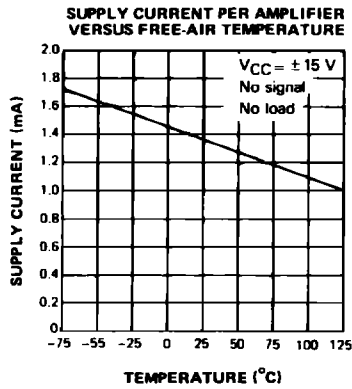
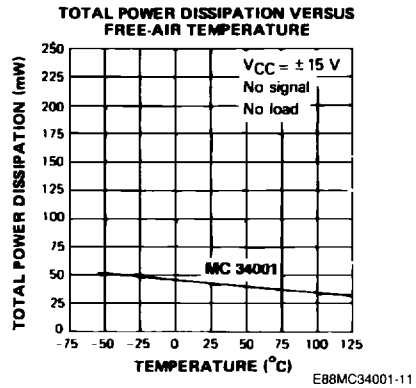
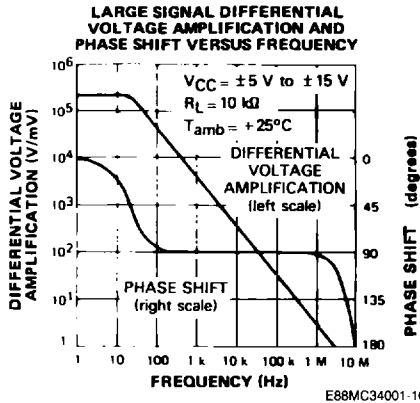

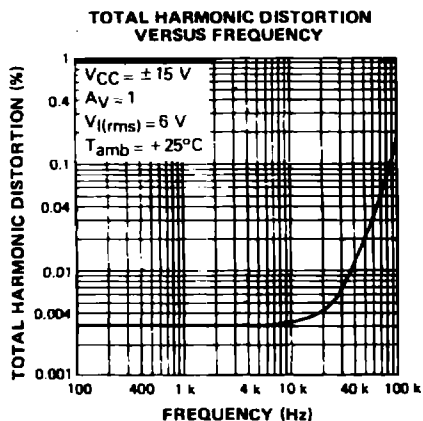
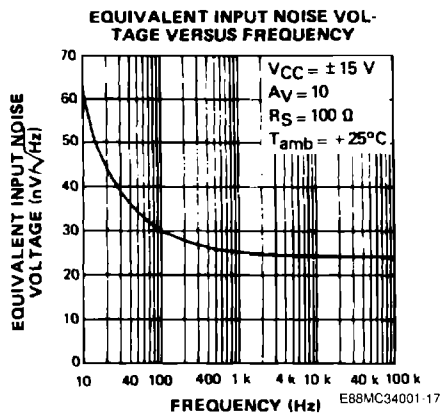
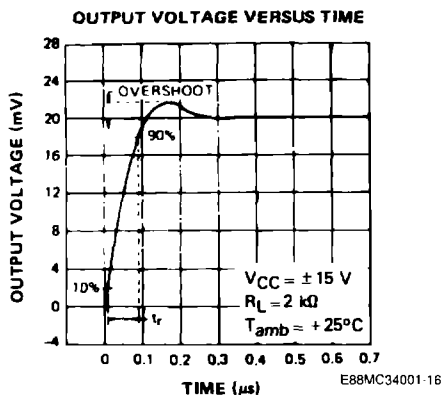

PARAMETER MEASUREMENT INFORMATION

Figure 1 : Voltage Follower.

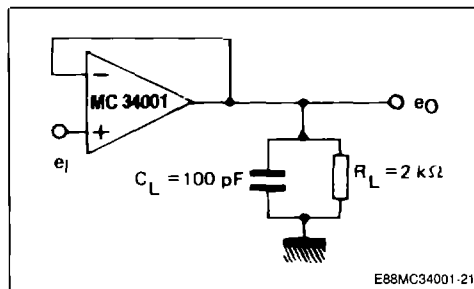
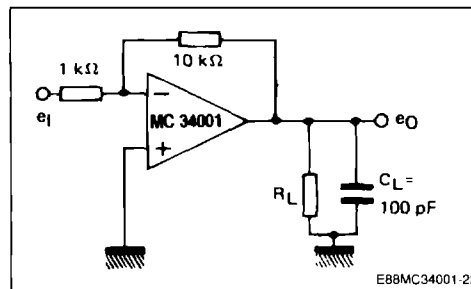
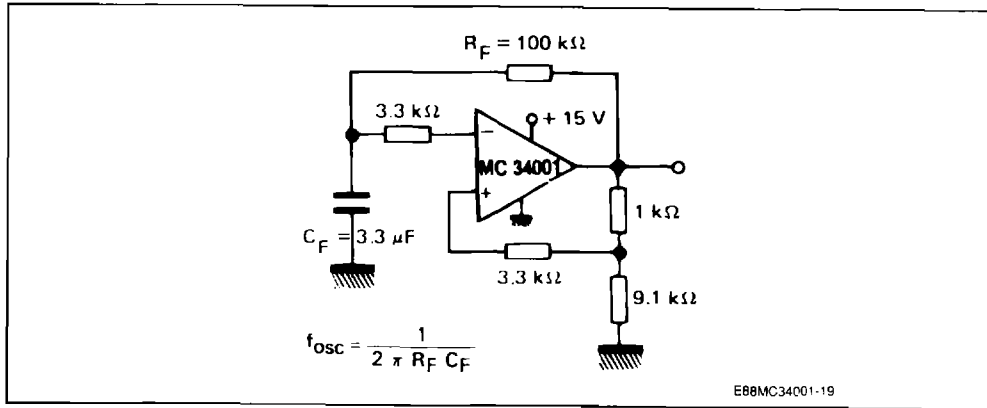

Figure 2 : Gain-of-10 Inverting Amplifier.



TYPICAL APPLICATIONS

(0.5 Hz) SQUARE WAVE OSCILLATOR



HIGH Q NOTCH FILTER

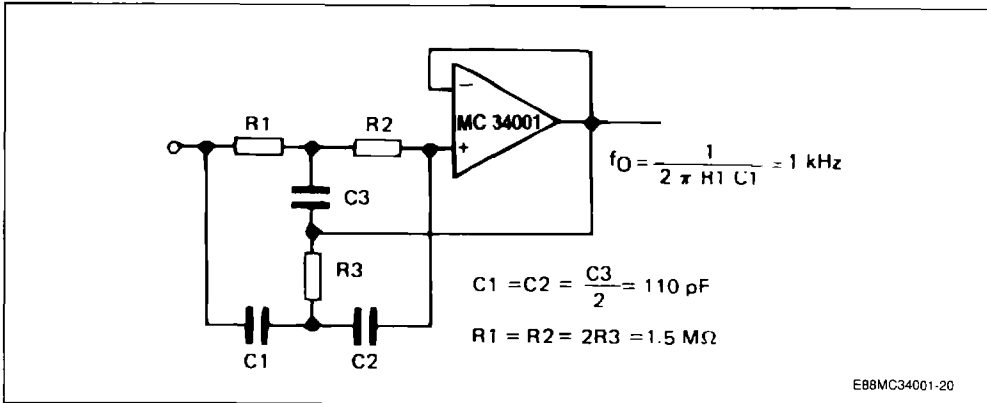

PACKAGE MECHANICAL DATA

8 PINS – PLASTIC DIP

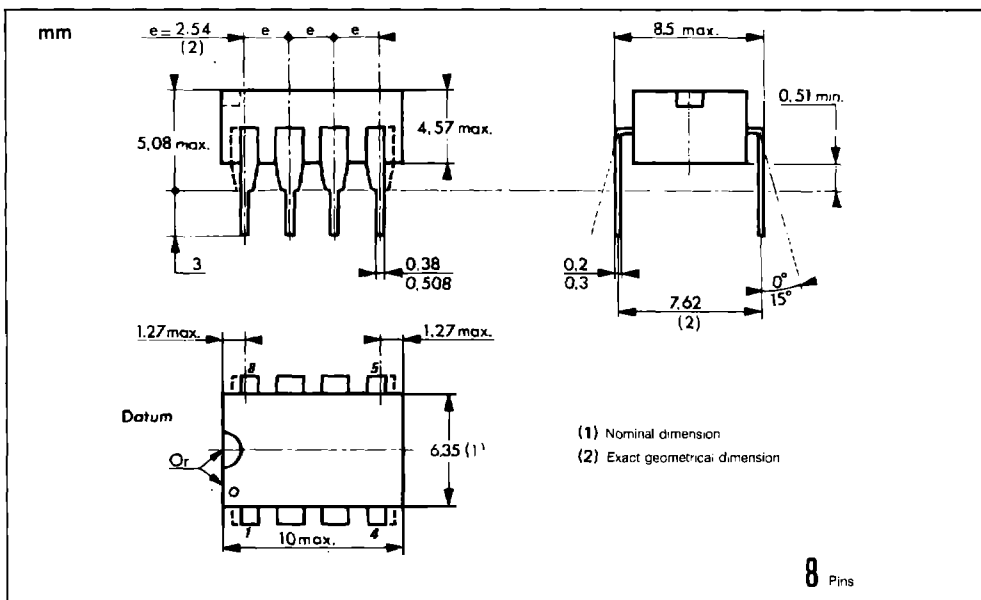

8 PINS – PLASTIC MICROPACKAGE (SO)

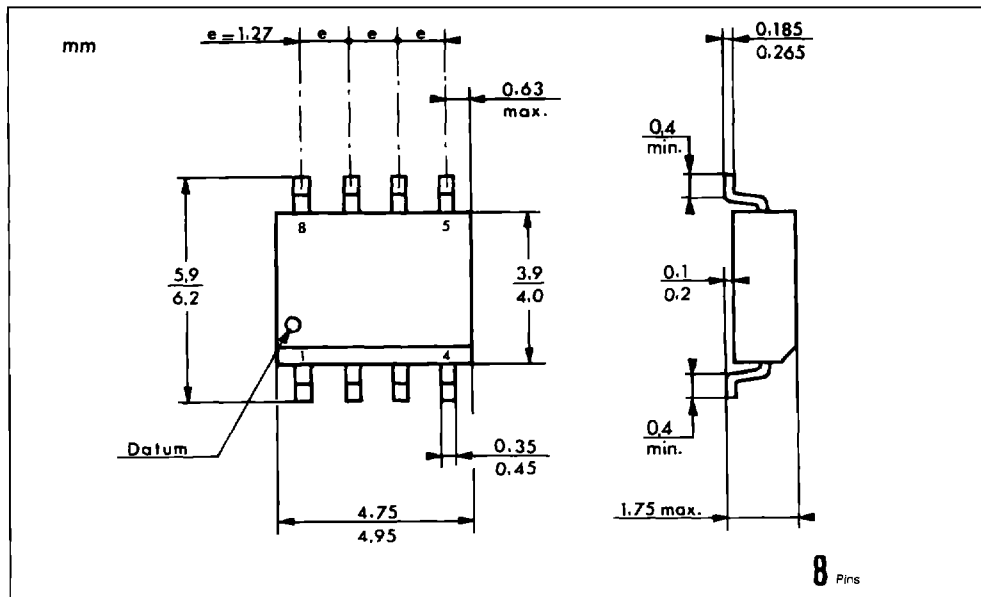

TO99 – METAL CAN

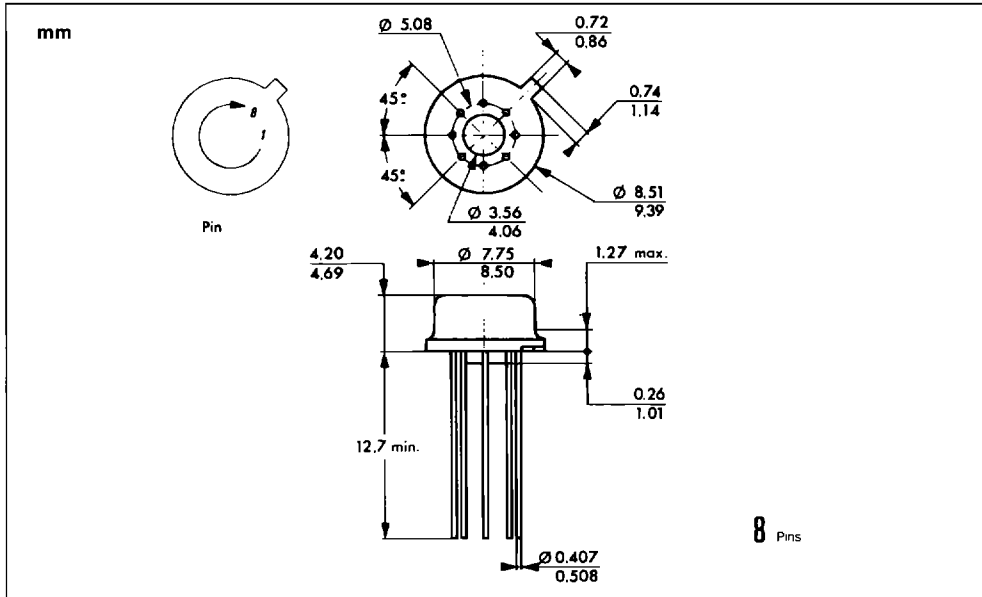

20 PINS – TRICECOP (LCC)

