

BAR65V-02V

■ Features

- Space saving SOD523 package with low series inductance
- Very small reverse capacitance
- Small reverse capacitance

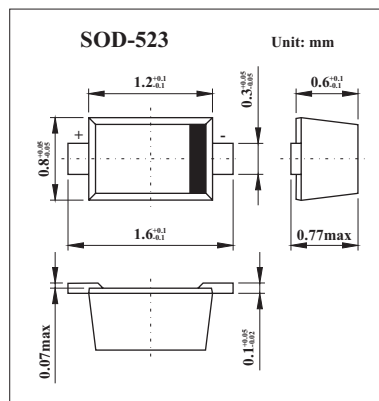

■ Absolute Maximum Ratings Ta = 25°C

Parameter	Symbol	Value	Unit
Reverse voltage	V _R	30	V
Forward current	I _F	100	mA
Junction temperature	T _j	150	°C
Storage temperature	T _{stg}	-55 to +150	°C
Junction soldering point	R _{thJS}	100	K/W

■ Electrical Characteristics Ta = 25°C

Parameter	Symbol	Test Condition	Min	Typ	Max	Unit
Reverse voltage	V _R	I _R = 10 μA	30			V
Reverse current	I _R	V _R = 20 V			20	nA
Forward voltage	V _F	I _F = 100 mA			1.1	V
Diode capacitance	C _D	f = 1 MHz, V _R = 0		0.65		pF
		f = 1 MHz, V _R = 1 V		0.55	0.9	
		f = 1 MHz, V _R = 3 V		0.50	0.8	
Forward resistance	r _f	f = 100 MHz, I _F = 1 mA		1		Ω
		f = 100 MHz, I _F = 5 mA		0.6	0.95	
		f = 100 MHz, I _F = 10 mA		0.52	0.9	
Charge carrier life time	t _{rr}	I _F = 10 mA, I _R = 6 mA, i _R = 3 mA		150		ns

■ Marking

Marking	E
---------	---