

# Photologic® Slotted Optical Switch OPB960, OPB970, OPB980, OP990 Series

For parts built after 2004



## Features:

- Data rates to 250 kBaud
- 24" minimum 26 AWG wire leads
- Choice of output configuration
- Choice of opaque or IR-transmissive shell material
- Choice of aperture
- Choice of mounting configuration

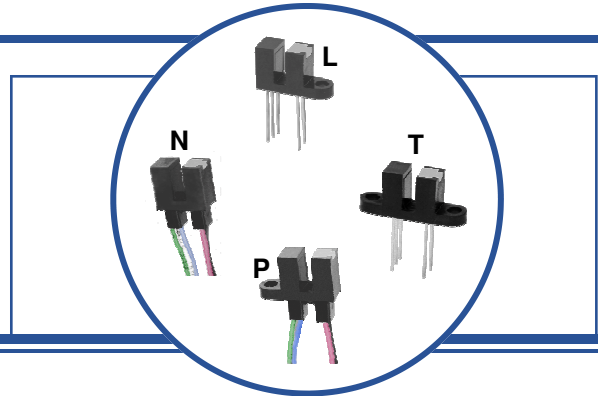

## Description:

The **OPB960, OPB970, OPB980** and **OPB990** series of Photologic® photo integrated circuit switches provide optimum flexibility for the design engineer. Building from a standard housing with a 0.125" (3.180 mm) wide slot, a user can specify the type and polarity of TTL output, discrete shell material, aperture width and choice of mounting configurations. **OPB960** through **OPB973** have 0.425" (10.795 mm) PCBoard leads with 0.320" (8.1 mm) spacing. **OPB980** through **OPB993** have 24" (609 mm) 26 AWG wires.

All devices in this series exhibit performance over supply voltages ranging from 4.5 V to 16.0 V, and may be specified as buffered or inverted with Totem-Pole or Open Collector output. Devices are also TTI/LSTTL compatible and can drive up to 10 TTL loads.

Custom electrical, wire and cabling and connectors are available. Contact your local representative or OPTEK for more information.

## Applications:

- Mechanical switch replacement
- Mechanical limit indication
- Edge sensing
- Speed and direction indication
- Rotary encoders
- Sliding Door Automotive and Liftgate applications

## Part Number Guide — OPB980 and OPB990 Series

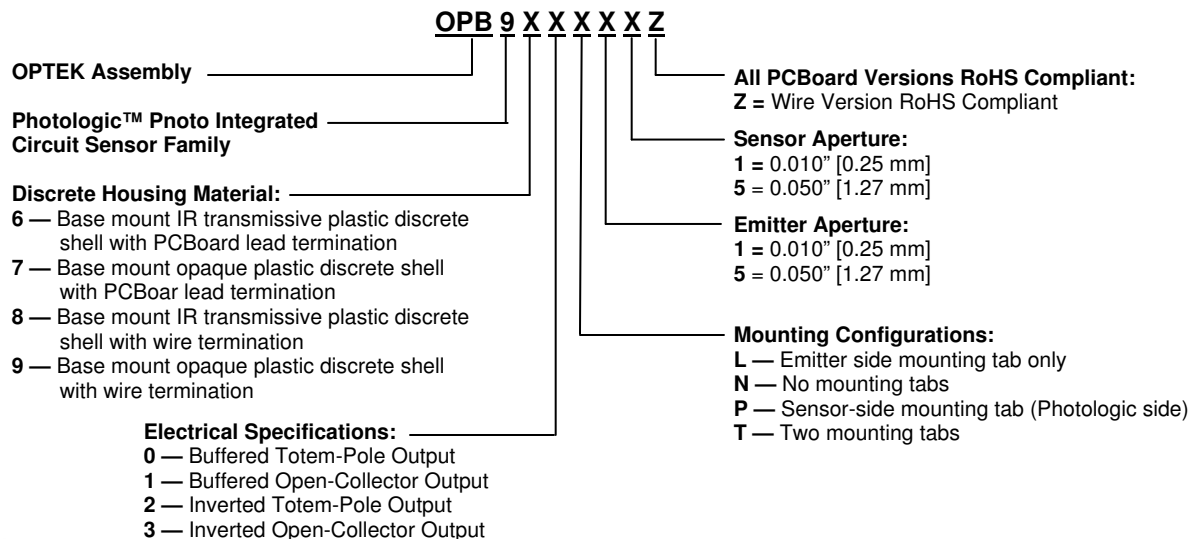

**RoHS**

OPTEK Technology is TS 16949:2002 certified, any changes will be consistent with TS 16949:2002 procedures.

# Photologic® Slotted Optical Switch OPB960, OPB970, OPB980, OP990 Series

For parts built after 2004



## OP960, OP970 Series

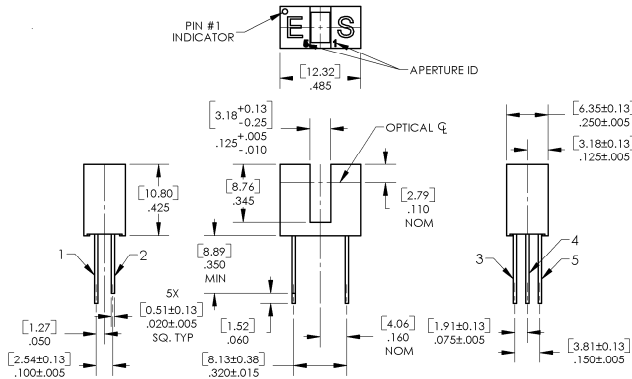

Color-Pin	Description
Red-1	Anode
Black-2	Cathode
Green-5	Ground
Blue-4	Output
White-3	Vcc

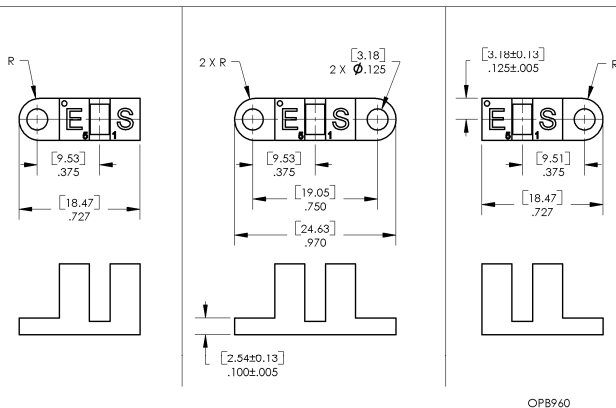

DIMENSIONS ARE IN: [MILLIMETERS]  
INCHES

## OP980, OP990 Series

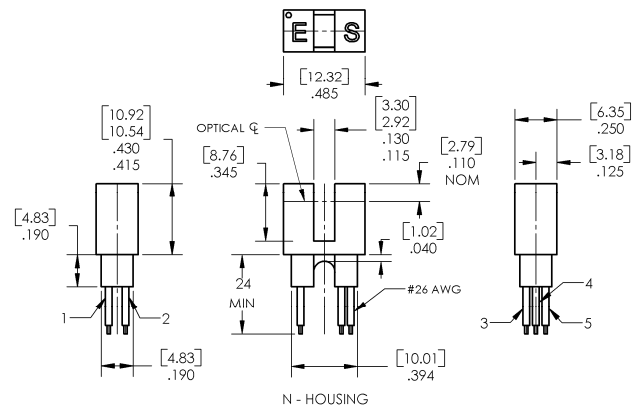

**CONTAINS POLYSULFONE**  
To avoid stress cracking, we suggest using ND Industries' **Vibra-Tite** for thread-locking. **Vibra-Tite** evaporates fast without causing structural failure in OPTEK's molded plastics.  
**Applies to: OPB460, OPB470, OPB480, OPB490.**

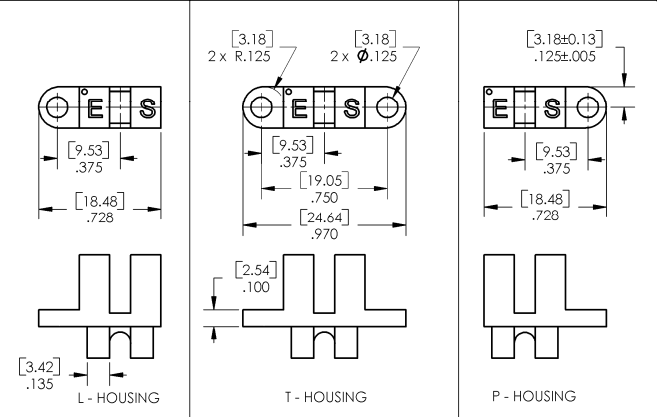

OPTEK Technology is TS 16949:2002 certified, any changes will be consistent with TS 16949:2002 procedures.

**Totem-Pole-Output**

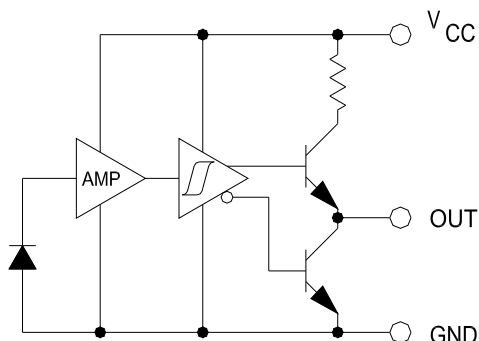

**Open-Collector-Output**

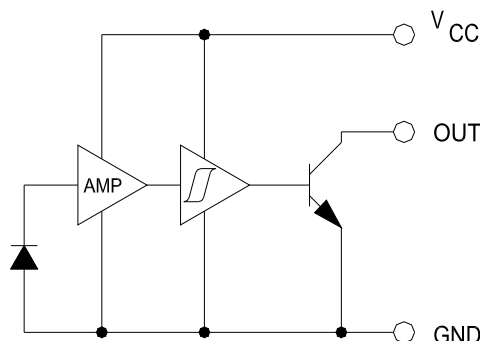

**Inverted Totem-Pole**

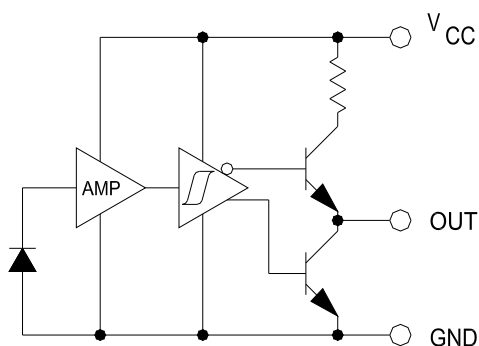

**Inverted Open Collector**

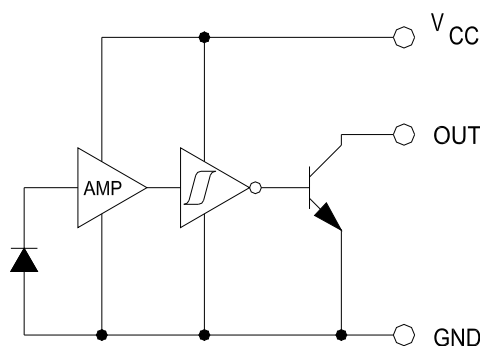

**Absolute Maximum Ratings** ( $T_A=25^\circ\text{C}$  unless otherwise noted)

Storage Temperature Range	-40 °C to +85 °C
Operating Temperature Range	-40 °C to +70 °C
Supply Voltage $V_{CC}$ (not to exceed 3 seconds)	18 V
Input Diode Power Dissipation	100 mW <sup>(1)</sup>
Output Photologic™ Power Dissipation	200 mW <sup>(2)</sup>
Total Device Power Dissipation	300 mW <sup>(3)</sup>
Voltage at Output Lead (Open Collector Output)	35V
Diode Forward D.C. Current	40 mA
Diode Reverse D.C. Voltage	2 V

Notes:

- (1) Derate linearly 2.22 mW/°C above 25 °C.
- (2) Derate linearly 4.44 mW/°C above 25 °C.
- (3) Derate linearly 6.66 mW/°C above 25 °C.

OPTEK Technology is TS 16949:2002 certified, any changes will be consistent with TS 16949:2002 procedures.

# Photologic® Slotted Optical Switch

## OPB960, OPB970, OPB980, OP990 Series

For parts built after 2004



### Electrical Characteristics ( $T_A = -40^\circ\text{C}$ to $+70^\circ\text{C}$ , $V_{CC} = 4.5\text{V}$ to $16.0\text{V}$ unless otherwise noted)

SYMBOL	PARAMETER	MIN	TYP	MAX	UNITS	TEST CONDITIONS
--------	-----------	-----	-----	-----	-------	-----------------

#### Input Diode (See OP240 for additional information)

$V_F$	Forward Voltage	-	-	1.7	V	$I_F = 20\text{ mA}$ , $T_A = 25^\circ\text{C}$
$I_R$	Reverse Current	-	-	100	$\mu\text{A}$	$V_R = 2.0\text{ V}$ , $T_A = 25^\circ\text{C}$

#### Output Photologic® Sensor (See OPL560 series for additional information)

$V_{CC}$	Operating D.C. Supply Voltage	4.5	-	16.0	V	-
$V_{R(P-P)}$	Peak-to-Peak $V_{CC}$ voltage ripple necessary to cause false triggering	-	-	2.0	V	$f = \text{DC to } 50\text{ MHz}$
$I_{CC}$	Supply Current	-	8	12	mA	$V_{CC} = 4.5\text{V to } 16.0\text{V}$
$V_{OL}$	Low Level Supply Voltage: Totem-Pole Open-Collector Inverted Totem-Pole Inverted Open-Collector	-	-	0.4	V	$I_{OL} = 12.8\text{ mA}$ , $I_F = 0\text{ mA}$ $I_{OL} = 12.8\text{ mA}$ , $I_F = 0\text{ mA}$ $I_{OL} = 12.8\text{ mA}$ , $I_F = 15\text{ mA}^{(5)}$ $I_{OL} = 12.8\text{ mA}$ , $I_F = 15\text{ mA}^{(5)}$
$V_{OH}$	High Level Output Current: Totem-Pole Open-Collector Inverted Totem-Pole Inverted Open-Collector	$V_{CC}-2.1$	-	-	V	$I_{OH} = -1\ \mu\text{A}$ , $I_F = 15\text{ mA}$ $I_{OH} = -1\ \mu\text{A}$ , $I_F = 15\text{ mA}$ $I_{OH} = -1\ \mu\text{A}$ , $I_F = 0\text{ mA}^{(5)}$ $I_{OH} = -1\ \mu\text{A}$ , $I_F = 0\text{ mA}^{(5)}$
$I_{OH}$	High Level Output Current: Totem-Pole Open-Collector Inverted Totem-Pole Inverted Open-Collector	-	-	100	$\mu\text{A}$	$V_{OH} = 30\text{ V}$ , $I_F = 15\text{ mA}$ , $T_A = 25^\circ\text{C}$ $V_{OH} = 30\text{ V}$ , $I_F = 15\text{ mA}$ , $T_A = 25^\circ\text{C}$ $V_{OH} = 30\text{ V}$ , $I_F = 0\text{ mA}^{(5)}$ , $T_A = 25^\circ\text{C}$ $V_{OH} = 30\text{ V}$ , $I_F = 0\text{ mA}^{(5)}$ , $T_A = 25^\circ\text{C}$
$I_F(+)$	LED Positive-Going Threshold Current	-	-	15	mA	$V_{CC} = 5.0\text{ V}$ , $T_A = 25^\circ\text{C}$
$I_F(+)$ , $I_F(-)$	Hysteresis	-	2.0	-	V	$V_{CC} = 5.0\text{ V}$
$I_{OS}$	Short Circuit Output Current: Totem-Pole Inverted Totem-Pole	-15	-	-60	mA	$V_{CC} = 5.25\text{ V}$ , $I_F = 15\text{ mA}$ , $V_{OH} = \text{GND}$ $V_{CC} = 5.25\text{ V}$ , $I_F = 0\text{ mA}^{(5)}$ , $V_{OH} = \text{GND}$
$t_r, t_f$	Output Rise Time, Output Fall Time	-	70	-	ns	$V_{CC} = 5\text{ V}$ , $T_A = 25^\circ\text{C}$ , $I_F = 0$ or $15\text{ mA}$
$T_{PLH}$ , $T_{PHL}$	Propagation Delay Low-High, Propagation High-Low	-	5.0	-	$\mu\text{s}$	$R_L = 8\text{ TTL loads (Totem Pole)}$ , $R_L = 360\ \Omega$ (Open-Collector)

#### Notes:

- (1) The OPB880/OPB890 series switches are terminated with 24" (609.600 mm) of 7-strand 26 AWG, UL 1429 insulated wire on each terminal. Insulation colors and functions are: Anode (red), cathode (black),  $V_{CC}$  (white), output (blue), and ground (green). Custom wire lengths and/or colors are available. Contact your local representative or OPTEK for details.
- (2) Normal application would be with light source blocked, simulated by  $I_F = 0\text{ mA}$ .
- (3) All parameters are tested using pulse techniques.

OPTEK Technology is TS 16949:2002 certified, any changes will be consistent with TS 16949:2002 procedures.

**"55" Aperture - Flag Next to Emitter**

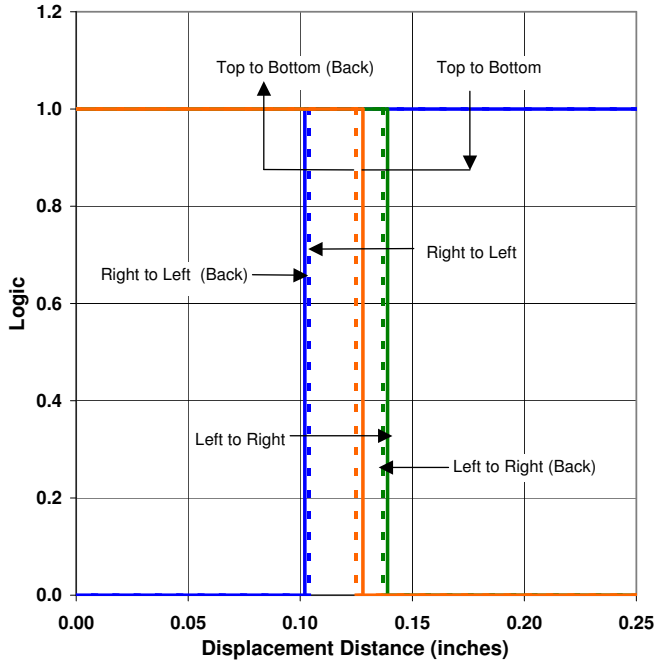

**"55" Aperture - Flag Next to Sensor**

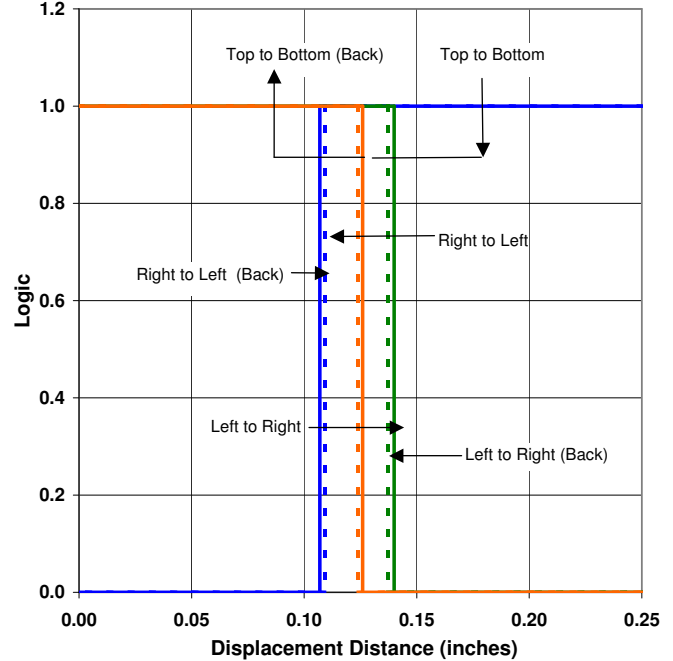

**"55" Aperture - Flag in Middle of Slot**

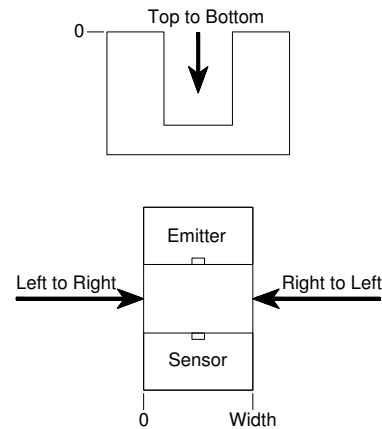
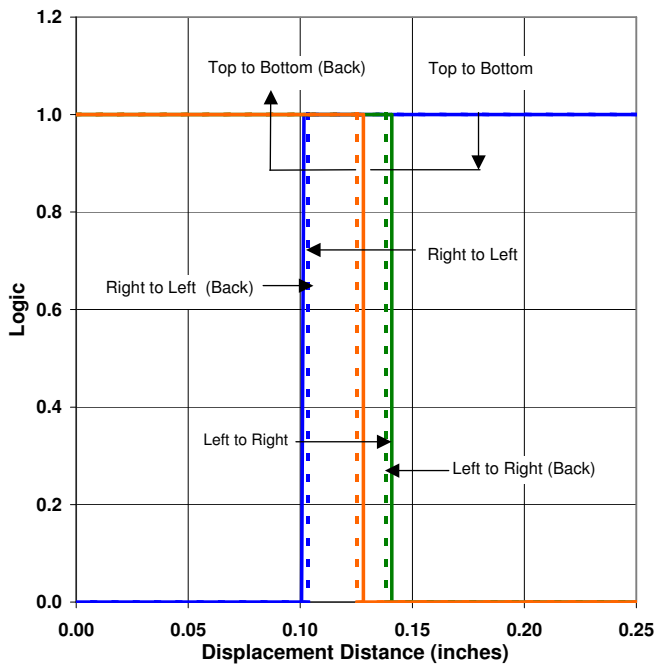

OPTEK Technology is TS 16949:2002 certified, any changes will be consistent with TS 16949:2002 procedures.

**"51" Apertures - Flag Next to Emitter**

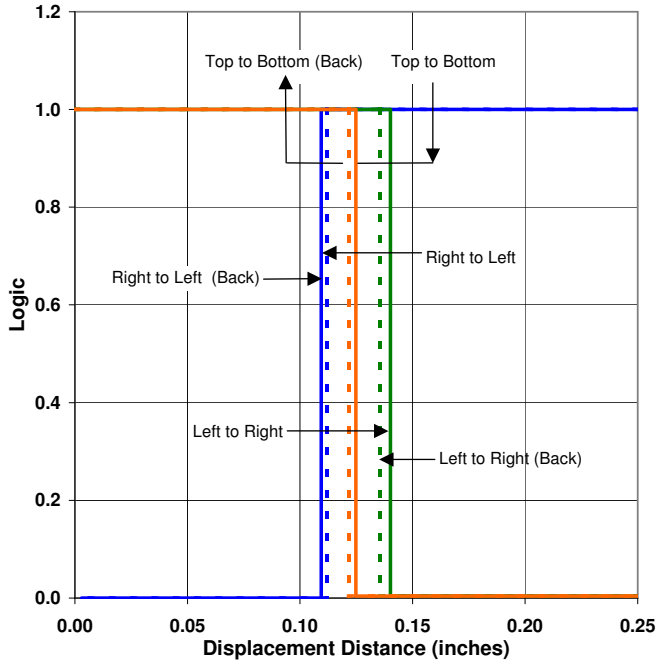

**"51" Aperture - Flag Next to Sensor**

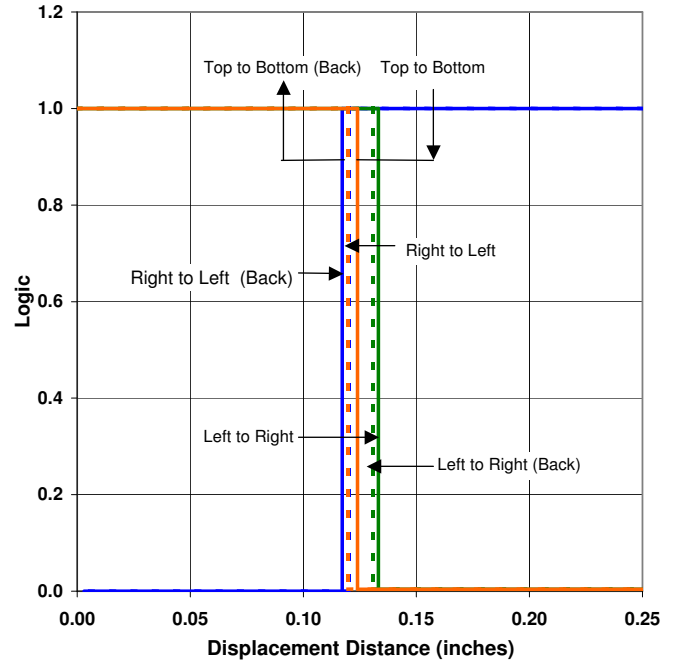

**"51" Aperture - Flag in Middle of Slot**

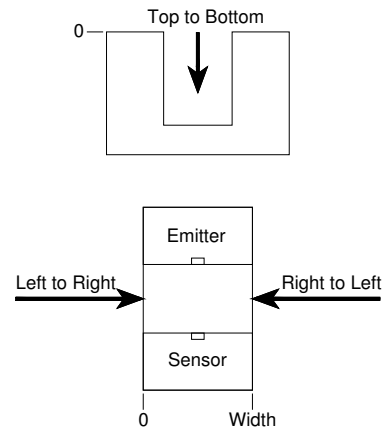
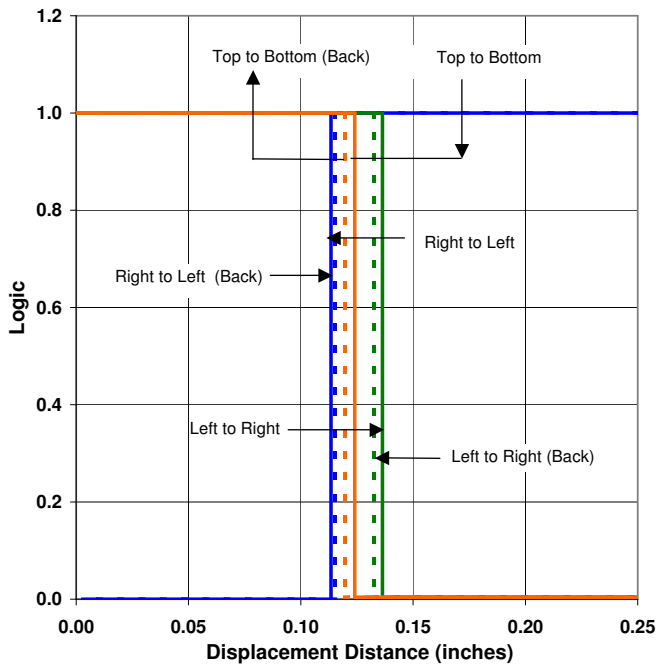

OPTEK Technology is TS 16949:2002 certified, any changes will be consistent with TS 16949:2002 procedures.

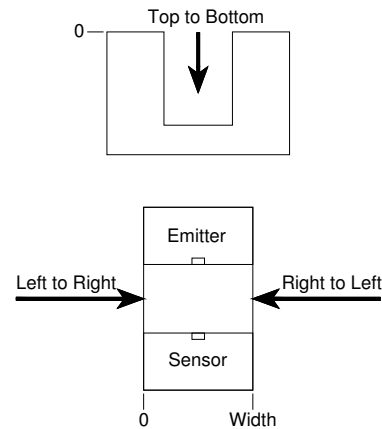
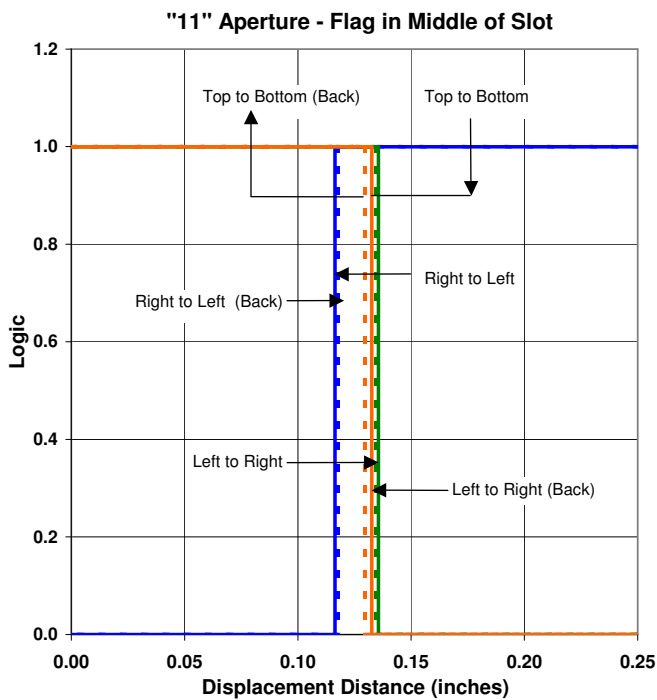
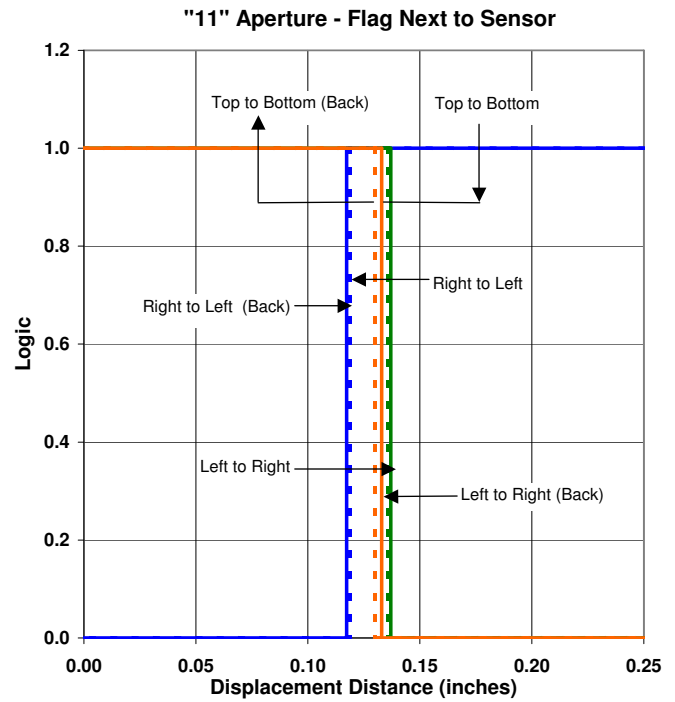
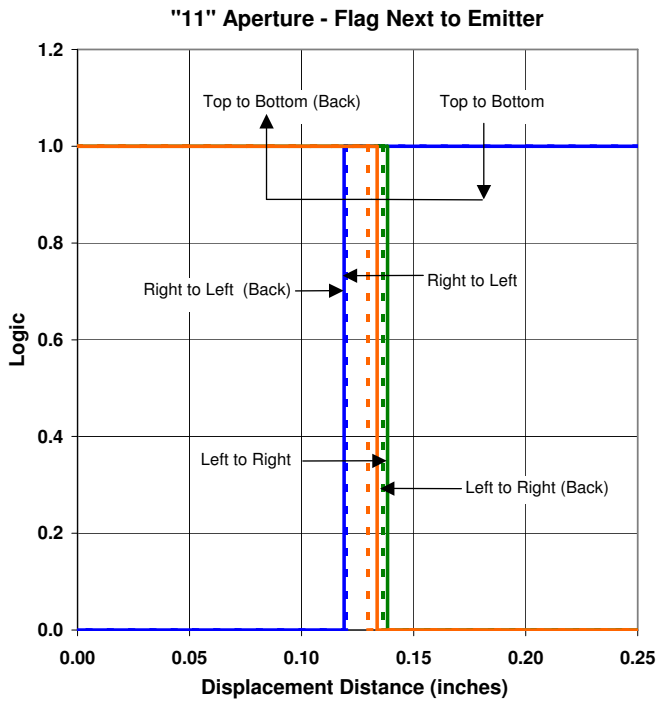

OPTEK Technology is TS 16949:2002 certified, any changes will be consistent with TS 16949:2002 procedures.