

Features

- **78mW High Side MOSFET**
- **Soft Start Time Programmable by External Capacitor**
- **Wide Supply Voltage Range: 4.5V to 24V**
- **Current Limit Protections**
- **Under Voltage Lockout Protection**
- **Over-temperature Protection**
- **Logic Level Enable Input**
- **Lead Free and Green Devices Available (RoHS Compliant)**
- **Current Limit setting**

Applications

- **TFT LCD Modules**
- **Notebook and Desktop Computers**
- **USB Ports**
- **High-side Power Protection Switches**

General Description

The APL3546A is a power-distribution switch with some protection functions. The device incorporates a 78mΩ N-channel MOSFET power switch that is controlled by an enable logic pin and has a SS pin dedicated to soft start ramp-up rate control that can be used in application where the inrush current is concerned.

The device integrates some protection features, including current limit protection, over-temperature protection, UVLO and current limit setting. The current limit protection can protect down-stream devices from catastrophic failure by limiting the output current at current limit threshold during over-load or short circuit events. The over-temperature protection function shuts down IC when the junction temperature rises beyond 150°C. The UVLO function keeps the power switch in off state until there is a valid input voltage present. The current limit can be set by connecting resistor from the current limit adjustable pin ISET to ground.

Simplified Application Circuit

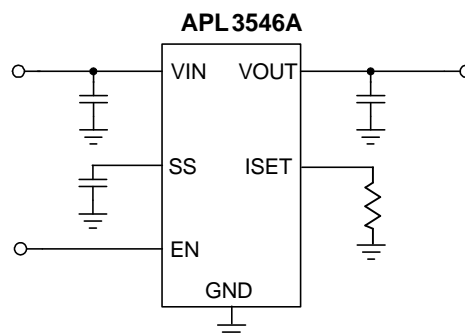

ANPEC reserves the right to make changes to improve reliability or manufacturability without notice, and advise customers to obtain the latest version of relevant information to verify before placing orders.

Pin Configuration

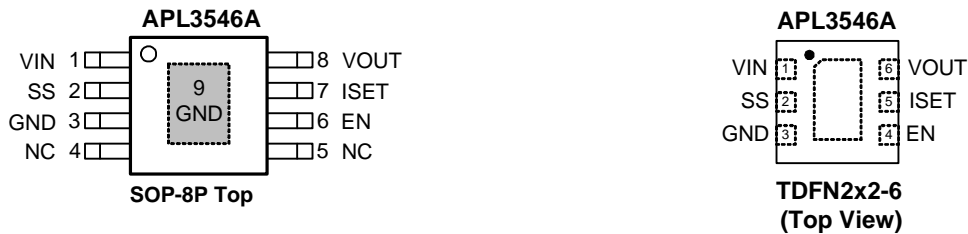

Ordering and Marking Information

<p>APL3546A □□-□□□</p> <p>├── Assembly Material</p> <p>├── Handling Code</p> <p>├── Temperature Range</p> <p>└── Package Code</p>	<p>Package Code</p> <p>KA : SOP-8P QB : TDFN2x2-6</p> <p>Operating Ambient Temperature Range</p> <p>I : -40 to 80°C</p> <p>Handling Code</p> <p>TR : Tape & Reel</p> <p>Assembly Material</p> <p>G : Halogen and Lead Free Device</p>				
<p>APL3546A KA: <table border="1" style="display: inline-table; vertical-align: middle;"><tr><td>APL3546A</td></tr><tr><td>XXXXX</td></tr></table> XXXXX - Date Code</p>	APL3546A	XXXXX	<p>APL3546A QB: <table border="1" style="display: inline-table; vertical-align: middle;"><tr><td>46A</td></tr><tr><td>X</td></tr></table> X - Date Code</p>	46A	X
APL3546A					
XXXXX					
46A					
X					

Note : ANPEC lead-free products contain molding compounds/die attach materials and 100% matte tin plate termination finish; which are fully compliant with RoHS. ANPEC lead-free products meet or exceed the lead-free requirements of IPC/JEDEC J-STD-020D for MSL classification at lead-free peak reflow temperature. ANPEC defines "Green" to mean lead-free (RoHS compliant) and halogen free (Br or Cl does not exceed 900ppm by weight in homogeneous material and total of Br and Cl does not exceed 1500ppm by weight).

Absolute Maximum Ratings (Note 1)

Symbol	Parameter	Rating	Unit
V_{IN}	VIN to GND Voltage	-0.3 ~ 26	V
V_{OUT}	VOU to GND Voltage	-0.3 ~ 26	V
V_{EN}	EN to GND Voltage	-0.3 ~ 7	V
V_{ISET}	ISET to GND Voltage	-0.3 ~ 7	V
V_{SS}	SS to GND Voltage	-0.3 ~ 7	V
I_{OUT}	IOU output current	Setting by R_{ISET}	A
T_J	Maximum Junction Temperature	-40 ~ 150	°C
T_{STG}	Storage Temperature	-65 ~ 150	°C
T_{SDR}	Maximum Lead Soldering Temperature (10 Seconds)	260	°C

Note1: Stresses beyond those listed under "absolute maximum ratings" may cause permanent damage to the device. These are stress ratings only and functional operation of the device at these or any other conditions beyond those indicated under "recommended operating conditions" is not implied. Exposure to absolute maximum rating conditions for extended periods may affect device reliability.

Thermal Characteristics (Note 2)

Symbol	Parameter	Typical Value	Unit
θ_{JA}	Junction-to-Ambient Resistance in Free Air	SOP-8P 75 TDFN2x2-6 130	$^{\circ}\text{C}/\text{W}$

Note 2: θ_{JA} is measured with the component mounted on a high effective thermal conductivity test board in free air.

Recommended Operating Conditions (Note 3)

Symbol	Parameter	Range	Unit
V_{IN}	VIN Input Voltage	4.5 ~ 24	V
C_{SS}	SS Pin Soft-Start Capacitor	VIN Input Voltage=4.5V ~ 7V	3.3n ~ 10n
		VIN Input Voltage=7V ~ 24V	1n ~ 10n
T_A	Ambient Temperature	-40 ~ 85	$^{\circ}\text{C}$
T_J	Junction Temperature	-40 ~ 125	$^{\circ}\text{C}$
I_{OUT}	IOUT continuous current.	2.5	A
I_{OUT}	IOUT output current	See Output Current vs. VIN Input Voltage curve	A

Note 3: Refer to the typical application circuit

Electrical Characteristics

Unless otherwise specified, these specifications apply over $V_{IN}=12\text{V}$, $V_{EN}=5\text{V}$. Typical values are at $T_A=25^{\circ}\text{C}$.

Symbol	Parameter	Test Conditions	APL3546A			Unit
			Min.	Typ.	Max.	
SUPPLY CURRENT						
	VIN Supply Current	No load, $V_{EN}=0\text{V}$	-	30	50	μA
		No load, $V_{EN}=5\text{V}$	-	250	400	μA
	Leakage Current	$V_{OUT}=\text{GND}$, $V_{EN}=0\text{V}$	-	-	1	μA
POWER SWITCH						
$R_{DS(ON)}$	Power Switch On Resistance	$I_{OUT}=2\text{A}$, $T_A=25^{\circ}\text{C}$, $V_{IN}=12\text{V}$	-	78	90	m Ω
		$I_{OUT}=2\text{A}$, $V_{IN}=12\text{V}$	-	78	100	m Ω
UNDER-VOLTAGE LOCKOUT						
	VIN UVLO Threshold Voltage		3.3	-	3.9	V
	VIN UVLO Hysteresis		-	0.2	-	V
CURRENT LIMIT AND SHORT CIRCUIT PROTECTIONS						
V_{ISET}	Current Limit Voltage	$V_{IN}=4.5\text{V}$ to 24V	-	0.6	-	V
I_{LIM}	Current Limit Threshold	$R_{ISET}=82\text{k}\Omega$	-	6.2	-	A
SOFT-START CONTROL PIN						
I_{SS}	SS Current	$V_{IN}=12\text{V}$,	1	2	3	μA
t_{SS}	Soft-Start Time	$V_{IN}=12\text{V}$, No load, $C_{OUT}=1\mu\text{F}$, $C_{SS}=1\text{nF}$	-	0.5	-	ms
		$V_{IN}=12\text{V}$, No load, $C_{OUT}=1\mu\text{F}$, $C_{SS}=\text{open}$	1	2	3	ms
	Soft-Star Discharge Resistance	$V_{EN}=0\text{V}$	-	300	-	Ω

Electrical Characteristics(Cont.)

Unless otherwise specified, these specifications apply over $V_{IN}=12V$, $V_{EN}=5V$. Typical values are at $T_A=25^{\circ}C$.

Symbol	Parameter	Test Conditions	APL3546A			Unit
			Min.	Typ.	Max.	
EN INPUT PIN						
V_{IH}	Input Logic High	$V_{IN}=4.5V$ to 24V	2	-	-	V
V_{IL}	Input Logic Low	$V_{IN}=4.5V$ to 24V	-	-	0.6	V
	Input Current		-	-	1	μA
	VOUT Discharge Resistance	$V_{EN}=0V$	-	950	-	Ω
$t_{D(ON)}$	Turn on Delay Time		-	300	-	μs
$t_{D(OFF)}$	Turn off Delay Time		-	3	-	μs
OVERT-TEMPERATURE PROTECTION (OTP)						
T_{OTP}	Over-Temperature Threshold	T_J rising	-	150	-	$^{\circ}C$

Pin Description

FUNCTION			
NO.		NAME	
SOP-8P	TDFN2x2-6		
1	1	VIN	Power Supply Input. Connect this pin to external DC supply.
2	2	SS	Soft Start Control Pin. Connect a capacitor to GND to control the soft start rate. If the SS pin is left floating the soft start time is 2ms when $V_{IN}=12V$.
3,9	3	GND	GND.
4	-	NC	No connection.
5	-	NC	No connection.
6	4	EN	Enable Input. Pull this pin to high to enable the device and pull this pin to low to disable device. The EN pin cannot be left floating.
7	5	ISET	Connect a resistor to GND to adjust OCP level.
8	6	VOUT	Output Voltage Pin. The output voltage follows the input voltage. When EN is low the output voltage is discharged by an internal resistor.

Typical Operating Characteristics

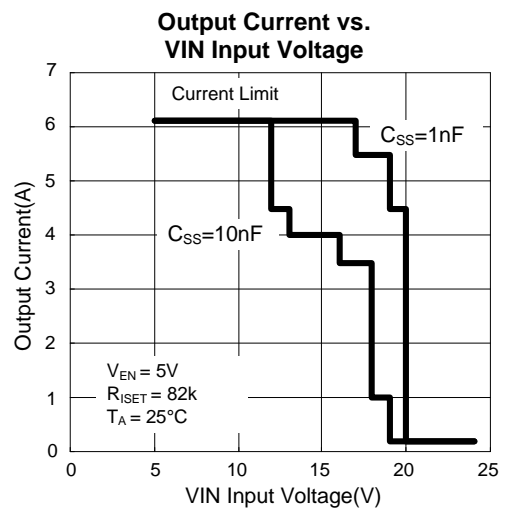
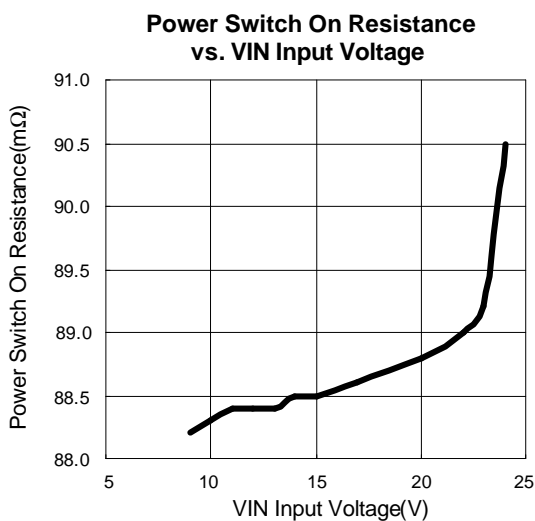
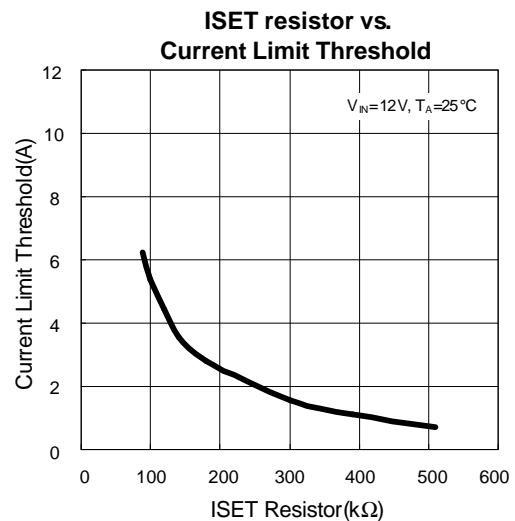
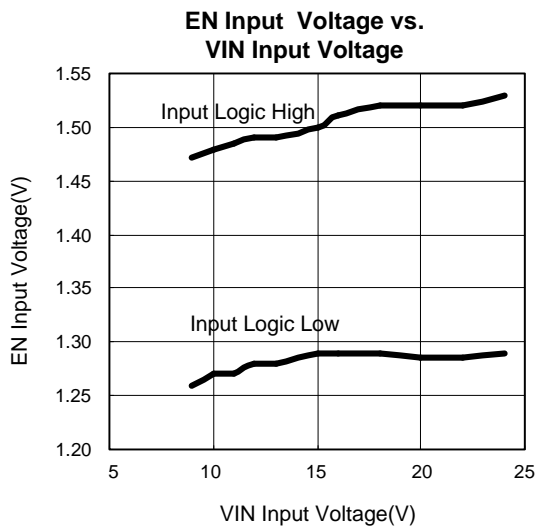
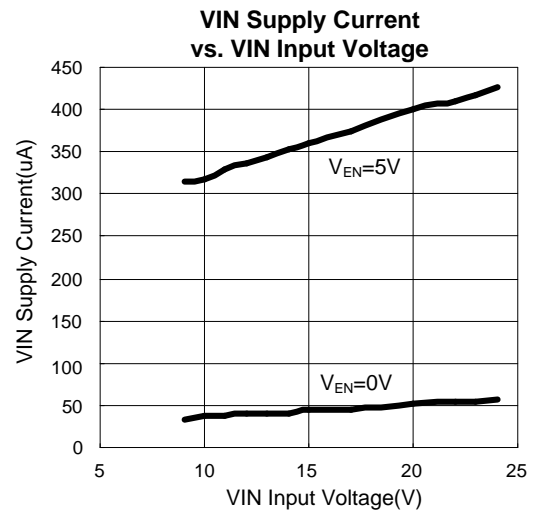
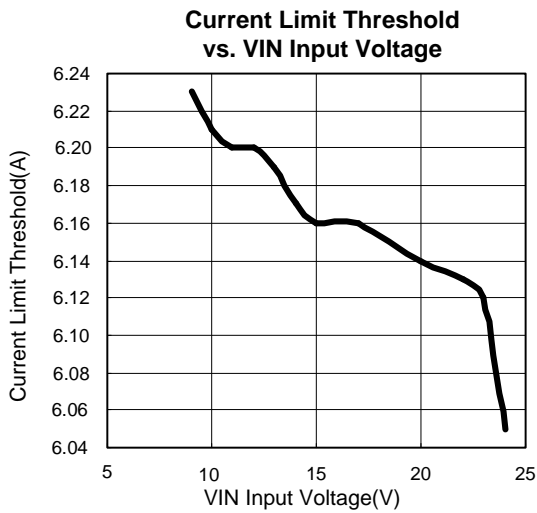

Operating Waveforms

Power On

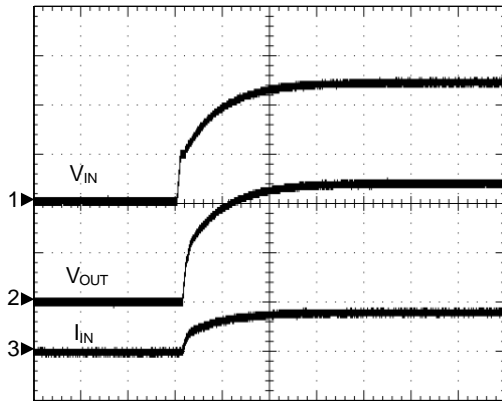

$V_{IN}=12V$, $C_{IN}=1\mu F$, $C_{OUT}=10\mu F$, $R_{OUT}=30\Omega$
 CH1: V_{IN} (5V/Div)
 CH2: V_{OUT} (5V/Div)
 CH3: I_{IN} (0.5A/Div)
 Time: 4ms/Div

Power Off

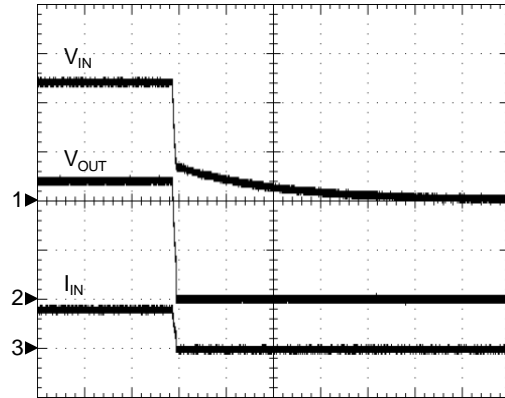

$V_{IN}=12V$, $C_{IN}=1\mu F$, $C_{OUT}=10\mu F$, $R_{OUT}=30\Omega$
 CH1: V_{IN} (5V/Div)
 CH2: V_{OUT} (5V/Div)
 CH3: I_{IN} (0.5A/Div)
 Time: 400ms/Div

Turn On Response

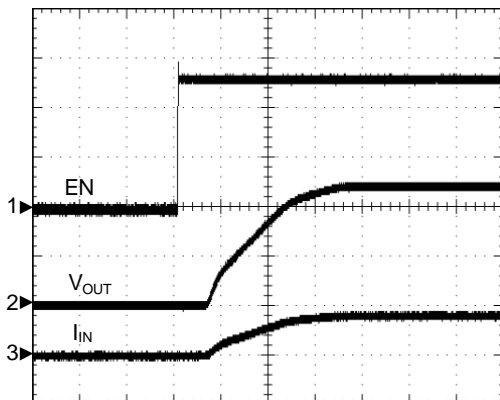

$V_{IN}=12V$, $C_{IN}=1\mu F$, $C_{OUT}=10\mu F$, $R_{OUT}=30\Omega$
 CH1: EN (2V/Div)
 CH2: V_{OUT} (5V/Div)
 CH3: I_{IN} (0.5A/Div)

Turn Off Response

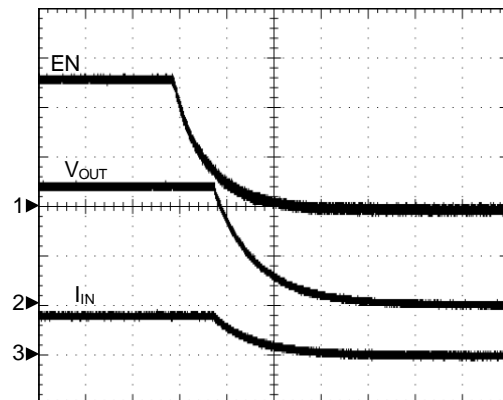

$V_{IN}=12V$, $C_{IN}=1\mu F$, $C_{OUT}=10\mu F$, $R_{OUT}=30\Omega$
 CH1: EN (2V/Div)
 CH2: V_{OUT} (5V/Div)
 CH3: I_{IN} (0.5A/Div)
 Time: 400us/Div

Operating Waveforms

Soft Start Ramp Up Control

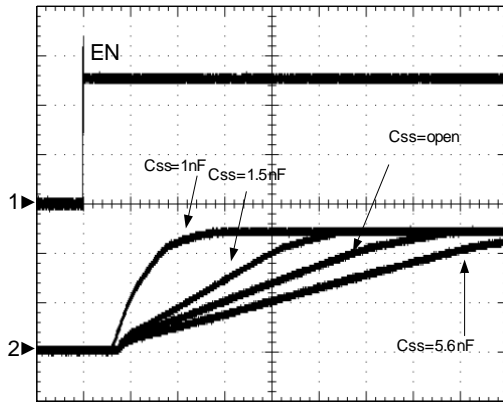

$V_{IN}=12V$, $C_{IN}=1\mu F$, $C_{OUT}=10\mu F$, $R_{OUT}=30\Omega$
 CH1: EN (2V/Div)
 CH2: V_{OUT} (5V/Div)
 Time: 400us/Div

Short Circuit Response

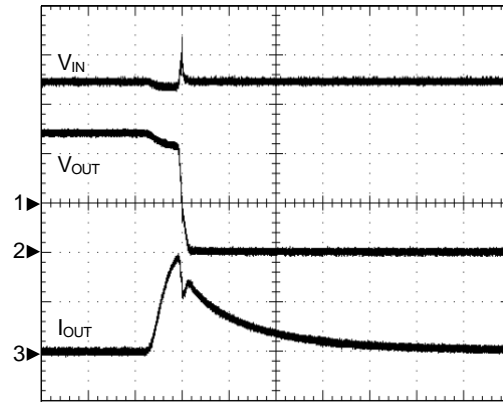

$V_{IN}=12V$, $C_{IN}=1\mu F$, $C_{OUT}=10\mu F$, $R_{ISET}=82k\Omega$
 CH1: V_{IN} (5V/Div)
 CH2: V_{OUT} (5V/Div)
 CH3: I_{OUT} (5A/Div)
 Time: 10us/Div

Block Diagram

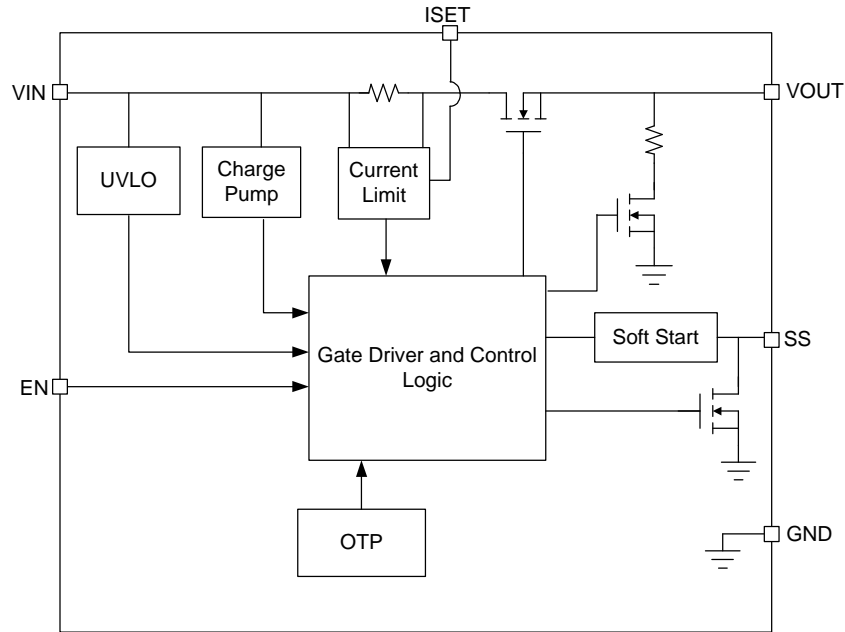

Typical Application Circuit

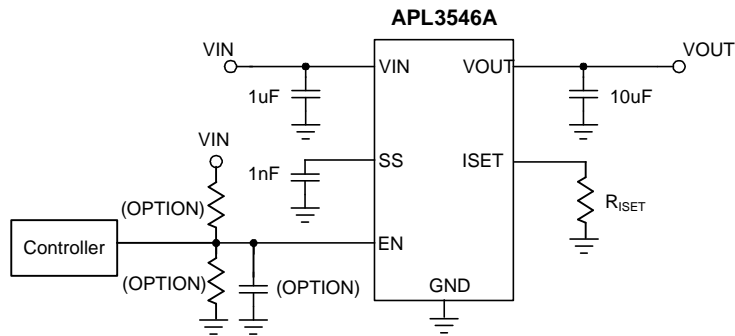

Function Description

Under-voltage Lockout (UVLO)

The APL3546A power switch is built-in an under-voltage lockout circuit to keep the output shut off until internal circuitry is operating properly. The UVLO circuit has hysteresis and a de-glitch feature so that it will typically ignore undershoot transients on the input. When input voltage exceeds the UVLO threshold, the output voltage starts a soft-start to reduce the inrush current.

Power Switch

The power switch is an N-channel MOSFET with a low RDS(ON). The internal power MOSFET does not have the body diode. When IC is off, the MOSFET prevents a current flowing from the VOUT back to VIN and VIN to VOUT.

Current Limit Protection

The APL3546A power switch provides the current limit protection function. When current limit occur, IC latch off. For reliable operation, the device should not be operated in current limit for extended period time.

Soft-Start

The APL3546A provides an adjustable soft-start circuitry to control rise rate of the output voltage and limit the current surge during start-up. The soft-start ramp-up rate is controlled by a capacitor from SS pin to ground. the soft start time can be calculated by this following equation:

$$t_{ss} = 0.1 (C_{SS} \times V_{IN}) / I_{SS}$$

where,

t_{ss} is soft start time of VOUT rising from 0 to 100%, of which unit is second.

C_{SS} is the value of the capacitor connected from SS pin to GND, of which unit is micro-Farad.

V_{IN} is the amplitude of input voltage applied to this device, of which unit is volt.

I_{SS} is the SS pin charge current, typical value is 2 μ A.

If the C_{SS} is not connected or tied to V_{IN} , the soft start time is 2ms when $V_{IN}=12V$.

Enable/Disable

Pull the EN below 0.6V to disable the device and pull EN above 2V to enable the device. When the IC is disabled the supply current is reduced to less than 35 μ A. The enable input is compatible with both TTL and CMOS logic levels. The EN pin cannot be left floating.

Over-temperature Protection

When the junction temperature exceeds 150 $^{\circ}$ C, the internal thermal sense circuit turns off the power FET and allows the device to cool down. When over temperature protection occur, IC latch off. Thermal protection is designed to protect the IC in the event of over temperature conditions. For normal operation, the junction temperature cannot exceed $T_J=+125^{\circ}$ C.

Application Information

Power Sequencing

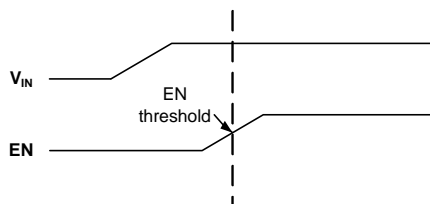

At start-up, it is necessary to ensure that the V_{IN} and EN are sequenced correctly.

Input Capacitor

A $1\mu\text{F}$ ceramic bypass capacitor from V_{IN} to GND, located near the APL3546A, is strongly recommended to suppress the ringing during short-circuit fault event. Without the bypass capacitor, the output short may cause sufficient ringing on the input (from supply lead inductance) to damage internal control circuitry.

Output Capacitor

A low-ESR $10\mu\text{F}$ MLCC, aluminum electrolytic or tantalum between VO_{UT} and GND is strongly recommended to reduce the voltage droop during hot-attachment of downstream peripheral. Higher-value output capacitor is better when the output load is heavy. Additionally, bypassing the output with a $0.1\mu\text{F}$ ceramic capacitor improves the immunity of the device to short-circuit transients.

Soft-Start Capacitor

The APL3546A has a built-in adjustable soft-start control for user to set an optimum soft-start time for the application. The soft-start time can be calculated by the equation, described in the paragraph of Soft-Start in Functional Description section. The soft-start time will become internally controlled as if there is no C_{SS} , $t_{SS}=2\text{ms}$ when $V_{IN}=12\text{V}$. Please note that there minimum value of soft start capacitor in different V_{IN} input voltage. Please make sure the C_{SS} is in the recommended value.

Layout Consideration

The PCB layout should be carefully performed to maximize thermal dissipation and to minimize voltage drop, droop and EMI. The following guidelines must be considered:

1. Please place the input capacitors near the V_{IN} pin as close as possible.
2. Output decoupling capacitors for load must be placed near the load as close as possible for decoupling high frequency ripples.
3. Locate APL3546A and output capacitors near the load to reduce parasitic resistance and inductance for excellent load transient performance.
4. The negative pins of the input and output capacitors and the GND pin must be connected to the ground plane of the load.
5. Keep V_{IN} and V_{OUT} traces as wide and short as possible.

Current Limit Setting

The current limit can be set by connecting resistor from the current limit adjustable pin ISET to ground. The required value of resistor R_{ISET} for current limit is calculated as follows:

$$R_{ISET} = 510000 / I_{LM}$$

Package Information

SOP-8P

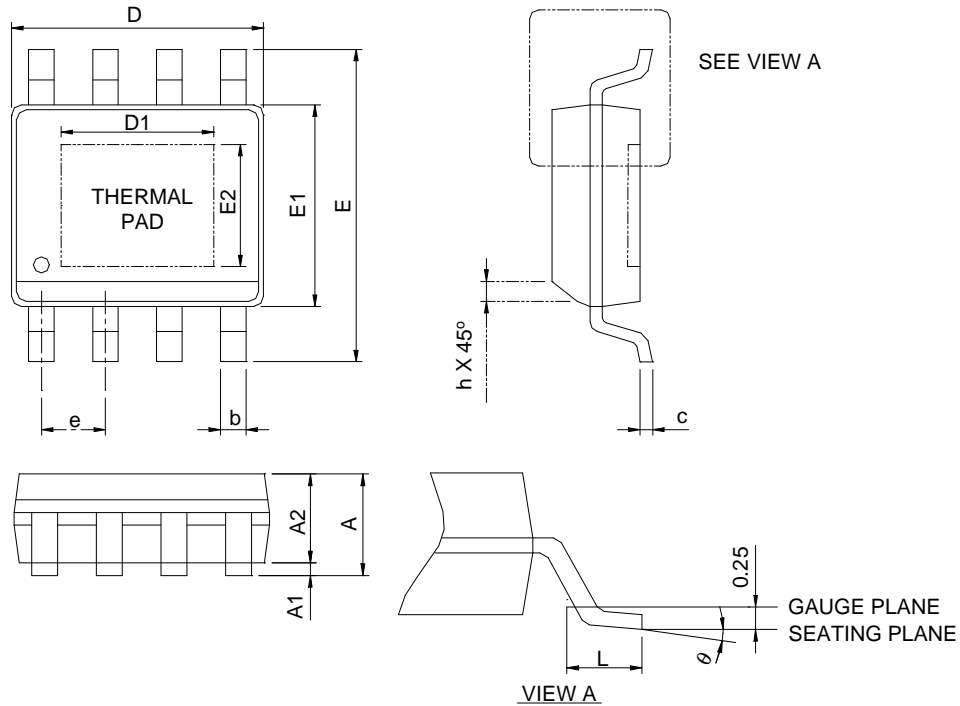

SYMBOL	SOP-8P			
	MILLIMETERS		INCHES	
	MIN.	MAX.	MIN.	MAX.
A		1.60		0.063
A1	0.00	0.15	0.000	0.006
A2	1.25		0.049	
b	0.31	0.51	0.012	0.020
c	0.17	0.25	0.007	0.010
D	4.80	5.00	0.189	0.197
D1	2.50	3.50	0.098	0.138
E	5.80	6.20	0.228	0.244
E1	3.80	4.00	0.150	0.157
E2	2.00	3.00	0.079	0.118
e	1.27 BSC		0.050 BSC	
h	0.25	0.50	0.010	0.020
L	0.40	1.27	0.016	0.050
θ	0°C	8°C	0°C	8°C

- Note : 1. Followed from JEDEC MS-012 BA.
 2. Dimension "D" does not include mold flash, protrusions or gate burrs. Mold flash, protrusion or gate burrs shall not exceed 6 mil per side .
 3. Dimension "E" does not include inter-lead flash or protrusions. Inter-lead flash and protrusions shall not exceed 10 mil per side.

Package Information

TDFN2x2-6

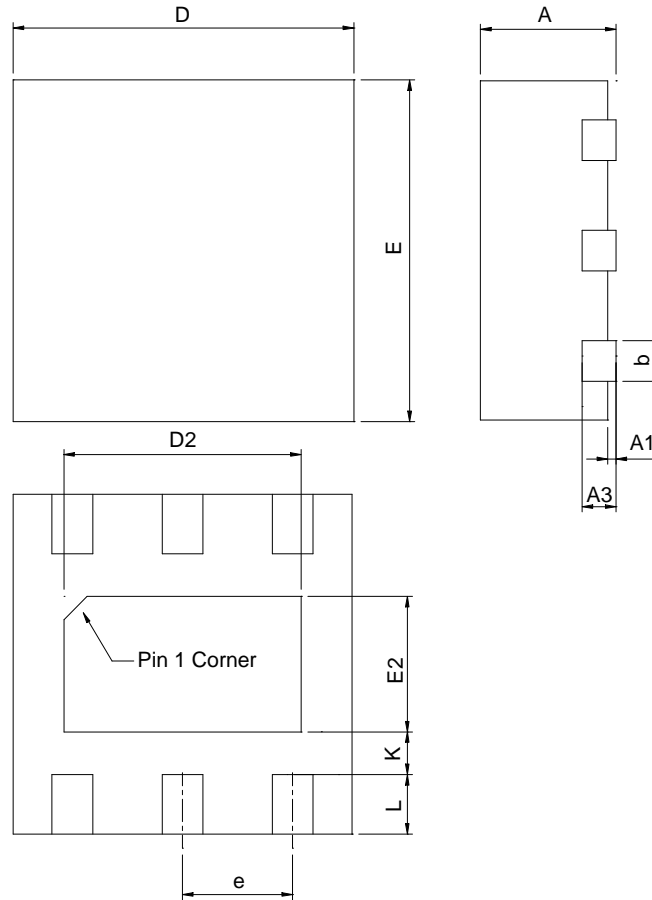

SYMBOL	TDFN2x2-6			
	MILLIMETERS		INCHES	
	MIN.	MAX.	MIN.	MAX.
A	0.70	0.80	0.028	0.031
A1	0.00	0.05	0.000	0.002
A3	0.20 REF		0.008 REF	
b	0.18	0.30	0.007	0.012
D	1.90	2.10	0.075	0.083
D2	1.00	1.60	0.039	0.063
E	1.90	2.10	0.075	0.083
E2	0.60	1.00	0.024	0.039
e	0.65 BSC		0.026 BSC	
L	0.30	0.45	0.012	0.018
K	0.20		0.008	

Note : 1. Followed from JEDEC MO-229 WCCG.

Carrier Tape & Reel Dimensions

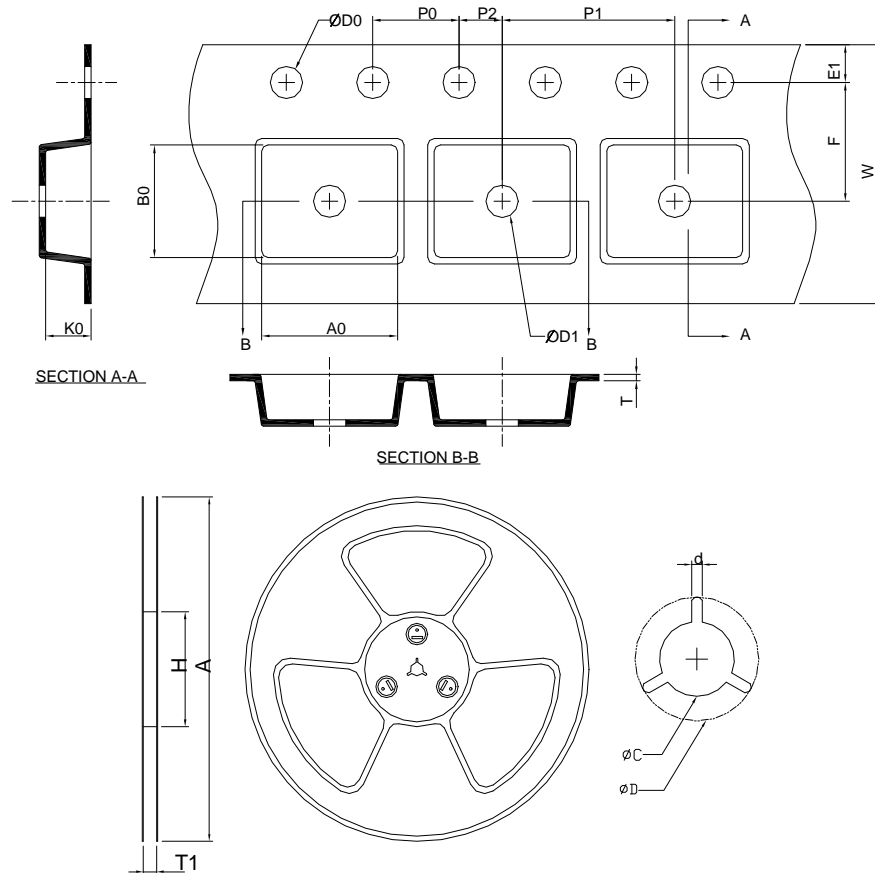

Application	A	H	T1	C	d	D	W	E1	F
SOP-8P	330.0 ±0.00	50 MIN.	12.4+2.00 -0.00	13.0+0.50 -0.20	1.5 MIN.	20.2 MIN.	12.0 ±0.30	1.75 ±0.10	5.5 ±0.05
	P0	P1	P2	D0	D1	T	A0	B0	K0
	4.0 ±0.10	8.0 ±0.10	2.0 ±0.05	1.5+0.10 -0.00	1.5 MIN.	0.6+0.00 -0.40	6.55 ±0.20	5.25 ±0.20	2.10 ±0.20
Application	A	H	T1	C	d	D	W	E1	F
TDFN2x2-6	178.0 ±0.00	50 MIN.	8.4+2.00 -0.00	13.0+0.50 -0.20	1.5 MIN.	20.2 MIN.	8.0 ±0.20	1.75 ±0.10	3.5 ±0.05
	P0	P1	P2	D0	D1	T	A0	B0	K0
	4.0 ±0.10	4.0 ±0.10	2.0 ±0.05	1.5+0.10 -0.00	1.5 MIN.	0.6+0.00 -0.40	2.35 ±0.20	2.35 ±0.20	1.00 ±0.20

(mm)

Devices Per Unit

Package Type	Unit	Quantity
SOP-8P	Tape & Reel	2500
TDFN2x2-6	Tape & Reel	3000

Taping Direction Information

SOP-8P

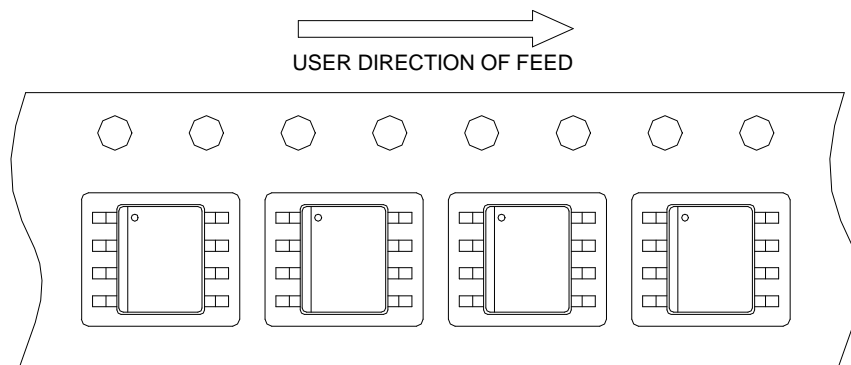

TDFN2x2-6

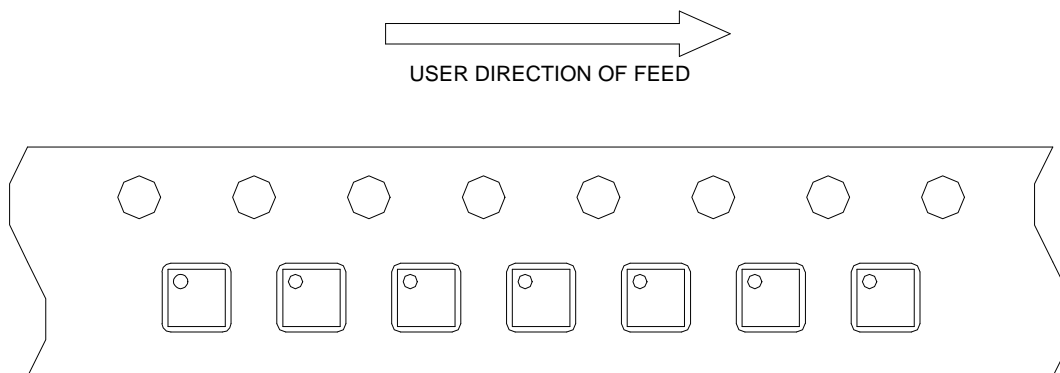

Classification Profile

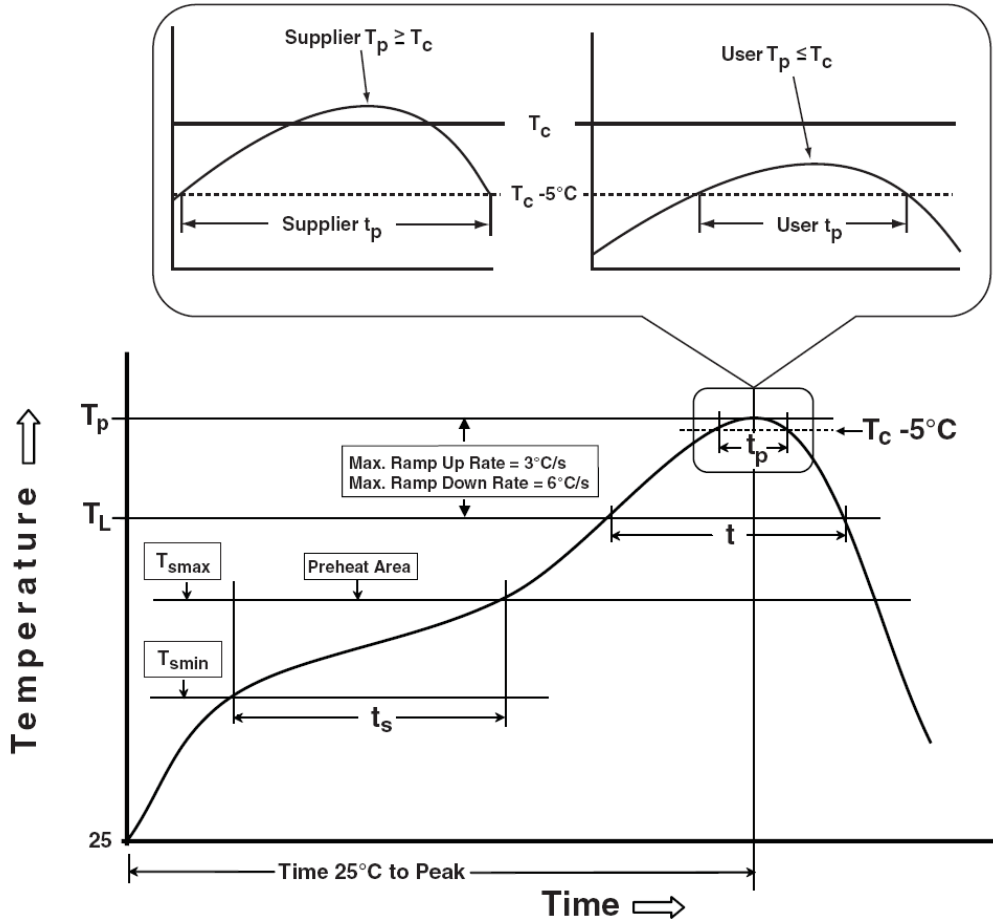

Classification Reflow Profiles

Profile Feature	Sn-Pb Eutectic Assembly	Pb-Free Assembly
Preheat & Soak Temperature min (T_{smin}) Temperature max (T_{smax}) Time (T_{smin} to T_{smax}) (t_s)	100 °C 150 °C 60-120 seconds	150 °C 200 °C 60-120 seconds
Average ramp-up rate (T_{smax} to T_p)	3 °C/second max.	3°C/second max.
Liquidous temperature (T_L) Time at liquidous (t_L)	183 °C 60-150 seconds	217 °C 60-150 seconds
Peak package body Temperature (T_p)*	See Classification Temp in table 1	See Classification Temp in table 2
Time (t_p)** within 5°C of the specified classification temperature (T_c)	20** seconds	30** seconds
Average ramp-down rate (T_p to T_{smax})	6 °C/second max.	6 °C/second max.
Time 25°C to peak temperature	6 minutes max.	8 minutes max.
* Tolerance for peak profile Temperature (T_p) is defined as a supplier minimum and a user maximum. ** Tolerance for time at peak profile temperature (t_p) is defined as a supplier minimum and a user maximum.		

Table 1. SnPb Eutectic Process – Classification Temperatures (T_c)

Package Thickness	Volume mm ³ <350	Volume mm ³ ≥350
<2.5 mm	235 °C	220 °C
≥2.5 mm	220 °C	220 °C

Table 2. Pb-free Process – Classification Temperatures (T_c)

Package Thickness	Volume mm ³ <350	Volume mm ³ 350-2000	Volume mm ³ >2000
<1.6 mm	260 °C	260 °C	260 °C
1.6 mm – 2.5 mm	260 °C	250 °C	245 °C
≥2.5 mm	250 °C	245 °C	245 °C

Reliability Test Program

Test item	Method	Description
SOLDERABILITY	JESD-22, B102	5 Sec, 245°C
HOLT	JESD-22, A108	1000 Hrs, Bias @ $T_j=125^\circ\text{C}$
PCT	JESD-22, A102	168 Hrs, 100%RH, 2atm, 121°C
TCT	JESD-22, A104	500 Cycles, -65°C~150°C
HBM	MIL-STD-883-3015.7	VHBM 2KV
MM	JESD-22, A115	VMM 200V
Latch-Up	JESD 78	10ms, 1 _{tr} 100mA

Customer Service

Anpec Electronics Corp.

Head Office :

No.6, Dusing 1st Road, SBIP,
Hsin-Chu, Taiwan, R.O.C.
Tel : 886-3-5642000
Fax : 886-3-5642050

Taipei Branch :

2F, No. 11, Lane 218, Sec 2 Jhongsing Rd.,
Sindian City, Taipei County 23146, Taiwan
Tel : 886-2-2910-3838
Fax : 886-2-2917-3838