

**FEATURES**

- Dual channel
- 16-bit resolution: **AD5547**
- 14-bit resolution: **AD5557**
- 2- or 4-quadrant, 6.8 MHz BW multiplying DAC
- ±1 LSB DNL
- ±1 LSB INL
- Operating supply voltage: 2.7 V to 5.5 V
- Low noise: 12 nV/ $\sqrt{\text{Hz}}$
- Low power:  $I_{DD} = 10 \mu\text{A}$  max
- 0.5  $\mu\text{s}$  settling time
- Built-in  $R_{FB}$  facilitates current-to-voltage conversion
- Built-in 4-quadrant resistors allow 0 V to -10 V, 0 V to +10 V,  
or ±10 V outputs
- 2 mA full-scale current ± 20%, with  $V_{REF} = 10\text{ V}$
- Extended automotive operating temperature range  
-40°C to +125°C
- Selectable zero-scale/midscale power-on presets
- Compact 38-lead TSSOP package

**APPLICATIONS**

- Automatic test equipment
- Instrumentation
- Digitally controlled calibration
- Digital waveform generation

**FUNCTIONAL BLOCK DIAGRAM**

Figure 1.

**GENERAL DESCRIPTION**

The **AD5547/AD5557** are dual precision, 16-/14-bit, multiplying, low power, current-output, parallel input, digital-to-analog converters (DACs). They are designed to operate from single +5 V supply with ±10 V multiplying references for 4-quadrant outputs with 6.8 MHz bandwidth.

The built-in, 4-quadrant resistors facilitate resistance matching and temperature tracking, which minimize the number of components needed for multiquadrant applications. In addition, the feedback resistor ( $R_{FB}$ ) simplifies the I-to-V conversion with an external buffer.

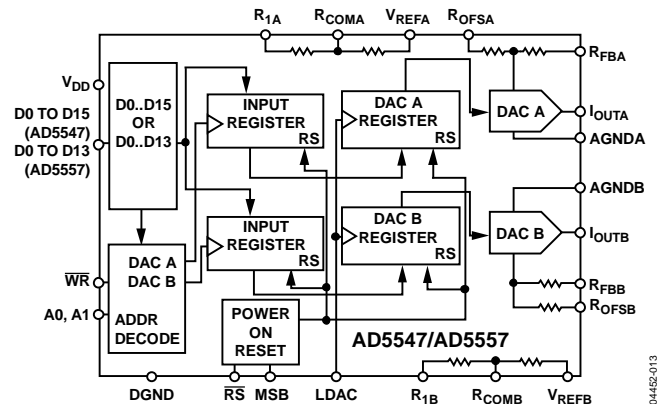
The **AD5547/AD5557** are available in a compact, 38-lead TSSOP package and operate at the extended automotive temperature range of -40°C to +125°C.

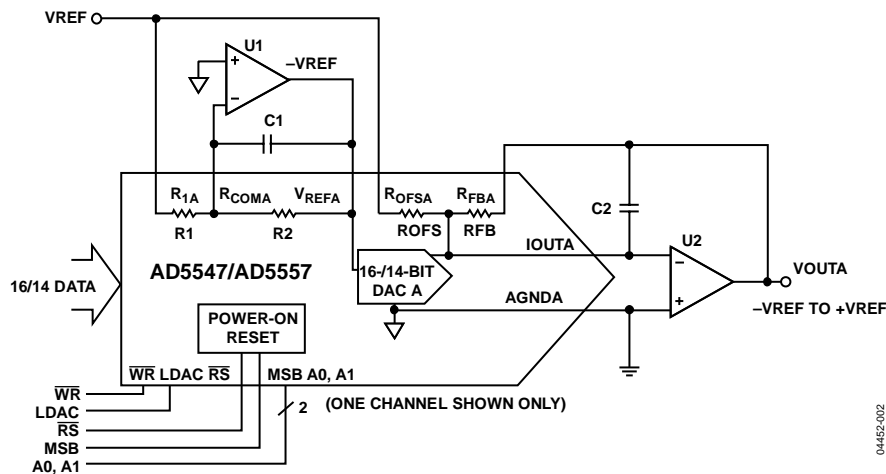

Figure 2. 16-/14-Bit 4-Quadrant Multiplying DAC with Minimum of External Components (Only One Channel Is Shown)

Rev. D

[Document Feedback](#)

Information furnished by Analog Devices is believed to be accurate and reliable. However, no responsibility is assumed by Analog Devices for its use, nor for any infringements of patents or other rights of third parties that may result from its use. Specifications subject to change without notice. No license is granted by implication or otherwise under any patent or patent rights of Analog Devices. Trademarks and registered trademarks are the property of their respective owners.

One Technology Way, P.O. Box 9106, Norwood, MA 02062-9106, U.S.A.  
Tel: 781.329.4700 ©2004–2012 Analog Devices, Inc. All rights reserved.  
[Technical Support](#) [www.analog.com](http://www.analog.com)

## TABLE OF CONTENTS

Features .....	1	DAC Section.....	12
Applications.....	1	Digital Section .....	13
Functional Block Diagram .....	1	PCB Layout, Power Supply Bypassing, and Ground Connections .....	13
General Description .....	1	Applications Information .....	14
Revision History .....	2	Unipolar Mode .....	14
Specifications.....	3	Bipolar Mode .....	16
Electrical Characteristics .....	3	Reference Selection .....	18
Absolute Maximum Ratings.....	5	Amplifier Selection .....	18
ESD Caution.....	5	Outline Dimensions .....	20
Pin Configurations and Function Descriptions .....	6	Ordering Guide .....	20
Typical Performance Characteristics .....	10		
Circuit Operation .....	12		

## REVISION HISTORY

### 11/12—Rev. C to Rev. D

Changes to Figure 22..... 15

### 11/11—Rev. B to Rev. C

Added Figure 14; Renumbered Sequentially ..... 11

### 4/10—Rev. A to Rev. B

Changes to Features Section and General Description Section . 1  
 Changes to Table 1..... 3  
 Deleted Figure 17 and Figure 18; Renumbered Sequentially ... 10  
 Changes to Figure 15 and Figure 16..... 11  
 Changes to Figure 20..... 14  
 Added Reference Selection Section, Amplifier Selection Section,  
 Table 10, and Table 11; Renumbered Sequentially..... 18

Added Table 12..... 19

### 9/09—Rev. 0 to Rev. A

Changes to Features Section .....1  
 Changes to Static Performance, Relative Accuracy,  
 Grade: AD5547C Parameter, Table 1.....3  
 Changes to Ordering Guide..... 19

### 1/04—Revision 0: Initial Version

## SPECIFICATIONS

## ELECTRICAL CHARACTERISTICS

$V_{DD} = 2.7 \text{ V to } 5.5 \text{ V}$ ,  $I_{OUT} = \text{virtual GND}$ ,  $\text{GND} = 0 \text{ V}$ ,  $V_{REF} = -10 \text{ V to } +10 \text{ V}$ ,  $T_A = -40^\circ\text{C to } +125^\circ\text{C}$ , unless otherwise noted.

Table 1.

Parameter	Symbol	Test Conditions/Comments	Min	Typ	Max	Unit
STATIC PERFORMANCE <sup>1</sup>						
Resolution	N	AD5547, 1 LSB = $V_{REF}/2^{16} = 153 \mu\text{V}$ at $V_{REF} = 10 \text{ V}$ AD5557, 1 LSB = $V_{REF}/2^{14} = 610 \mu\text{V}$ at $V_{REF} = 10 \text{ V}$		16		Bits
Relative Accuracy	INL	Grade: AD5557C Grade: AD5547B Grade: AD5547C		14	$\pm 1$	Bits
Differential Nonlinearity	DNL	Monotonic			$\pm 2$	LSB
Output Leakage Current	$I_{OUT}$	Data = zero scale, $T_A = 25^\circ\text{C}$ Data = zero scale, $T_A = T_A \text{ maximum}$			$\pm 1$	LSB
Full-Scale Gain Error	$G_{FSE}$	Data = full scale		$\pm 1$	$\pm 4$	LSB
Bipolar Mode Gain Error	$G_E$	Data = full scale		$\pm 1$	$\pm 4$	nA
Bipolar Mode Zero-Scale Error	$G_{ZSE}$	Data = full scale		$\pm 1$	$\pm 3$	nA
Full-Scale Temperature Coefficient <sup>2</sup>	$TCV_{FS}$			1		ppm/ $^\circ\text{C}$
REFERENCE INPUT						
$V_{REF}$ Range	$V_{REF}$		-18		+18	V
REF Input Resistance	REF		4	5	6	k $\Omega$
R1 and R2 Resistance	R1 and R2		4	5	6	k $\Omega$
R1-to-R2 Mismatch	$\Delta(\text{R1 to R2})$			$\pm 0.5$	$\pm 1.5$	$\Omega$
Feedback and Offset Resistance	$R_{FB}$ , $R_{OFS}$		8	10	12	k $\Omega$
Input Capacitance <sup>2</sup>	$C_{REF}$			5		pF
ANALOG OUTPUT						
Output Current	$I_{OUT}$	Data = full scale		2		mA
Output Capacitance <sup>2</sup>	$C_{OUT}$	Code dependent		200		pF
LOGIC INPUT AND OUTPUT						
Logic Input Low Voltage	$V_{IL}$	$V_{DD} = 5 \text{ V}$ $V_{DD} = 3 \text{ V}$			0.8	V
Logic Input High Voltage	$V_{IH}$	$V_{DD} = 5 \text{ V}$ $V_{DD} = 3 \text{ V}$	2.4		0.4	V
Input Leakage Current	$I_{IL}$		2.1		10	$\mu\text{A}$
Input Capacitance <sup>2</sup>	$C_{IL}$				10	pF
INTERFACE TIMING <sup>2, 3</sup>						
Data to $\overline{\text{WR}}$ Setup Time	$t_{DS}$	See Figure 3 $V_{DD} = 5 \text{ V}$ $V_{DD} = 3 \text{ V}$		20		ns
Data to $\overline{\text{WR}}$ Hold Time	$t_{DH}$	$V_{DD} = 5 \text{ V}$ $V_{DD} = 3 \text{ V}$		35		ns
$\overline{\text{WR}}$ Pulse Width	$t_{\overline{\text{WR}}}$	$V_{DD} = 5 \text{ V}$ $V_{DD} = 3 \text{ V}$		0		ns
LDAC Pulse Width	$t_{LDAC}$	$V_{DD} = 5 \text{ V}$ $V_{DD} = 3 \text{ V}$		20		ns
$\overline{\text{RS}}$ Pulse Width	$t_{RS}$	$V_{DD} = 5 \text{ V}$ $V_{DD} = 3 \text{ V}$		35		ns
$\overline{\text{WR}}$ to LDAC Delay Time	$t_{LWD}$	$V_{DD} = 5 \text{ V}$ $V_{DD} = 3 \text{ V}$		20		ns
				35		ns
				0		ns
				0		ns

Parameter	Symbol	Test Conditions/Comments	Min	Typ	Max	Unit
<b>SUPPLY CHARACTERISTICS</b>						
Power Supply Range	$V_{DD\ RANGE}$		2.7		5.5	V
Positive Supply Current	$I_{DD}$	Logic inputs = 0 V			10	$\mu A$
Power Dissipation	$P_{DISS}$	Logic inputs = 0 V			0.055	mW
Power Supply Sensitivity	$P_{SS}$	$\Delta V_{DD} = \pm 5\%$			0.003	%/%
<b>AC CHARACTERISTICS<sup>4</sup></b>						
Output Voltage Settling Time	$t_s$	To $\pm 0.1\%$ of full scale, data cycles from zero scale to full scale to zero scale		0.5		$\mu s$
Reference Multiplying BW	BW	$V_{REF} = 100\ mV\ rms$ , data = full scale		6.8		MHz
DAC Glitch Impulse	Q	$V_{REF} = 0\ V$ , midscale - 1 to midscale		-3.5		nV-s
Multiplying Feedthrough Error	$V_{OUT}/V_{REF}$	$V_{REF} = 100\ mV\ rms$ , $f = 10\ kHz$		-78		dB
Digital Feedthrough	$Q_D$	$\overline{WR} = 1$ , LDAC toggles at 1 MHz		7		nV-s
Total Harmonic Distortion	THD	$V_{REF} = 5\ V\ p-p$ , data = full scale, $f = 1\ kHz$		-104		dB
Output Noise Density	$e_N$	$f = 1\ kHz$ , BW = 1 Hz		12		$nV/\sqrt{Hz}$
Analog Crosstalk	$C_{AT}$	Signal input at Channel A and measures the output at Channel B, $f = 1\ kHz$		-95		dB

<sup>1</sup> All static performance tests (except  $I_{OUT}$ ) are performed in a closed-loop system using an external precision OP97 I-to-V converter amplifier. The device  $R_{FB}$  terminal is tied to the amplifier output. The +IN pin of the OP97 is grounded, and the  $I_{OUT}$  of the DAC is tied to the OP97's -IN pin. Typical values represent average readings measured at 25°C.

<sup>2</sup> Guaranteed by design; not subject to production testing.

<sup>3</sup> All input control signals are specified with  $t_R = t_F = 2.5\ ns$  (10% to 90% of 3 V) and are timed from a voltage level of 1.5 V.

<sup>4</sup> All ac characteristic tests are performed in a closed-loop system using an AD8038 I-to-V converter amplifier except for THD where the AD8065 was used.

## Timing Diagram

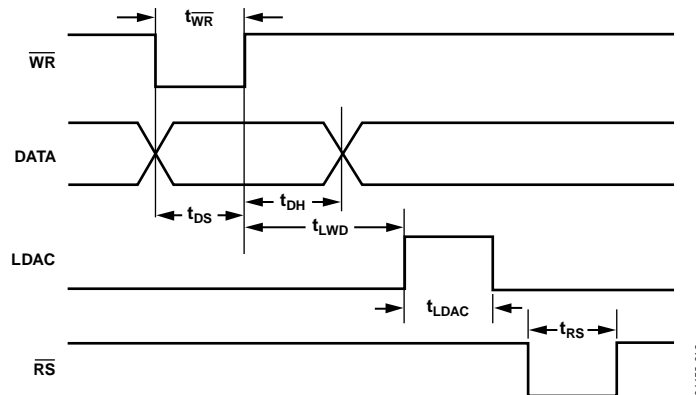

Figure 3. AD5547/AD5557 Timing Diagram

04462-018

## ABSOLUTE MAXIMUM RATINGS

Table 2.

Parameter	Rating
$V_{DD}$ to GND	-0.3 V to +8 V
$R_{FB}$ , $R_{OF5}$ , $R1$ , $R_{COM}$ , and VREF to GND	-18 V to +18 V
Logic Inputs to GND	-0.3 V to +8 V
$V(I_{OUT})$ to GND	-0.3 V to $V_{DD} + 0.3$ V
Input Current to Any Pin except Supplies	$\pm 50$ mA
Thermal Resistance ( $\theta_{JA}$ ) <sup>1</sup>	
Maximum Junction Temperature ( $T_{JMAX}$ )	150°C
Operating Temperature Range	-40°C to +125°C
Storage Temperature Range	-65°C to +150°C
Lead Temperature	
Vapor Phase, 60 sec	215°C
Infrared, 15 sec	220°C

<sup>1</sup> Package power dissipation =  $(T_{JMAX} - T_A)/\theta_{JA}$ .

Stresses above those listed under Absolute Maximum Ratings may cause permanent damage to the device. This is a stress rating only; functional operation of the device at these or any other conditions above those indicated in the operational section of this specification is not implied. Exposure to absolute maximum rating conditions for extended periods may affect device reliability.

### ESD CAUTION



**ESD (electrostatic discharge) sensitive device.** Charged devices and circuit boards can discharge without detection. Although this product features patented or proprietary protection circuitry, damage may occur on devices subjected to high energy ESD. Therefore, proper ESD precautions should be taken to avoid performance degradation or loss of functionality.

## PIN CONFIGURATIONS AND FUNCTION DESCRIPTIONS

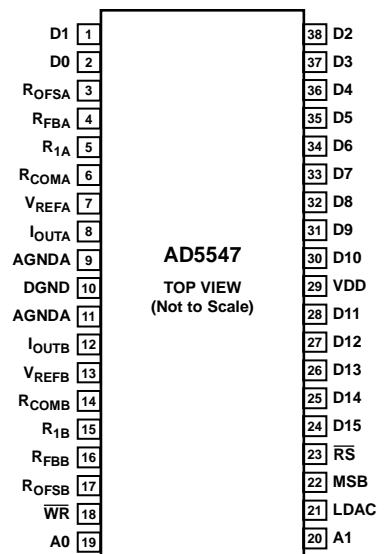

Figure 4. AD5547 Pin Configuration

Table 3. AD5547 Pin Function Descriptions

Pin No.	Mnemonic	Function
1, 2, 24 to 28, 30 to 38	D0 to D15	Digital Input Data Bits D0 to D15. Signal level must be $\leq V_{DD} + 0.3 V$ .
3	$R_{OFSA}$	Bipolar Offset Resistor A. Accepts up to $\pm 18 V$ . In 2-quadrant mode, $R_{OFSA}$ ties to $R_{FBA}$ . In 4-quadrant mode, $R_{OFSA}$ ties to $R_{1A}$ and the external reference.
4	$R_{FBA}$	Internal Matching Feedback Resistor A. Connects to the external op amp for I-to-V conversion.
5	$R_{1A}$	4-Quadrant Resistor. In 2-quadrant mode, $R_{1A}$ shorts to the $V_{REFA}$ pin. In 4-quadrant mode, $R_{1A}$ ties to $R_{OFSA}$ . Do not connect when operating in unipolar mode.
6	$R_{COMA}$	Center Tap Point of the Two 4-Quadrant Resistors, $R_{1A}$ and $R_{2A}$ . In 4-quadrant mode, $R_{COMA}$ ties to the inverting node of the reference amplifier. In 2-quadrant mode, $R_{COMA}$ shorts to the associated $V_{REFA}$ pin. Do not connect if operating in unipolar mode.
7	$V_{REFA}$	DAC A Reference Input in 2-Quadrant Mode, R2 Terminal in 4-Quadrant Mode. In 2-quadrant mode, $V_{REFA}$ is the reference input with constant input resistance vs. code. In 4-quadrant mode, $V_{REFA}$ is driven by the external reference amplifier.
8	$I_{OUTA}$	DAC A Current Output. Connects to the inverting terminal of external precision I-to-V op amp for voltage output.
9	AGNDA	DAC A Analog Ground.
10	DGND	Digital Ground.
11	AGNDB	DAC B Analog Ground.
12	$I_{OUTB}$	DAC B Current Output. Connects to inverting terminal of external precision I-to-V op amp for voltage output.
13	$V_{REFB}$	DAC B Reference Input Pin. Establishes DAC full-scale voltage. Constant input resistance vs. code. If configured with an external op amp for 4-quadrant multiplying, $V_{REFB}$ becomes $-V_{REF}$ .
14	$R_{COMB}$	Center Tap Point of the Two 4-Quadrant Resistors, $R_{1B}$ and $R_{2B}$ . In 4-quadrant mode, $R_{COMB}$ ties to the inverting node of the reference amplifier. In 2-quadrant mode, $R_{COMB}$ shorts to the $V_{REFB}$ pin. Do not connect if operating in unipolar mode.
15	$R_{1B}$	4-Quadrant Resistor. In 2-quadrant mode, $R_{1B}$ shorts to the $V_{REFB}$ pin. In 4-quadrant mode, $R_{1B}$ ties to $R_{OFSB}$ . Do not connect if operating in unipolar mode.
16	$R_{FBB}$	Internal Matching Feedback Resistor B. Connects to external op amp for I-to-V conversion.
17	$R_{OFSB}$	Bipolar Offset Resistor B. Accepts up to $\pm 18 V$ . In 2-quadrant mode, $R_{OFSB}$ ties to $R_{FBB}$ . In 4-quadrant mode, $R_{OFSB}$ ties to $R_{1B}$ and an external reference.
18	$\overline{WR}$	Write Control Digital Input In, Active Low. $\overline{WR}$ transfers shift register data to the DAC register on the rising edge. Signal level must be $\leq V_{DD} + 0.3 V$ .

Pin No.	Mnemonic	Function
19	A0	Address Pin 0. Signal level must be $\leq V_{DD} + 0.3\text{ V}$ .
20	A1	Address Pin 1. Signal level must be $\leq V_{DD} + 0.3\text{ V}$ .
21	LDAC	Digital Input Load DAC Control. Signal level must be $\leq V_{DD} + 0.3\text{ V}$ .
22	MSB	Power-On Reset State. MSB = 0 corresponds to zero-scale reset; MSB = 1 corresponds to midscale reset. The signal level must be $\leq V_{DD} + 0.3\text{ V}$ .
23	$\overline{\text{RS}}$	Active low resets both input and DAC registers. Resets to zero-scale if MSB = 0 and resets to midscale if MSB = 1. Signal level must be $\leq V_{DD} + 0.3\text{ V}$ .
29	VDD	Positive Power Supply Input. The specified range of operation is 2.7 V to 5.5 V.

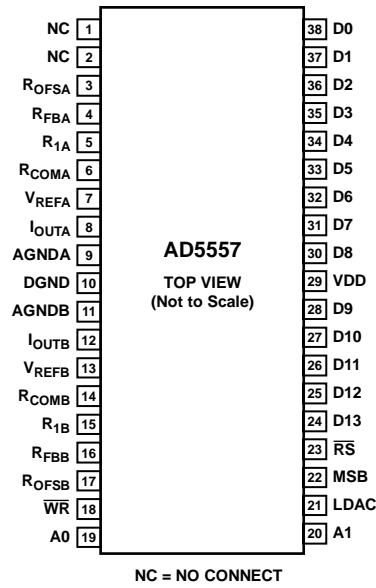

Figure 5. AD5557 Pin Configuration

Table 4. AD5557 Pin Function Descriptions



Pin No.	Mnemonic	Function
1, 2	NC	No Connection. Do not connect anything other than the dummy pads to these pins.
3	R <sub>OFSA</sub>	Bipolar Offset Resistor A. Accepts up to $\pm 18$ V. In 2-quadrant mode, R <sub>OFSA</sub> ties to R <sub>FBA</sub> . In 4-quadrant mode, R <sub>OFSA</sub> ties to R <sub>1A</sub> and the external reference.
4	R <sub>FBA</sub>	Internal Matching Feedback Resistor A. Connects to the external op amp for I-to-V conversion.
5	R <sub>1A</sub>	4-Quadrant Resistor. In 2-quadrant mode, R <sub>1A</sub> shorts to the V <sub>REFA</sub> pin. In 4-quadrant mode, R <sub>1A</sub> ties to R <sub>OFSA</sub> . Do not connect when operating in unipolar mode.
6	R <sub>COMA</sub>	Center Tap Point of the Two 4-Quadrant Resistors, R <sub>1A</sub> and R <sub>2A</sub> . In 4-quadrant mode, R <sub>COMA</sub> ties to the inverting node of the reference amplifier. In 2-quadrant mode, R <sub>COMA</sub> shorts to the V <sub>REFA</sub> pin. Do not connect if operating in unipolar mode.
7	V <sub>REFA</sub>	DAC A Reference Input in 2-Quadrant Mode, R2 Terminal in 4-Quadrant Mode. In 2-quadrant mode, V <sub>REFA</sub> is the reference input with constant input resistance vs. code. In 4-quadrant mode, V <sub>REFA</sub> is driven by the external reference amplifier.
8	I <sub>OUTA</sub>	DAC A Current Output. Connects to the inverting terminal of external precision I-to-V op amp for voltage output.
9	AGNDA	DAC A Analog Ground.
10	DGND	Digital Ground.
11	AGNDB	DAC B Analog Ground.
12	I <sub>OUTB</sub>	DAC B Current Output. Connects to inverting terminal of external precision I-to-V op amp for voltage output.
13	V <sub>REFB</sub>	DAC B Reference Input Pin. Establishes DAC full-scale voltage. Constant input resistance vs. code. If configured with an external op amp for 4-quadrant multiplying, V <sub>REFB</sub> becomes $-V_{REF}$ .
14	R <sub>COMB</sub>	Center Tap Point of the Two 4-Quadrant Resistors, R <sub>1B</sub> and R <sub>2B</sub> . In 4-quadrant mode, R <sub>COMB</sub> ties to the inverting node of the reference amplifier. In 2-quadrant mode, R <sub>COMB</sub> shorts to the V <sub>REFB</sub> pin. Do not connect if operating in unipolar mode.
15	R <sub>1B</sub>	4-Quadrant Resistor. In 2-quadrant mode, R <sub>1B</sub> shorts to the V <sub>REFB</sub> pin. In 4-quadrant mode, R <sub>1B</sub> ties to R <sub>OFSB</sub> . Do not connect if operating in unipolar mode.
16	R <sub>FBB</sub>	Internal Matching Feedback Resistor B. Connects to external op amp for I-to-V conversion.
17	R <sub>OFSB</sub>	Bipolar Offset Resistor B. Accepts up to $\pm 18$ V. In 2-quadrant mode, R <sub>OFSB</sub> ties to R <sub>FBB</sub> . In 4-quadrant mode, R <sub>OFSB</sub> ties to R <sub>1B</sub> and an external reference.
18	WR	Write Control Digital Input In, Active Low. Transfers shift register data to the DAC register on the rising edge. Signal level must be $\leq V_{DD} + 0.3$ V.
19	A0	Address Pin 0. Signal level must be $\leq V_{DD} + 0.3$ V.
20	A1	Address Pin 1. Signal level must be $\leq V_{DD} + 0.3$ V.
21	LDAC	Digital Input Load DAC Control. Signal level must be $\leq V_{DD} + 0.3$ V.
22	MSB	Power-On Reset State. MSB = 0 corresponds to zero-scale reset; MSB = 1 corresponds to midscale reset. The signal level must be $\leq V_{DD} + 0.3$ V.

Pin No.	Mnemonic	Function
23	$\overline{RS}$	Active low resets both input and DAC registers. Resets to zero-scale if MSB = 0 and resets to midscale if MSB = 1. Signal level must be $\leq V_{DD} + 0.3\text{ V}$ .
24 to 28, 30 to 38	D13 to D0	Digital Input Data Bits D13 to D0. Signal level must be $\leq V_{DD} + 0.3\text{ V}$ .
29	VDD	Positive Power Supply Input. The specified range of operation is 2.7 V to 5.5 V.

Table 5. Address Decoder Pins

A1	A0	Output Update
0	0	DAC A
0	1	None
1	0	DAC A and DAC B
1	1	DAC B

Table 6. Control Inputs

$\overline{RS}$	$\overline{WR}$	LDAC	Register Operation
0	X	X	Reset the output to 0 with MSB = 0; reset the output to midscale with MSB = 1.
1	0	0	Load the input register with data bits.
1	1	1	Load the DAC register with the contents of the input register.
1	0	1	The input and DAC registers are transparent.
1			When LDAC and $\overline{WR}$ are tied together and programmed as a pulse, the data bits are loaded into the input register on the falling edge of the pulse and are then loaded into the DAC register on the rising edge of the pulse.
1	1	0	No register operation.

TYPICAL PERFORMANCE CHARACTERISTICS

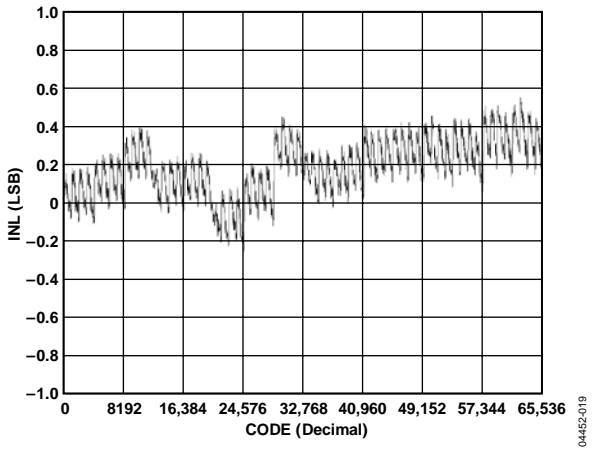

Figure 6. AD5547 Integral Nonlinearity Error

04462-019

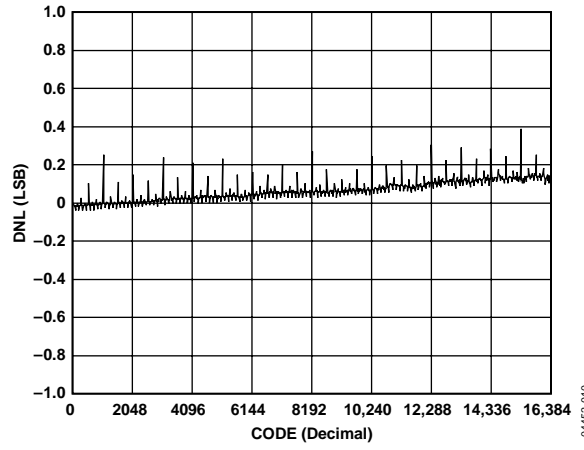

Figure 9. AD5557 Differential Nonlinearity Error

04462-010

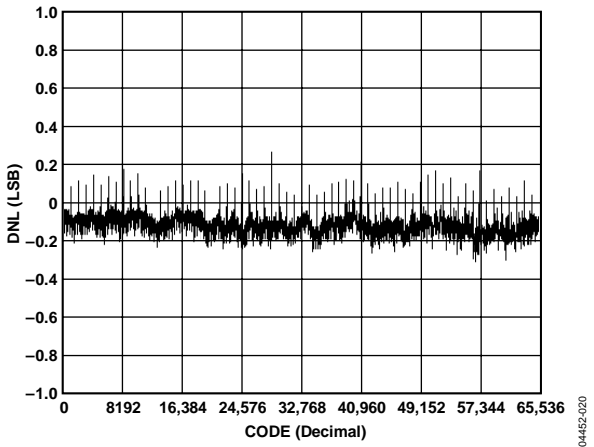

Figure 7. AD5547 Differential Nonlinearity Error

04462-020

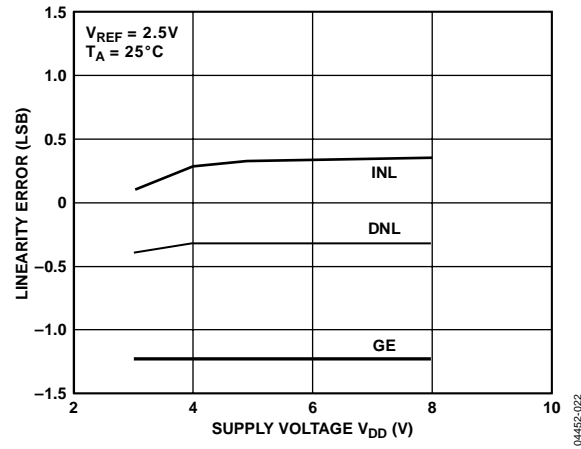

Figure 10. Linearity Error vs. Supply Voltage,  $V_{DD}$

04462-022

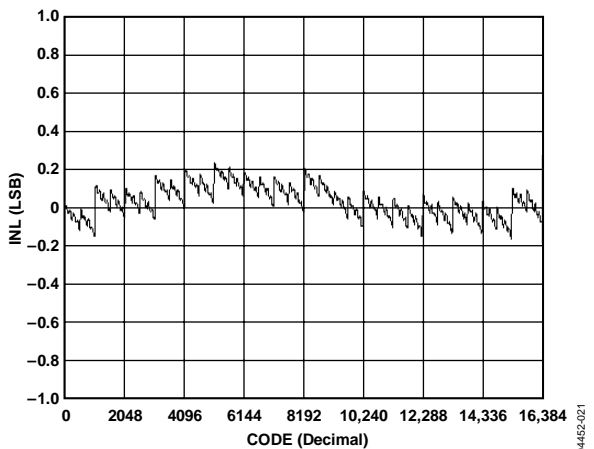

Figure 8. AD5557 Integral Nonlinearity Error

04462-021

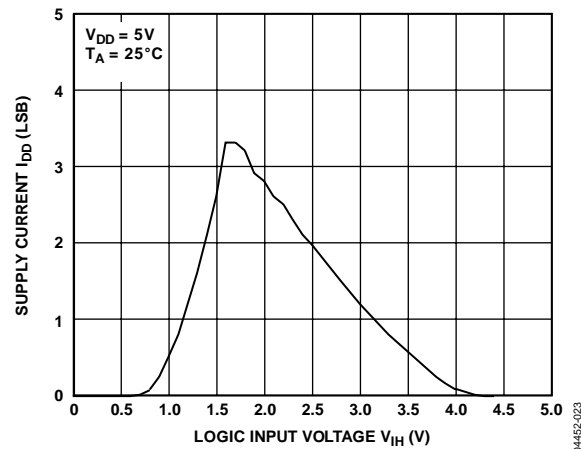

Figure 11. Supply Current vs. Logic Input Voltage

04462-023

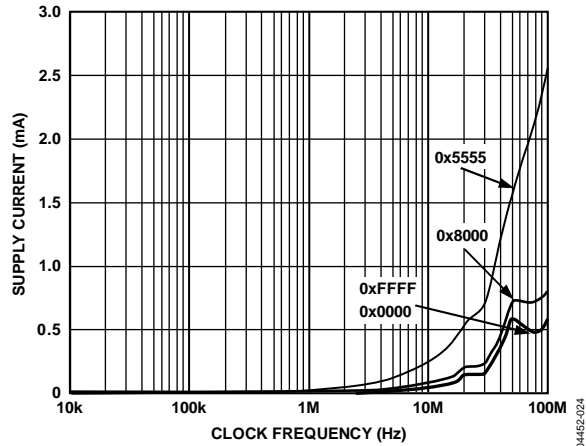

Figure 12. AD5547 Supply Current vs. Clock Frequency

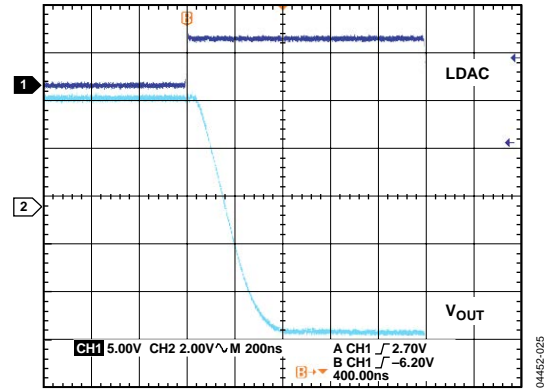

Figure 15. Settling Time from Full Scale to Zero Scale

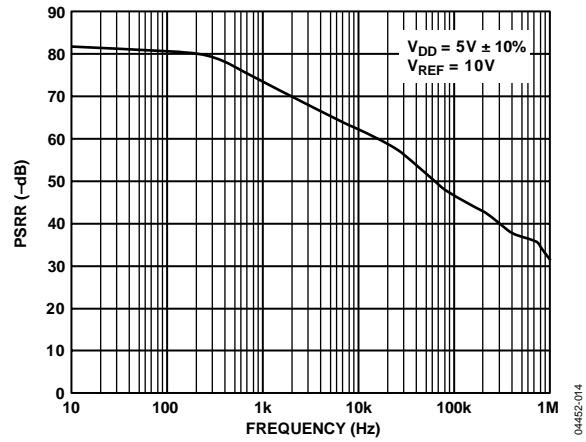

Figure 13. Power Supply Rejection Ratio (PSRR) vs. Frequency

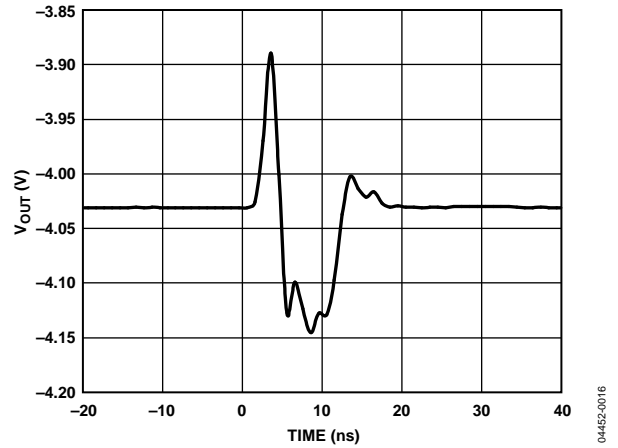

Figure 16. AD5547 Midscale Transition and Digital Feedthrough

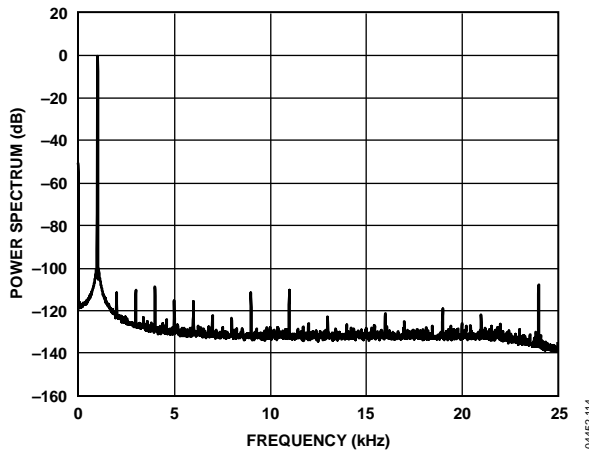

Figure 14. AD5547/AD5557 Analog Total Harmonic Distortion (THD)

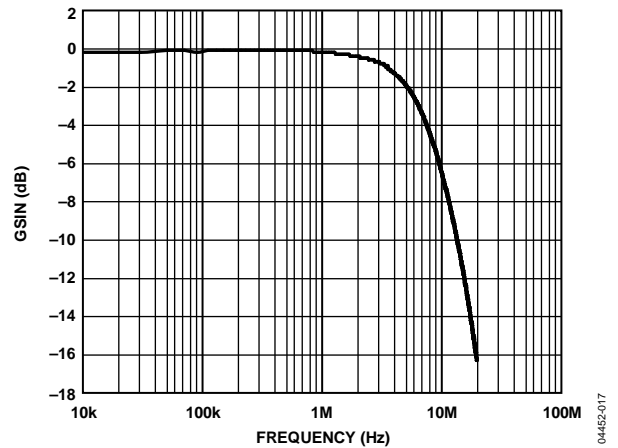

Figure 17. AD5547 Unipolar Reference Multiplying Bandwidth

## CIRCUIT OPERATION

### DAC SECTION

The AD5547/AD5557 are 16-/14-bit, multiplying, current-output, parallel input DACs. The devices operate from a single 2.7 V to 5.5 V supply and provide both unipolar (0 V to  $-V_{REF}$  or 0 V to  $+V_{REF}$ ) and bipolar ( $\pm V_{REF}$ ) output ranges from  $-18$  V to  $+18$  V references. In addition to the precision conversion  $R_{FB}$  commonly found in current output DACs, there are three additional precision resistors for 4-quadrant bipolar applications.

The AD5547/AD5557 consist of two groups of precision R-2R ladders, which make up the 12/10 LSBs, respectively. Furthermore, the 4 MSBs are decoded into 15 segments of resistor value  $2R$ . Figure 18 shows the architecture of the 16-bit AD5547. Each of the 16 segments and the R-2R ladder carries an equally weighted current of one-sixteenth of full scale. The feedback resistor  $R_{FB}$  and 4-quadrant resistor  $R_{OFS}$  have values of  $10\text{ k}\Omega$ . Each 4-quadrant resistor,  $R1$  and  $R2$ , equals  $5\text{ k}\Omega$ . In 4-quadrant operation,  $R1$ ,  $R2$ , and an external op amp work together to invert the reference voltage and apply it to the  $V_{REF}$  input. With  $R_{OFS}$  and  $R_{FB}$  connected as shown in Figure 2, the output can swing from  $-V_{REF}$  to  $+V_{REF}$ .

The reference voltage inputs exhibit a constant input resistance of  $5\text{ k}\Omega \pm 20\%$ . The impedance of  $I_{OUT}$ , the DAC output, is code dependent. External amplifier choice should take into account the variation of the AD5547/AD5557 output impedance. The feedback resistance in parallel with the DAC ladder resistance dominates output voltage noise. To maintain good analog performance, it is recommended that the power supply is bypassed with a  $0.01\text{ }\mu\text{F}$  to  $0.1\text{ }\mu\text{F}$  ceramic or chip capacitor in parallel with a  $1\text{ }\mu\text{F}$  tantalum capacitor. Also, to minimize gain error, PCB metal traces between  $V_{REF}$  and  $R_{FB}$  should match.

Every code change of the DAC corresponds to a step function; gain peaking at each output step may occur if the op amp has limited GBP and excessive parasitic capacitance present at the inverting node of the op amp. A compensation capacitor, therefore, may be needed between the I-to-V op amp inverting and output nodes to smooth the step transition. Such a compensation capacitor should be found empirically, but a  $20\text{ pF}$  capacitor is generally adequate for the compensation.

The  $V_{DD}$  power is used primarily by the internal logic to drive the DAC switches. Note that the output precision degrades if the operating voltage falls below the specified voltage. Users should also avoid using switching regulators because device power supply rejection degrades at higher frequencies.

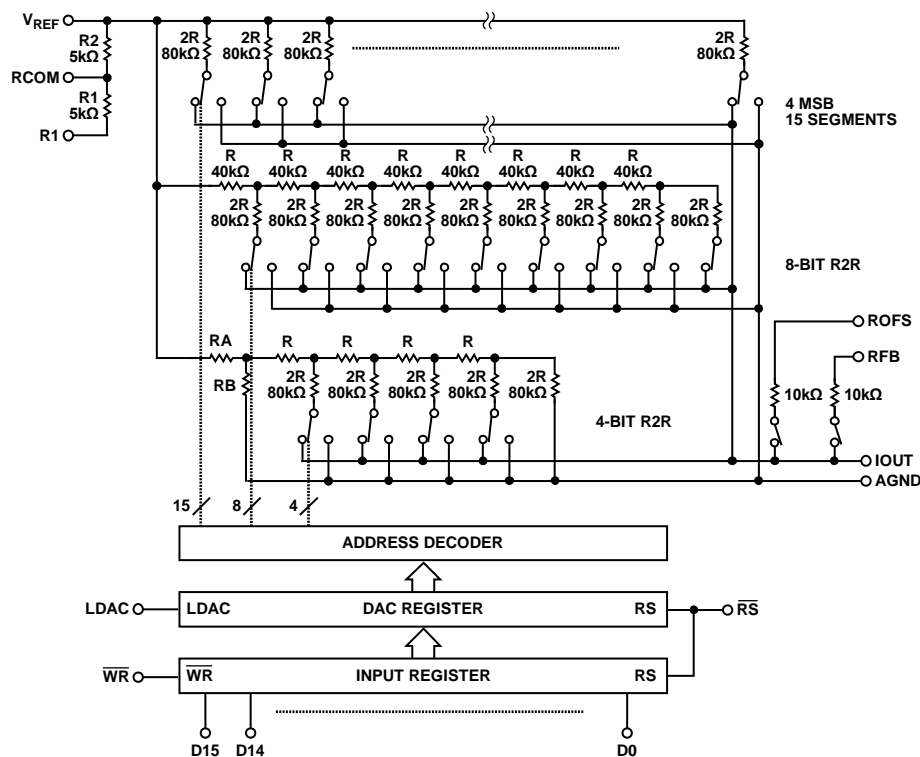

Figure 18. 16-Bit AD5547 Equivalent R-2R DAC Circuit with Digital Section, One Channel Shown

04452-011

## DIGITAL SECTION

The AD5547/AD5557 have 16-/14-bit parallel inputs. The devices are double buffered with 16-/14-bit registers. The double buffered feature allows the simultaneous update of several AD5547s/AD5557s. For the AD5547, the input register is loaded directly from a 16-bit controller bus when  $\overline{WR}$  is brought low. The DAC register is updated with data from the input register when LDAC is brought high. Updating the DAC register updates the DAC output with the new data (see Figure 18). To make both registers transparent, tie  $\overline{WR}$  low and LDAC high. The asynchronous  $\overline{RS}$  pin resets the part to zero scale if MSB = 0 and to midscale if MSB = 1.

### ESD Protection Circuits

All logic input pins contain back-biased ESD protection Zeners connected to ground (DGND) and  $V_{DD}$ , as shown in Figure 19. As a result, the voltage level of the logic input should not be greater than the supply voltage.

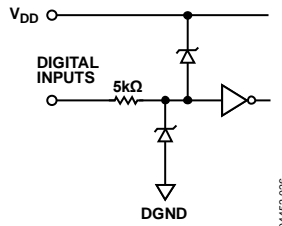

Figure 19. Equivalent ESD Protection Circuits

### Amplifier Selection

In addition to offset voltage, the bias current is important in op amp selection for precision current output DACs. A 30 nA input bias current in the op amp contributes to 1 LSB in the full-scale error of the AD5547. The OP1177 and AD8628 op amps are good candidates for the I-to-V conversion.

### Reference Selection

The initial accuracy and rated output of the voltage reference determine the full-span adjustment. The initial accuracy of the reference is usually a secondary concern because it can be trimmed. Figure 25 shows an example of a trimming circuit. The zero-scale error can also be minimized by standard op amp nulling techniques.

The voltage reference temperature coefficient (TC) and long-term drift are primary considerations. For example, a 5 V reference with a TC of 5 ppm/°C means the output changes by 25  $\mu\text{V}/^\circ\text{C}$ . As a result, a reference operating at 55°C contributes an additional 750  $\mu\text{V}$  full-scale error.

Similarly, the same 5 V reference with a  $\pm 50$  ppm long-term drift means the output may change by  $\pm 250$   $\mu\text{V}$  over time. Therefore, it is practical to calibrate a system periodically to maintain its optimum precision.

## PCB LAYOUT, POWER SUPPLY BYPASSING, AND GROUND CONNECTIONS

It is a good practice to employ a compact, minimum lead length, PCB layout design. The leads to the input should be as short as possible to minimize IR drop and stray inductance.

The PCB metal traces between  $V_{REF}$  and  $R_{FB}$  should also be matched to minimize gain error.

It is also essential to bypass the power supply with quality capacitors for optimum stability. Supply leads to the device should be bypassed with 0.01  $\mu\text{F}$  to 0.1  $\mu\text{F}$  disc or chip ceramic capacitors. Low ESR 1  $\mu\text{F}$  to 10  $\mu\text{F}$  tantalum or electrolytic capacitors should also be applied at the supply in parallel with the ceramic capacitor to minimize transient disturbance and filter out low frequency ripple.

To minimize the digital ground bounce, the AD5547/AD5557 DGND terminal should be joined with the AGND terminal at a single point. Figure 20 illustrates the basic supply bypassing configuration and AGND/DGND connection for the AD5547/AD5557.

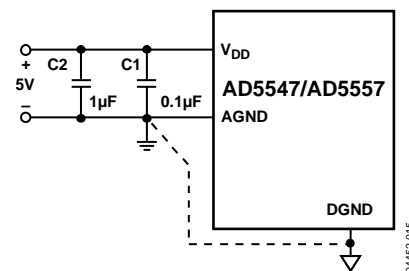

Figure 20. Power Supply Bypassing

# APPLICATIONS INFORMATION

## UNIPOLAR MODE

### 2-Quadrant Multiplying Mode, $V_{OUT} = 0\text{ V to }-V_{REF}$

The AD5547/AD5557 DAC architecture uses a current-steering R-2R ladder design that requires an external reference and op amp to convert the unipolar mode of the output voltage to

$$V_{OUT} = -V_{REF} \times D/65,536 \text{ (AD5547)} \quad (1)$$

$$V_{OUT} = -V_{REF} \times D/16,384 \text{ (AD5557)} \quad (2)$$

where  $D$  is the decimal equivalent of the input code.

In this case, the output voltage polarity is opposite the  $V_{REF}$  polarity (see Figure 21). Table 7 shows the negative output vs. code for the AD5547.

Table 7. AD5547 Unipolar Mode Negative Output vs. Code

D in Binary	$V_{OUT}$ (V)
1111 1111 1111 1111	$-V_{REF}$ (65,535/65,536)
1000 0000 0000 0000	$-V_{REF}/2$
0000 0000 0000 0001	$-V_{REF}$ (1/65,536)
0000 0000 0000 0000	0

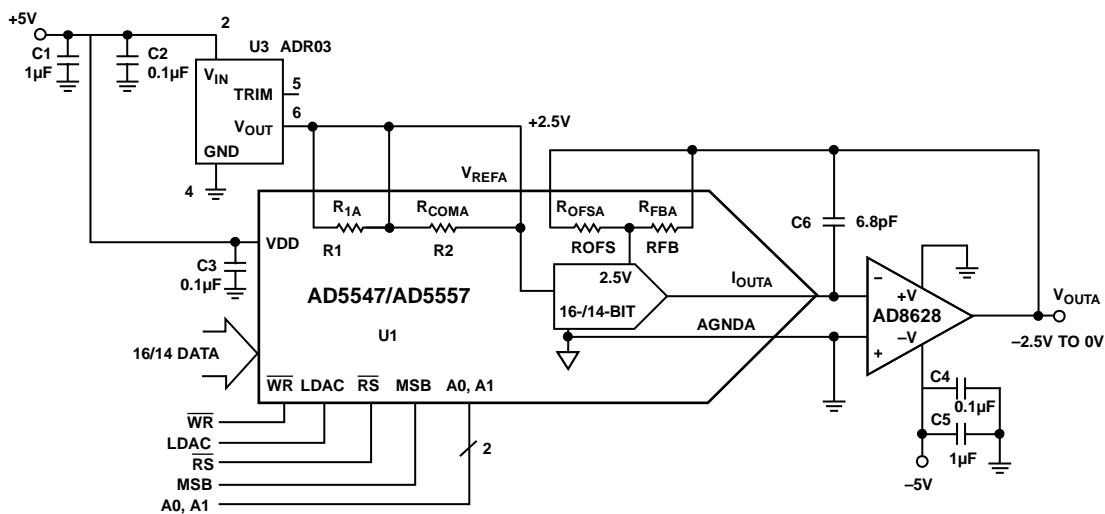

Figure 21. Unipolar 2-Quadrant Multiplying Mode,  $V_{OUT} = 0\text{ to }-V_{REF}$

04452-007

**2-Quadrant Multiplying Mode,  $V_{OUT} = 0\text{ V to }+V_{REF}$**

The AD5547/AD5557 are designed to operate with either positive or negative reference voltages. As a result, a positive output can be achieved with an additional op amp, (see Figure 22); the output becomes

$$V_{OUT} = +V_{REF} \times D/65,536 \text{ (AD5547)} \quad (3)$$

$$V_{OUT} = +V_{REF} \times D/16,384 \text{ (AD5557)} \quad (4)$$

Table 8 shows the positive output vs. code for the AD5547.

**Table 8. AD5547 Unipolar Mode Positive Output vs. Code**

D in Binary	$V_{OUT}$ (V)
1111 1111 1111 1111	$+V_{REF}(65,535/65,536)$
1000 0000 0000 0000	$+V_{REF}/2$
0000 0000 0000 0001	$+V_{REF}(1/65,536)$
0000 0000 0000 0000	0

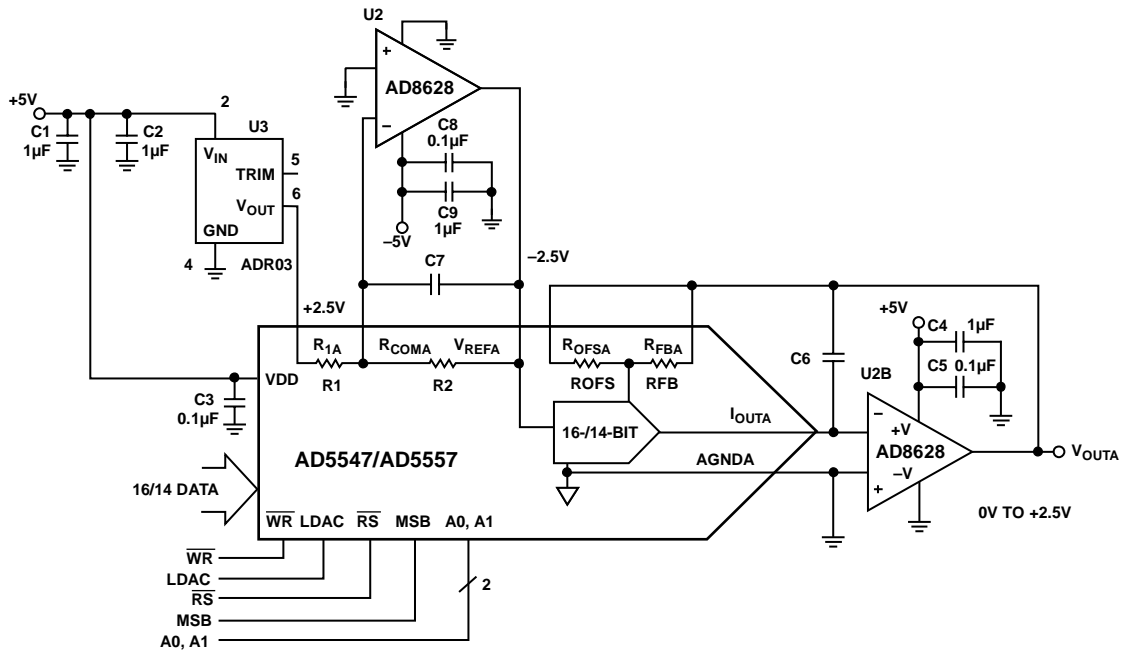

Figure 22. Unipolar 2-Quadrant Multiplying Mode,  $V_{OUT} = 0\text{ to }+V_{REF}$

04452-005

## BIPOLAR MODE

### 4-Quadrant Multiplying Mode, $V_{OUT} = -V_{REF}$ to $+V_{REF}$

The AD5547/AD5557 contain on-chip all the 4-quadrant resistors necessary for precision bipolar multiplying operation. Such a feature minimizes the number of exponent components to only a voltage reference, dual op amp, and compensation capacitor (see Figure 23). For example, with a +10 V reference, the circuit yields a precision, bipolar -10 V to +10 V output.

$$V_{OUT} = (D/32768 - 1) \times V_{REF} \text{ (AD5547)} \quad (5)$$

$$V_{OUT} = (D/16384 - 1) \times V_{REF} \text{ (AD5557)} \quad (6)$$

Table 9 shows some of the results for the 16-bit AD5547.

**Table 9. AD5547 Output vs. Code**

D in Binary	$V_{OUT}$
1111 1111 1111 1111	$+V_{REF}$ (32,767/32,768)
1000 0000 0000 0001	$+V_{REF}$ (1/32,768)
1000 0000 0000 0000	0
0111 1111 1111 1111	$-V_{REF}$ (1/32,768)
0000 0000 0000 0000	$-V_{REF}$

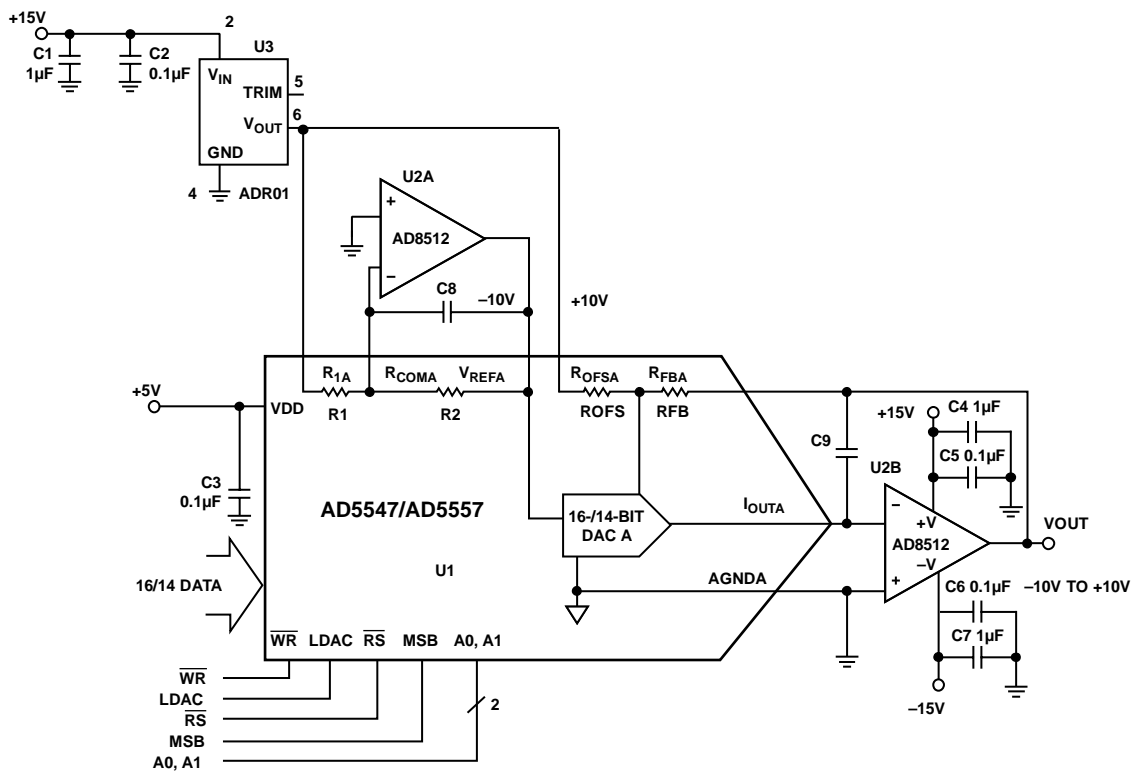

Figure 23. 4-Quadrant Multiplying Mode,  $V_{OUT} = -V_{REF}$  to  $+V_{REF}$

04482-006

**AC Reference Signal Attenuator**

Besides handling the digital waveform decoded from the parallel input data, the AD5547/AD5557 can also handle low frequency ac reference signals for signal attenuation, channel equalization, and waveform generation applications. The maximum signal range can be up to  $\pm 18$  V (see Figure 24).

**System Calibration**

The initial accuracy of the system can be adjusted by trimming the voltage reference ADR0x with a digital potentiometer (see Figure 25). The AD5170 provides a one-time programmable (OTP), 8-bit adjustment that is ideal and reliable for such calibration. Analog Devices, Inc., OTP digital potentiometer comes with programmable software that simplifies factory calibration.

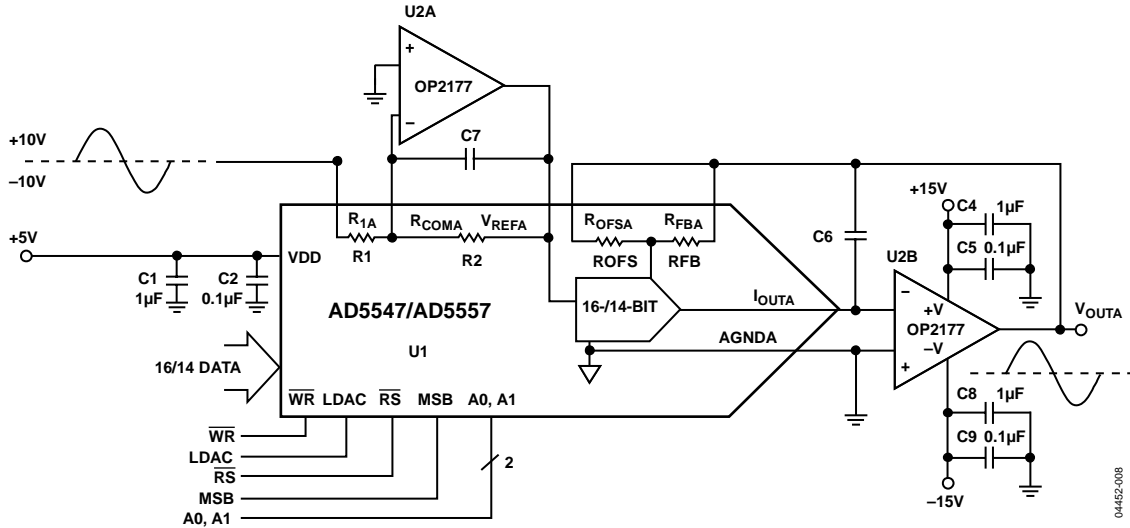

Figure 24. Signal Attenuator with AC Reference

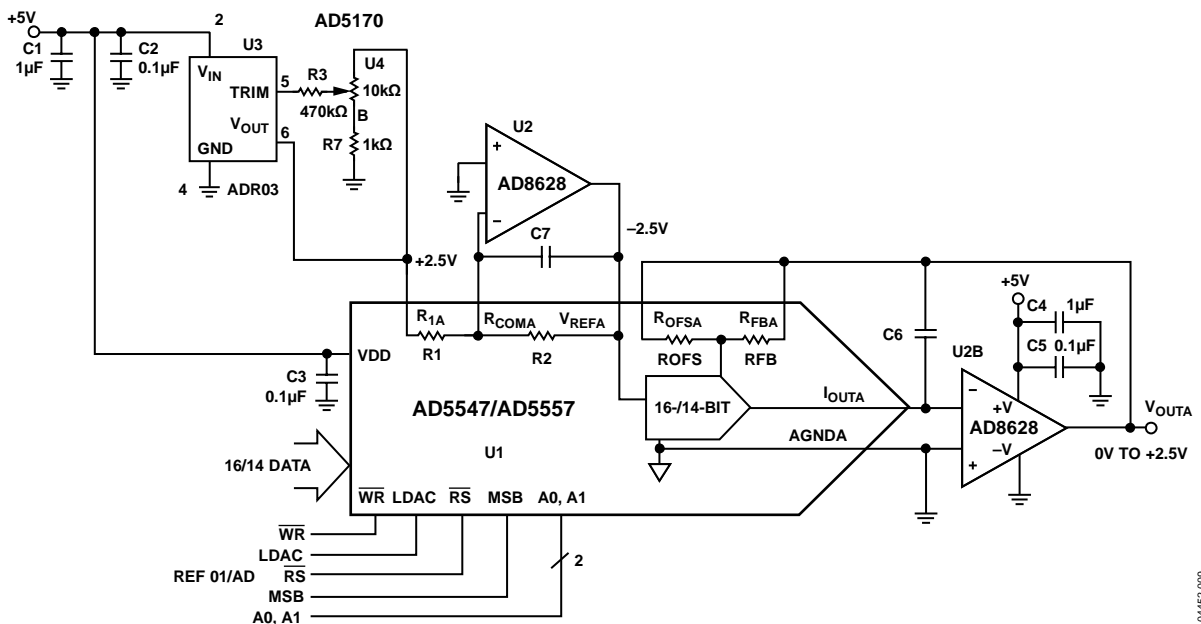

Figure 25. Full-Span Calibration

## REFERENCE SELECTION

When selecting a reference for use with the AD55xx series of current output DACs, pay attention to the output voltage, temperature coefficient specification of the reference. Choosing a precision reference with a low output temperature coefficient minimizes error sources. Table 10 lists some of the references available from Analog Devices, Inc., that are suitable for use with this range of current output DACs.

## AMPLIFIER SELECTION

The primary requirement for the current-steering mode is an amplifier with low input bias currents and low input offset voltage. Because of the code-dependent output resistance of the DAC, the input offset voltage of an op amp is multiplied by the variable gain of the circuit. A change in this noise gain between two adjacent digital fractions produces a step change in the output voltage due to the amplifier's input offset voltage. This output voltage change is superimposed upon the desired change in output between the two codes and gives rise to a differential linearity error, which, if large enough, can cause the DAC to be nonmonotonic.

The input bias current of an op amp also generates an offset at the voltage output because of the bias current flowing in the feedback resistor,  $R_{FB}$ .

Common-mode rejection of the op amp is important in voltage-switching circuits because it produces a code-dependent error at the voltage output of the circuit.

Provided that the DAC switches are driven from true wideband low impedance sources ( $V_{IN}$  and AGND), they settle quickly. Consequently, the slew rate and settling time of a voltage-switching DAC circuit is determined largely by the output op amp. To obtain minimum settling time in this configuration, minimize capacitance at the  $V_{REF}$  node (the voltage output node in this application) of the DAC. This is done by using low input capacitance buffer amplifiers and careful board design.

Analog Devices offers a wide range of amplifiers for both precision dc and ac applications, as listed in Table 11 and Table 12.

Table 10. Suitable Analog Devices Precision References

Part No.	Output Voltage (V)	Initial Tolerance (%)	Maximum Temperature Drift (ppm/°C)	$I_{SS}$ (mA)	Output Noise ( $\mu\text{V p-p}$ )	Package(s)
ADR01	10	0.05	3	1	20	SOIC-8
ADR01	10	0.05	9	1	20	TSOT-5, SC70-5
ADR02	5.0	0.06	3	1	10	SOIC-8
ADR02	5.0	0.06	9	1	10	TSOT-5, SC70-5
ADR03	2.5	0.1	3	1	6	SOIC-8
ADR03	2.5	0.1	9	1	6	TSOT-5, SC70-5
ADR06	3.0	0.1	3	1	10	SOIC-8
ADR06	3.0	0.1	9	1	10	TSOT-5, SC70-5
ADR420	2.048	0.05	3	0.5	1.75	SOIC-8, MSOP-8
ADR421	2.50	0.04	3	0.5	1.75	SOIC-8, MSOP-8
ADR423	3.00	0.04	3	0.5	2	SOIC-8, MSOP-8
ADR425	5.00	0.04	3	0.5	3.4	SOIC-8, MSOP-8
ADR431	2.500	0.04	3	0.8	3.5	SOIC-8, MSOP-8
ADR435	5.000	0.04	3	0.8	8	SOIC-8, MSOP-8
ADR391	2.5	0.16	9	0.12	5	TSOT-5
ADR395	5.0	0.10	9	0.12	8	TSOT-5

Table 11. Suitable Analog Devices Precision Op Amps

Part No.	Supply Voltage (V)	$V_{OS}$ Maximum ( $\mu\text{V}$ )	$I_B$ Maximum (nA)	0.1 Hz to 10 Hz Noise ( $\mu\text{V p-p}$ )	Supply Current ( $\mu\text{A}$ )	Package(s)
OP97	$\pm 2$ to $\pm 20$	25	0.1	0.5	600	SOIC-8, PDIP-8
OP1177	$\pm 2.5$ to $\pm 15$	60	2	0.4	500	MSOP-8, SOIC-8
AD8675	$\pm 5$ to $\pm 18$	75	2	0.1	2300	MSOP-8, SOIC-8
AD8671	$\pm 5$ to $\pm 15$	75	12	0.077	3000	MSOP-8, SOIC-8
ADA4004-1	$\pm 5$ to $\pm 15$	125	90	0.1	2000	SOIC-8, SOT-23-5
AD8603	1.8 to 5	50	0.001	2.3	40	TSOT-5
AD8607	1.8 to 5	50	0.001	2.3	40	MSOP-8, SOIC-8
AD8605	2.7 to 5	65	0.001	2.3	1000	WLCSP-5, SOT-23-5
AD8615	2.7 to 5	65	0.001	2.4	2000	TSOT-5
AD8616	2.7 to 5	65	0.001	2.4	2000	MSOP-8, SOIC-8

Table 12. Suitable Analog Devices High Speed Op Amps

Part No.	Supply Voltage (V)	BW @ ACL (MHz)	Slew Rate (V/μs)	V <sub>OS</sub> (Max) (μV)	I <sub>B</sub> (Max) (nA)	Package(s)
AD8065	5 to 24	145	180	1500	0.006	SOIC-8, SOT-23-5
AD8066	5 to 24	145	180	1500	0.006	SOIC-8, MSOP-8
AD8021	5 to 24	490	120	1000	10,500	SOIC-8, MSOP-8
AD8038	3 to 12	350	425	3000	750	SOIC-8, SC70-5
ADA4899	5 to 12	600	310	35	100	LFCSP-8, SOIC-8
AD8057	3 to 12	325	1000	5000	500	SOT-23-5, SOIC-8
AD8058	3 to 12	325	850	5000	500	SOIC-8, MSOP-8
AD8061	2.7 to 8	320	650	6000	350	SOT-23-5, SOIC-8
AD8062	2.7 to 8	320	650	6000	350	SOIC-8, MSOP-8
AD9631	±3 to ±6	320	1300	10,000	7000	SOIC-8, PDIP-8

Table 13 lists the latest DACs available from Analog Devices.

Table 13. ADI Current Output DACs

Model	Bits	Outputs	Interface	Package	Comments
AD5425	8	1	SPI, 8-Bit Load	MSOP-10	Fast 8-bit load; see also <a href="#">AD5426</a>
AD5426	8	1	SPI	MSOP-10	See also <a href="#">AD5425</a> fast load
AD5450	8	1	SPI	TSOT-8	See also <a href="#">AD5425</a> fast load
AD5424	8	1	Parallel	TSSOP-16	
AD5429	8	2	SPI	TSSOP-16	
AD5428	8	2	Parallel	TSSOP-20	
AD5432	10	1	SPI	MSOP-10	
AD5451	10	1	SPI	TSOT-8	
AD5433	10	1	Parallel	TSSOP-20	
AD5439	10	2	SPI	TSSOP-16	
AD5440	10	2	Parallel	TSSOP-24	
AD5443	12	1	SPI	MSOP-10	See also <a href="#">AD5452</a> and <a href="#">AD5444</a>
AD5452	12	1	SPI	TSOT-8	Higher accuracy version of <a href="#">AD5443</a> ; see also <a href="#">AD5444</a>
AD5445	12	1	Parallel	TSSOP-20	
AD5444	12	1	SPI	MSOP-10	Higher accuracy version of <a href="#">AD5443</a> ; see also <a href="#">AD5452</a>
AD5449	12	2	SPI	TSSOP-16	
AD5415	12	2	SPI	TSSOP-24	Uncommitted resistors
AD5447	12	2	Parallel	TSSOP-24	
AD5405	12	2	Parallel	LFCSP-40	Uncommitted resistors
AD5453	14	1	SPI	TSOT-8	
AD5553	14	1	SPI	MSOP-8	
AD5556	14	1	Parallel	TSSOP-28	
AD5446	14	1	SPI	MSOP-10	MSOP version of <a href="#">AD5453</a> ; compatible with <a href="#">AD5443</a> , <a href="#">AD5432</a> , and <a href="#">AD5426</a>
AD5555	14	2	SPI	TSSOP-16	
AD5557	14	2	Parallel	TSSOP-38	
AD5543	16	1	SPI	MSOP-8	
AD5546	16	1	Parallel	TSSOP-28	
AD5545	16	2	SPI	TSSOP-16	
AD5547	16	2	Parallel	TSSOP-38	

OUTLINE DIMENSIONS

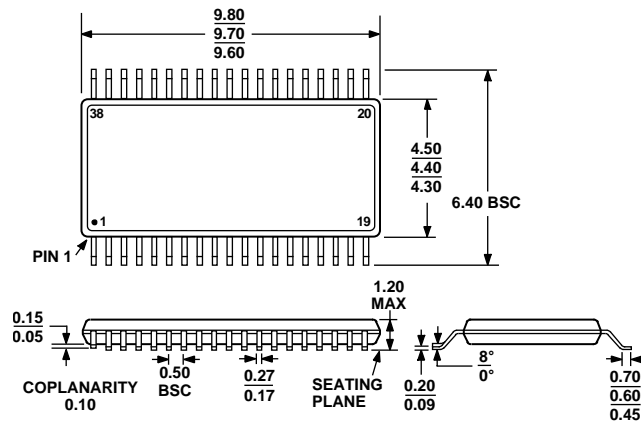

COMPLIANT TO JEDEC STANDARDS MO-153-BD-1

Figure 26. 38-Lead Thin Shrink Small Outline Package [TSSOP] (RU-38)

Dimensions shown in millimeters

ORDERING GUIDE

Model <sup>1</sup>	Resolution (Bits)	DNL (LSB)	INL (LSB)	Temperature Range	Package Description	Package Option	Ordering Quantity
AD5547BRU	16	±1	±2	-40°C to +125°C	38-Lead TSSOP	RU-38	50
AD5547BRU-REEL7	16	±1	±2	-40°C to +125°C	38-Lead TSSOP	RU-38	1,000
AD5547BRUZ	16	±1	±2	-40°C to +125°C	38-Lead TSSOP	RU-38	50
AD5547CRUZ	16	±1	±1	-40°C to +125°C	38-Lead TSSOP	RU-38	50
AD5547CRUZ-REEL7	16	±1	±1	-40°C to +125°C	38-Lead TSSOP	RU-38	1,000
AD5557CRU	14	±1	±1	-40°C to +125°C	38-Lead TSSOP	RU-38	50
AD5557CRU-REEL7	14	±1	±1	-40°C to +125°C	38-Lead TSSOP	RU-38	1,000
AD5557CRUZ	14	±1	±1	-40°C to +125°C	38-Lead TSSOP	RU-38	50

<sup>1</sup> Z = RoHS Compliant Part.